

8

7

6

5

4

3

2

1

REVISIONS		
REV	DESCRIPTION	DATE
A	SEE ECN# D972105-A FOR CHANGE LIST	05/04/98
B	SEE ECN# D972105-B FOR CHANGE LIST	04/23/99

D

D

C

C

B

B

A

A

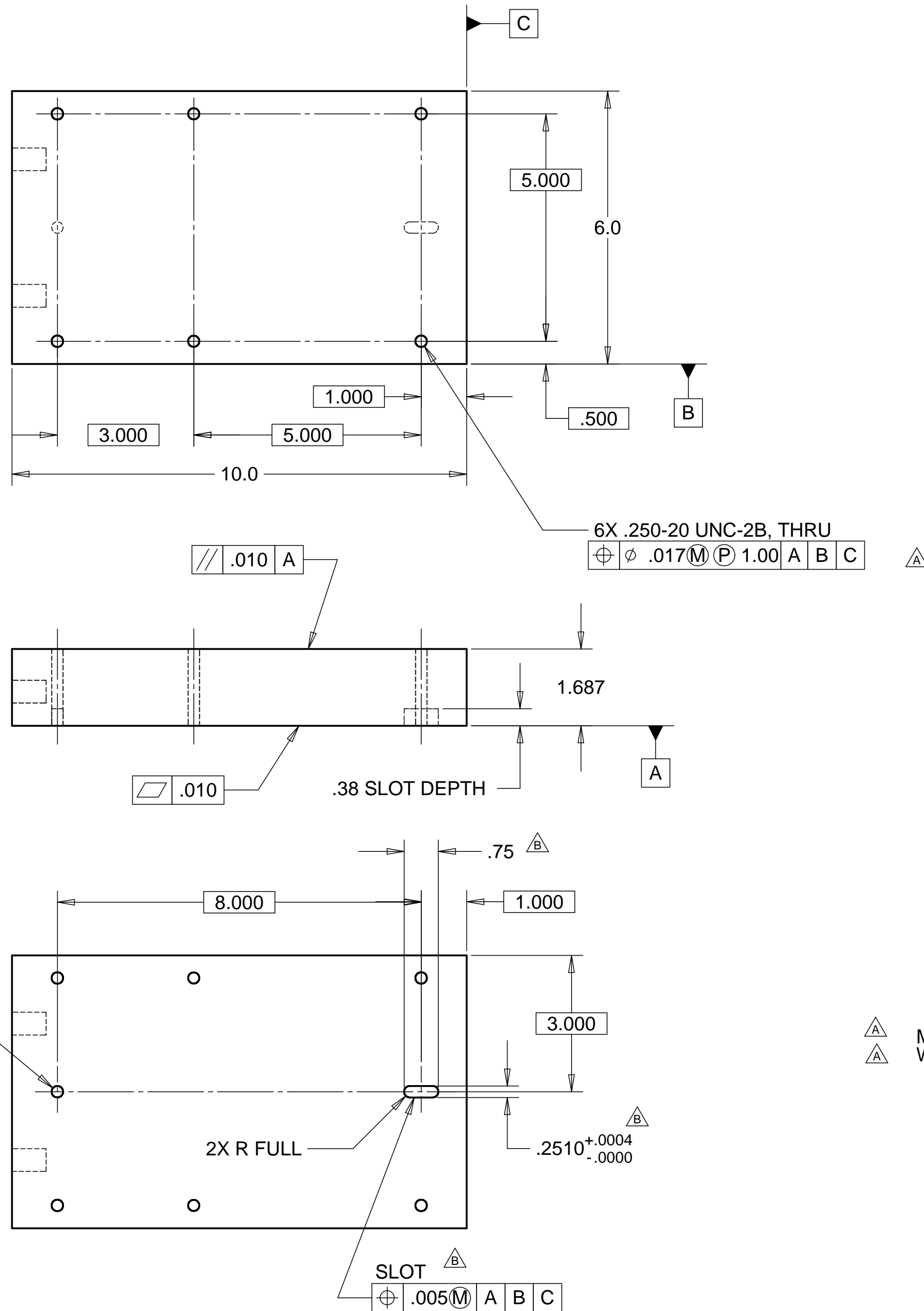
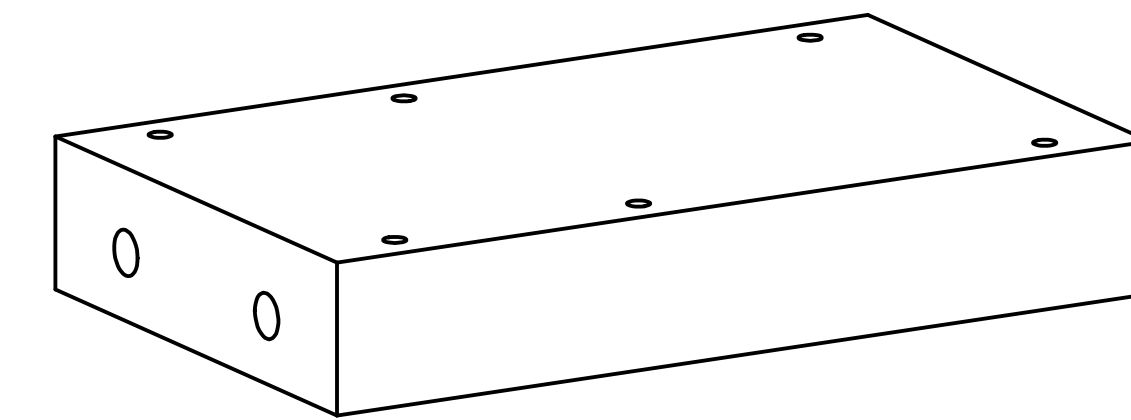

NOTES: UNLESS OTHERWISE SPECIFIED

- ALL DIMENSIONS IN INCHES
- DIMENSIONS AND TOLERANCING PER ANASI Y14.5M-1994
- SURFACE TEXTURE PER ANI/ASME B 46.1-1985
- REMOVE ALL BURRS AND BREAK SHARP EDGES TO A MAXIMUM OF .015
- ALL INSIDE CORNERS TO BE .015 RADIUS MAX
- COUNTERSINK 82 DEGREES ALL TAPPED HOLES TO MAJOR DIAMETER
- COUNTERSINK 82 DEGREES APPROXIMATELY .03/.06 DEEP ALL DRILLED HOLES
- PARTS TO BE THOROUGHLY CLEANED TO REMOVE ALL OIL, GREASE, DIRT AND CHIPS
- PART NUMBER (DRAWING NO. PLUS DASH NO. PLUS SERIAL NO.) TO BE CLEARLY MARKED ON THE PART ITSELF.

PARTS LIST

UNLESS OTHERWISE SPECIFIED: DIMENSIONS ARE IN INCHES -TOLERANCES-		CAD GENERATED DRAWING, DO NOT MANUALLY UPDATE DO NOT SCALE DRAWING		HYTEC, INC	
DECIMALS X = +/- .1 XX = +/- .03 XXX = +/- .010		ANGULAR = +/- .30° SURFACE FINISH = 250		TITLE LIGO COARSE X-Y TRANSLATION SPACER BLOCK	
FINISH		SIGNATURE	DATE	DWG. NO.	SHEET NO.
		ROGER L. SMITH	8/22/97	D972105	D 1 of 1
PART NO.		CHECKED	DATE		
D972105-1		HARRY SALAZAR	8/25/97		
		ENGR.	DATE		
		T. THOMPSON	8/25/97		
		APPROVED	DATE	SCALE	REVISION
		T. THOMPSON	8/25/97	1/2	B

8

7

6

5

4

3

2

1