

8 7 6 5 4 3 2 1

REVISIONS			
REV.	DESCRIPTION	DATE	APPROVED

D

D

C

C

B

B

A

A

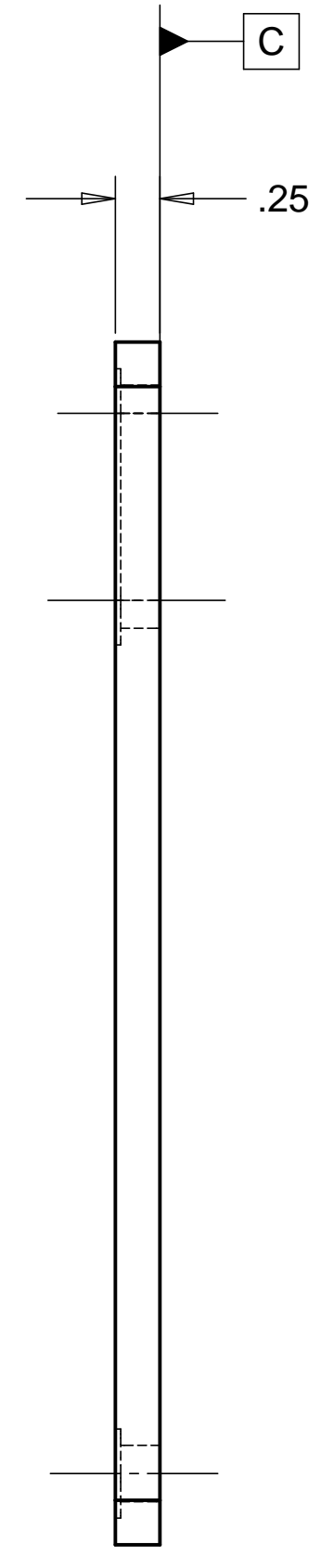
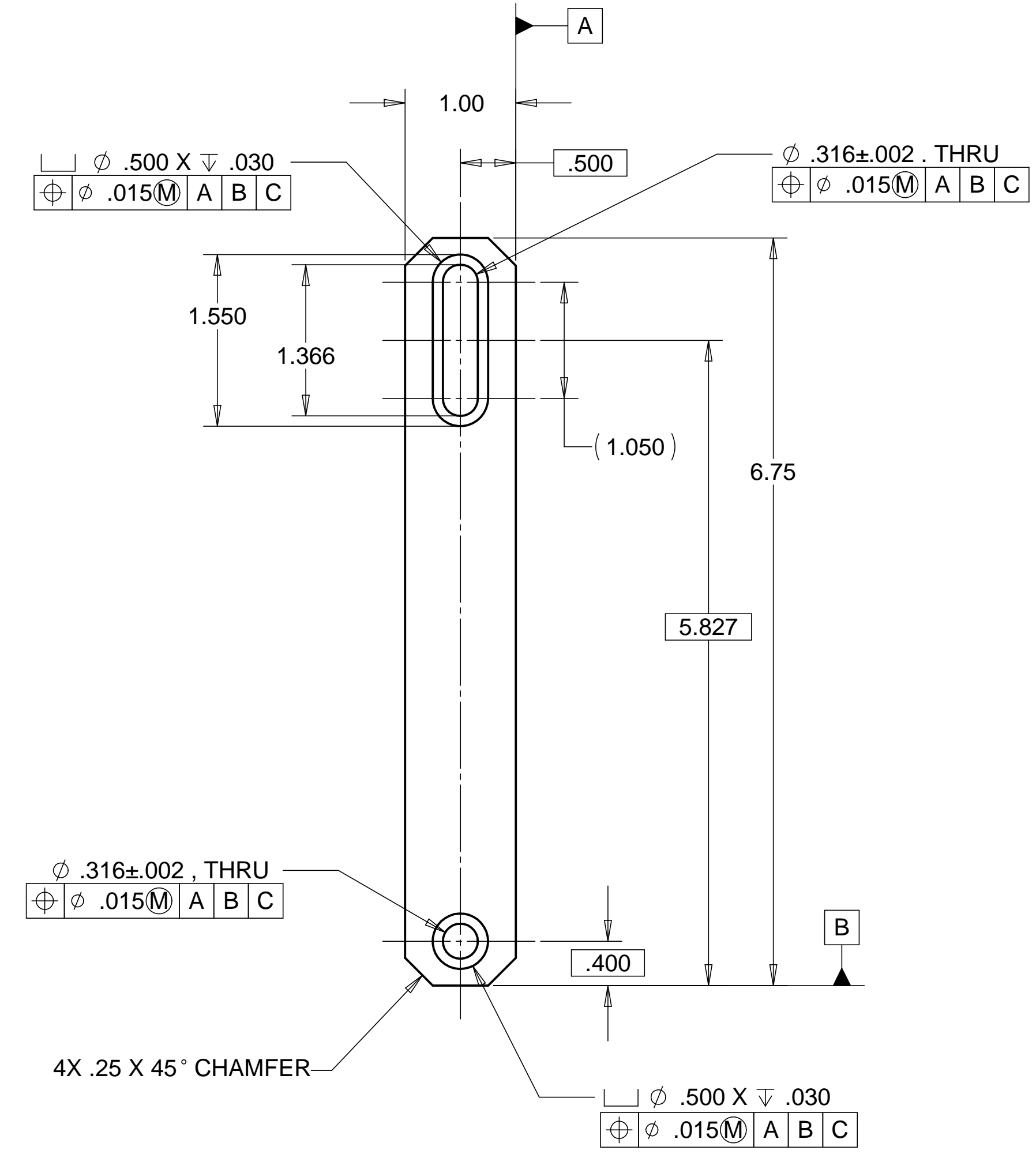

MATL: 303 SST
WEIGHT: 0.44 lbs.

NOTES: UNLESS OTHER WISE SPECIFIED

1. ALL DIMENSIONS IN INCHES
2. DIMENSIONS AND TOLERANCING PER ANAS1 Y14.5M-1994
3. SURFACE TEXTURE PER ANI/ASME B 46.1-1985
4. REMOVE ALL BURRS AND BREAK SHARP EDGES TO A MAXIMUM OF .015
5. ALL INSIDE CORNERS TO BE .015 RADIUS MAX
6. COUNTERSINK 82 DEGREES ALL TAPPED HOLES TO MAJOR DIAMETER
7. COUNTERSINK 82 DEGREES APPROXIMATELY .015 DEEP ALL DRILLED HOLES
8. PARTS TO BE THOROUGHLY CLEANED TO REMOVE ALL OIL, GREASE, DIRT AND CHIPS
9. PART NUMBER (DRAWING NO. PLUS DASH NO. PLUS SERIAL NO.) TO BE CLEARLY MARKED ON THE PART ITSELF.

PARTS LIST			
UNLESS OTHERWISE SPECIFIED: DIMENSIONS ARE IN INCHES -TOLERANCES- DECIMALS ANGULAR = +/- 30' .X = +/- .1 .XX = +/- .03 .XXX = +/- .010 SURFACE FINISH = 250	CAD GENERATED DRAWING, DO NOT MANUALLY UPDATE DO NOT SCALE DRAWING		HYTEC, INC TITLE LIGO SCISSOR TABLE STOP LINK
	FINISH	SIGNATURE DESIGNED ROGER L. SMITH DRAWN ROGER L. SMITH CHECKED ERIK SWENSEN ENGR. ERIK SWENSEN APPROVED T. THOMPSON	DATE 03-24-98 03-25-98 03-25-98 03-25-98
PART NO. D972127-1	SCALE 1/1	REVISION	REVISION

8 7 6 5 4 3 2 1