

REV.	DESCRIPTION	DATE	APPROVED
A	SEE ECN# D972212-A FOR CHANGE LIST	11-03-97	T. THOMPSON
B	SEE ECN# D972212-B FOR CHANGE LIST	03-11-98	T. THOMPSON
C	SEE ECN# D972212-C FOR CHANGE LIST	03-24-98	T. THOMPSON

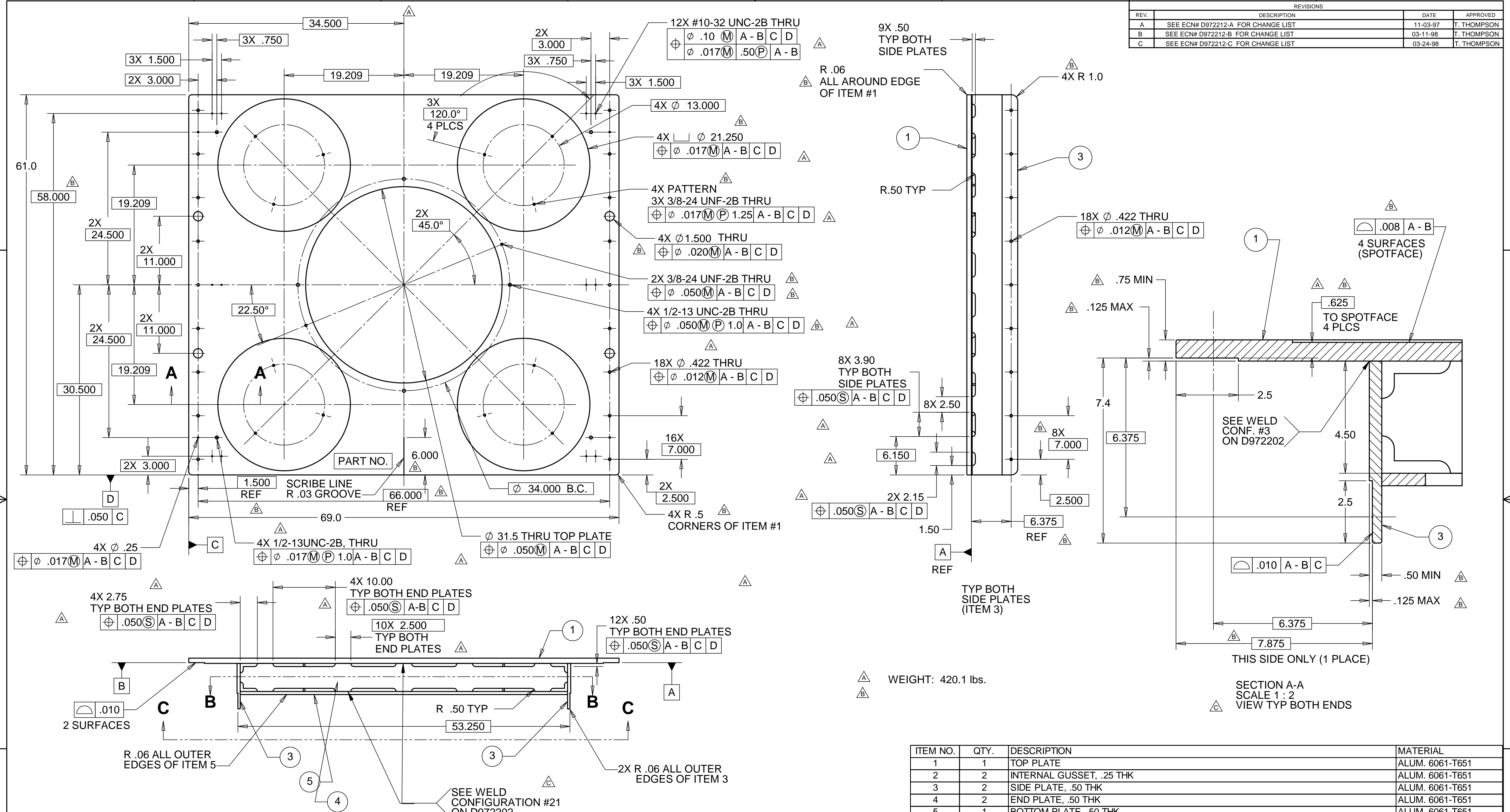

SECTION A-A
SCALE 1 : 2
VIEW TYP BOTH ENDS

NOTES: UNLESS OTHERWISE SPECIFIED

- ALL DIMENSIONS IN INCHES
- DIMENSIONS AND TOLERANCING PER ASME Y14.5M-1994
- SURFACE TEXTURE PER ANSI/ASME B 46.1-1985
- REMOVE ALL BURRS AND BREAK SHARP EDGES TO A MAXIMUM OF .015
- ALL INSIDE CORNERS TO BE .015 RADIUS MAX
- COUNTERSINK 82 DEGREES ALL TAPPED HOLES TO MAJOR DIAMETER
- COUNTERSINK 82 DEGREES APPROXIMATELY .015 DEEP ALL DRILLED HOLES
- PART NUMBER (DRAWING NO. PLUS DASH NO. PLUS SERIAL NO.) TO BE CLEARLY MARKED ON THE PART ITSELF.
- ALL FABRICATION, CLEANING, AND HANDLING MAINTAINED TO HYTEC SPECIFICATION LIGO-TS-03 CATEGORY 1.
- ALL ALUM. WELDING DONE BY A GTAW PROCESS USING 2% THORIATED TUNGSTEN WELDING ELECTRODES AND ER4043 WELDING ROD (SPEC. PER AWS A5.10-80).
- NO SULFER BASED CUTTING FLUIDS ALLOWED. APPROVED MACHINE LUBRICANT: HANSTERFER S-500CF.
- DIMENSIONS FOR GUSSET WELD PREP TABS & SLOTS TO BE INTERPRETED PRIOR TO WELDING.

ITEM NO.	QTY.	DESCRIPTION	MATERIAL
1	1	TOP PLATE	ALUM. 6061-T651
2	2	INTERNAL GUSSET, .25 THK	ALUM. 6061-T651
3	2	SIDE PLATE, .50 THK	ALUM. 6061-T651
4	2	END PLATE, .50 THK	ALUM. 6061-T651
5	1	BOTTOM PLATE, .50 THK	ALUM. 6061-T651
6	2	INTERNAL GUSSET, .25 THK	ALUM. 6061-T651
7	4	INTERNAL GUSSET, .25 THK	ALUM. 6061-T651

PARTS LIST			HYTEC, INC	
UNLESS OTHERWISE SPECIFIED: DIMENSIONS ARE IN INCHES -TOLERANCES-			LIGO BSC SUPPORT TABLE WELDMENT	
CAD GENERATED DRAWING. DO NOT MANUALLY UPDATE DO NOT SCALE DRAWING			TITLE	
DECIMALS: X = +/- .1, XX = +/- .03, XXX = +/- .010			DWG. NO. D972212	
ANGULAR = +/- .30'			SIZE D	
SURFACE FINISH = 250			SHEET NO. 1 of 3	
FINISH: ALL MACHINED SURFACES 64 RMS			REVISION C	
PART NO. D972212-1			SCALE 1/8	
SIGNATURE: ROGER L. SMITH			DATE: 5-28-97	
DRAWN: ROGER L. SMITH			DATE: 5-28-97	
CHECKED: HARRY SALAZAR			DATE: 6-6-97	
ENGR.: T. THOMPSON			DATE: 7-10-97	
APPROVED: T. THOMPSON			DATE: 7-10-97	

8 7 6 5 4 3 2 1

REV.	DESCRIPTION	DATE	APPROVED
A	SEE ECN# D972212-A FOR CHANGE LIST	11-03-97	T. THOMPSON
B	SEE ECN# D972212-B FOR CHANGE LIST	03-11-98	T. THOMPSON
C	SEE ECN# D972212-C FOR CHANGE LIST	03-24-98	T. THOMPSON

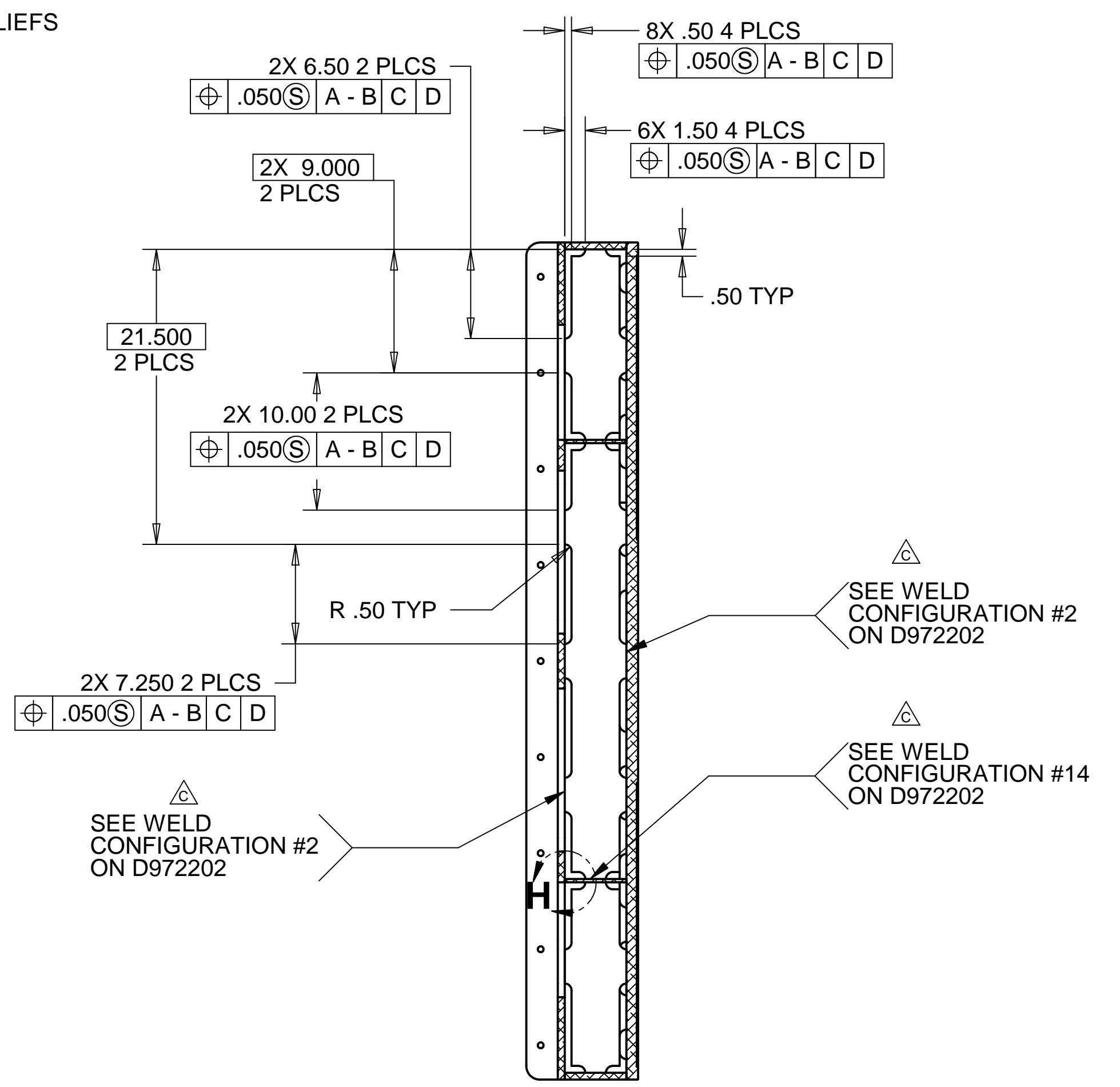
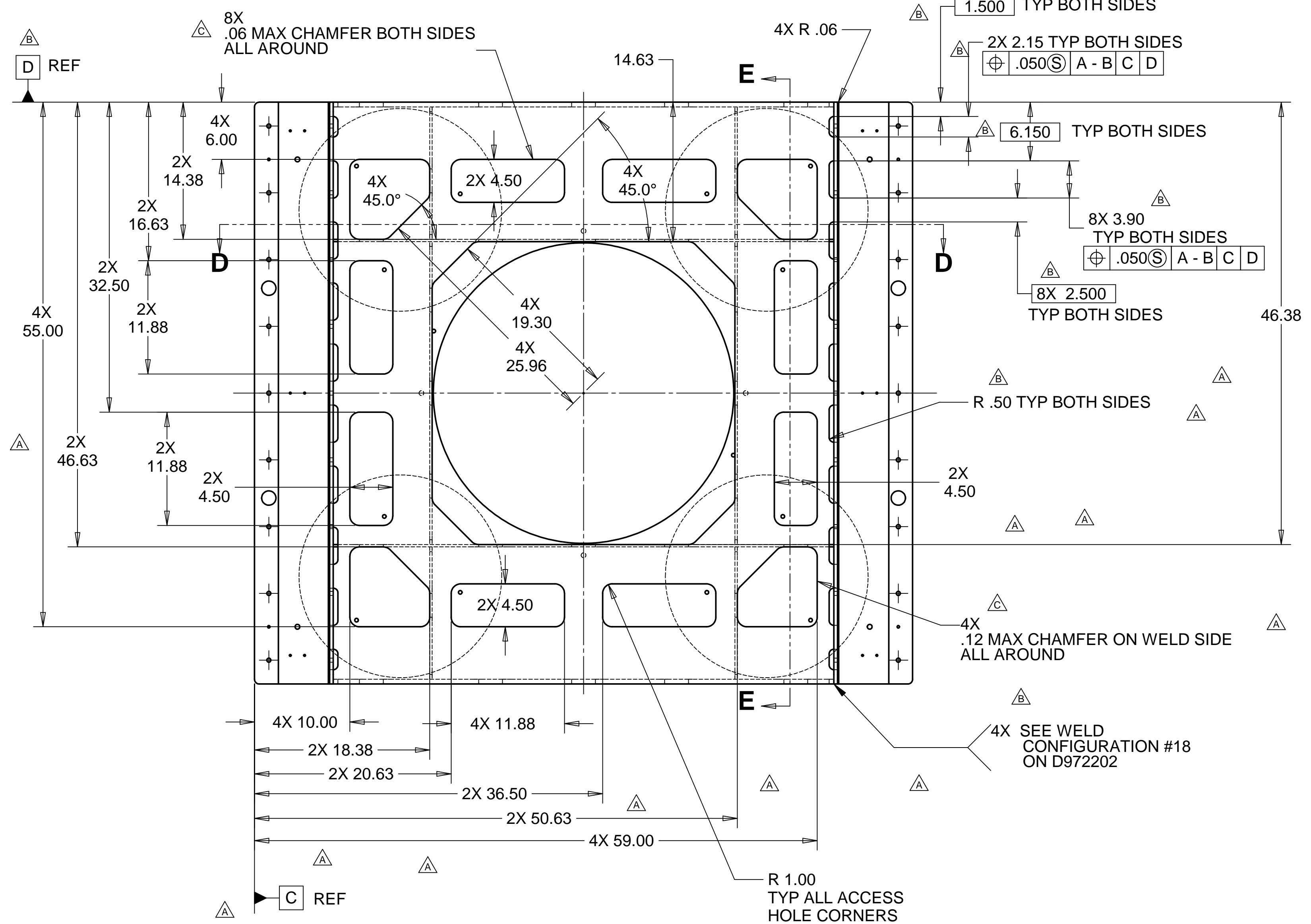
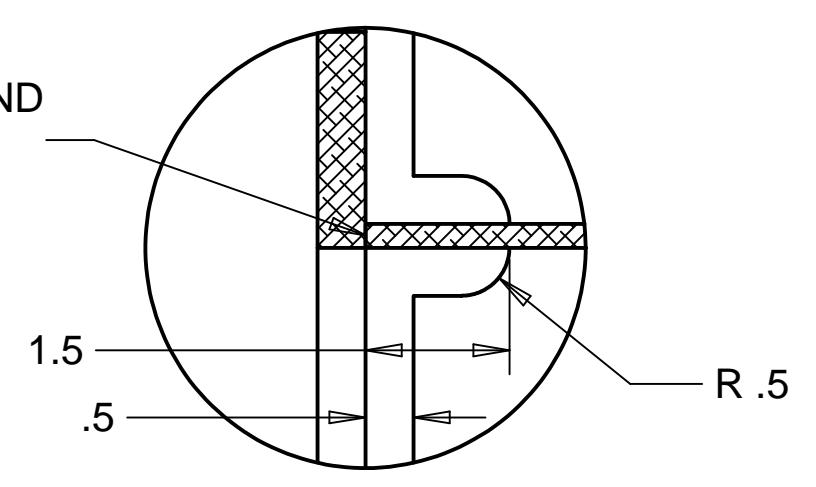
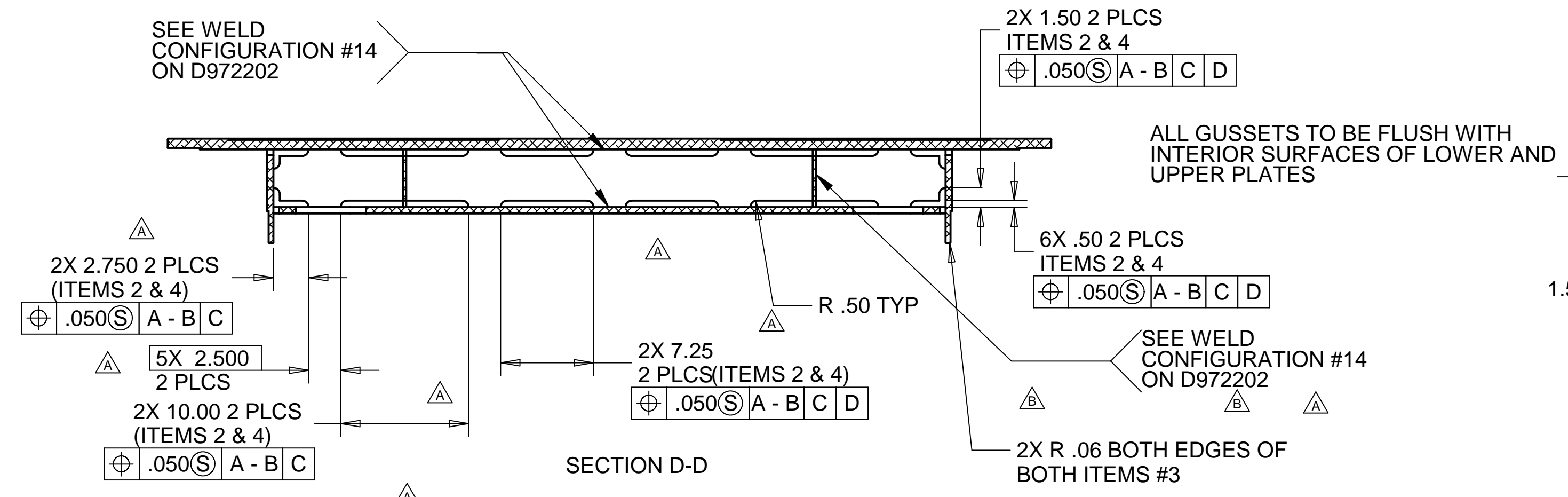

PARTS LIST			
UNLESS OTHERWISE SPECIFIED: DIMENSIONS ARE IN INCHES -TOLERANCES-		CAD GENERATED DRAWING. DO NOT MANUALLY UPDATE DO NOT SCALE DRAWING	
DECIMALS .X = +/- .1 .XX = +/- .03 .XXX = +/- .010	ANGULAR = +/- .30' SURFACE FINISH = 250	TITLE HYTEC, INC LIGO BSC SUPPORT TABLE WELDMENT	
FINISH ALL MACHINED SURFACES 64 RMS	PART NO. D972212-1	SIGNATURE ROGER L. SMITH ROGER L. SMITH HARRY SALAZAR T. THOMPSON T. THOMPSON	DATE 5-28-97 5-28-97 6-6-97 7-10-97 7-10-97
DWG. NO. D972212		SCALE 1/8	SIZE SHEET NO. D 2 of 3 REVISION C

8 7 6 5 4 3 2 1

8 7 6 5 4 3 2 1

REVISIONS			
REV.	DESCRIPTION	DATE	APPROVED
B	SEE ECN# D972212-B FOR CHANGE LIST	03-11-98	T. THOMPSON
C	SEE ECN# D972212-C FOR CHANGE LIST	03-24-98	T. THOMPSON

D
C
B
A

D
C
B
A

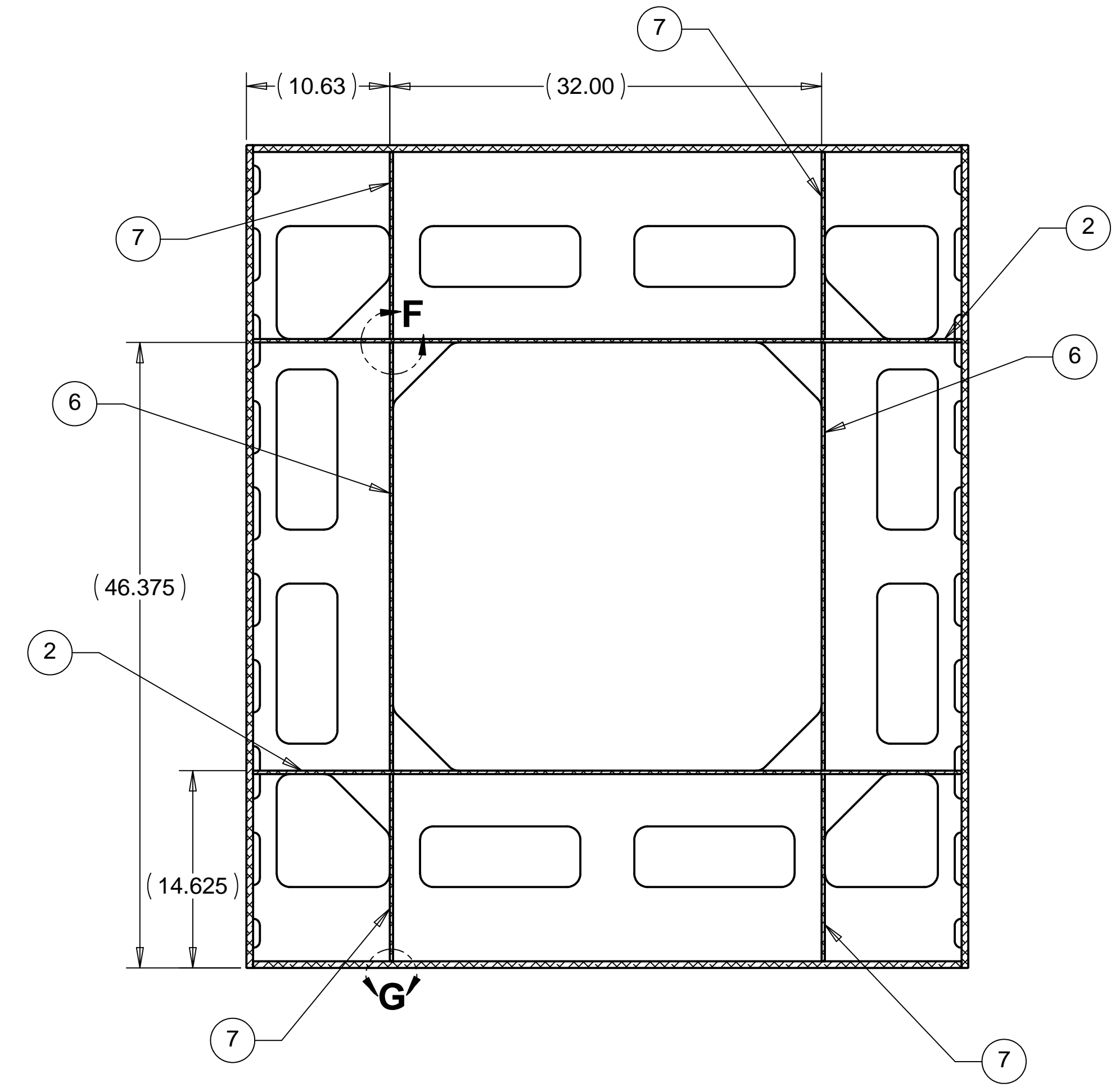

SECTION B-B
FROM SHEET D1

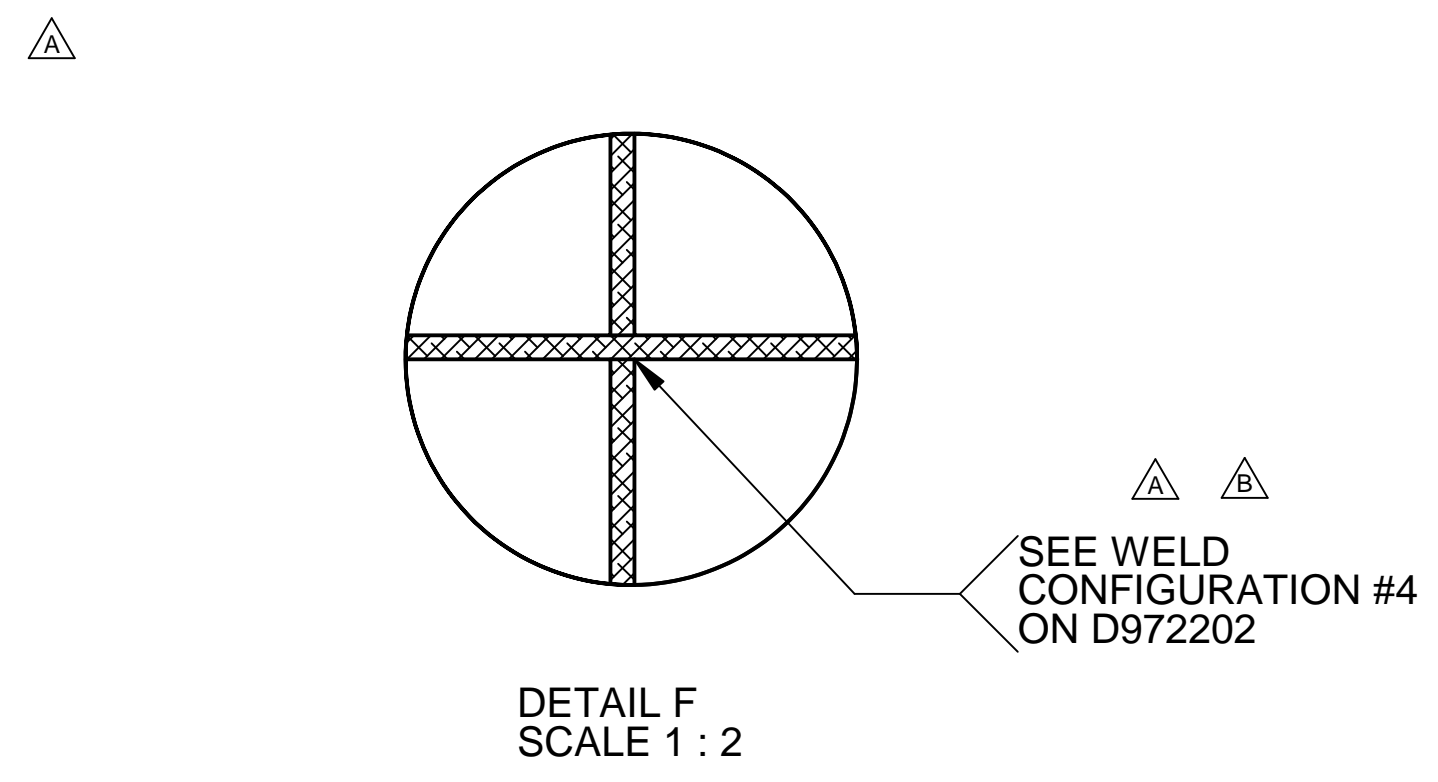

DETAIL F
SCALE 1 : 2

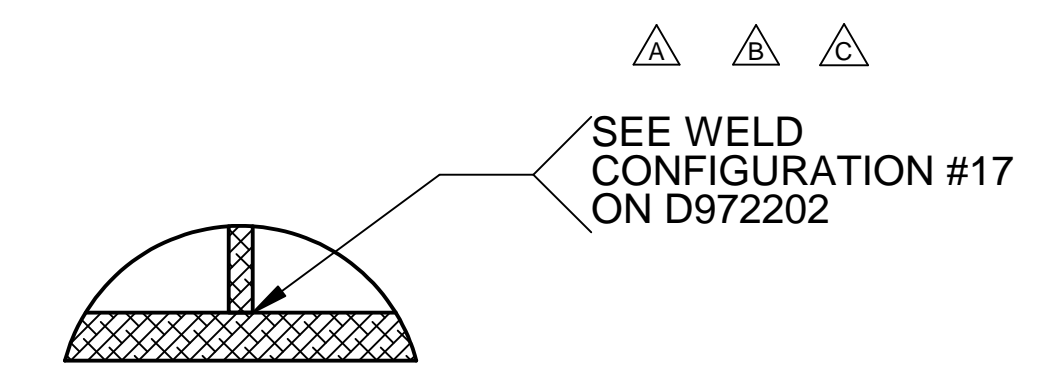

DETAIL G
SCALE 1 : 2

PARTS LIST			
UNLESS OTHERWISE SPECIFIED: DIMENSIONS ARE IN INCHES -TOLERANCES- DECIMALS ANGULAR = +/- .30' .X = +/- .1 .XX = +/- .03 .XXX = +/- .010 SURFACE FINISH = 250	CAD GENERATED DRAWING. DO NOT MANUALLY UPDATE DO NOT SCALE DRAWING		HYTEC, INC TITLE LIGO BSC SUPPORT TABLE WELDMENT
	FINISH ALL MACHINED SURFACES 64 RMS	DESIGNED ROGER L. SMITH 10-22-97 DRAWN ROGER L. SMITH 15-20-97 CHECKED HARRY SALAZAR 03-06-98 ENGR. T. THOMPSON 03-11-98 APPROVED T. THOMPSON 03-11-98	
PART NO. D972212-1			

8 7 6 5 4 3 2 1