

8 7 6 5 4 3 2 1

REVISIONS			
REV.	DESCRIPTION	DATE	APPROVED

D

D

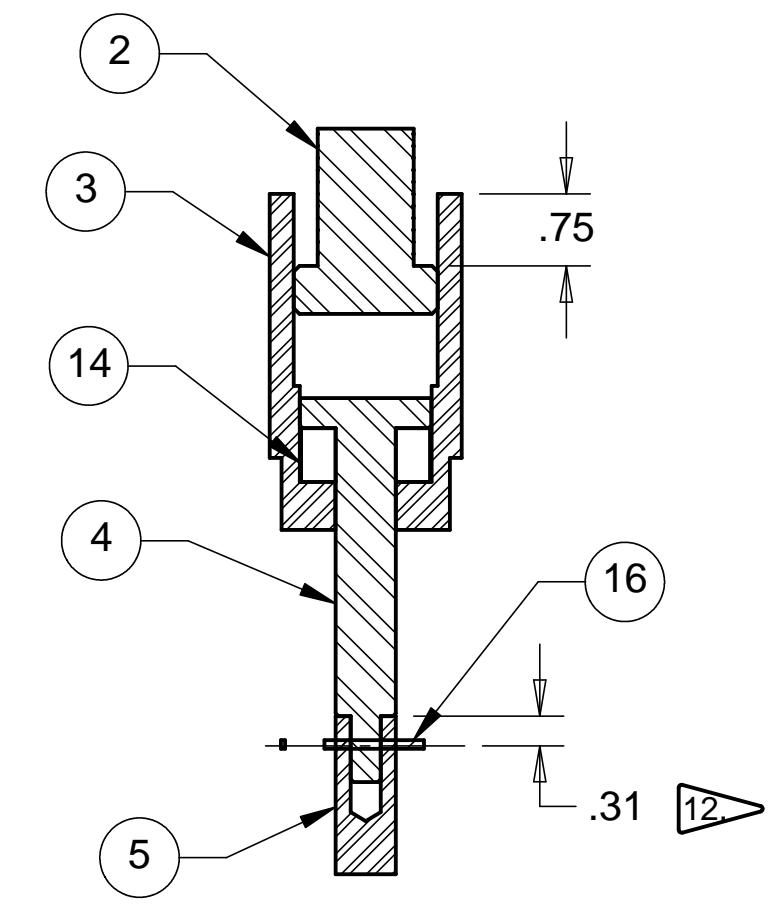
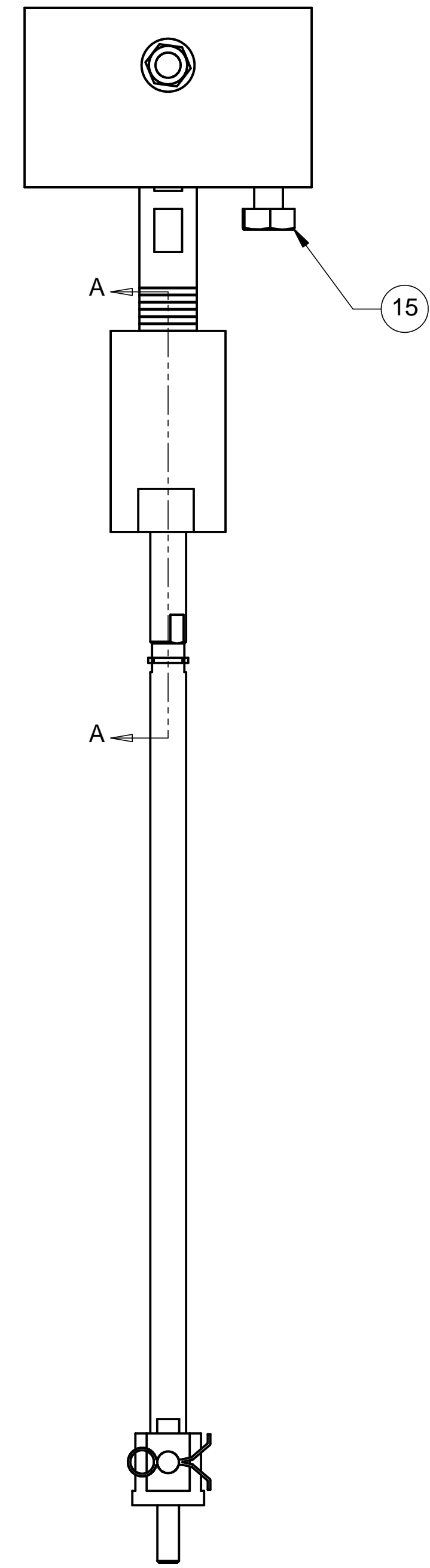
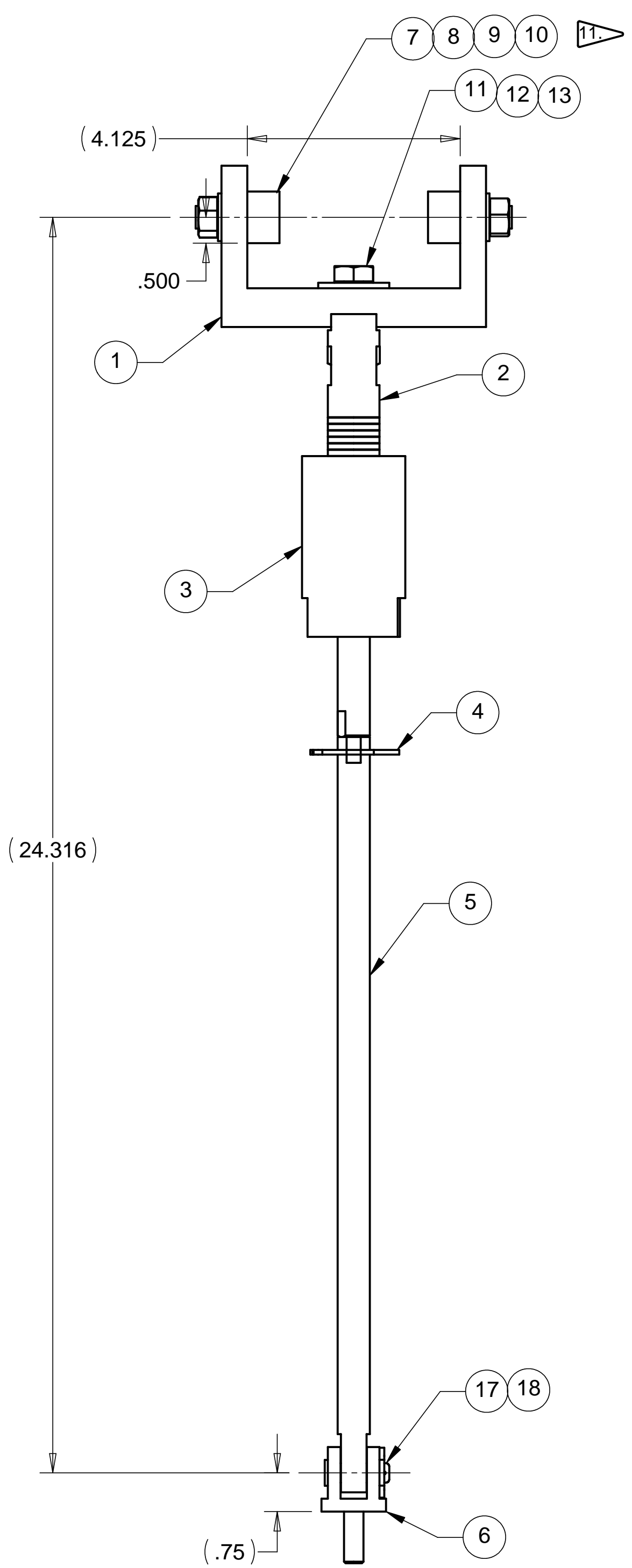

SECTION A-A

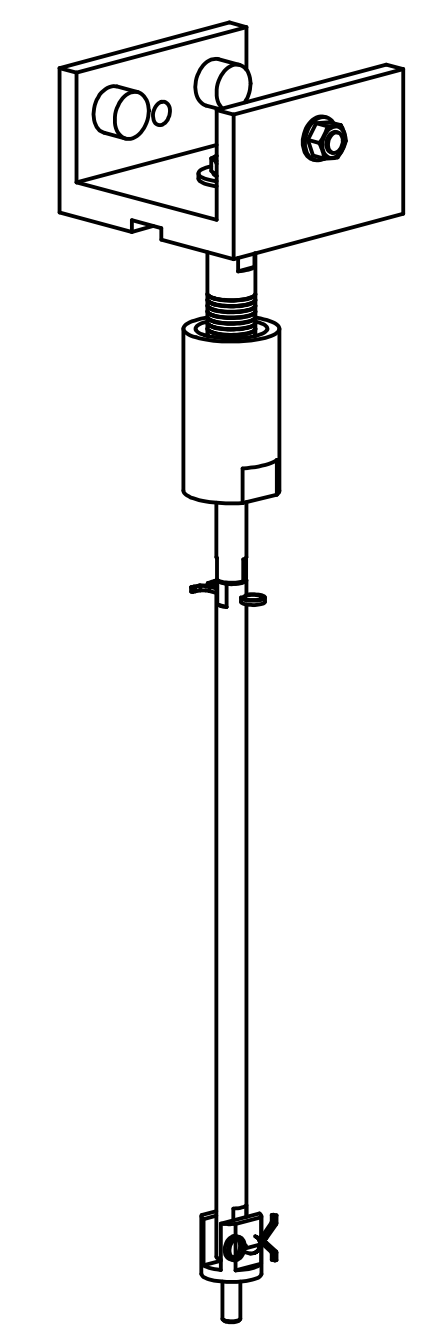

C

C

B

B

A

A

NOTES: UNLESS OTHERWISE SPECIFIED

1. ALL DIMENSIONS IN INCHES
2. DIMENSIONS AND TOLERANCING PER ASME Y14.5M-1994
3. SURFACE TEXTURE PER ANSI/ASME B 46.1-1985
4. REMOVE ALL BURRS AND BREAK SHARP EDGES TO A MAXIMUM OF .015
5. ALL INSIDE CORNERS TO BE .015 RADIUS MAX
6. COUNTERSINK 82 DEGREES ALL TAPPED HOLES TO MAJOR DIAMETER
7. COUNTERSINK 82 DEGREES APPROXIMATELY .015 DEEP ALL DRILLED HOLES
8. PARTS TO BE THOROUGHLY CLEANED TO REMOVE ALL OIL, GREASE, DIRT AND CHIPS
9. PART NUMBER (DRAWING NO. PLUS DASH NO. PLUS SERIAL NO.) TO BE CLEARLY MARKED ON THE PART ITSELF.
10. PART WEIGHS 49.3 Lbs.

- 11 USE A VAPOR DEGREASER TO REMOVE ALL GREASE FROM CAM FOLLOWERS (ITEM 7).
- 12 DRILL AND COTTER PIN AFTER BOLTING CONNECTION TOGETHER.
- 13 STAMP ALL MATING PIECES.

ITEM NO.	QTY.	PART NO.	DESCRIPTION
1	1	D972946-1	RAIL SYSTEM TROLLEY
2	1	D972949-1	RAIL SYSTEM TROLLEY LINK #1
3	1	D972950-1	RAIL SYSTEM TROLLEY LINK #2
4	1	D972951-1	RAIL SYSTEM TROLLEY LINK #3
5	1	D972432-1	BSC RAIL SYSTEM TROLLEY LINK #2
6	1	D972953-1	RAIL SYSTEM TROLLEY LINK #5
7	3	RBC-S-32-LW	CAM FOLLOWER, 1.0 O.D. X .625, MOORE BEARING
8	3	STD HARDWARE	WASHER, SST 7/16 FLAT
9	3	STD HARDWARE	WASHER, SST 7/16 LOCK
10	3	STD HARDWARE	SST HEX NUT, 7/16-20 UNC-2B
11	1	STD HARDWARE	WASHER, SST 1/2 FLAT
12	1	STD HARDWARE	WASHER, SST 1/2 LOCK
13	1	STD HARDWARE	HEX HEAD SST BOLT, 1/2-13 UNC-2A X 1.0 LONG
14	1	McMASTER 60715K12	THRUST BEARING, 1 11/32 O.D. X .562 THK
15	1	STD HARDWARE	HEX HEAD SST BOLT, 1/2-13 UNC-2A X 1.5 LONG
16	1	McMASTER 98355A030	COTTER PIN, 1/16" X 1.0 LONG
17	1	McMASTER 92390A216	CLEVIS PIN, 5/16 DIA. X 1.25 LONG
18	1	McMASTER 98355A130	COTTER PIN, 1/8" X .75 LONG

PARTS LIST

UNLESS OTHERWISE SPECIFIED: DIMENSIONS ARE IN INCHES -TOLERANCES-		CAD GENERATED DRAWING, DO NOT MANUALLY UPDATE DO NOT SCALE DRAWING		HYTEC, INC TITLE BSC TROLLEY AND LINKAGE ASSEMBLY #2	
DECIMALS .XX = +/- .06 .XXX = +/- .010	ANGULAR = +/- .30° SURFACE FINISH = 250	SIGNATURE			
FINISH		DESIGNED	W. K. MILLER	DATE	1/18/98
PART NO. D972387-1		DRAWN	W. K. MILLER	DATE	1/18/98
		CHECKED	HARRY SALAZAR	DATE	2/5/98
		ENGR.	T. THOMPSON	DATE	2/5/98
		APPROVED	T. THOMPSON	DATE	2/5/98
				DWG. NO.	D972387
				SIZE	D
				SHEET NO.	1 of 1
				SCALE	1/2
				REVISION	

8 7 6 5 4 3 2 1