

8 7 6 5 4 3 2 1

REVISIONS			
REV.	DESCRIPTION	DATE	APPROVED

D

D

C

C

B

B

A

A

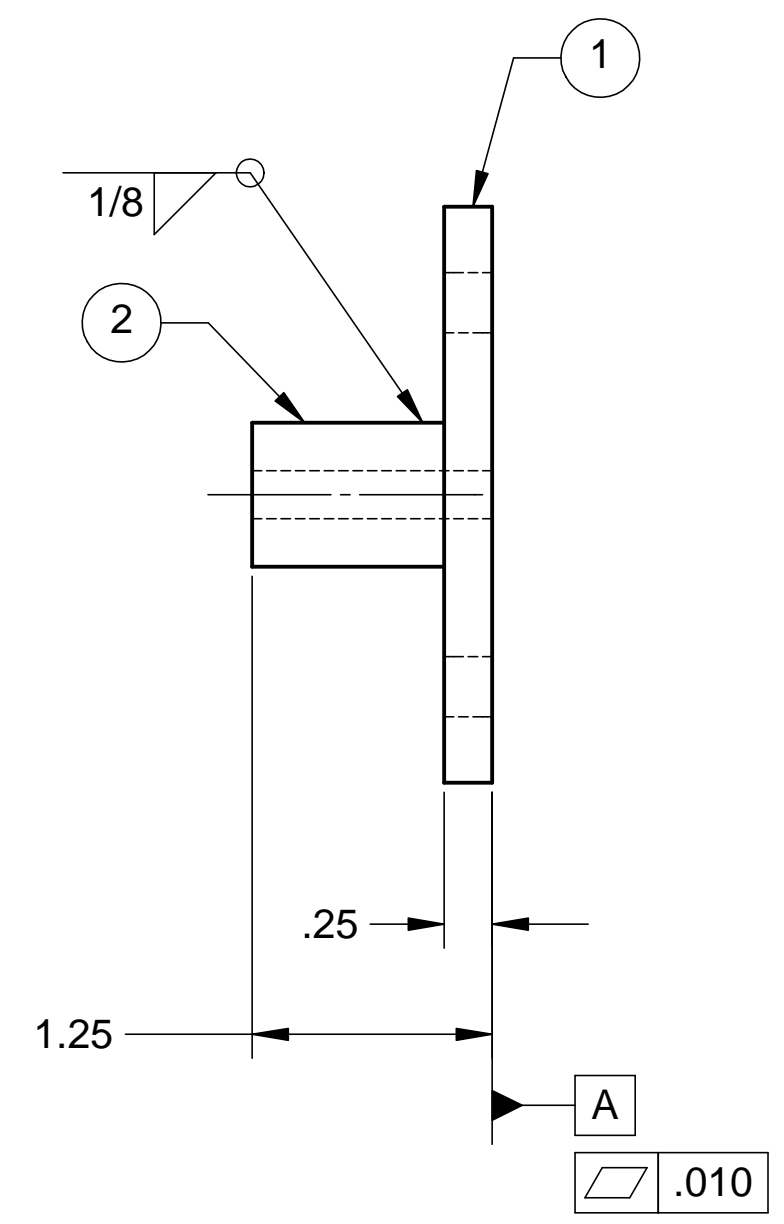
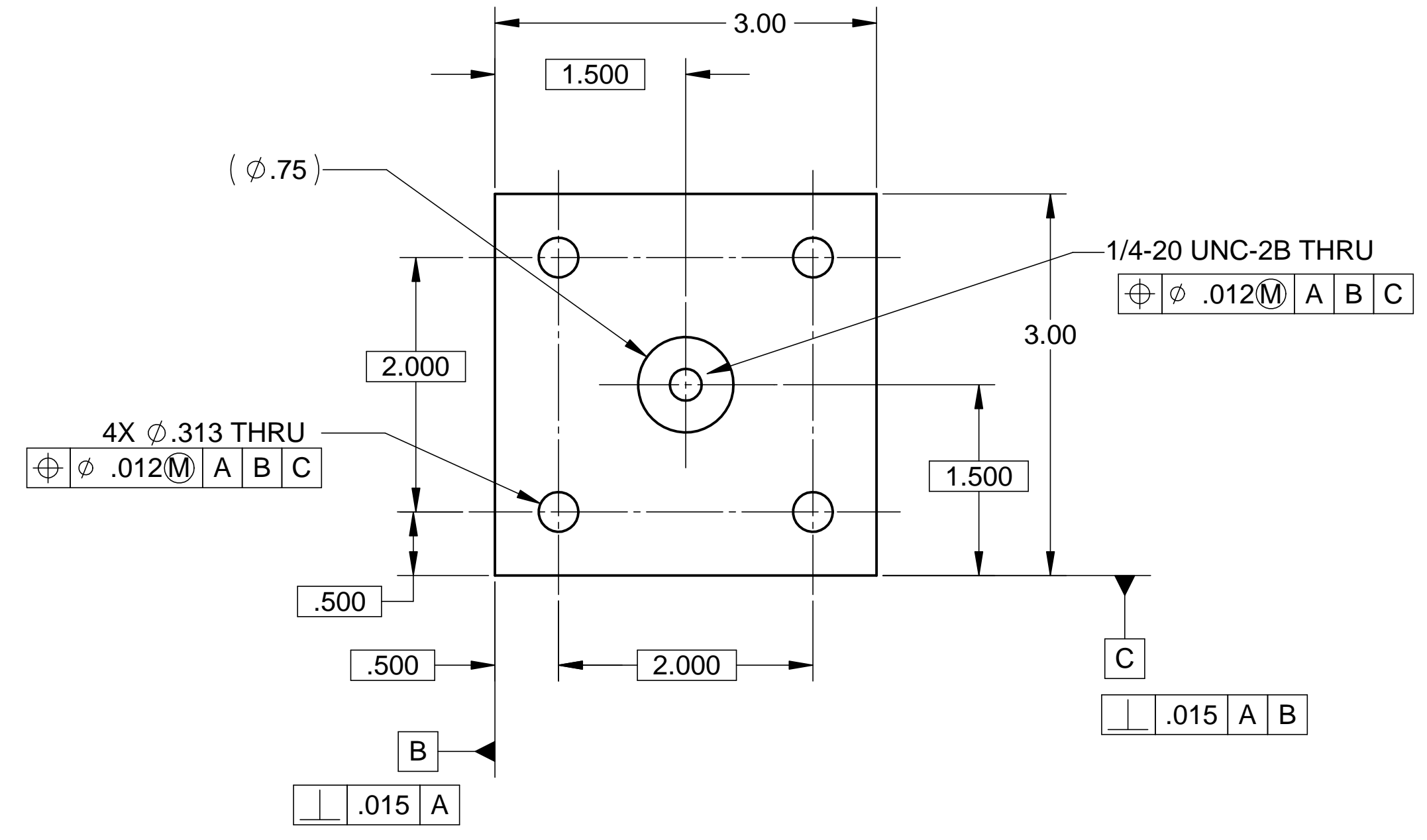

NOTES: UNLESS OTHERWISE SPECIFIED

- ALL DIMENSIONS IN INCHES
- DIMENSIONS AND TOLERANCING PER ASME Y14.5M-1994
- SURFACE TEXTURE PER ANSI/ASME B 46.1-1985
- REMOVE ALL BURRS AND BREAK SHARP EDGES TO A MAXIMUM OF .015
- ALL INSIDE CORNERS TO BE .015 RADIUS MAX
- COUNTERSINK 82 DEGREES ALL TAPPED HOLES TO MAJOR DIAMETER
- COUNTERSINK 82 DEGREES APPROXIMATELY .015 DEEP ALL DRILLED HOLES
- PARTS TO BE THOROUGHLY CLEANED TO REMOVE ALL OIL, GREASE, DIRT AND CHIPS
- PART NUMBER (DRAWING NO. PLUS DASH NO.) TO BE CLEARLY MARKED ON THE PART ITSELF.
- NO SULFUR BASED CUTTING FLUIDS ALLOWED. APPROVED STAINLESS STEEL MACHINE LUBRICANT: RELTON A-9, RELTON
- PART WEIGHS .7 Lbs.

ITEM NO.	QTY.	DESCRIPTION	MATERIAL
1	1	PLATE	303 SST
2	1	ROUNDSTOCK, .75 DIA.	303 SST

PARTS LIST			
UNLESS OTHERWISE SPECIFIED: DIMENSIONS ARE IN INCHES -TOLERANCES-		CAD GENERATED DRAWING, DO NOT MANUALLY UPDATE DO NOT SCALE DRAWING	
DECIMALS .XX = +/- .03 .XXX = +/- .010	ANGULAR = +/- 30' SURFACE FINISH = 250	TITLE <b>HYTEC, INC</b> HAM FORKLIFT - OPTICS TABLE STABILIZER PLATE	
FINISH	SIGNATURE	DATE	DWG. NO.
DESIGNED	W. K. MILLER	3-30-98	SIZE
DRAWN	W. K. MILLER	3-30-98	SHEET NO.
CHECKED	HARRY SALAZAR	-	D972974
ENGR.	T. THOMPSON	-	D
APPROVED	T. THOMPSON	-	1 of 1
PART NO. D972974-1	SCALE	1/1	REVISION

8 7 6 5 4 3 2 1