

7 6 5 4 3 2 1

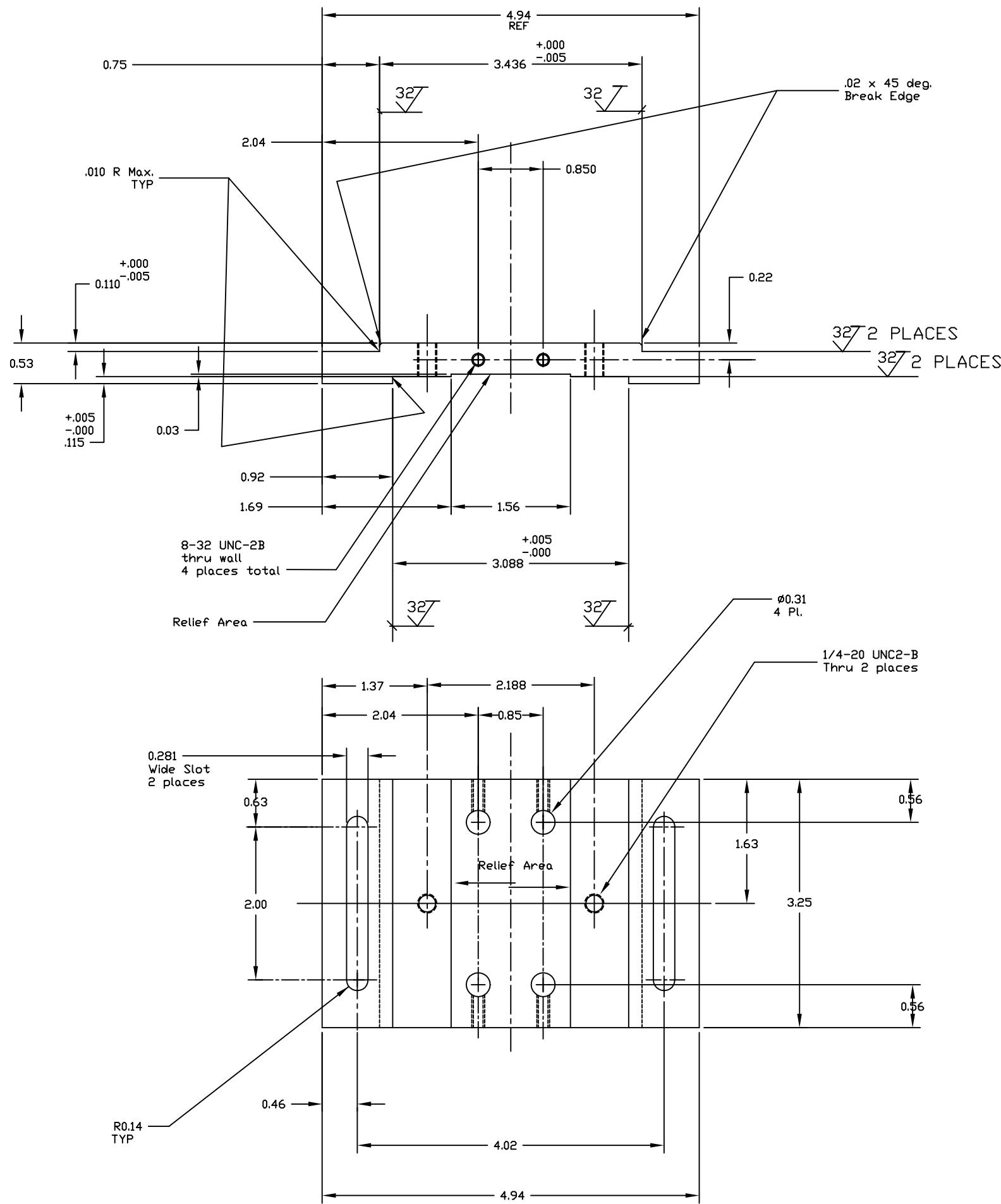
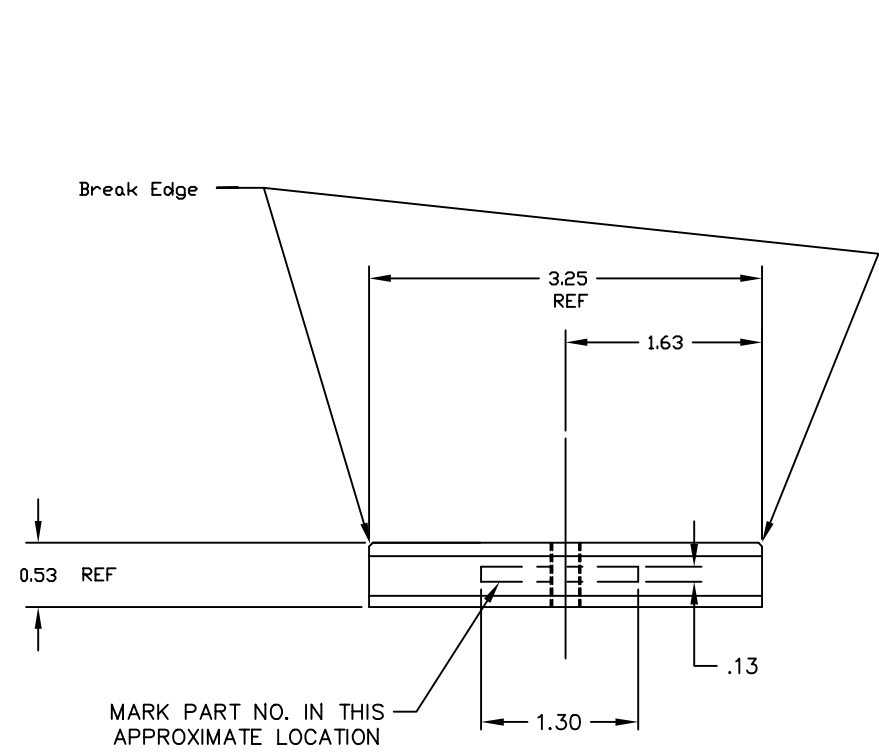

NOTES: (UNLESS OTHERWISE SPECIFIED)

Liquid contaminants, Machining lubricants
Liquids containing hydrocarbons or other
contaminants, other than the machining
fluids specified herein, shall not be
allowed to come into contact with
suspension material at any time. All
machining fluids shall be water soluble and
free of sulfur, chlorine and silicone; such
as Cincinnati Milacron's Cimtech 410
(stainless steel).

Identification: Serial Number
A serial number shall be etched, or
scribed on the part see note drawing
note.
Serial Number Format
The Serial number shall be of the format:
D99xxxx-x-001

Example: D990021-A-001
The drawing number, the revision number,
The sequential part number

REF. MAKE 1 PER ASSEMBLY

5	-	-	-	-
4	-	-	-	-
3	-	-	-	-
2	-	-	-	-
1	-	-	-	-
REV	QTY	PART or DRWG No.	DESCRIPTION	MATERIAL

		UNLESS OTHERWISE SPECIFIED DIMENSIONS ARE IN INCHES								LIGO CALIFORNIA INSTITUTE OF TECHNOLOGY MASSACHUSETTS INSTITUTE OF TECHNOLOGY	
		TOLERANCES: FRACTIONAL ± 1/32 TWO PLACE DECIMAL ± .01 THREE PLACE DECIMAL ± .005 ANGULAR ± 1 deg.		ANGULAR MACH - BEND - FINISHED SURFACE RMS 63 BREAK CORNERS and EDGES REMOVE ALL BURRS						TITLE X-AXIS WAY PLATE	
XXX	XXX	MATERIAL: Alum 6061 T-6	HEAT TREAT: /	FINISH: /	00	PRE-RELEASE	-	-	-	kenn	5-11-99
DWG. NO.	DESCRIPTION	USED ON: XXX	NEXT ASS'Y: XXX	REV	DESCRIPTION	DCN NUMBER	APPR'D	CHECK	DRWN	DATE	CAD FILE D980317-C
REFERENCE DRAWINGS				ISSUE DESCRIPTION						SCALE FULL DWG. NO. D980317-C SHEET	

7 6 5 4 3 2 1