

6

5

4

3

2

1

NOTES:
1. CLEAR ANODIZE PER MIL-A-8625

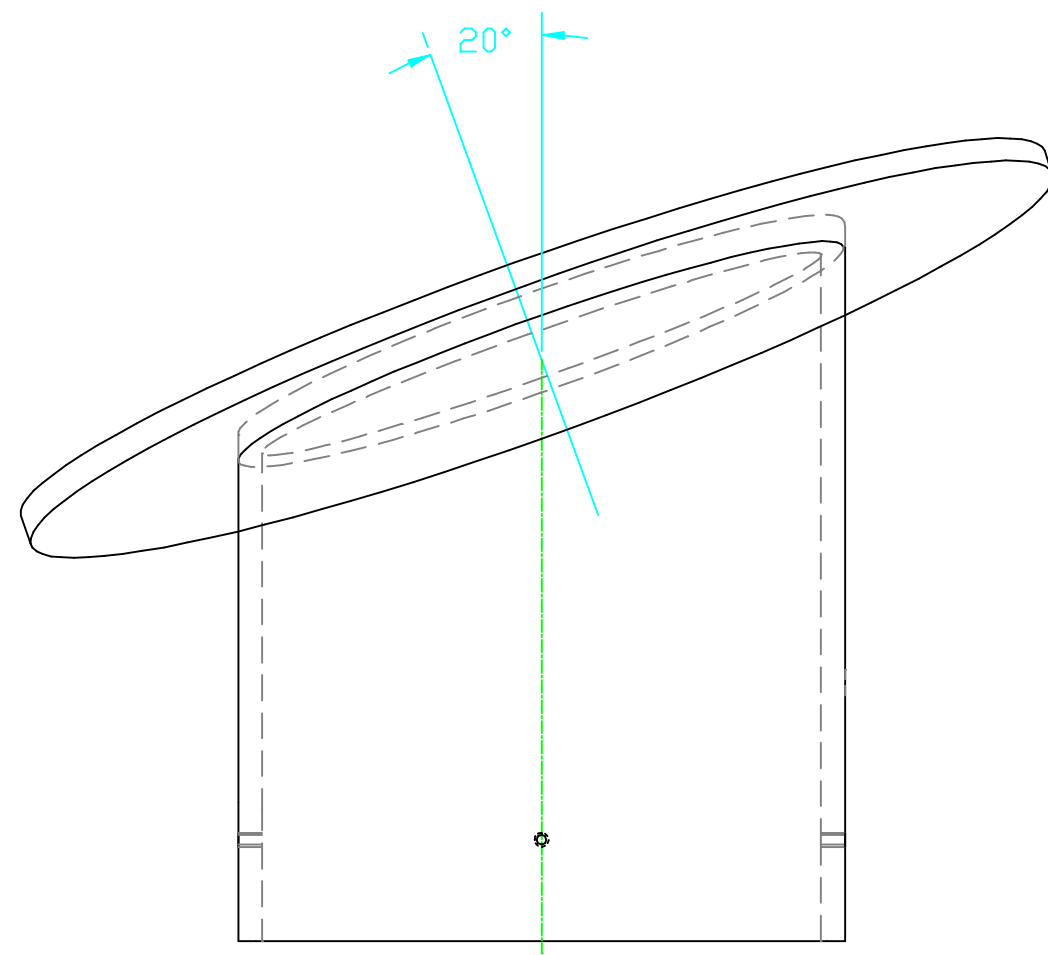

6-32 UNC-2B THRU (4) PLC'S

NOTES:

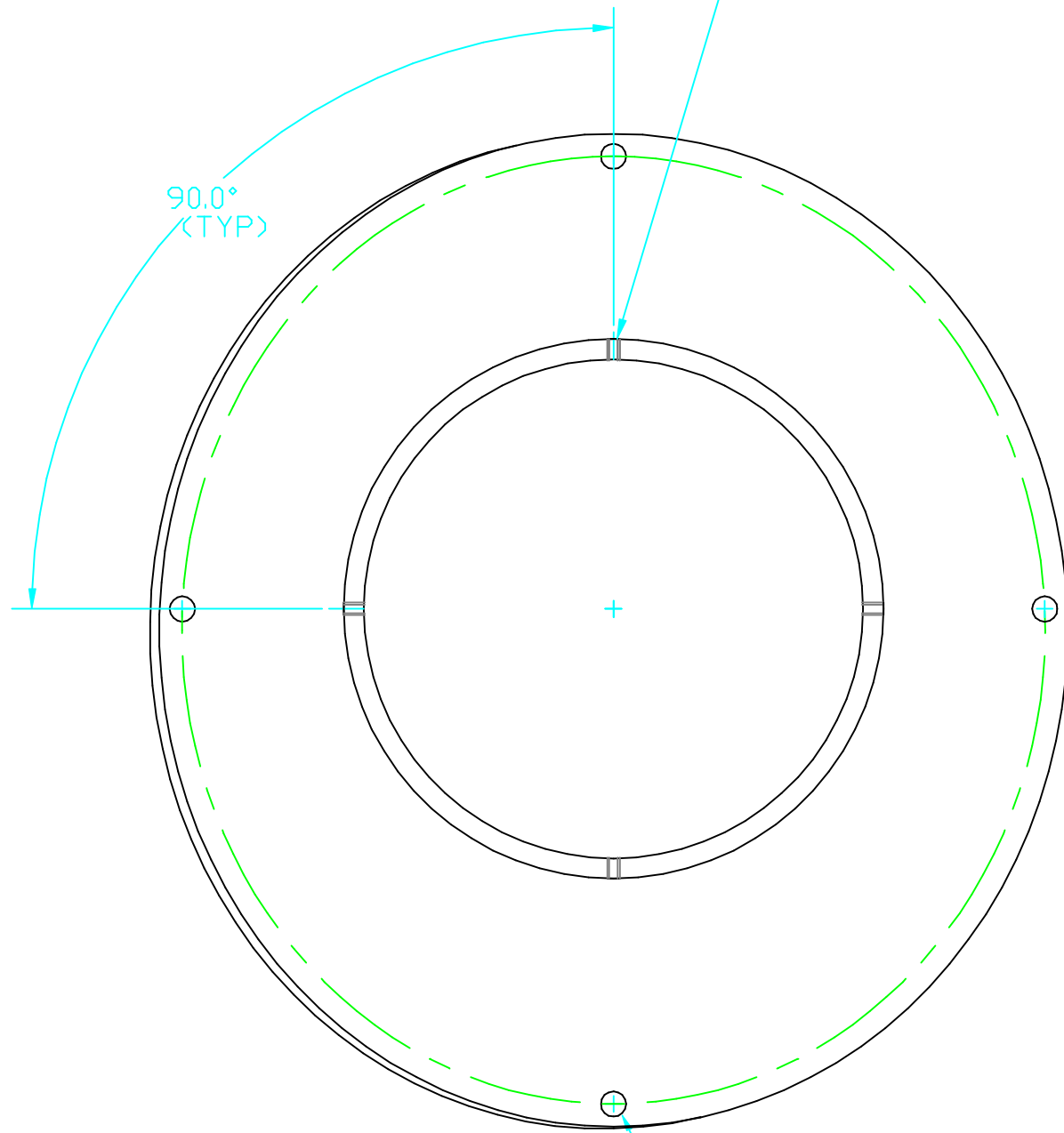

.281Ø THRU (4) HOLES EQ SP ON A 10.250Ø B.C.

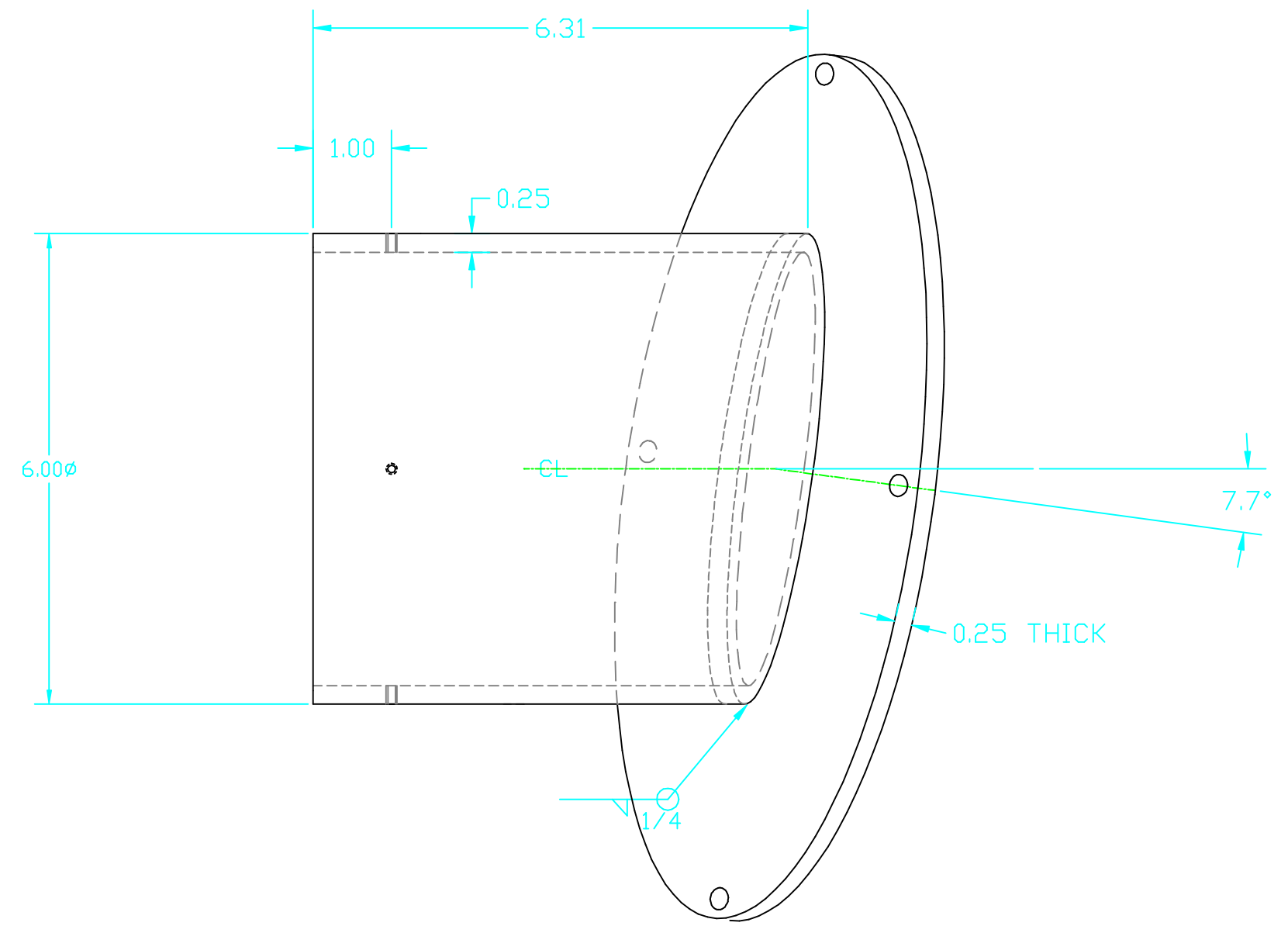

REF	QTY	PART or DRWG No.	CDS										MATERIAL	
PARTS and MATERIAL LIST														
<p>UNLESS OTHERWISE SPECIFIED</p> <p>TOLERANCES: DIMENSIONS ARE IN FEET [cm]</p> <p>FRACTIONAL ± 1/16(.16) FINISHED SURFACE RMS 63</p> <p>ANGULAR ± 1° BREAK CORNERS: .02</p> <p>TWO PLACE DECIMAL ± .01(.025) REMOVE ALL BURRS</p> <p>THREE PLACE DECIMAL ± .005(.013)</p>														
MATERIAL: 6061-T6 ALUM			HEAT TREAT: -			FINISH: -			A INITIAL RELEASE			K.MASDN 3/22/00		
USED ON: -			NEXT ASS'Y: -			PRE-RELEASE			MASDN 6/25/98			D980339-A.dwg		
<p>SCALE 1:2</p> <p>ISSUE DESCRIPTION</p>														
<p>VIEWPORT ADAPTER END ISC TABLE ASSEMBLY</p> <p>D980339-A-D</p> <p>SHEET 1 of 1</p>														

6

5

4

3

2

1