

NOTES: (UNLESS OTHERWISE SPECIFIED)

*Liquid contaminants/Machining Lubricants*  
 Liquids containing hydrocarbons or other contaminants, other than the machining fluids specified herein, shall not be allowed to come into contact with suspension material at any time. All machining fluids shall be water soluble and free of sulfur, chlorine and silicone; such as Cincinnati Milacron's Cimtech 410 (stainless steel).

*Identification Serial Number*  
 A serial number shall be etched, or scribed on the part see note drawing note.

*Serial Number Format*  
 The Serial number shall be of the format: D99xxx-x-001

Example: D990021-A-001  
 The drawing number, The revision number, The sequential part number

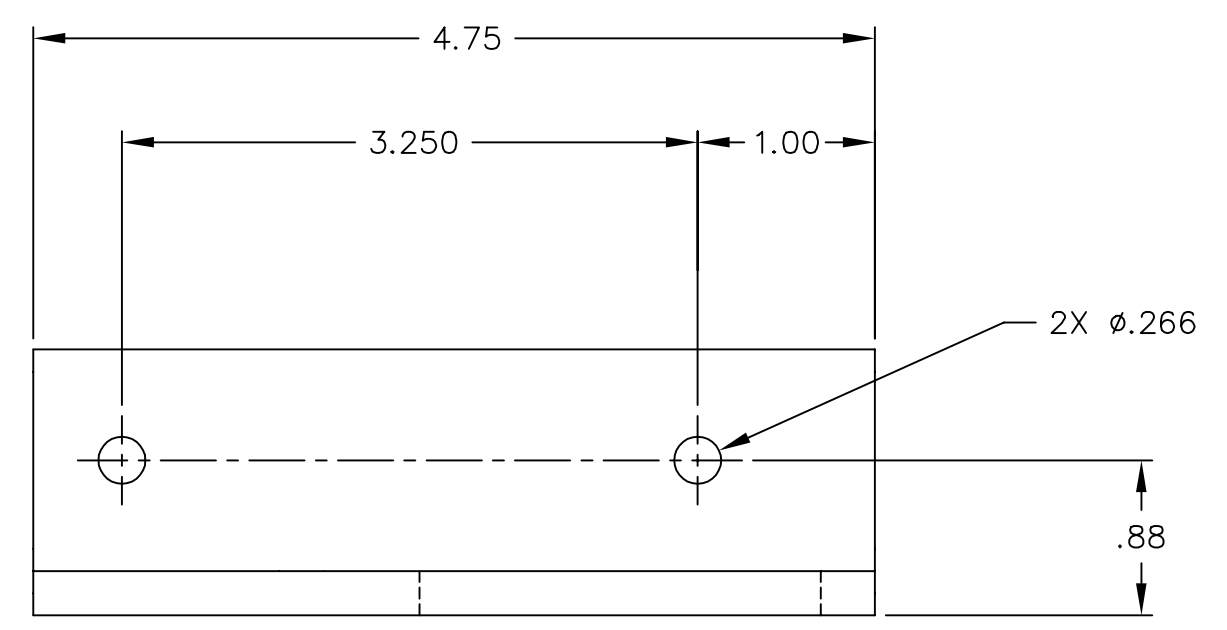
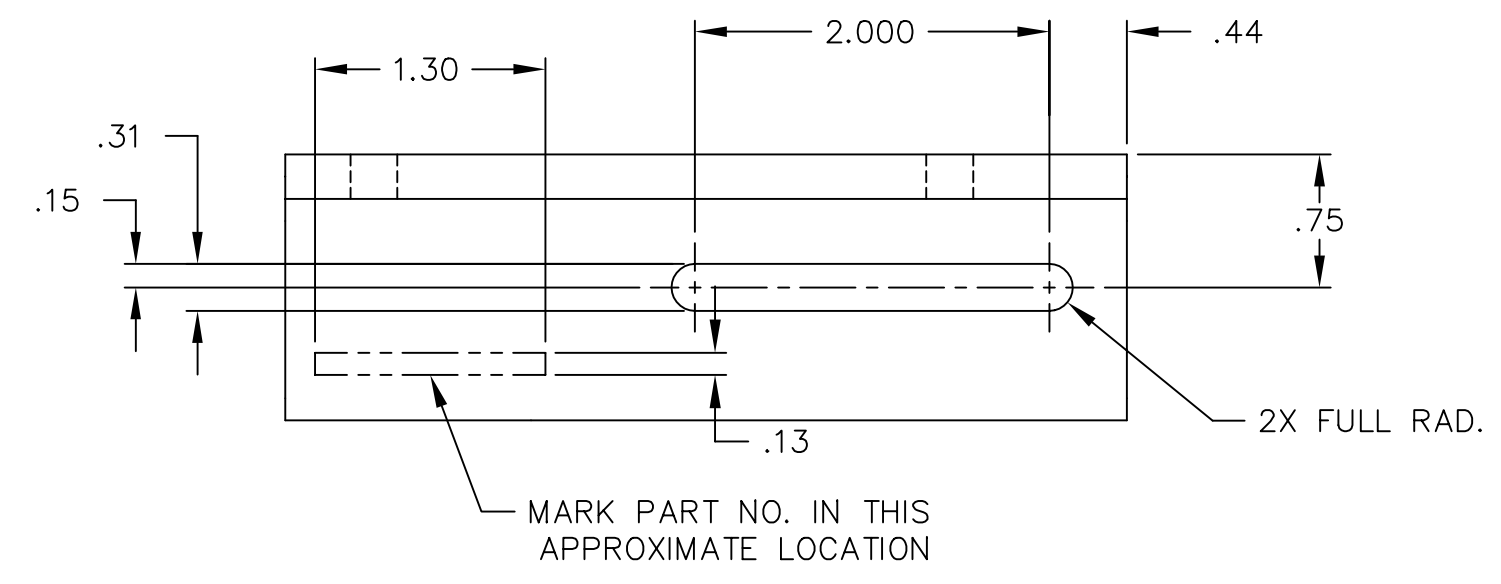
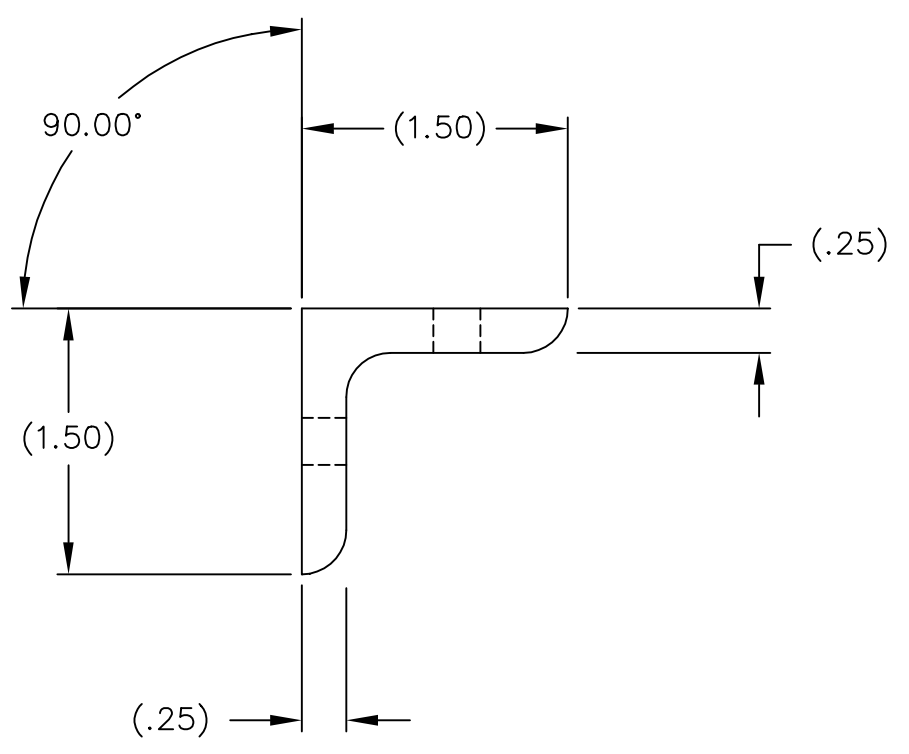

ref. 1 per assembly

REF	QTY	PART or DRWG No.	DESCRIPTION	MATERIAL
			PARTS and MATERIAL LIST	
<b>LIGO</b> CALIFORNIA INSTITUTE OF TECHNOLOGY MASSACHUSETTS INSTITUTE OF TECHNOLOGY				
BRKT., REAR-RIGHT, ETM RETAINING				
CAD FILE		SIZE	DWG. NO.	
D980648-B		C	D980648-B	
SCALE				SHEET
1 : 1				1 OF 1

UNLESS OTHERWISE SPECIFIED DIMENSIONS ARE IN FEET (in)			
TOLERANCES:		THREE PLACE DECIMAL ± .005	
FRACTIONAL ± 1/16		FINISHED SURFACE RMS 63	
ANGULAR ± .25		BREAK CORNERS IN: .015 OUT: .015	
ANGULAR MACH → BEND →		REMOVE ALL BURRS	
TWO PLACE DECIMAL ± .01			
MATERIAL:	HEAT TREAT:	FINISH:	
1.5 X 1.5 X .25 THK.	/		
6061 T-6 ALUM. Angle			
USED ON: XXX	NEXT ASS'Y: XXX		

REV	DESCRIPTION	DCN NUMBER	APPR'D	CHECK	DRWN	DATE
B	FOR FABRICATION				kenm	6-2-99
00	PRE-RELEASE	-	-	-	CHAPUT	11-3-98