

NOTES: (UNLESS OTHERWISE SPECIFIED)

- CUTTING FLUIDS TO BE WATER SOLUBLE AND FREE OF SULFUR, CHLORINE, & SILICONE.
- STEEL STAMP OR ENGRAVE THE DRAWING PART NUMBER ON NOTED FACE OF PART FOLLOWED BY 'S/N', THEN A THREE DIGIT SERIAL NUMBER. SERIAL NUMBERS TO START AT 001 FOR FIRST PART AND PROCEED IN A CONSECUTIVE MANNER TO A MAXIMUM OF 999, FOR EACH SUCCEEDING PART PRODUCED. USE .013 HIGH CHARACTERS. EXAMPLE: D990038-A S/N 001

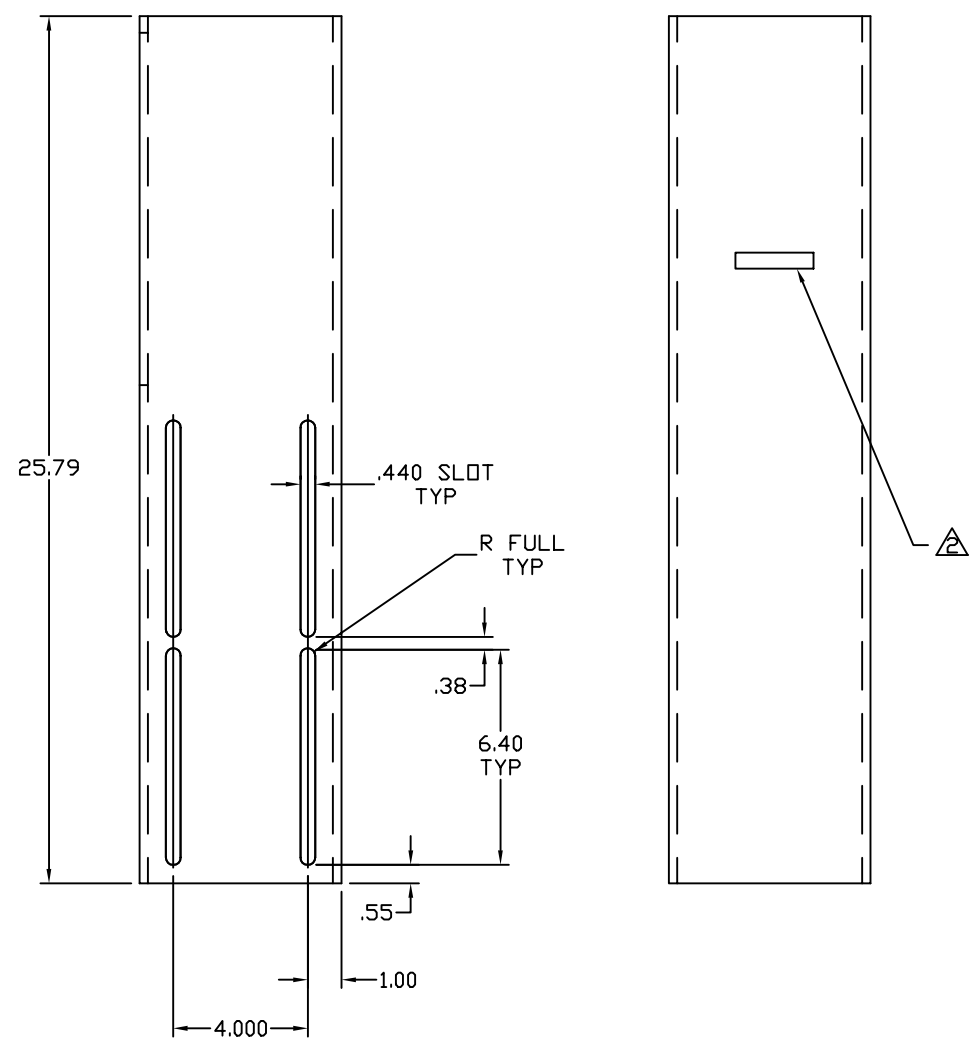
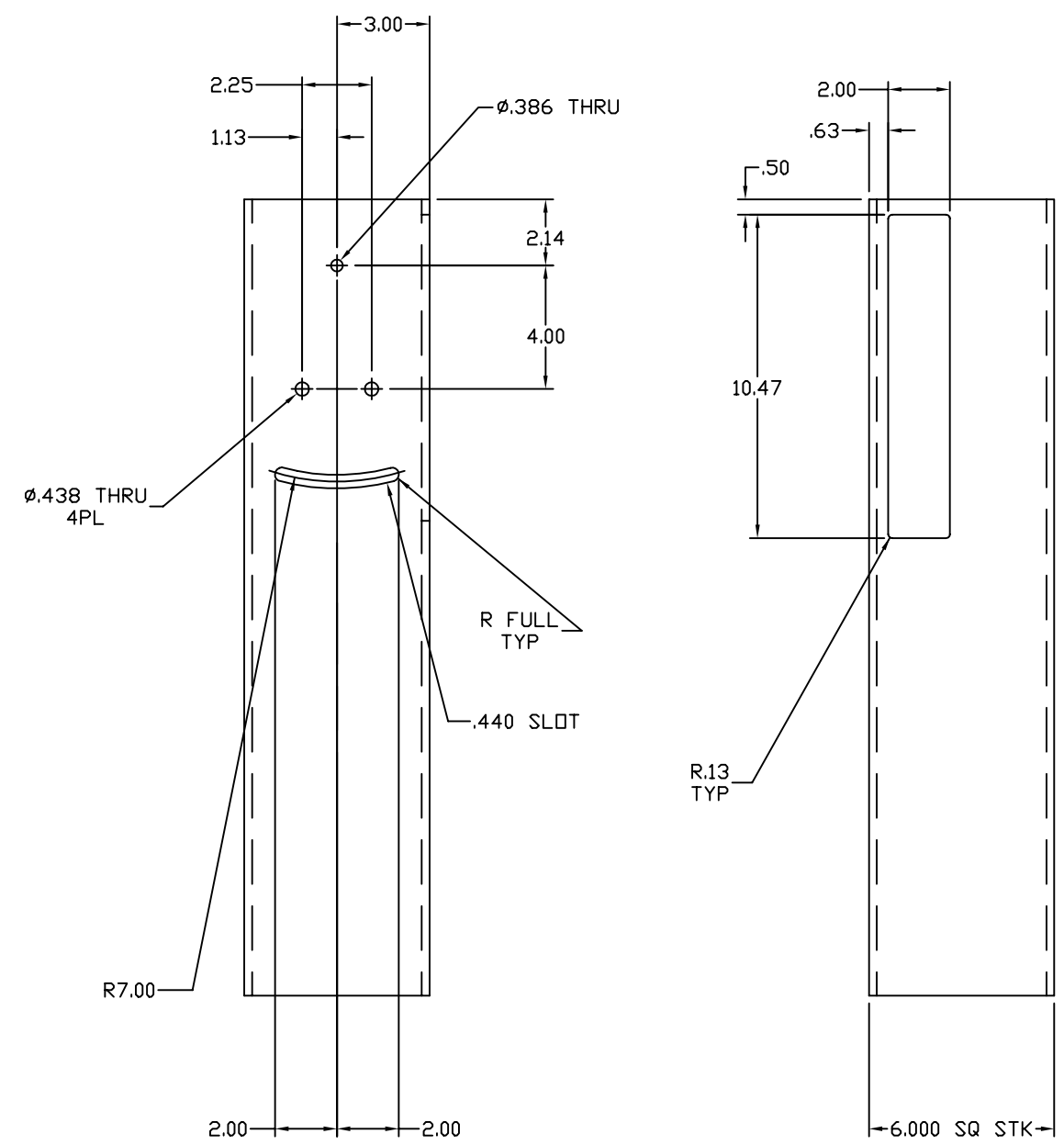

		UNLESS OTHERWISE SPECIFIED DIMENSIONS ARE IN INCHES							LIGO CALIFORNIA INSTITUTE OF TECHNOLOGY MASSACHUSETTS INSTITUTE OF TECHNOLOGY		
		TOLERANCES: FRACTIONAL ± ANGULAR ± ANGULARMACH ± BEND ± TWO PLACE DECIMAL ±.01		THREE PLACE DECIMAL ±.005 FINISHED SURFACE RMS BREAK CORNERS IN: .005-.010 REMOVE ALL BURRS						CAVITY BEAM DUMP HOUSING TUBE, BSC4, 2KITMXAR1, 2KITMYAR1, 2KRMHR3	
		MATERIAL: 6061-T6 ALU TUBING 6" SQ, 1/4" WALL	HEAT TREAT:	FINISH:	A	DCN E990210	Conley	5-18-99	CAD FILE D990252-Adwg	SIZE DWG. NO. B	D990252-A
DWG. NO.	DESCRIPTION	USED ON:	NEXT ASS'Y: D990141	REV	DESCRIPTION	APPR'D	CHECK	DRWN	DATE	SCALE	SHEET
6	REFERENCE DRAWINGS	5	4	3	2	1	1 OF 1				