

REV.	DATE	DCN #	DRAWING TREE #
v1	01 MAR 2011	E0900502	E0900353
-	-	-	-
-	-	-	-

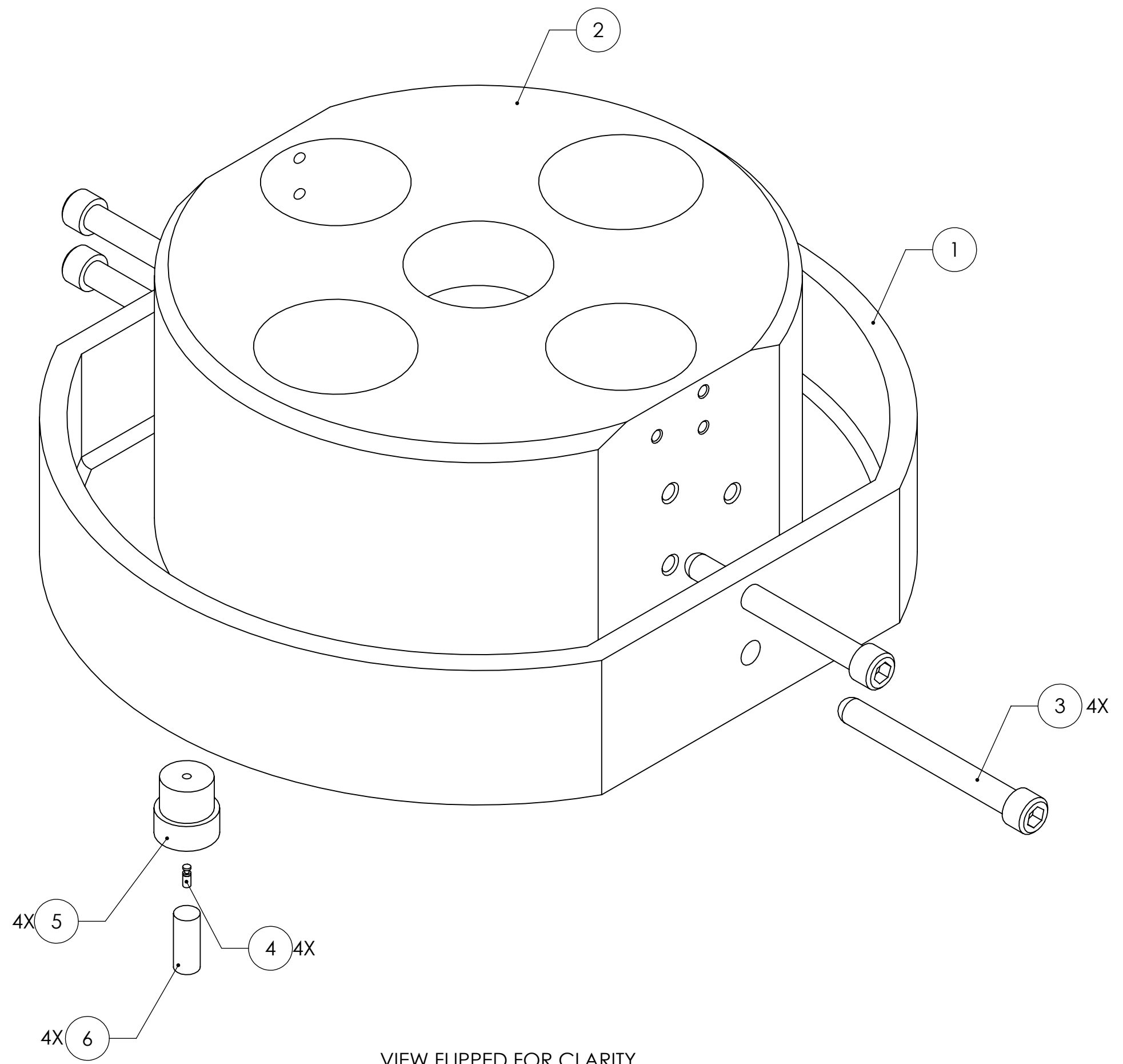

ITEM NO.	PART NUMBER	DESCRIPTION	MATERIAL	REQ	SPARE	TOTAL
6	D1100043	MAGNET GLUING WEIGHT	6061-T6 Al	4	1	5
5	D1002341	MAGNET BUSHING FOR HSTS RING FIXTURE	PFA440 HP (PRESHRUNK)	4	1	5
4	D020661	MAGNET-STANDOFF ASSEMBLY, INT. MASS	--	4	1	5
3	D030022	SCREW, SOCKET HEAD CAP, 1/4-20 UNC-3A X 2.25 LONG, FULLY THREADED, ROUNDED END	300 SSSL	4	1	5
2	D0901792	INTERMEDIATE MASS, HSTS	6061-T6 Al	1	-	1
1	D1002607	INTERMEDIATE MASS RING FIXTURE	6061-T6 Al	1	-	1

NOTES AND TOLERANCES: (UNLESS OTHERWISE SPECIFIED)				CALIFORNIA INSTITUTE OF TECHNOLOGY MASSACHUSETTS INSTITUTE OF TECHNOLOGY		PART NAME INTERMEDIATE MASS RING FIXTURE ASSEMBLY						
MATERIAL		FINISH		SYSTEM	SUB-SYSTEM	DESIGNER	B. MOORE	06 OCT 2010	SIZE	DWG. NO.	REV.	
N/A		N/A μinch		ADVANCED LIGO	SUS	DRAFTER	B. MOORE	07 OCT 2010	c	D1002606	v1	
NEXT ASSY				D040391		CHECKER	M. MEYER	08 OCT 2010	APPROVAL	SCALE: 1:1	PROJECTION:	SHEET 1 OF 1