



LIGO Laboratory / LIGO Scientific Collaboration

E1000523-v5

LIGO

6 October 2011

Trillium Pod Assembly Procedure

A. Le Roux, M. Hillard, R. Mitchell

Distribution of this document:
Advanced LIGO Project

This is an internal working note
of the LIGO Laboratory.

California Institute of Technology
LIGO Project – MS 18-34
1200 E. California Blvd.
Pasadena, CA 91125
Phone (626) 395-2129
Fax (626) 304-9834
E-mail: info@ligo.caltech.edu

Massachusetts Institute of Technology
LIGO Project – NW22-295
185 Albany St
Cambridge, MA 02139
Phone (617) 253-4824
Fax (617) 253-7014
E-mail: info@ligo.mit.edu

LIGO Hanford Observatory
P.O. Box 1970
Mail Stop S9-02
Richland WA 99352
Phone 509-372-8106
Fax 509-372-8137

LIGO Livingston Observatory
P.O. Box 940
Livingston, LA 70754
Phone 225-686-3100
Fax 225-686-7189

Clean room standards:

For a clean assembly, all LIGO standards should be followed, as presented in the latest version of the **LIGO Contamination Control Plan (E0900047)**. Clean room garb including UHV gloves should be worn when working with clean parts.

All tools that come in contact with assembly should be cleaned to class B standards.

Assembly will be done under a portable clean room. Anytime a part of the assembly is not covered by the portable clean room or not being actively worked on, it should be covered with appropriate clean covers (C3 polyester or equivalent).

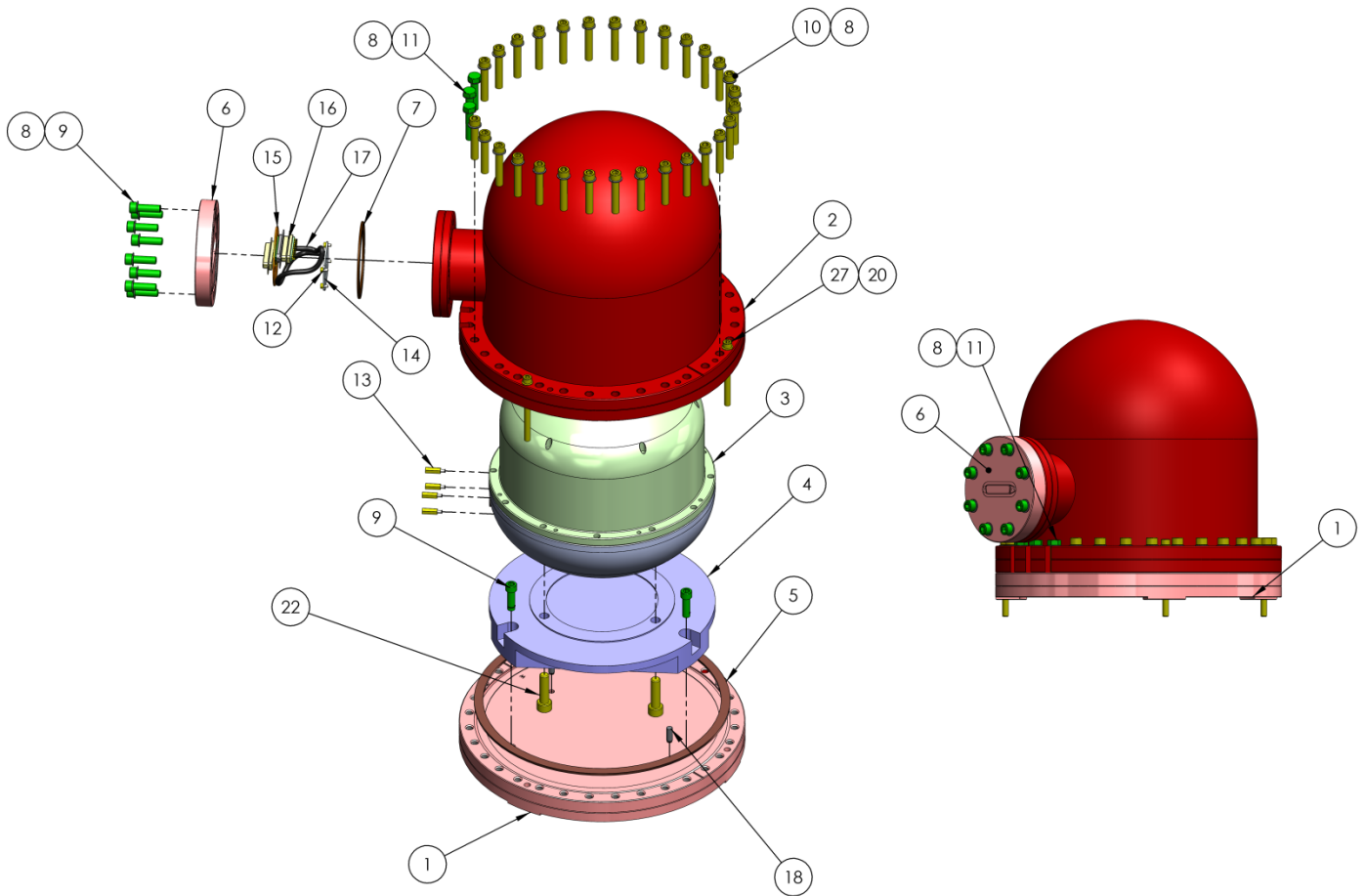

Figure 1: Exploded View of the whole Assembly

27	McMaster_92196A554	Screw SHCS 1/4-20 x 3" lg 1" min thread	18-8 SSSL	3	3	-
26	McMaster_90298A716	Shoulder Screw 1/2" OD x 1 1/2lg, 3/8-16 thd	18-8 SSSL	1	-	-
25	D0901819	Trillium Pod Locating Eccentric	304 SSSL	1	-	-
24	McMASTER_92146A030	SPRING WASHER 5/16 ID	18-8 SSSL	3	3	3
23	McMASTER_91111A135	M10SPRING LOCK WASHER	18-8 SSSL	3	3	3
22	D1002584	SCREW M10 X 1mm X 35mm LG	18-8 SSSL	3	3	3
21	D0902547	Trillium Pod, Loading, Slider Foot, Asem	N/A	-	-	3
20	UC_COMPONENTS_WFV-25	Vented Washer, .255 ID X .468 OD X .032THK #1/4	18-8 SSSL	3	3	6
19	UC Components_C-2024-A	SHCS, 1/4"-20 x 1.5 lg, Ag plated	18-8 SSSL	-	-	6
18	McMaster_90145A539	Dowel Pin 1/4" (.2501) x 5/8" L 18.8 SST	18-8 Stainless	2	2	2
17		Wire	PVC Rigid	1	1	1
16		Cconnector D-Sub 25 pin	Material <not specified>	1	1	1
15		Trillium Flange PCB Assy	N/A	1	1	1
14		Trillium Custom Interface Circuit Board	Material <not specified>	1	1	1
13	McMaster_93655A710	Standoff, Male/Female Hex, M3 x 16mm	18-8 SSSL	4	4	1
12	McMaster_91292A110	M3x5 SCHS 18.8 SST	18-8 SSSL	4	4	1
11	U-C Components_H-3124-NA	Screw Hex Head 5/16-24 x 1.5" lg, AG plated	18-8 SSSL	3	3	3
10	U-C Components_C-3128-NA	Screw SHCS 5/16-24 UNF-2A x 1 3/4 lg Ag plated	18-8 SSSL	29	29	29
9	U-C Components_C-3116-NA	Screw shcs 5/16-24 UNF-2A X 1" lg Ag plated	Ag-PLATED 300 SSSL	11	11	11
8	UC_COMPONENTS_WFV-31	Washer Vented, .328 ID X .562 OD X .032 THK #5/16	18-8 SSSL	40	40	40
7	Nor-Cal_G-450	CF Flange Gasket 4.5" Nominal OD	COPPER	1	1	1
6	Accu-Glass_100220	25 Pin D-Type Feedthrough for a 4.5" CF Flange	AISI 304	1	1	1
5	Nor-Cal_G-1200	CF Flange Gasket 12" Nominal OD	Copper	1	1	1
4	D0900651	Trillium Pod Interposer	6061-T6 Al	1	1	1
3	D0900647	Trillium 240 Seismometer	N/A	1	1	1
2	D0900649	Trillium 240 Pod Tophat	304 SSSL	1	1	1
1	D0900650	Trillium Pod Base Flange	304 SSSL	1	1	1
ITEM NO.	PART NUMBER	DESCRIPTION	MATERIAL	2: As Mounted in Stage1/REQ	1: POD Only/QTY.	3: Setup for Loading into Stage1/QTY.

Figure 2: Bill of Material of the Trillium Pod Assembly

1. Press the two undersized 1/4" x 5/8" long Dowel Pin into the Trillium Pod Base Flange (D0900650) .Pin should sit 0.25" proud of the mating surface. Ensure that dowel pin does not have any free movement after it is inserted and that it cannot be removed. If the dowel pin can be moved in any way, it must be peened in place using a center punch on the side of the hole where the loose dowel is installed

Hardware:

- (2) Undersized (.2495 max diameter) 1/4" x 5/8" long Dowel Pin

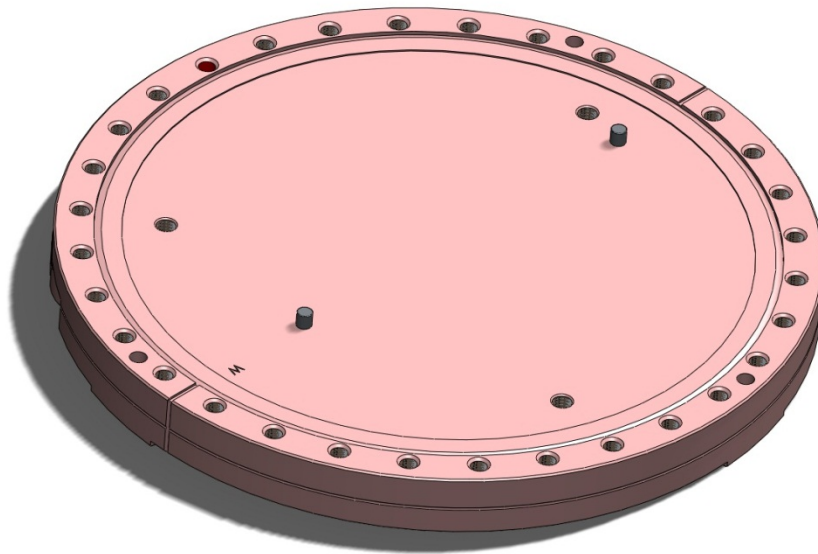

Figure 3: Dowel Pins pressed into the Trillium Pod Base Flange (D0900650)

2. Mount the Trillium 240 Seismometer on the Trillium Interposer (D0900651), making sure to align "W" markings on the two parts. Torque screws to **50 in.lbs.**

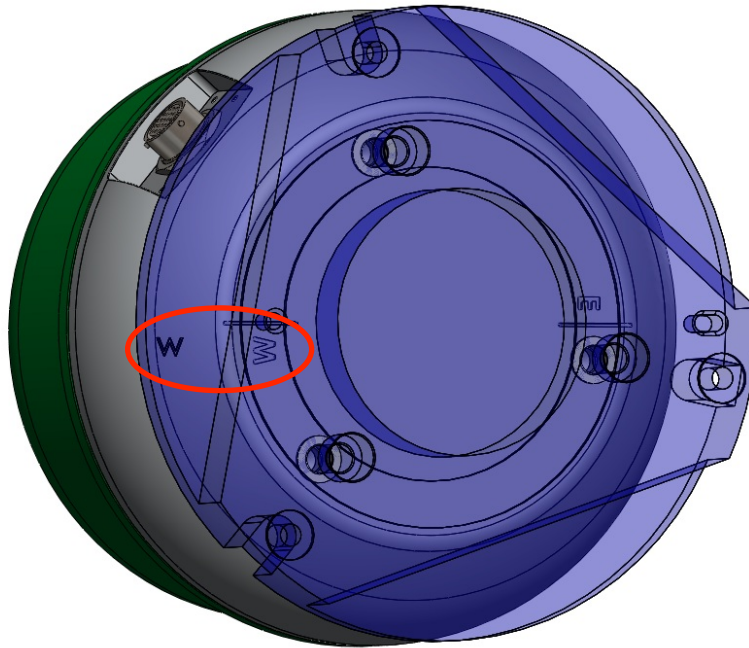

Figure 4: The Trillium 240 Seismometer is seated on the Trillium Interposer (D0900651) with the "W" markings aligned as circled on the screen shot above

Hardware:

- (3) M10 x 1mm x 35mm long Stainless Steel SHCS
- (3) M10 Springs Lock Washers

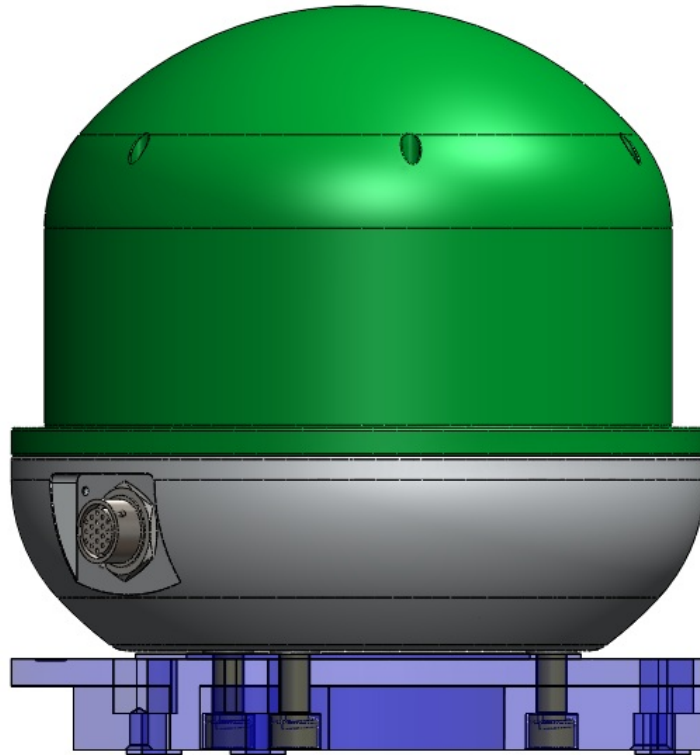

Figure 5: Trillium 240 Seismometer mounted on the Trillium Interposer (D0900651)

3. Place the Trillium 240 Seismometer and the Trillium Interposer (D0900651), on the Trillium Pod Base Flange (D0900650) allowing pins to sit properly in hole and slot and aligning “W” markings. Torque screws to **250 in.lbs.**

Hardware:

- (3) 5/16”-24 x 1” Ag plated SHCS
- (3) 5/16” Spring Lock Washers

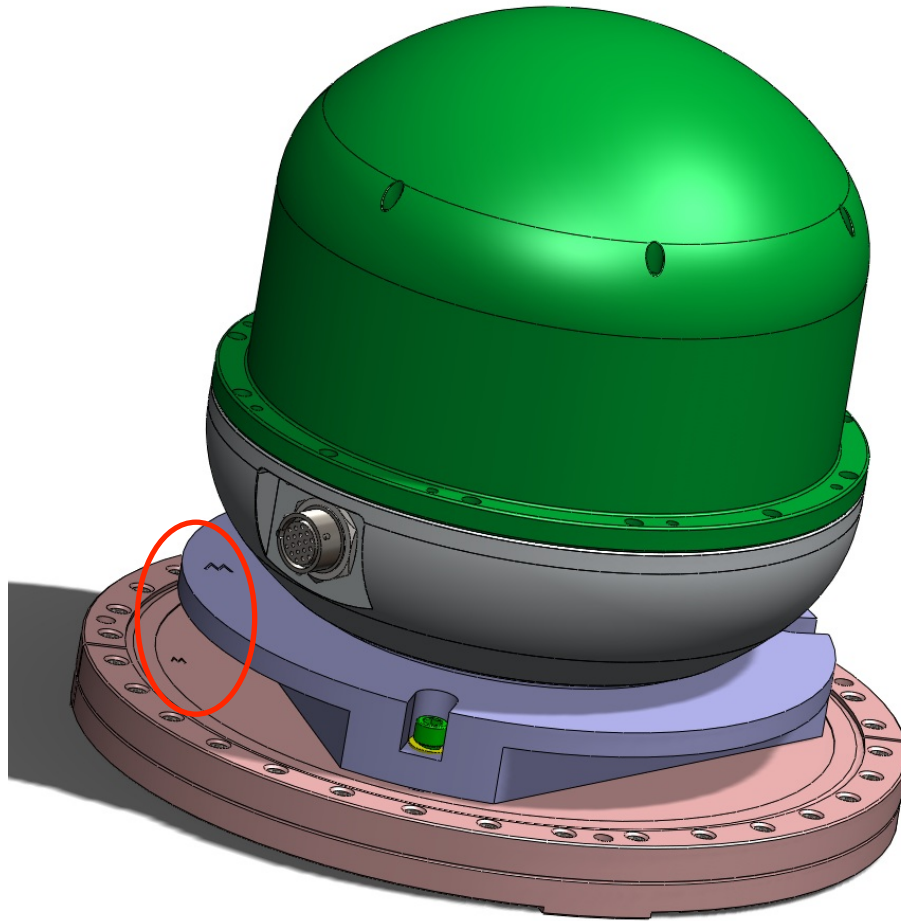

Figure 6: Sub-assembly composed of the Trillium 240 Seismometer and the Trillium Interposer (D0900651) mounted on the Trillium Pod Base Flange (D0900650)

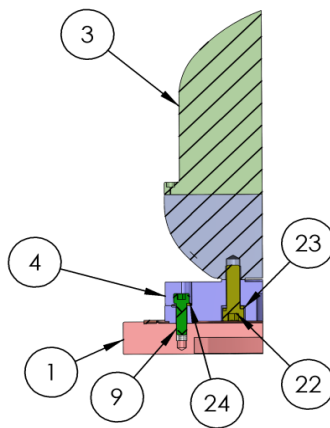

Figure 7: Section of the Sub-Assembly above (see Figure 2: Bill of Material on Page 3 for the Number)

4. Insert four M3 x 14mm long Standoff in the Trillium 240 Seismometer. Insert two M3 Washers on the two top Standoffs. Snug the four M3 x 14mm long Standoff in the Trillium 240 Seismometer.

Hardware:

(4) M3 x 14mm long Standoff

(4) M3 Washers

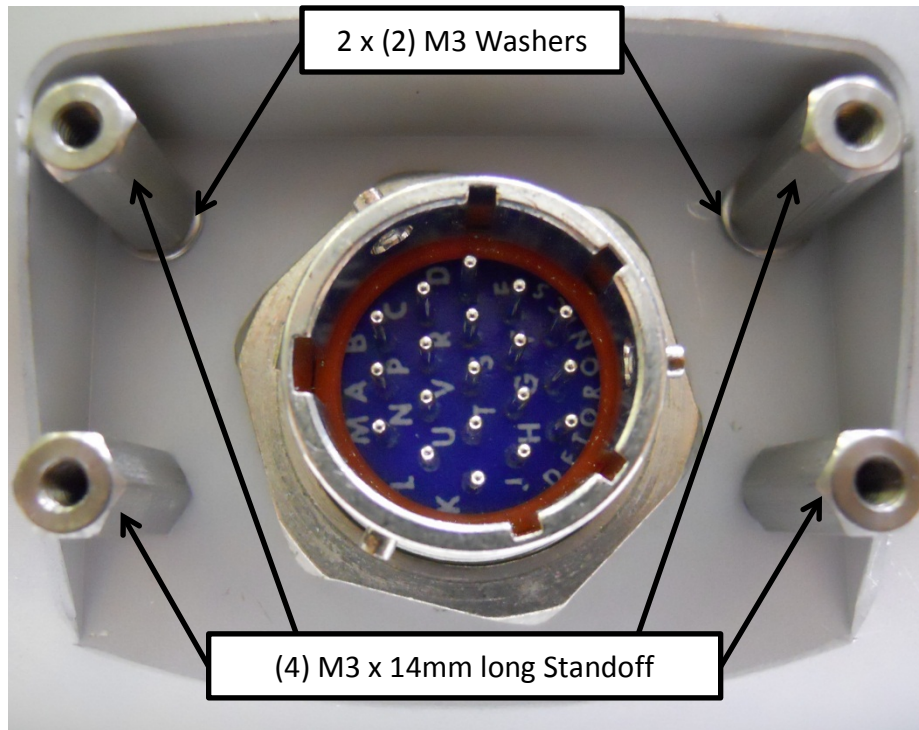

Figure 8: M3 x14mm Standoffs mounted on the Trillium 240 Seismometer

5. After wiping it down with a clean cloth and methanol, place the Copper Gasket on the knife edge of the Trillium Pod Base Flange (D0900650)
6. Place the Trillium Pod Chamber Top Hat (D0900649) over the Trillium Pod Base Flange (D0900650), aligning the vertical edge lines on both part.

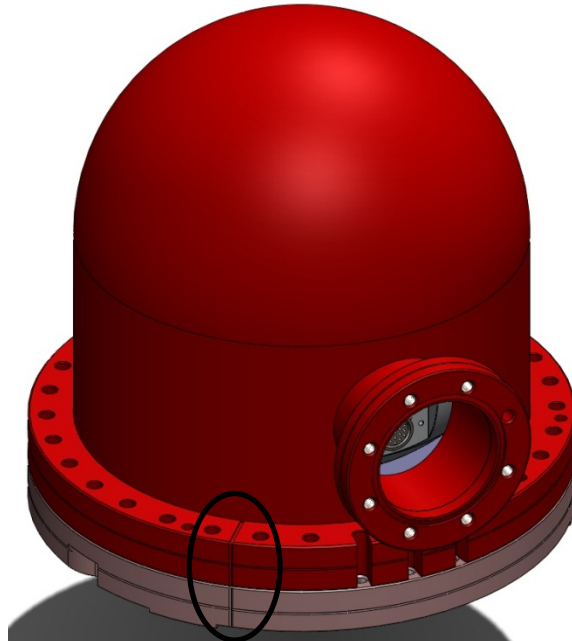

Figure 9: Trillium Pod Chamber Top Hat (D0900649) over the Trillium Pod Base Flange (D0900650), with the vertical edge lines aligned on both part

7. Insert connector PCB into Top Hat Port and onto the Trillium connector, making sure that the board is sitting flat against the four standoffs. Use four M3 x 5mm long SHCS with four M3 Washers, to fasten the PCB to the standoffs.

Hardware:

(4) M3 x 5mm long SHCS

(4) M3 Washers

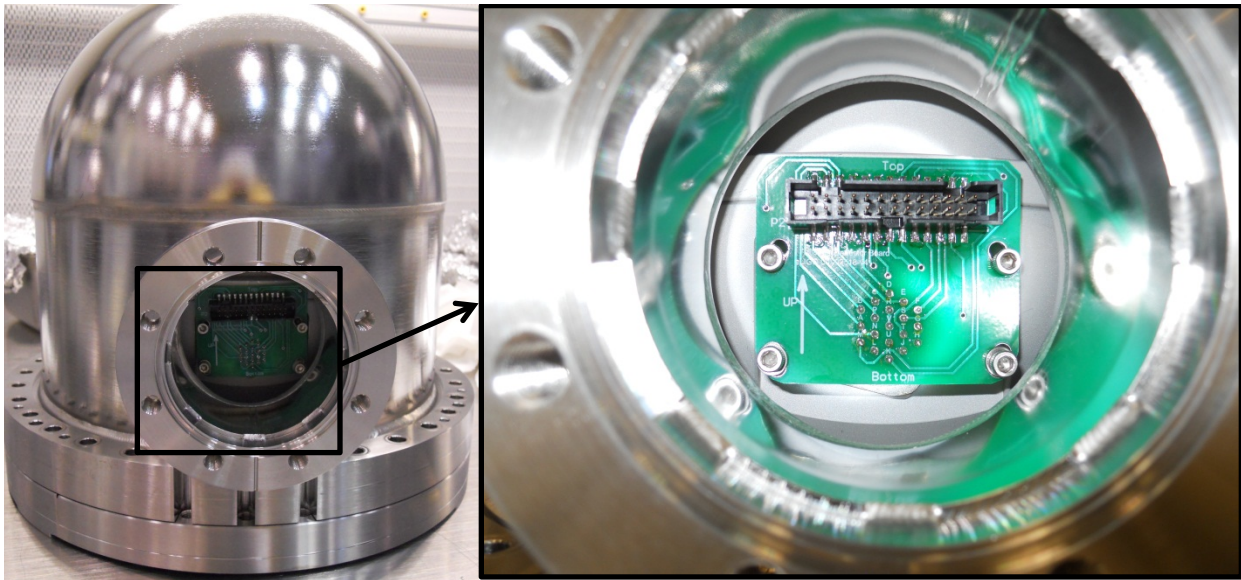

8. Fasten the Trillium Pod Chamber Top Hat (D0900649) to the Trillium Pod Base Flange (D0900650) using thirty-three 5/16"-18x1.75" Ag Plated SHCS, three 5/16"-18x1.5" Ag Plated Hex Head and thirty-six 5/16" Vented Washers as shown on the Figure 10 Tighten them hand tight. Check to see that the flange faces are parallel. Tighten 2 bolts diametrically opposite to an intermediate torque value (for example 150 in.lbs), repeat this operation with 2 other bolts oriented ~ 90 degrees from the two first ones for alignment purposes. Then torque all the bolts incrementally up to final torque value, using a circular clockwise pattern (250 in.lbs, **345 in.lbs** [This torque value is higher than the Nor-Cal Spec.: 190 in.lbs, in order to make sure that the two flange faces are brought metal to metal]).

Hardware:

- (33) 5/16"-24 x 1.75" Ag plated SHCS
- (3) 5/16"-24 x 1.5" Ag plated HHCS
- (36) 5/16" Vented Washers

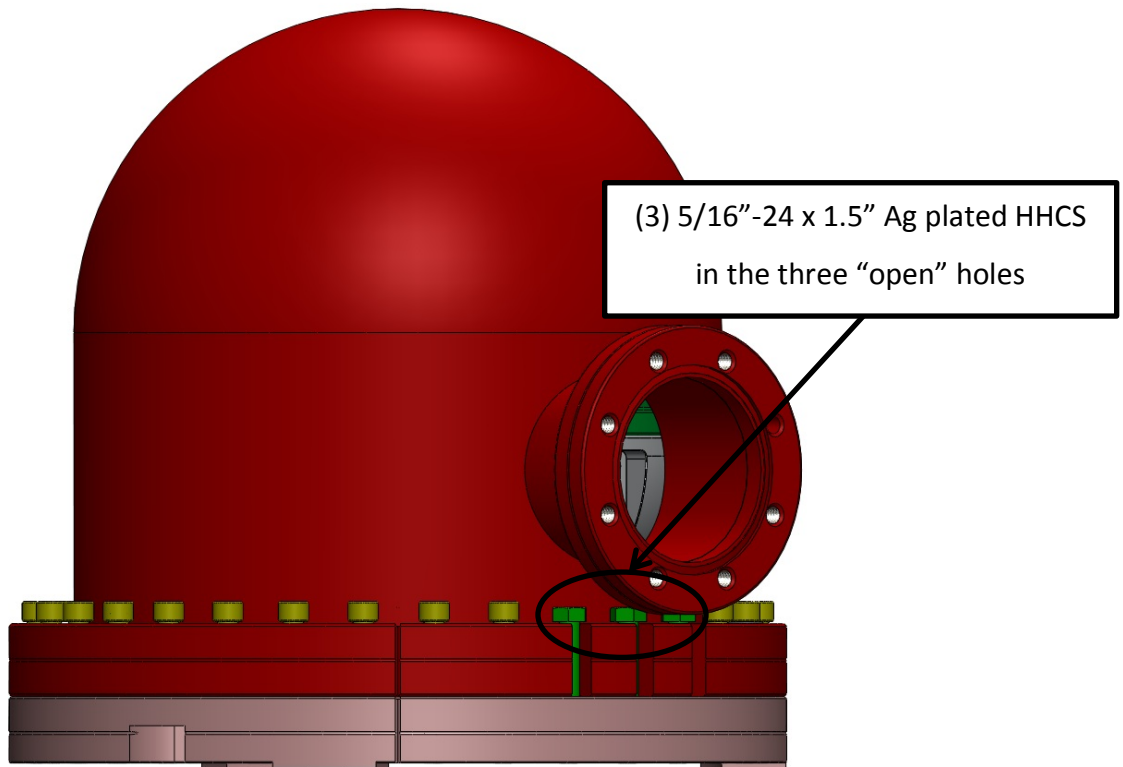

Figure 10: Trillium Pod Chamber Top Hat (D0900649) bolted down on the Trillium Pod Base Flange (D0900650)

9. Check that the flange faces are metal to metal.

10. Plug Cable to the connector PCB, then insert CF450_250N copper seal and finally plug the other end of the cable to the Feed.

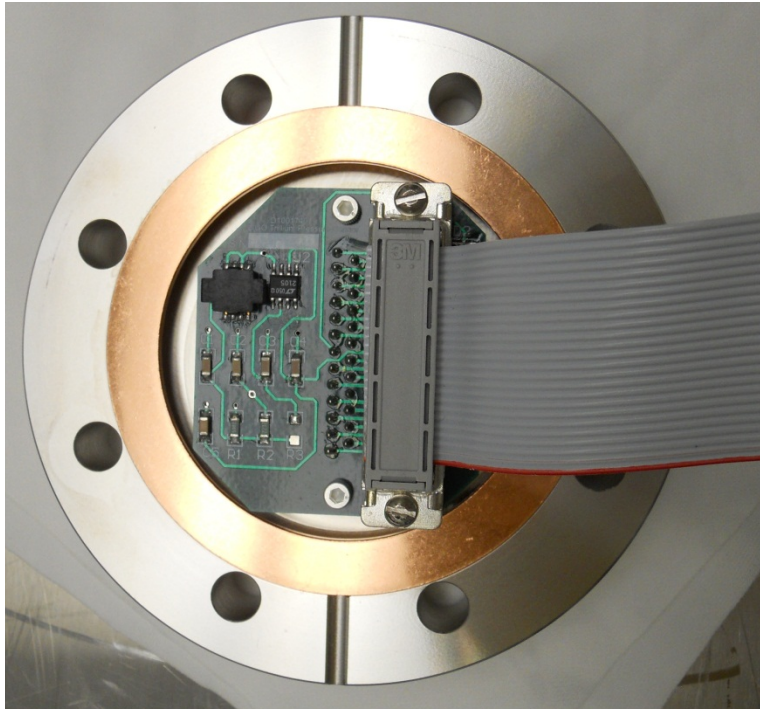

Figure 11: Cable and Copper Gasket mounted onto the Feed Thru

11. Attach Feed Thru end of cable to 4.5" Feed Thru DB25 with 4-40 x 0.5" long SHCS.

Hardware:

(2) 4-40 x 0.5" long SHCS

(2) 4-40 Washers

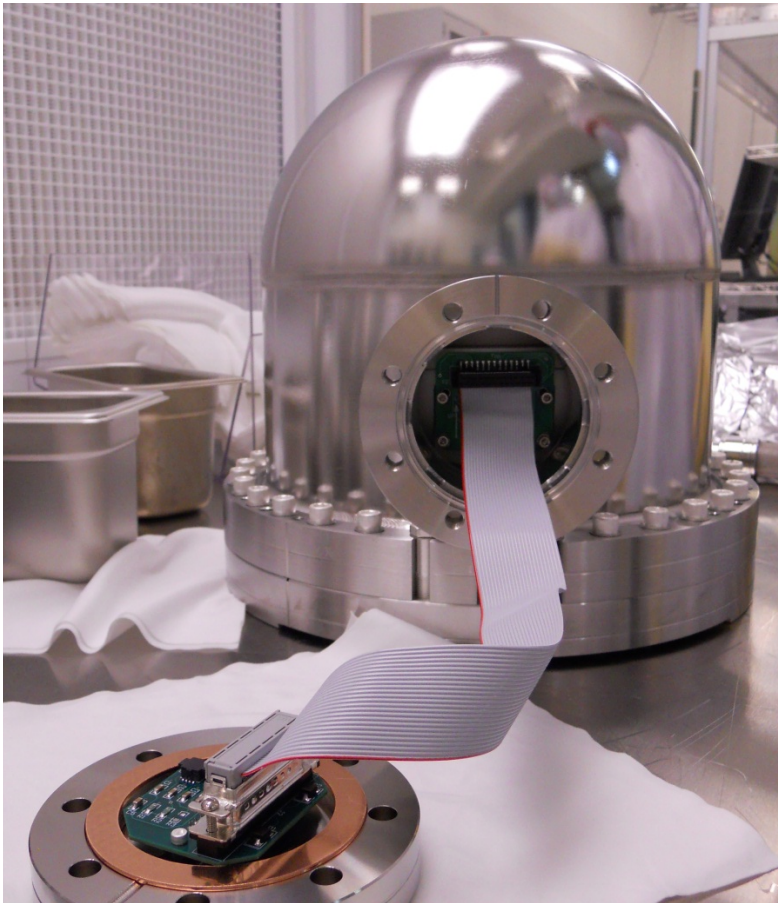

Figure 12: Trillium Pod Assembly with Cable bolted to the Feed Thru and ready to be filled with Neon and closed

12. Fill the Trillium Pod Chamber with Neon for about 2 Minutes.

13. Coil cable into Top Hat port, making sure not to twist it too hard and attach Feed Thru to Top Hat Port Flange with eight 5/16"-18 x 1.0" Ag Plated SHCS and eight 5/16" Vented Washers.

Hardware:

(8) 5/16"-24 x 1.0" Ag Plated SHCS

(8) 5/16" Vented Washers

14. As previously, it is recommended that one insert and tighten the first 4 bolts in a star-like fashion (not one at a time around the circumference) for alignment purposes. Then torque all the bolts incrementally, up to the final torque value **345 in.lbs**, using a circular clockwise pattern. [Once again, this torque value is higher than the Nor-Cal Spec.: 190 in.lbs, in order to make sure that the two flange faces are brought metal to metal]
15. Check that the flange faces are metal to metal.

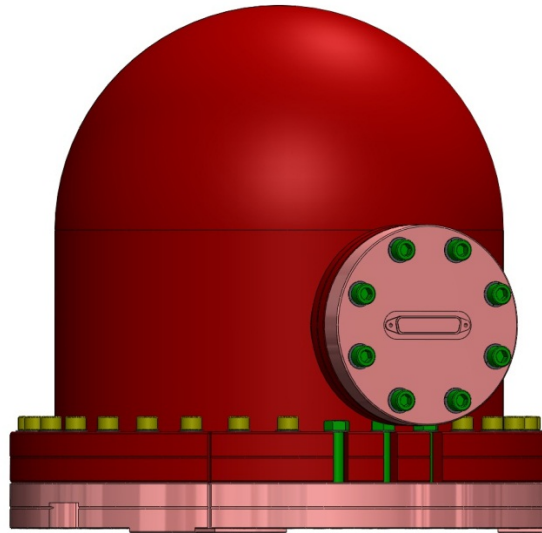

Figure 13: Complete Trillium Pod Assembly

16. The Trillium Pod Assembly is now complete and needs to be Leak Tested!