

- NOTES:
 1) ALL DIMENSIONS ARE IN INCHES
 2) SOME BSC TRAYS INTERFERE WITH SPOOL REMOVAL; MUST BE DIS-ASSEMBLED
 3) TRAY FOR ION PUMP HIGH VOLTAGE CABLES IS NOT SHOWN YET
 4) SEPARATE TRAY FOR VACUUM CONTROL AND MONITORING SYSTEM (VCMS) RACKS?
 5) CABLE TRAY SUPPORTS ARE NOT SHOWN YET
 6) CAPACITIVE POSITION SENSOR SATELLITE RACKS ARE NOT SHOWN YET (MUST BE WITHIN 1 METER OF FLANGE) – ON SMALL TABLE NEAR HAM CHAMBER & ON BSC CROSS-BEAM?
 7) PRECISE LOCATION OF H1 TCS CHILLER AND VCMS-R3 IN MECHANICAL ROOM TBD
 8) TRAY CIRCLING THE BSC CHAMBERS MUST BE OPEN WIRE TYPE WITH CUSTOM ATTACHMENT STRUCTURE TO CLAMP TO THE STIFFENING RING JUST BELOW THE FEEDTHROUGH PORTS
 9) ALL TRAY TO BE LADDER OR RAIL TYPE (EXCEPT CIRCLING THE BSC CHAMBERS) – SEE SHEET 2 FOR CABLE TRAY SIZE INFORMATION
 10) CUSTOM TRAY SUPPORTS NEEDED OVER HAM CHAMBERS
 11) CONDUITS FOR DC POWER DISTRIBUTION?
 12) HV TRAY FOR ION PUMPS NOT SHOWN

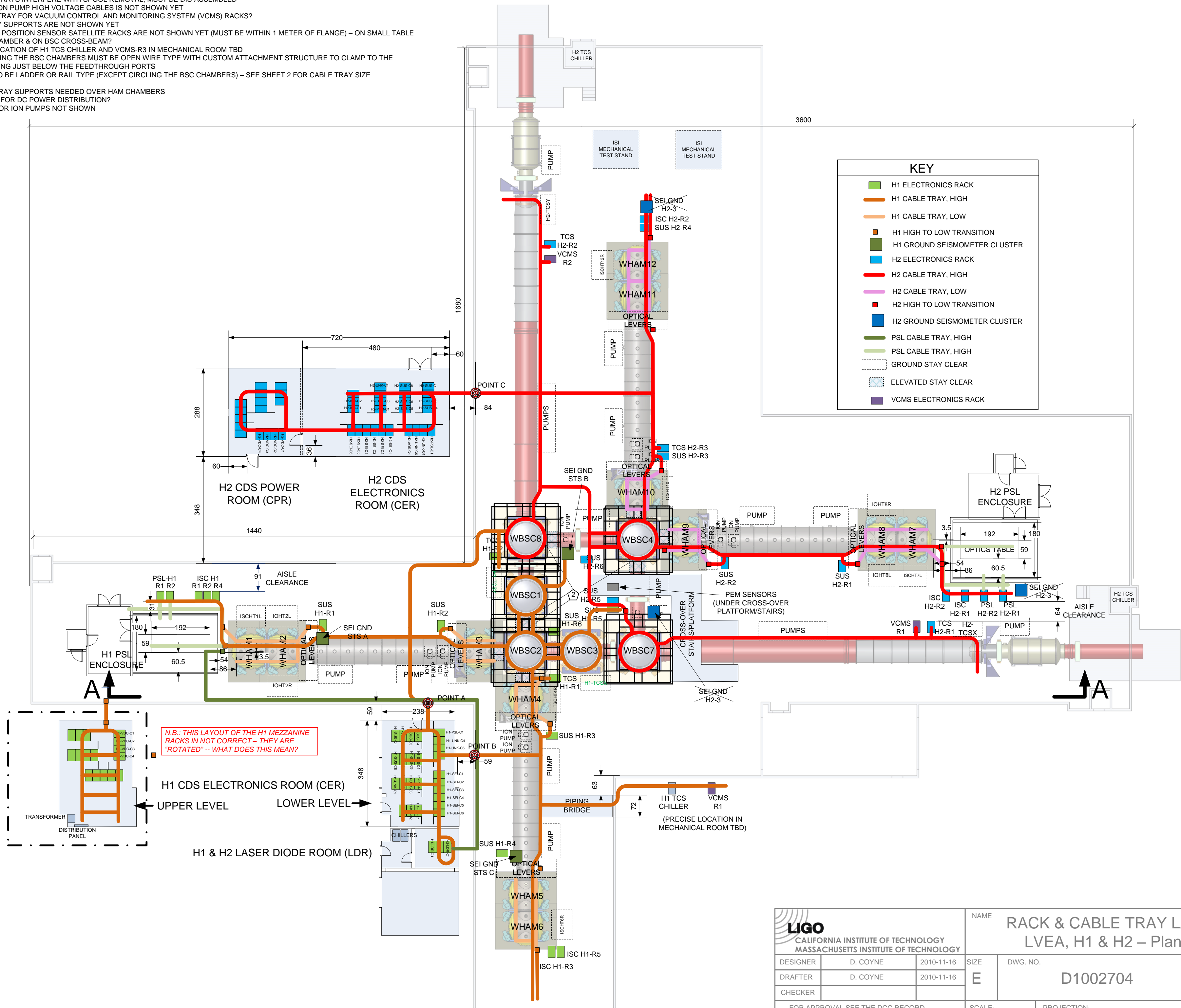

N.B.: THIS LAYOUT OF THE H1 MEZZANINE RACKS IS NOT CORRECT – THEY ARE "ROTATED" -- WHAT DOES THIS MEAN?

		NAME RACK & CABLE TRAY LAYOUT, LVEA, H1 & H2 – Plan View	
CALIFORNIA INSTITUTE OF TECHNOLOGY MASSACHUSETTS INSTITUTE OF TECHNOLOGY		DESIGNER D. COYNE	DATE 2010-11-16
DRAFTER D. COYNE	DATE 2010-11-16	SIZE E	DWG. NO. D1002704
CHECKER	SCALE:	PROJECTION:	REV V6
FOR APPROVAL SEE THE DCC RECORD		SHEET 1 OF 5	

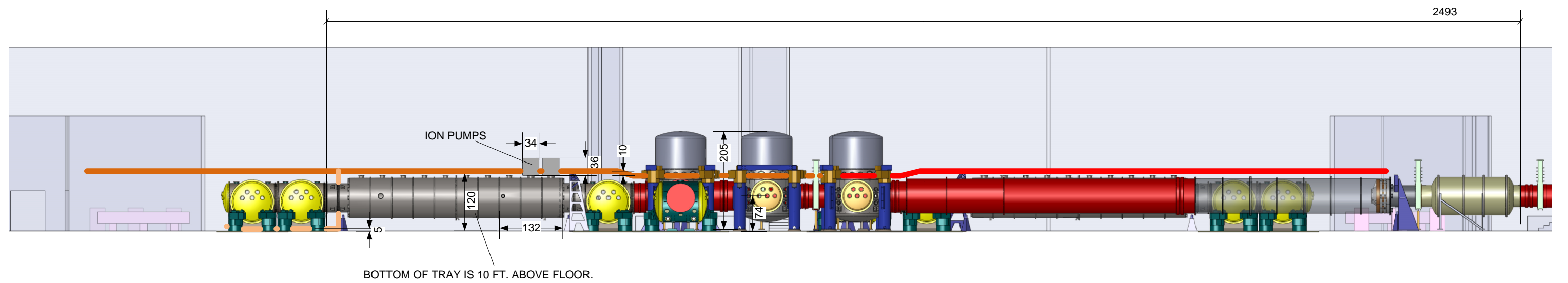

SECTION A-A

NOTE: CABLE TRAY IS ONLY SHOWN ALONG THE H1 A-ARM FOR CLARITY.

 LIGO CALIFORNIA INSTITUTE OF TECHNOLOGY MASSACHUSETTS INSTITUTE OF TECHNOLOGY			NAME RACK & CABLE TRAY LAYOUT, LVEA, H1 & H2 -- Elevations		
DESIGNER	D. COYNE	2010-11-16	SIZE	DWG. NO.	REV
DRAFTER	D. COYNE	2010-11-16	E	D1002704	V6
CHECKER					
FOR APPROVAL SEE THE DCC RECORD			SCALE:	PROJECTION:	SHEET 2 OF 5

- NOTES:
 1) ALL DIMENSIONS ARE IN INCHES
 2) SOME BSC TRAYS INTERFERE WITH SPOOL REMOVAL; MUST BE DIS-ASSEMBLED
 3) TRAY FOR ION PUMP HIGH VOLTAGE CABLES IS NOT SHOWN YET
 4) SEPARATE TRAY FOR VACUUM CONTROL AND MONITORING SYSTEM (VCMS) RACKS?
 5) CABLE TRAY SUPPORTS ARE NOT SHOWN YET
 6) CAPACITIVE POSITION SENSOR SATELLITE RACKS ARE NOT SHOWN YET (MUST BE WITHIN 1 METER OF FLANGE) – ON SMALL TABLE NEAR HAM CHAMBER & ON BSC CROSS-BEAM?
 7) PRECISE LOCATION OF H1 TCS CHILLER AND VCMS-R3 IN MECHANICAL ROOM TBD
 8) TRAY CIRCLING THE BSC CHAMBERS MUST BE OPEN WIRE TYPE WITH CUSTOM ATTACHMENT STRUCTURE TO CLAMP TO THE STIFFENING RING JUST BELOW THE FEEDTHROUGH PORTS
 9) ALL TRAY TO BE LADDER OR RAIL TYPE (EXCEPT CIRCLING THE BSC CHAMBERS) – SEE SHEET 2 FOR CABLE TRAY SIZE INFORMATION
 10) CUSTOM TRAY SUPPORTS NEEDED OVER HAM CHAMBERS
 11) CONDUITS FOR DC POWER DISTRIBUTION?
 12) HV TRAY FOR ION PUMPS NOT SHOWN

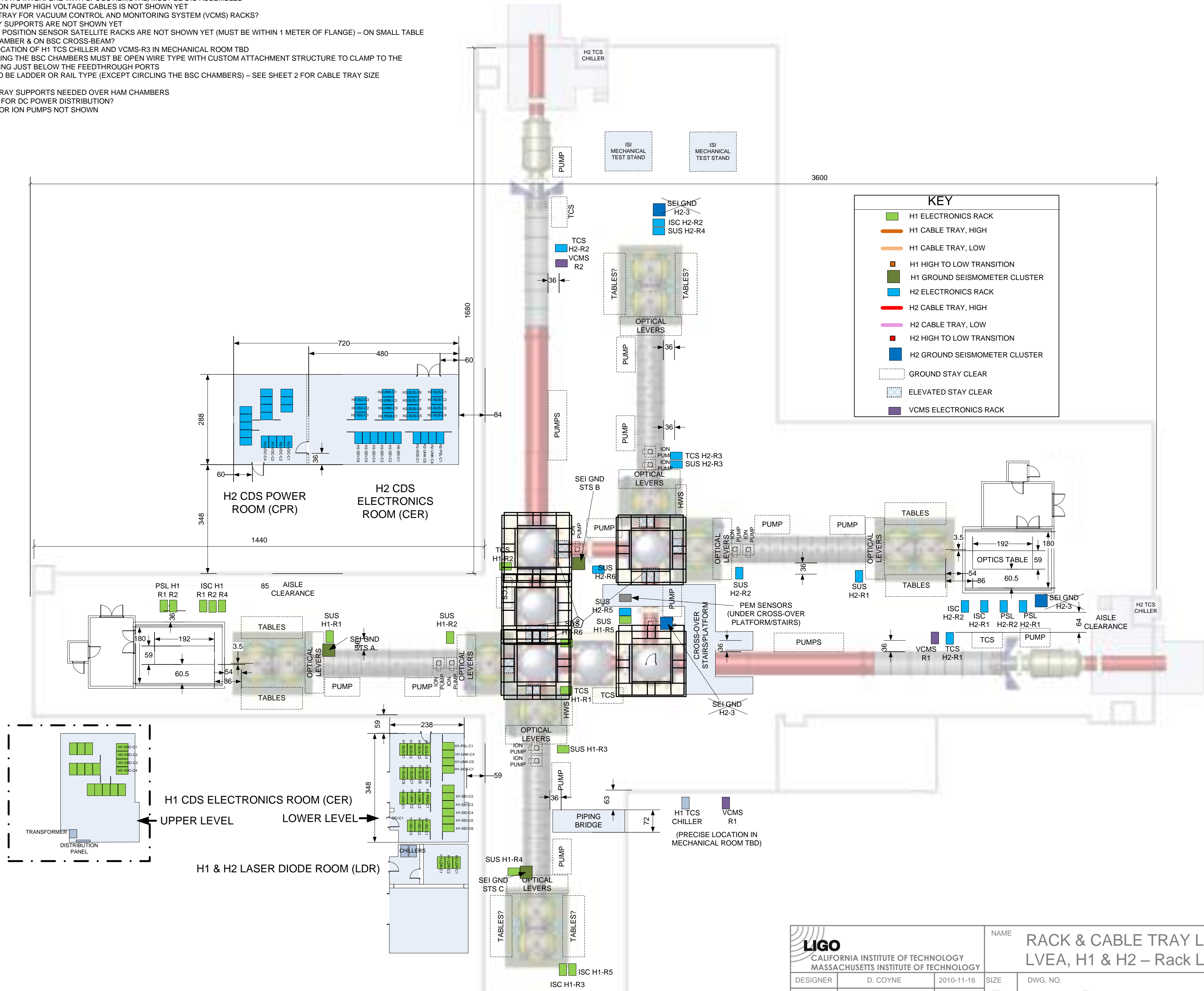

KEY

- H1 ELECTRONICS RACK
- H1 CABLE TRAY, HIGH
- H1 CABLE TRAY, LOW
- H1 HIGH TO LOW TRANSITION
- H1 GROUND SEISMOMETER CLUSTER
- H2 ELECTRONICS RACK
- H2 CABLE TRAY, HIGH
- H2 CABLE TRAY, LOW
- H2 HIGH TO LOW TRANSITION
- H2 GROUND SEISMOMETER CLUSTER
- GROUND STAY CLEAR
- ELEVATED STAY CLEAR
- VCMS ELECTRONICS RACK

 CALIFORNIA INSTITUTE OF TECHNOLOGY MASSACHUSETTS INSTITUTE OF TECHNOLOGY			NAME		RACK & CABLE TRAY LAYOUT, LVEA, H1 & H2 – Rack Locations	
			DESIGNER	D. COYNE	2010-11-16	SIZE
DRAFTER	D. COYNE	2010-11-16	E	D1002704		V6
CHECKER						
FOR APPROVAL SEE THE DCC RECORD			SCALE:	PROJECTION:	SHEET 3 OF 5	

- NOTES:
 1) ALL DIMENSIONS ARE IN INCHES
 2) SOME BSC TRAYS INTERFERE WITH SPOOL REMOVAL; MUST BE DIS-ASSEMBLED
 3) TRAY FOR ION PUMP HIGH VOLTAGE CABLES IS NOT SHOWN YET
 4) SEPARATE TRAY FOR VACUUM CONTROL AND MONITORING SYSTEM (VCMS) RACKS?
 5) CABLE TRAY SUPPORTS ARE NOT SHOWN YET
 6) CAPACITIVE POSITION SENSOR SATELLITE RACKS ARE NOT SHOWN YET (MUST BE WITHIN 1 METER OF FLANGE) – ON SMALL TABLE NEAR HAM CHAMBER & ON BSC CROSS-BEAM?
 7) PRECISE LOCATION OF H1 TCS CHILLER AND VCMS-R3 IN MECHANICAL ROOM TBD
 8) TRAY CIRCLING THE BSC CHAMBERS MUST BE OPEN WIRE TYPE WITH CUSTOM ATTACHMENT STRUCTURE TO CLAMP TO THE STIFFENING RING JUST BELOW THE FEEDTHROUGH PORTS
 9) ALL TRAY TO BE LADDER OR RAIL TYPE (EXCEPT CIRCLING THE BSC CHAMBERS) – SEE SHEET 2 FOR CABLE TRAY SIZE INFORMATION
 10) CUSTOM TRAY SUPPORTS NEEDED OVER HAM CHAMBERS
 11) CONDUITS FOR DC POWER DISTRIBUTION?
 12) HV TRAY FOR ION PUMPS NOT SHOWN

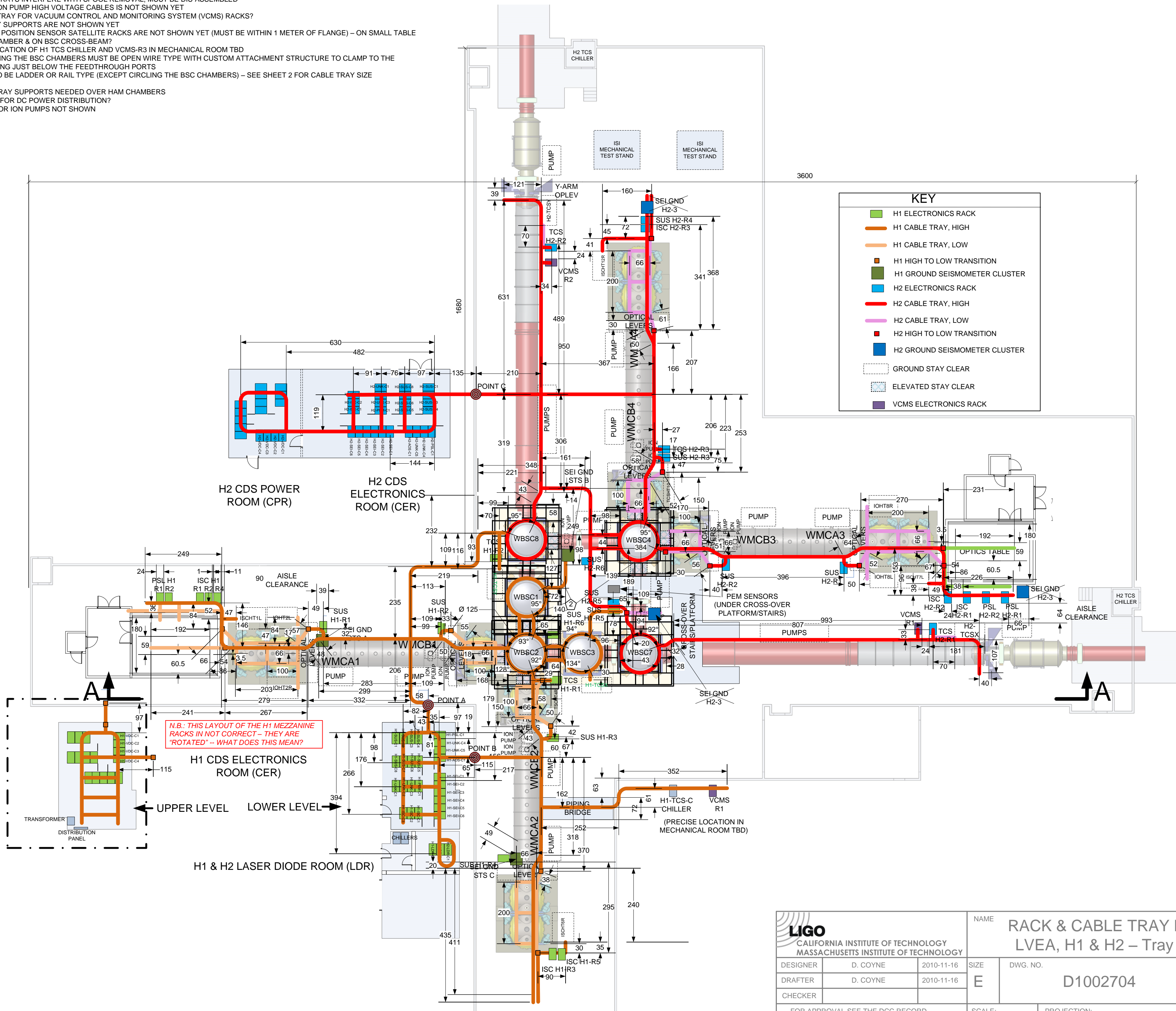

N.B.: THIS LAYOUT OF THE H1 MEZZANINE RACKS IS NOT CORRECT – THEY ARE "ROTATED" – WHAT DOES THIS MEAN?

			NAME: RACK & CABLE TRAY LAYOUT, LVEA, H1 & H2 – Tray Lengths		
CALIFORNIA INSTITUTE OF TECHNOLOGY MASSACHUSETTS INSTITUTE OF TECHNOLOGY			DESIGNER: D. COYNE 2010-11-16	SIZE: E	DWG. NO.: D1002704
DRAFTER: D. COYNE 2010-11-16	CHECKER:	FOR APPROVAL SEE THE DCC RECORD	SCALE:	PROJECTION:	REV: V6
SHEET 4 OF 5					

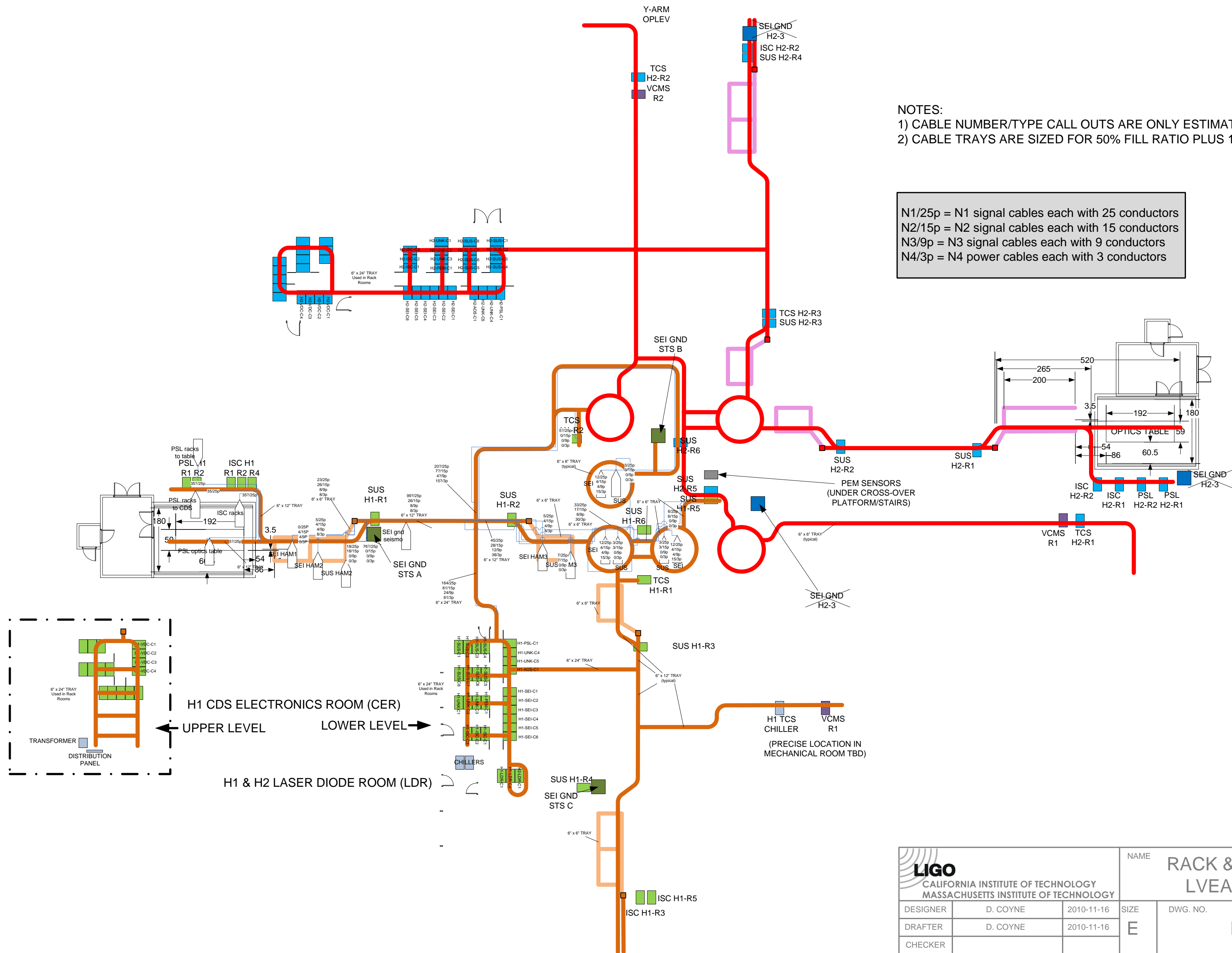

NOTES:
 1) CABLE NUMBER/TYPE CALL OUTS ARE ONLY ESTIMATES.
 2) CABLE TRAYS ARE SIZED FOR 50% FILL RATIO PLUS 100% SPARE CAPACITY

N1/25p = N1 signal cables each with 25 conductors
 N2/15p = N2 signal cables each with 15 conductors
 N3/9p = N3 signal cables each with 9 conductors
 N4/3p = N4 power cables each with 3 conductors

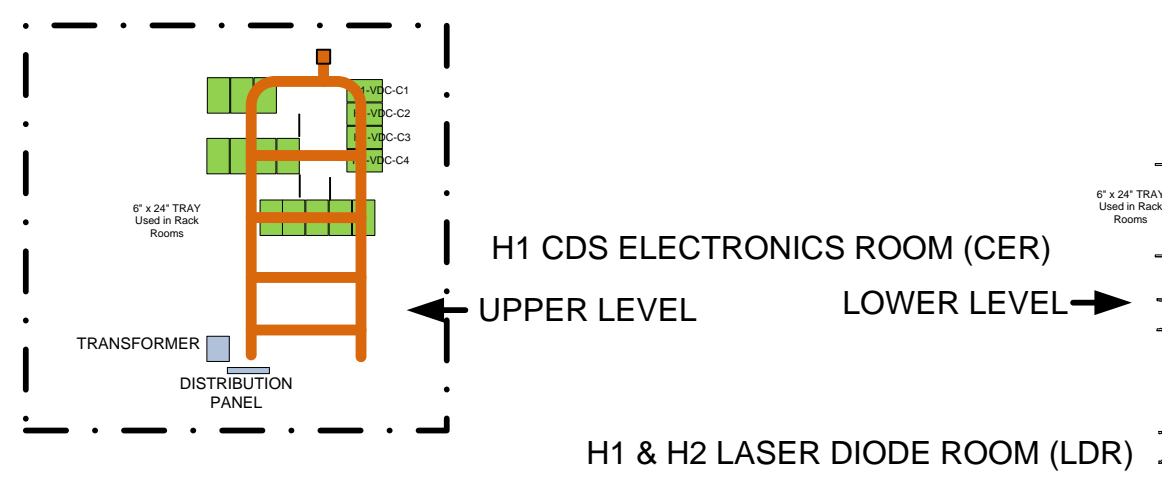
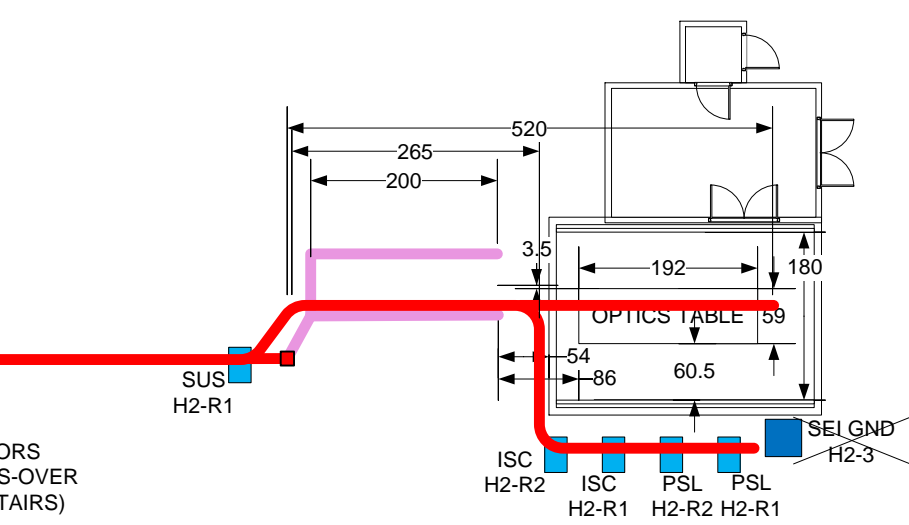

 CALIFORNIA INSTITUTE OF TECHNOLOGY MASSACHUSETTS INSTITUTE OF TECHNOLOGY			NAME RACK & CABLE TRAY LAYOUT, LVEA, H1 & H2 – Tray Sizes		
DESIGNER	D. COYNE	2010-11-16	SIZE	DWG. NO.	REV
DRAFTER	D. COYNE	2010-11-16	E	D1002704	V6
CHECKER					
FOR APPROVAL SEE THE DCC RECORD			SCALE:	PROJECTION:	SHEET 5 OF 5