

NOTES CONTINUED:  
 1. APPROXIMATE WEIGHT = 123.5 LB.

REV.	DATE	DCN #	DRAWING TREE #
v1	19 MAY 2011	E1000822-v1	-
v2	30 JUN 2011	E1000822-v2	-
-	-	-	-

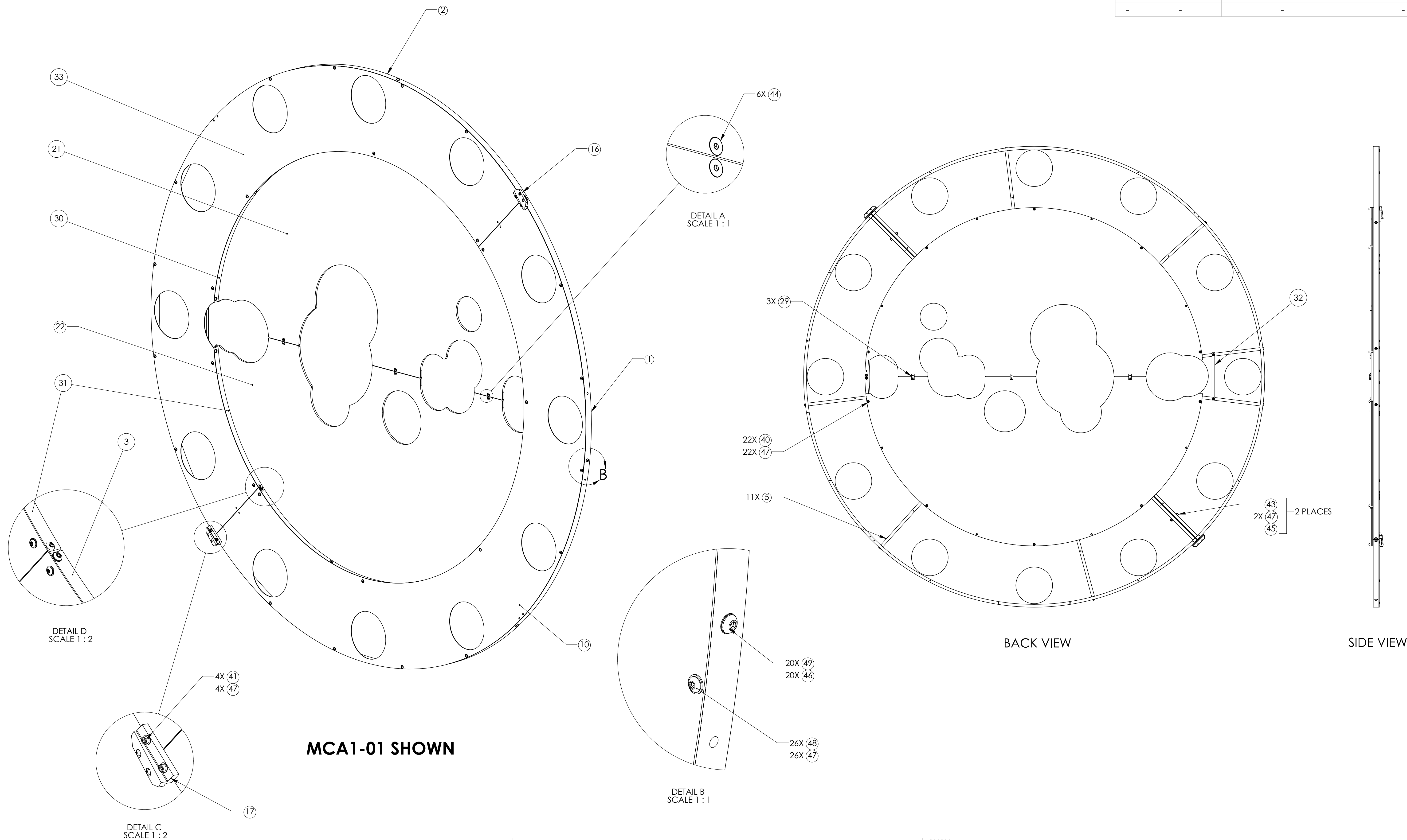

NOTES AND TOLERANCES: (UNLESS OTHERWISE SPECIFIED)				LIGO CALIFORNIA INSTITUTE OF TECHNOLOGY MASSACHUSETTS INSTITUTE OF TECHNOLOGY		PART NAME	
DIMENSIONS ARE IN INCHES				SYSTEM		MODE CLEANER TUBE BAFFLE ASSY	
TOLERANCES: .XX ± .03 .XXX ± .010				ADVANCED LIGO		SUB-SYSTEM	
ANGULAR ± 1.0°				FINISH		AOS	
MATERIAL				NEXT ASSY		DESIGNER	
N/A				N/A μinch		TQ. NGUYEN 8 NOV 2010	
				D1000774		SIZE DWG. NO.	
						D	
						D1002864	
						REV.	
						v1	
						SCALE: 1:12 PROJECTION:	
						SHEET 1 OF 9	

D1002864.dwg; Mode\_Cleaner\_Tube\_Baffle\_Frame Assy; PART PDM REV: X:072; DRAWING PDM REV: X:034

NOTES CONTINUED:  
 1. APPROXIMATE WEIGHT = 117.0 LB.

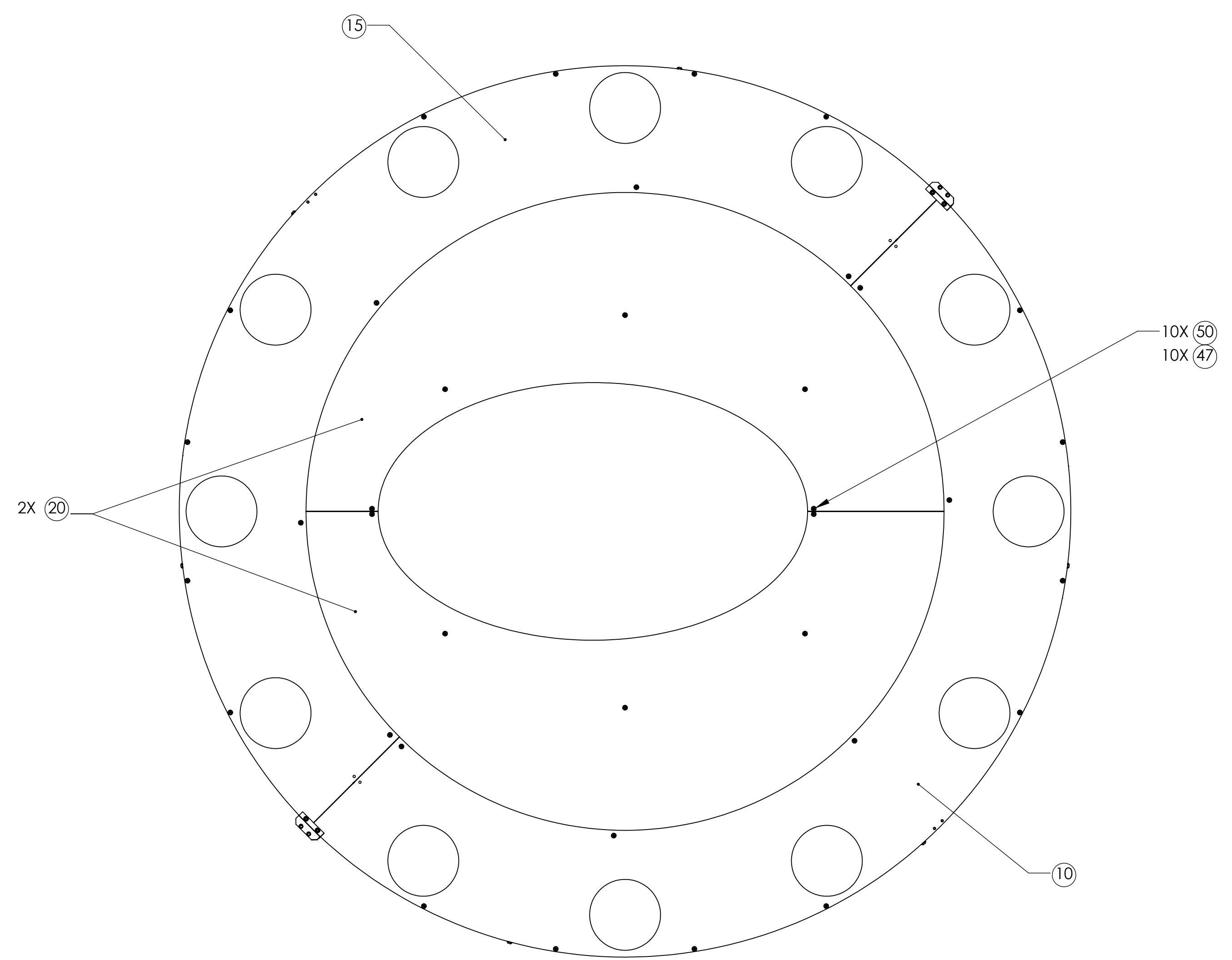

FRONT VIEW  
**MCA2-02 SHOWN**

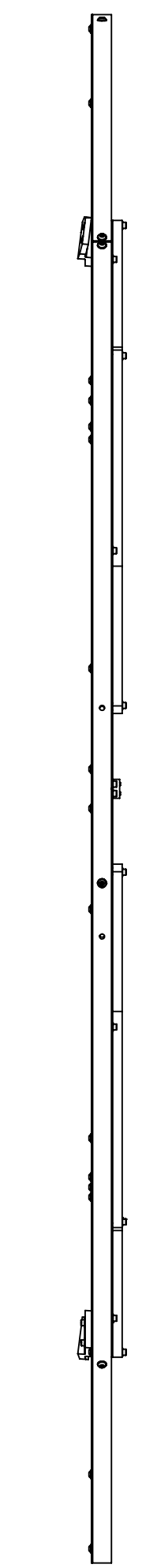

SIDE VIEW

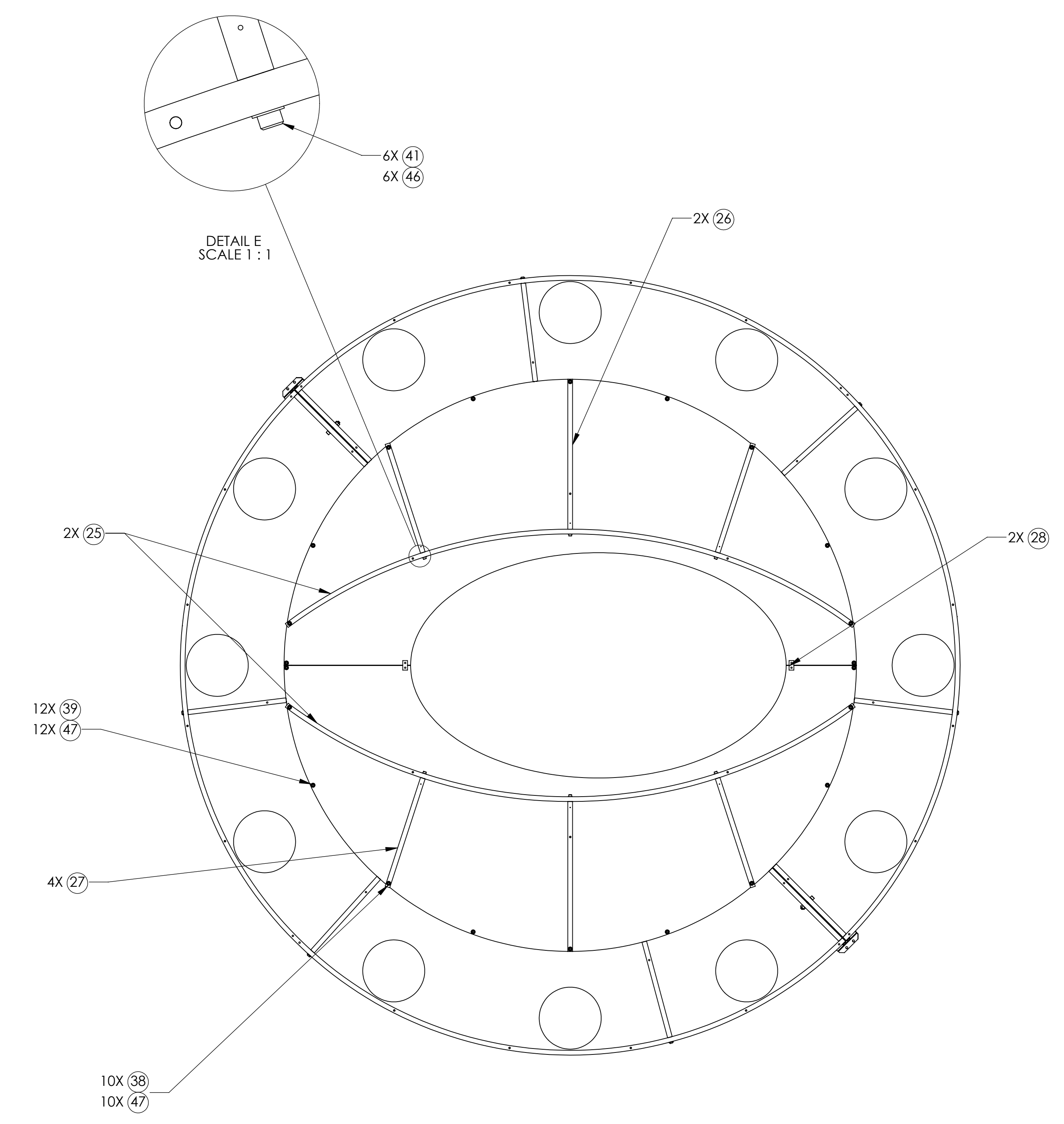

BACK VIEW

CALIFORNIA INSTITUTE OF TECHNOLOGY MASSACHUSETTS INSTITUTE OF TECHNOLOGY		REV.
SIZE	DWG. NO.	REV.
D	D1002864	v1
SCALE: 1:8	PROJECTION:	SHEET 2 OF 9

D:\002864.dwg; C:\Users\jcl...; Part PDM REV: X:072; DRAWING PDM REV: X:034

NOTES CONTINUED:  
1. APPROXIMATE WEIGHT = 125.0 LB.

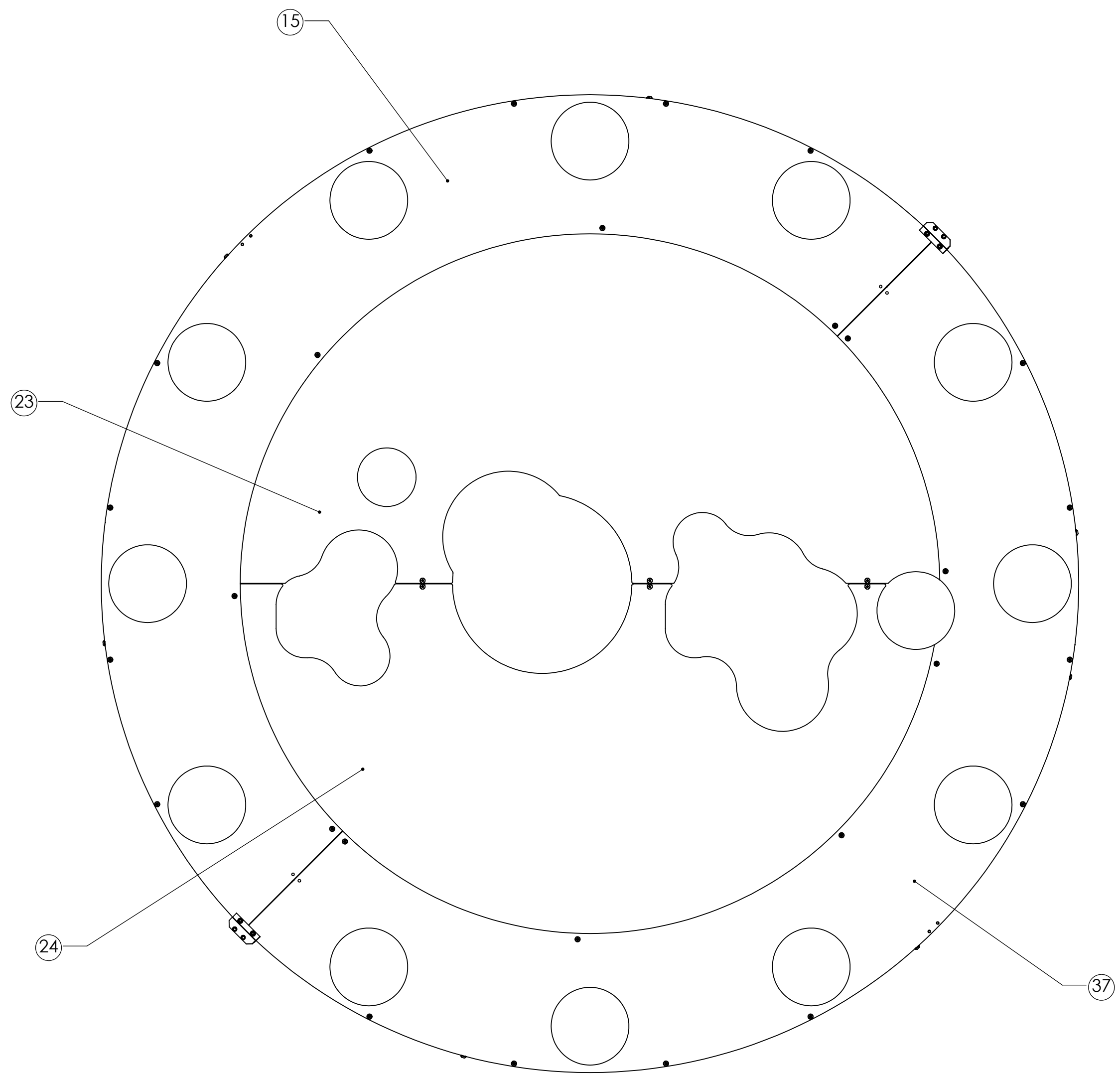

FRONT VIEW  
**MCA3-03 SHOWN**

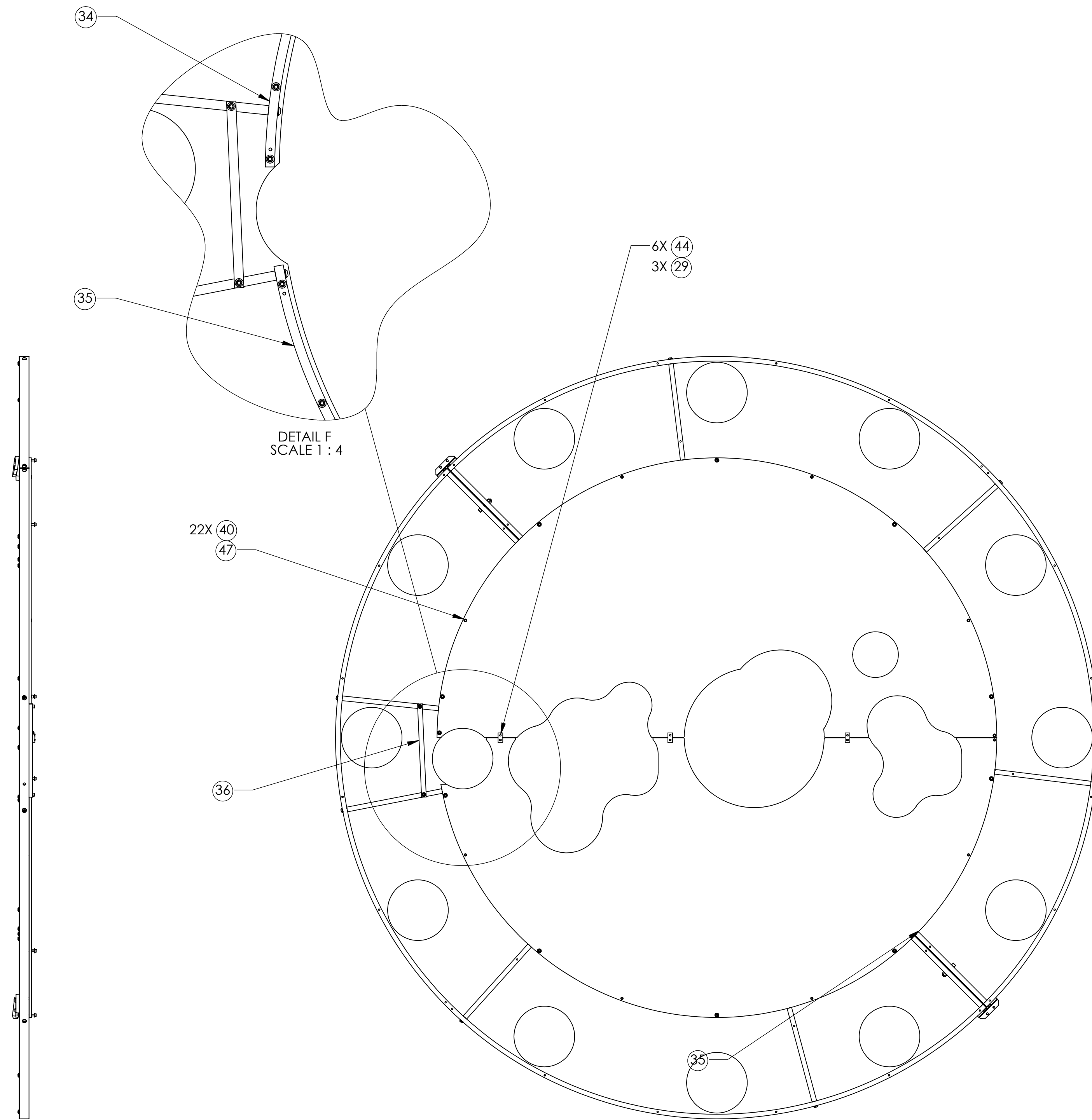

SIDE VIEW

BACK VIEW

<b>LIGO</b> CALIFORNIA INSTITUTE OF TECHNOLOGY MASSACHUSETTS INSTITUTE OF TECHNOLOGY		REV.
SIZE DWG. NO.	<b>D1002864</b>	v1
SCALE: 1:8	PROJECTION:	SHEET 3 OF 9

D:\002864.d\GO\_Mods\Cleane\_Tube\_Baffle\_Frame Assy\_PART PDM\_REV: X:072 DRAWING PDM\_REV: X:034

NOTES CONTINUED:  
1. APPROXIMATE WEIGHT = 117.0 LB.

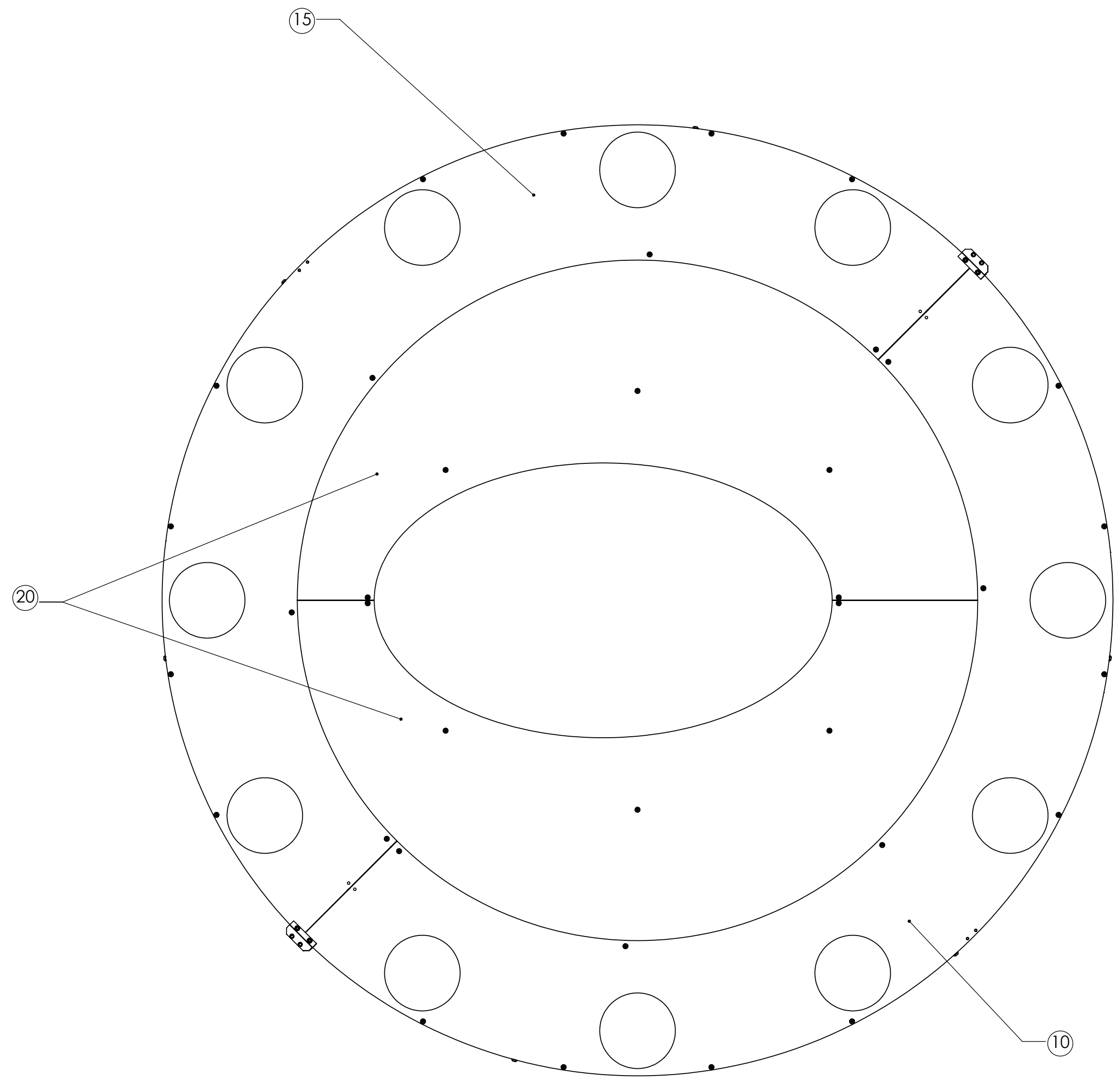

FRONT VIEW  
**MCA4-04 SHOWN**

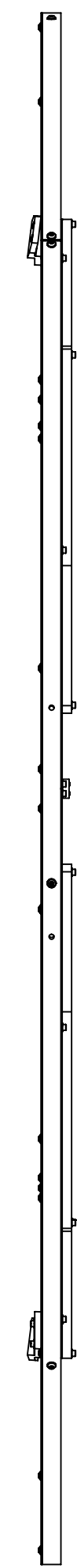

SIDE VIEW

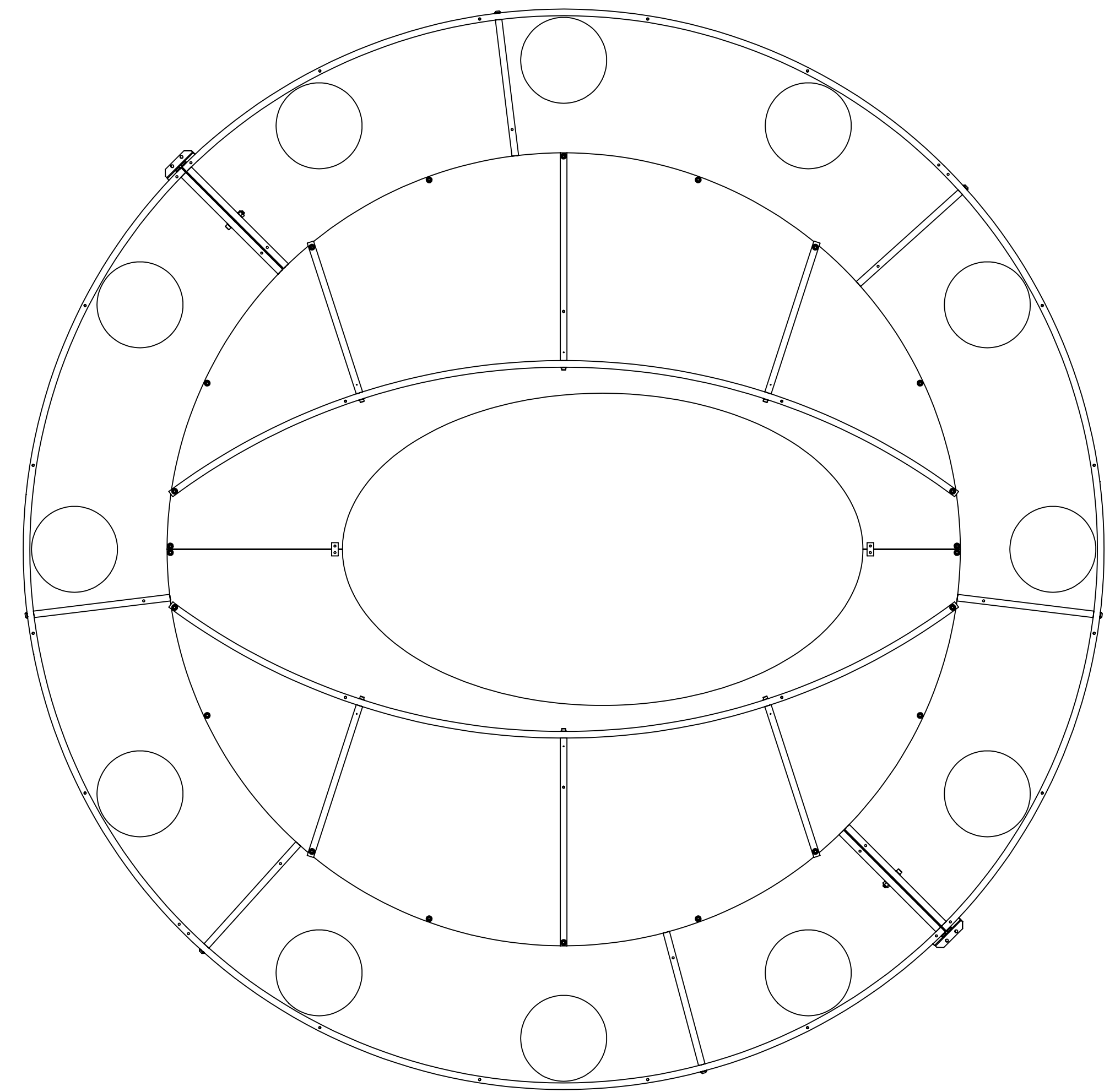

BACK VIEW

 CALIFORNIA INSTITUTE OF TECHNOLOGY MASSACHUSETTS INSTITUTE OF TECHNOLOGY		
SIZE	DWG. NO.	REV.
D	D1002864	v1
SCALE: 1:8	PROJECTION:	SHEET 4 OF 9

D:\002864\_d\lgo\_models\Cleane\_Tube\_Baffle\_Frame Assy\_PART PDM\_REV: X:072 DRAWING PDM\_REV: X:034

NOTES CONTINUED:  
1. APPROXIMATE WEIGHT = 110.5 LB.

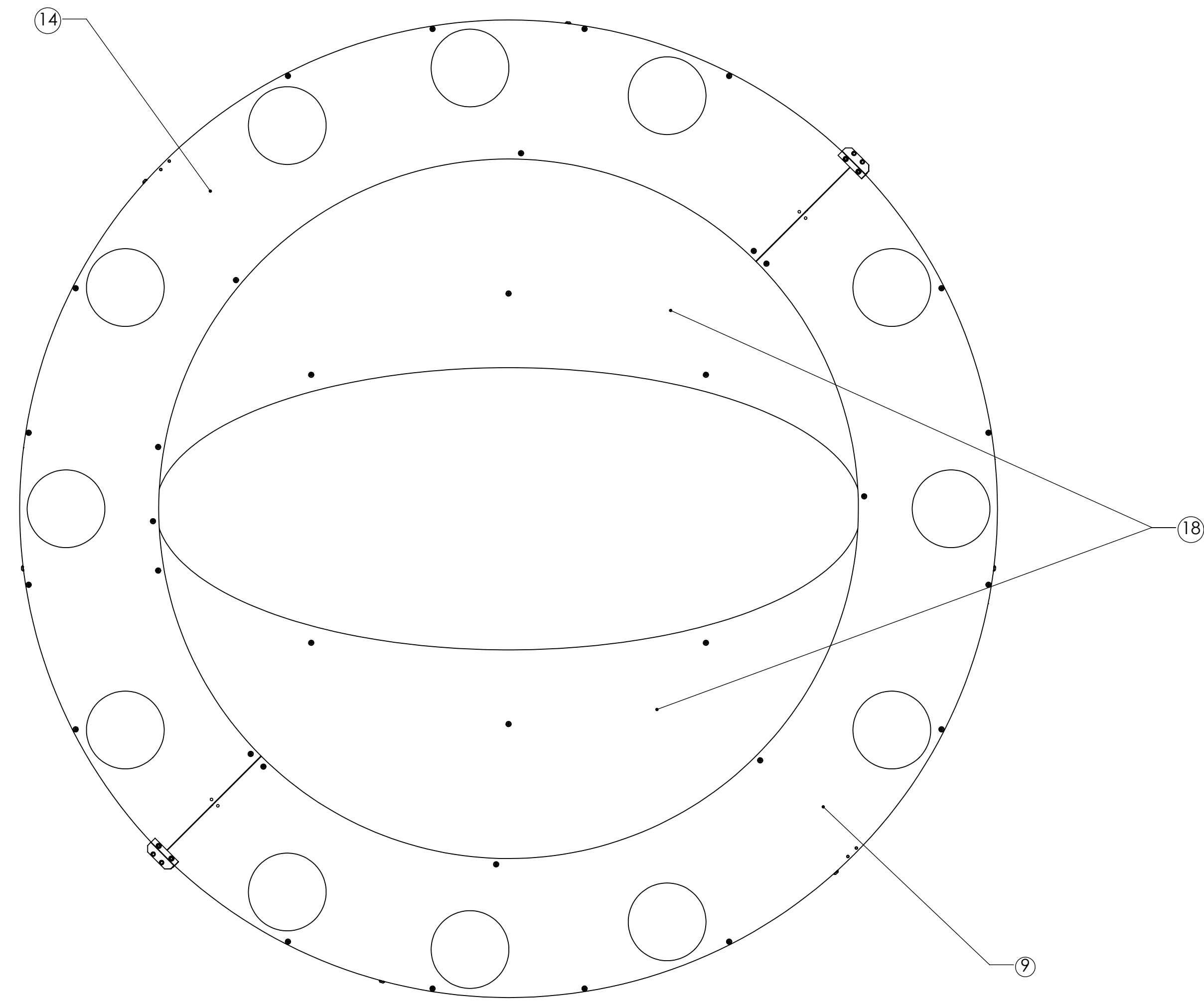

FRONT VIEW  
**MCB1-05 SHOWN**

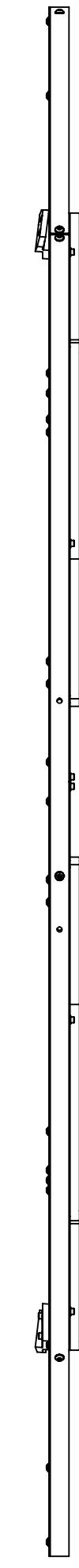

SIDE VIEW

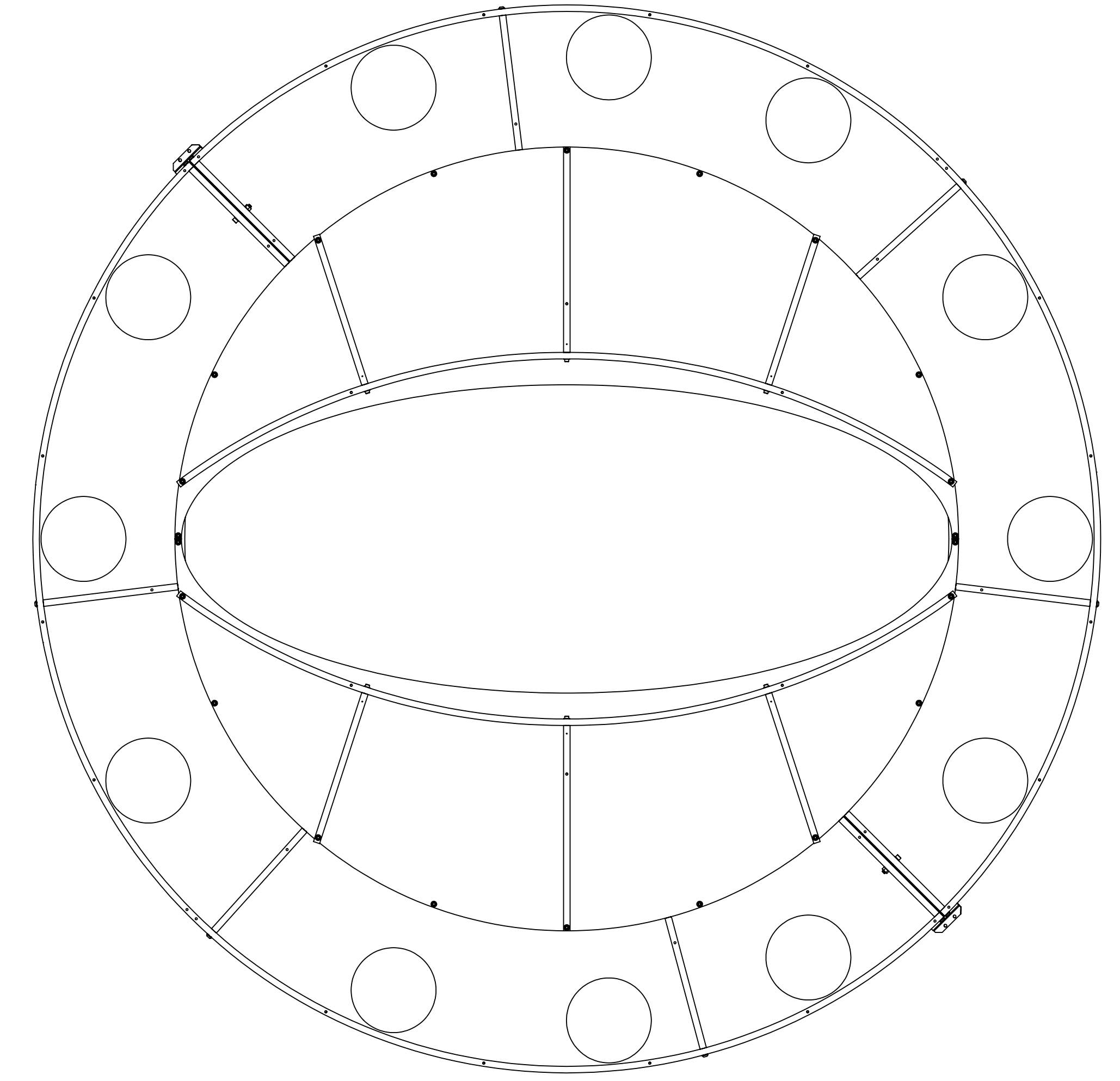

BACK VIEW

 CALIFORNIA INSTITUTE OF TECHNOLOGY MASSACHUSETTS INSTITUTE OF TECHNOLOGY		REV.
SIZE DWG. NO.	D1002864	v1
SCALE: 1:8	PROJECTION:	SHEET 5 OF 9

D:\002864.d\lgo\_models\Cleane\_Tube\_Baffle\_Frame Assy\_PART PDM\_REV: X:072 DRAWING PDM\_REV: X:034

NOTES CONTINUED:  
1. APPROXIMATE WEIGHT = 113.5 LB.

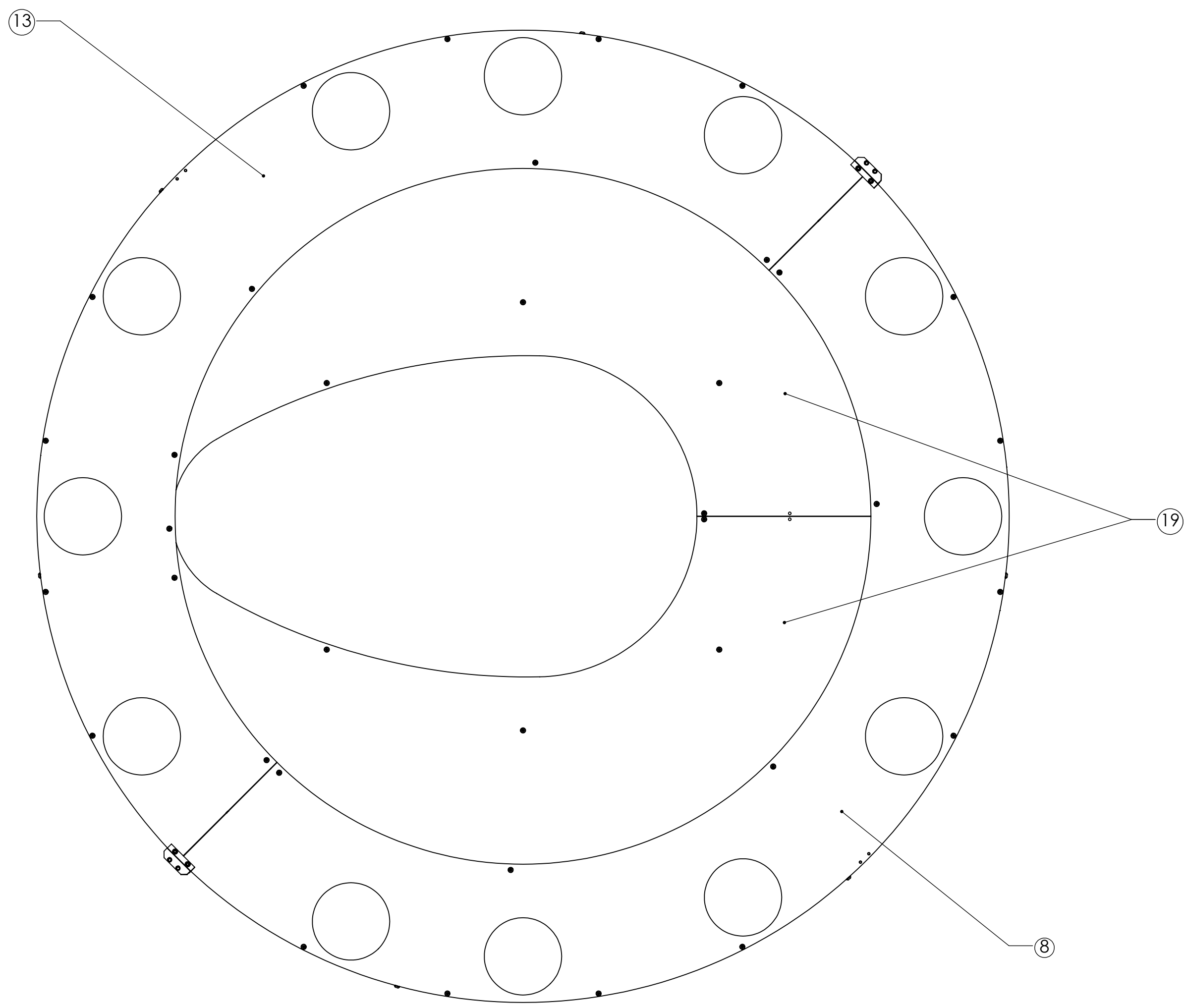

FRONT VIEW  
**MCB2-06 SHOWN**

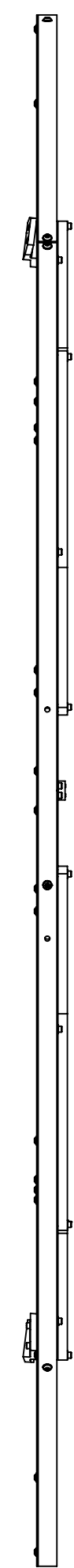

SIDE VIEW

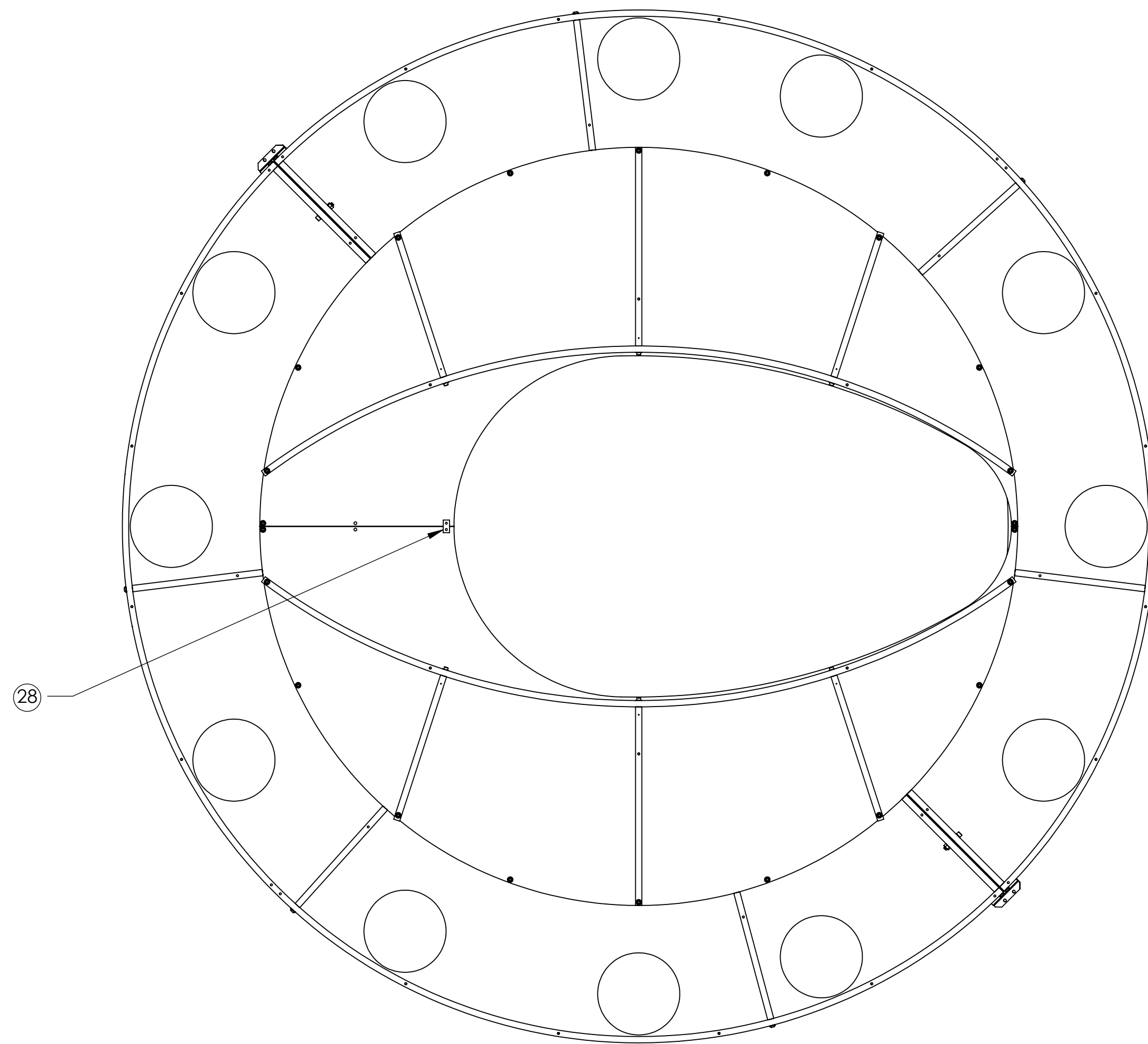

BACK VIEW

 CALIFORNIA INSTITUTE OF TECHNOLOGY MASSACHUSETTS INSTITUTE OF TECHNOLOGY		
SIZE	DWG. NO.	REV.
D	D1002864	v1
SCALE: 1:8	PROJECTION:	SHEET 6 OF 9

D:\002864\_d\lgo\_models\Cleane\_Tube\_Baffle\_Frame Assy\_PART PDM\_REV: X:072 DRAWING PDM\_REV: X:034

NOTES CONTINUED:  
1. APPROXIMATE WEIGHT = 110.5 LB.

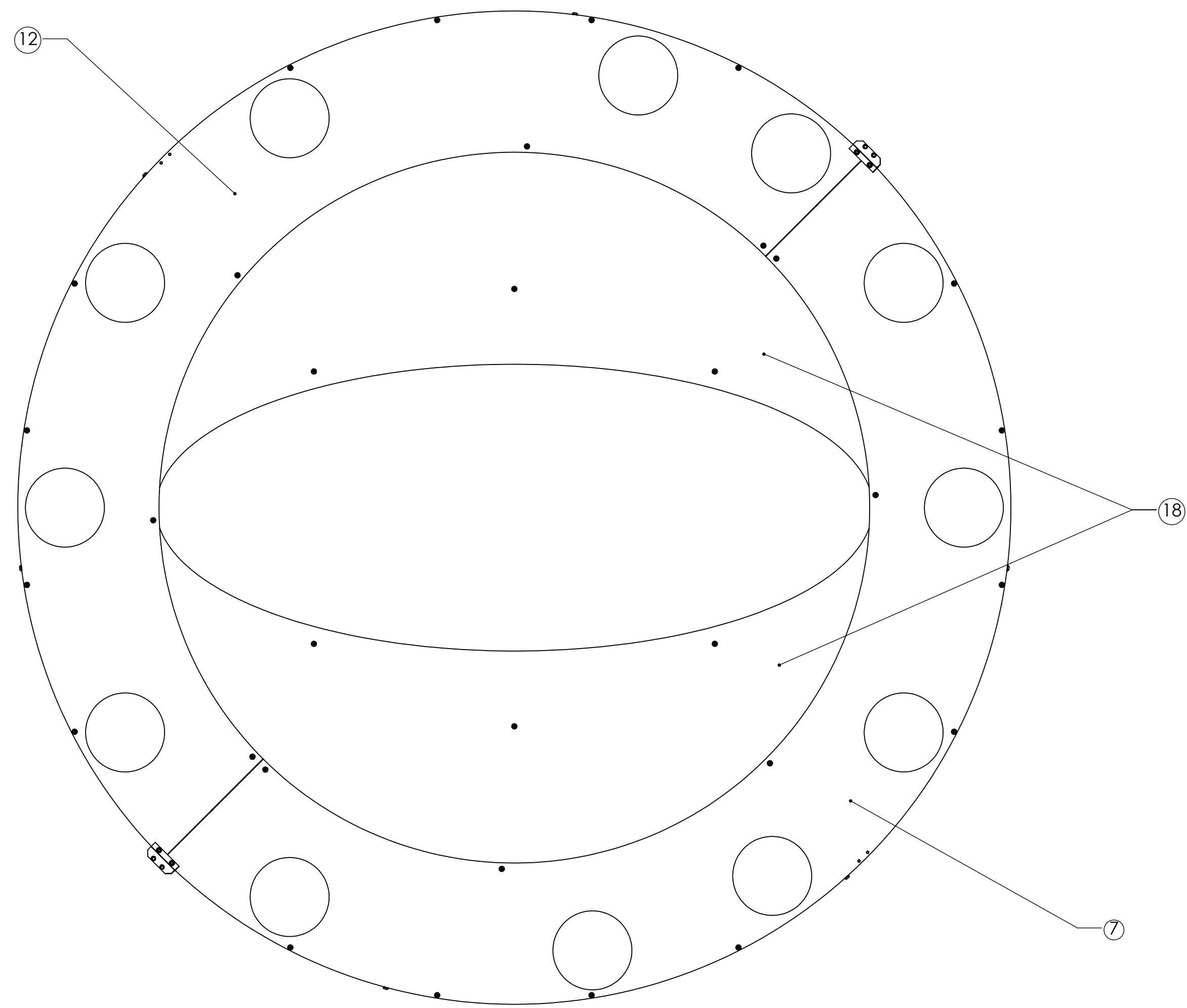

FRONT VIEW  
**MCB3-07 SHOWN**

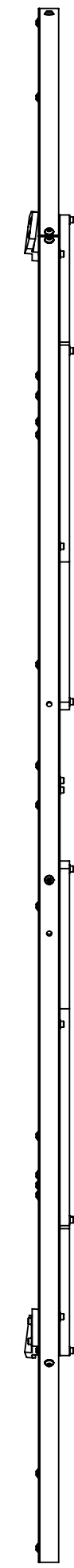

SIDE VIEW

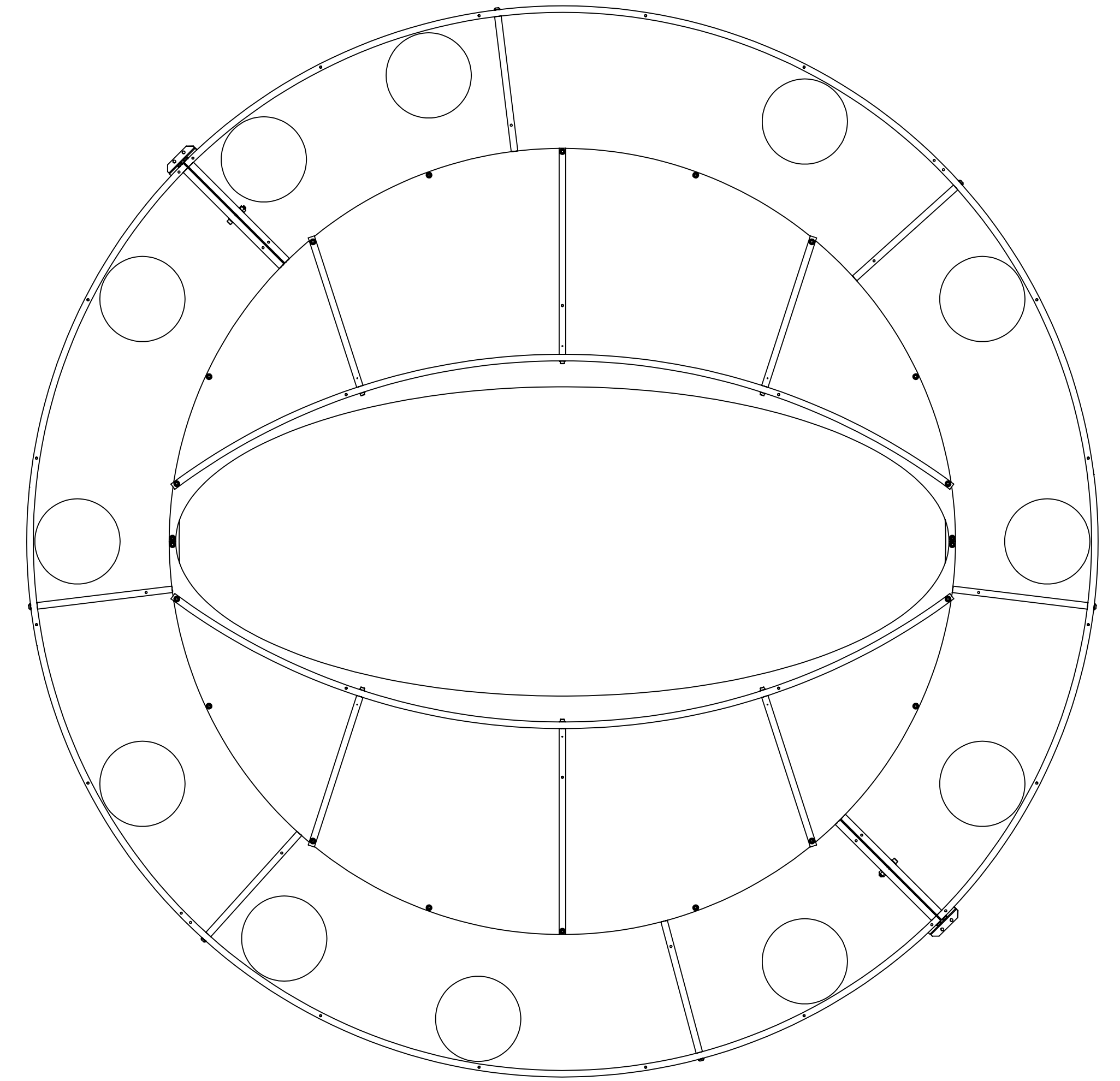

BACK VIEW

 CALIFORNIA INSTITUTE OF TECHNOLOGY MASSACHUSETTS INSTITUTE OF TECHNOLOGY		
SIZE	DWG. NO.	REV.
D	D1002864	v1
SCALE: 1:8	PROJECTION:	SHEET 7 OF 9

D:\002864\_d\UGO\_Models\Cleane\_Tube\_Baffle\_Frame Assy\_PART PDM\_REV: X:072 DRAWING PDM\_REV: X:034

NOTES CONTINUED:  
1. APPROXIMATE WEIGHT = 113.5 LB.

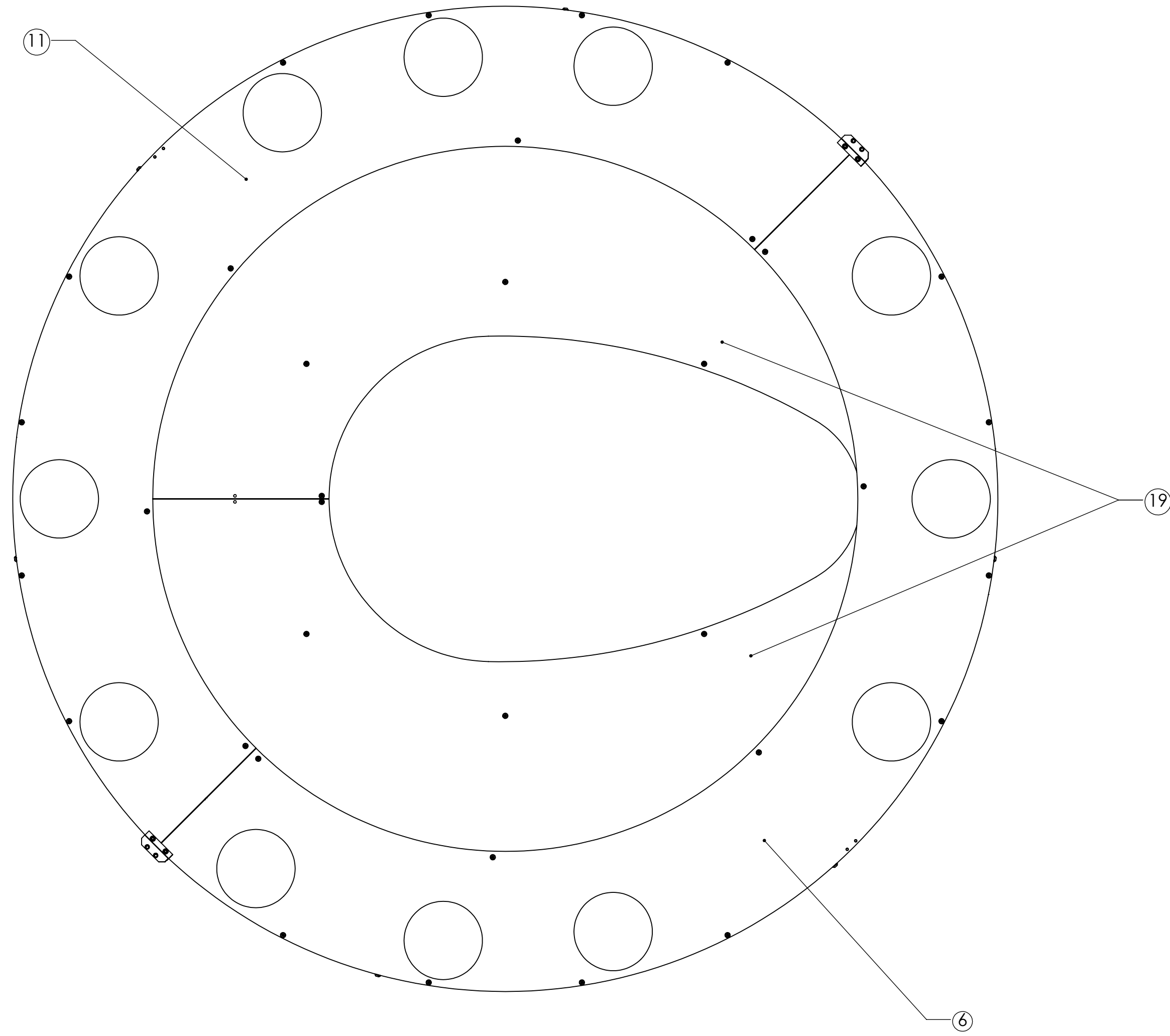

FRONT VIEW  
**MCB4-08 SHOWN**



SIDE VIEW

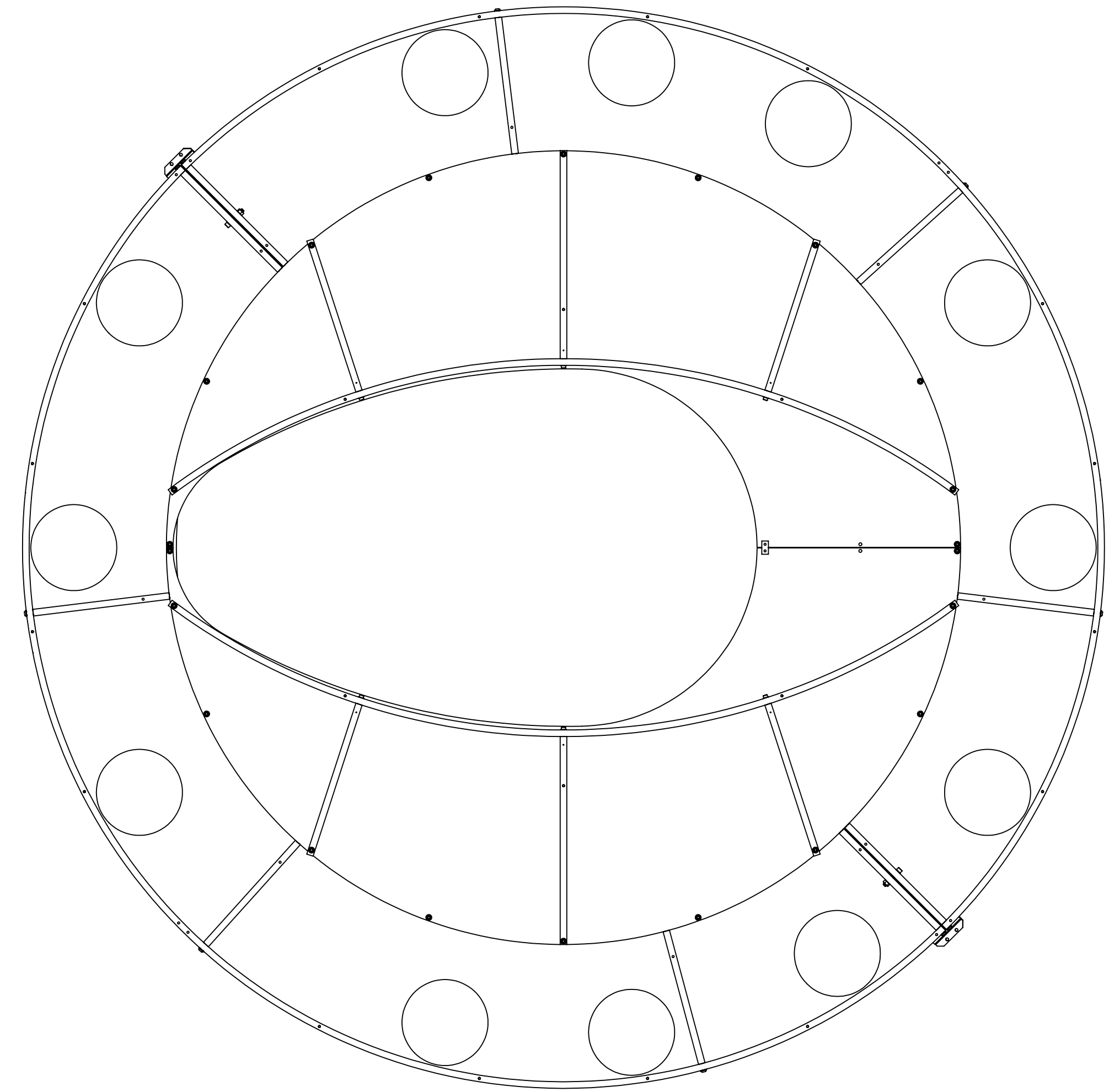

BACK VIEW

D:\002864\_d\lgo\_models\Cleane\_Tube\_Baffle\_Frame Assy\_PART PDM\_REV: X:072 DRAWING PDM\_REV: X:034



**PARTS LIST FOR D1002864 MODE CLEANER TUBE BAFFLE ASSEMBLY**

8	6	8	6	10	0	10	0	50	BU-1006-NA	BUTTON HEAD SOCKET CAP SCREW, 10-32, 5/8" L	Ag-PLATED 18-8 SSSL
20	20	20	20	20	22	20	22	49	BU-2016-N	BUTTON HEAD SOCKET HEAD CAP SCREW, 1/4-20 x 1" L	18-8 SSSL
26	26	26	26	26	27	26	27	48	BU-1006-N	BUTTON HEAD SOCKET CAP SCREW, #10-32 X 5/8" L	18-8 SSSL
68	66	68	66	68	53	68	50	47	WF-10	WASHER, #10 SCREW SIZE	18-8 SSSL
24	24	24	24	24	26	24	26	46	WF-25	WASHER, 1/4 SCREW SIZE	18-8 SSSL
2	2	2	2	2	2	2	2	45	N-2520	HEX NUT, 1/4-20	18-8 SSSL
0	0	0	0	0	6	0	6	44	FA-1010-N	SCREW, FLAT HEAD SOCKET CAP, 10-32 X 5/8" L	Ag-PLATED 18-8 SSSL
2	2	2	2	2	2	2	2	43	C-2024-N	SCREW, SOCKET HEAD CAP, 1/4-20 X 1-1/2" L	18-8 SSSL
6	6	6	6	6	0	6	0	42	C-1014-NA	SCREW, SOCKET HEAD CAP, #10-32 X 7/8" L	Ag-PLATED 18-8 SSSL
4	4	4	4	4	4	4	4	41	C-1012-N	SCREW, SOCKET HEAD CAP, #10-32 X 3/4" L	18-8 SSSL
0	0	0	0	0	23	0	20	40	C-1010-N	CREW, SOCKET HEAD CAP, #10-32 X 5/8" L	18-8 SSSL
12	12	12	12	12	0	12	0	39	C-1008-N	SCREW, SOCKET HEAD CAP, #10-32 X 1/2" L	18-8 SSSL
10	10	10	10	10	0	10	0	38	C-1016-N	SCREW, SOCKET HEAD CAP, #10-32 X 1" L	18-8 SSSL
0	0	0	0	0	1	0	0	37	D1101152	TUBE BAFFLE PLATE_LOWER-MCA3	18GA A424 TYPE 1 STEEL
0	0	0	0	0	1	0	0	36	D1101160	RECT BRACE, MCA3	6061-T6 Al
0	0	0	0	0	1	0	0	35	D1100350	INNER LOWER RIGHT BRACE, MCA3	6061-T6 Al
0	0	0	0	0	1	0	0	34	D1100312	INNER UPPER RIGHT BRACE, MCA3	6061-T6 Al
0	0	0	0	0	0	0	1	33	D1101150	TUBE BAFFLE PLATE_UPPER-MCA1	18GA A424 TYPE 1 STEEL
0	0	0	0	0	0	0	1	32	D1101159	RECT BRACE, MCA1	6061-T6 Al
0	0	0	0	0	0	0	1	31	D1100277	INNER LOWER LEFT BRACE, MCA1	6061-T6 Al
0	0	0	0	0	0	0	1	30	D1100121	INNER UPPER LEFT BRACE, MCA1	6061-T6 Al
0	0	0	0	0	3	0	3	29	D1100987	AL APERTURE CLIP	6061-T6 Al
1	0	1	0	2	0	2	0	28	D1003059	APERTURE CLIP	304 SSSL
4	4	4	4	4	0	4	0	27	D1002998	APERTURE SIDE BRACE	304 SSSL
2	2	2	2	2	0	2	0	26	D1002997	APERTURE BRACE	304 SSSL
2	2	2	2	2	0	2	0	25	D1002996	APERTURE SUPPORT	304 SSSL
0	0	0	0	0	1	0	0	24	D1100513	LOWER APERTURE PLATE, MCA3	6061-T6 Al
0	0	0	0	0	1	0	0	23	D1100512	UPPER APERTURE PLATE, MCA3	6061-T6 Al
0	0	0	0	0	0	0	1	22	D1100469	LOWER APERTURE PLATE, MCA1	6061-T6 Al
0	0	0	0	0	0	0	1	21	D1100468	UPPER APERTURE PLATE, MCA1	6061-T6 Al
0	0	0	0	2	0	2	0	20	D1003109	APERTURE PLATE_75MM	18GA A424 TYPE 1 STEEL
2	0	2	0	0	0	0	0	19	D1003110	APERTURE PLATE_200MM	18GA A424 TYPE 1 STEEL
0	2	0	2	0	0	0	0	18	D1002995	APERTURE PLATE_1500MM	18GA A424 TYPE 1 STEEL
1	1	1	1	1	1	1	1	17	D1000779	MOUNT BRACKET_BOTTOM	6061-T6 Al
1	1	1	1	1	1	1	1	16	D1000780	MOUNT BRACKET_TOP	6061-T6 Al
0	0	0	0	1	1	1	0	15	D1003118-00	TUBE BAFFLE PLATE_UPPER - MCA	18GA A424 TYPE 1 STEEL
0	0	0	1	0	0	0	0	14	D1003118-01	TUBE BAFFLE PLATE_UPPER - MCB1	18GA A424 TYPE 1 STEEL
0	0	1	0	0	0	0	0	13	D1003118-02	TUBE BAFFLE PLATE_UPPER - MCB2	18GA A424 TYPE 1 STEEL
0	1	0	0	0	0	0	0	12	D1003118-03	TUBE BAFFLE PLATE_UPPER - MCB3	18GA A424 TYPE 1 STEEL
1	0	0	0	0	0	0	0	11	D1003118-04	TUBE BAFFLE PLATE_UPPER - MCB4	18GA A424 TYPE 1 STEEL
0	0	0	0	1	0	1	1	10	D1003119-00	TUBE BAFFLE PLATE_LOWER - MCA	18GA A424 TYPE 1 STEEL
0	0	0	1	0	0	0	0	9	D1003119-01	TUBE BAFFLE PLATE_LOWER - MCB1	18GA A424 TYPE 1 STEEL
0	0	1	0	0	0	0	0	8	D1003119-02	TUBE BAFFLE PLATE_LOWER - MCB2	18GA A424 TYPE 1 STEEL
0	1	0	0	0	0	0	0	7	D1003119-03	TUBE BAFFLE PLATE_LOWER - MCB3	18GA A424 TYPE 1 STEEL
1	0	0	0	0	0	0	0	6	D1003119-04	TUBE BAFFLE PLATE_LOWER - MCB4	18GA A424 TYPE 1 STEEL
10	10	10	10	10	11	10	11	5	D1002871	TUBE BAFFLE SPOKE	6061-T6 Al
1	1	1	1	1	1	1	0	4	D1002869	TUBE BAFFLE INNER LEFT BRACE	6061-T6 Al
1	1	1	1	1	0	1	1	3	D1002868	TUBE BAFFLE INNER RIGHT BRACE	6061-T6 Al
1	1	1	1	1	1	1	1	2	D1002867	TUBE BAFFLE LEFT BRACE	6061-T6 Al
1	1	1	1	1	1	1	1	1	D1001926	TUBE BAFFLE RIGHT BRACE	6061-T6 Al
-08 MCB4	-07 MCB3	-06 MCB2	-05 MCB1	-04 MCA4	-03 MCA3	-02 MCA2	-01 MCA1	ITEM NO.	PART NUMBER	DESCRIPTION	MATERIAL

**LIGO** CALIFORNIA INSTITUTE OF TECHNOLOGY  
 MASSACHUSETTS INSTITUTE OF TECHNOLOGY

SIZE DWG. NO. **D1002864** REV. **v1**

SCALE: 1:12 PROJECTION: SHEET 9 OF 9

D1002864.dwg; Models; Cleaner\_Tube\_Baffle\_Frame Assy; PART PDM REV.; DRAWING PDM REV. X-004