



COMPONENT SPECIFICATION

Pick Off Telescope

APPROVALS:	DATE	REV	DCN NO	BY	CHK	DCC	DATE
DRAWN: MICHAEL SMITH, JONATHAN KERN	10/6/98	A	E990073				
CHECKED:		B	E990077				
APPROVED:							
DCC RELEASE:							

1 SCOPE

This is a specification for the PO Telescope. This device is an afocal, off-axis Mersenne reflecting 8X beam-reducing telescope.

2 APPLICABLE DOCUMENTS

2.1. LIGO Documents

- LIGO-960641-05, Electronic Submissions to the Document Control Center
- LIGO-E960022, Vacuum Compatibility, Cleaning Methods and Compatibility Procedures
- LIGO-E960050, Vacuum Compatible materials list
- LIGO-E980129-00-D, Ligonian VI-B, 8x magnification, 1.3m,
- LIGO-E980129-00-D - Ligonian VI-B, 8x magnification, 1.3m <Optical Arrangement
- LIGO-D980391-00-D - PO_Telescopes_table_elevations.dwg <Heights of 8 various PO telescopes
- LIGO-L970196, Part Numbers and Serialization of Detector Hardware
- D980608-A-D Bar, Spring Strip Retainer
- D980607-A-D Bar, Spring Strip Mounting
- D980606-A-D Bracket Right Lower Baffle
- D980605-A-D Bracket Left Lower Baffle
- D980604-A-D Brace, Camera Target
- D980603-A-D Bracket Camera Target
- D980601-A-D Plate Lateral Adjustment
- D980600-A-D Vertical Plate, Jack Stand
- D980599-A-D Base, Jack
- D980598-A-D Base Plate, Jack
- D980597-A-D Glide plate, Jack
- D980596-A-D Vertical Plate, Jack Stand
- D980595-A-D Horizontal Plate, Jack Stand
- D980593-A-D Block Thumbscrew, Lateral Adjustment
- D980592-A-D Block Spring Plunger, Lateral Adj.
- D980589-A-D Bracket Alignment Telescope
- D980588-A-D Angle Alignment Telescope
- D980587-A-D Plate Alignment Telescope
- D980586-A-D Block Upper Baffle Retaining



COMPONENT SPECIFICATION

Pick Off Telescope Requirements

D980585-A-D Baffle, Upper
D980584-A-D Baffle, Lower
D980582-A-D Pin, Pivot
D980581-A-D Socket, Pivot
D980580-A-D Set Screw, Pivot
D980576-A-D Collar, Alignment Telescope
D980575-A-D Target
D980574-A-D Frame, Target
D980573-A-D Plate, Target Support, Short
D980572-A-D Plate, Target Support, Long
D980571-A-D Plate, Vertical Lock, Front Support
D980570-A-D Block, Interface, Vert. Lock
D980569-A-D Plate, Base Front Support
D980568-A-D Brace, Horiz., Front Support
D980567-A-D Gusset, Front, Front Support.
D980566-A-D Gusset, Rear, Front Support
D980565-A-D Bar, Vert., Front Support
D980560-A-D Stiffener, Vert., Rear Support
D980555-A-D Brkt., End Baffle
D980545-A-D Plate, Right, Mirror Box
D980544-A-D Plate, Left, Mirror Box
D980543-A-D Plate, Top, Mirror Box
D980542-A-D Plate, Bottom Mirror Box
D980314-00-D Y-Axis Top Plate
D980316-00-D Y-Top end Plate
D980564-A-D Plate Vert. Lock/Pivot, Rear Support
D980563-A-D Plate Base Rear Support
D980562-A-D Plate Swivel Rear Support
D980561-A-D Brace Horz. Rear Support
D980559-A-D Plate Vert. Rear Support
D980315-00-D X-Y Interface Plate
D980317-00-D X-Axis Way Plate
D980318-00-D Flexure Spring Block
D980319-00-D Flexure
D980320-00-D End Plate
D980321-00-D Angle Plate
D980614-A-D Bar, Left – End Baffle Long
D980615-A-D Bar, Right – End Baffle Long
D980558 -A-D Bar, Lower – End Baffle
D980553-A-D Angle, Lower, Left
D980554-A-D Angle, Lower, Right
D980591-A-D Plate, Lateral-Short
D980590-A-D Plate, Lateral-Long



COMPONENT SPECIFICATION

Pick Off Telescope Requirements

D980552-A-D Angle, Upper
D980546-A-D Sheet , Upper-Sq. Tube
D980551-A-D Front Plate
D980550-A-D Bulkhead –Title Plate
D980548-A-D Sheet Left, Sq. Box
D980547-A-d Sheet, Lower, Sq. Tube
D980549-A-D Sheet Right, Sq. Box

2.2. Other Documents

MIL-C-675C, Coating Adhesion and Durability

3 REQUIREMENTS

3.1. Performance characteristics

3.1.1. Optical Characteristics

3.1.1.1 Clear Aperture

The mirrors and the mechanical assembly shall allow unobstructed passage of an entering 160mm diameter collimated optical beam centered on the optical axis, which exits through the output port as a 20mm diameter collimated beam.

3.1.1.2 Field of View

The operational field of view shall be, $\Delta\theta = \pm 5 \times 10^{-4}$ rad.

3.1.1.3 Beam Reduction

The PO Telescope shall provide a nominal 8X beam reduction of a Gaussian intensity profile input beam. The Gaussian input beam waist parameter is $w = 36.4$ mm, located at the input aperture. The input beam diameter is 156mm.

3.1.1.4 Wavefront Aberration

The wavefront distortion of the output beam shall be < 0.25 waves p-v @ 1064nm for all input angles within the field of view.

3.1.1.5 Optical Transmissivity

The optical transmissivity through the telescope shall be $> 99.8\%$ @ 1064 nm



COMPONENT SPECIFICATION

Pick Off Telescope Requirements

3.1.1.6 Primary Mirror

3.1.1.6.1 Front Surface

Radius of curvature	-3048 mm +/- 30
Conic constant	-1.000 +/- 0.002
Parabola tilt, reference to back surface	+/- 0.03 deg
Clear aperture	200.7 mm
Edge displacement	108.00 +/- 0.5 mm
Diameter	203.2 +0.0, -0.1 mm
minimum edge thickness	43 mm +/- 1.0 mm
Surface irregularity	<0.25 wave peak to valley@ 633 nm over clear aperture
Surface finish	60/40
Surface roughness	<100 Ang

3.1.1.6.2 Back Surface

Surface quality	fine ground, >300 grit
-----------------	------------------------

3.1.1.7 Secondary Mirror

3.1.1.7.1 Front Surface

Radius of curvature	-381 mm +/- 4
Conic constant	-1.00 +/- 0.02
Parabola tilt, reference to back surface	+/- 0.05 deg
Clear aperture	32.0 mm
Off-axis displacement	26.20 +/- 0.5 mm
Diameter	34.0 +0.0, -0.1 mm
Minimum edge thickness	20.0 +/-0.6 mm
Surface irregularity	<0.25 wave peak to valley@ 633 nm over clear aperture
Surface finish	60/40
Surface roughness	<100 Ang

3.1.1.7.2 Back Surface

Surface quality	fine ground, >300 grit
-----------------	------------------------

3.1.1.8 Mirror Coating 1

Apply to primary and secondary mirror front surfaces

Front surface only	
Wavelength	1064 nm
Polarization	s
Incidence angle	4 deg
Multilayer dielectric coating, Reflectivity	>99.9%



COMPONENT SPECIFICATION

Pick Off Telescope Requirements

Durability per MIL-C-675C

3.1.1.9 Mirror Coating 2

Apply to primary and secondary mirror front surfaces

Front surface only

Wavelength 1064 nm

Polarization s

Incidence angle 4 deg

Protected Silver, Reflectivity >98%

Durability per MIL-C-675C

3.1.2. Mechanical Characteristics

3.1.2.1 PO Telescope Mechanical Assemblies

The PO Telescope consists of the following mechanical assemblies:

- 1) primary mirror mount,
- 2) secondary mirror mount,
- 3) telescope housing,
- 4) optical reference plate,
- 5) output flange,
- 6) front support,
- 7) tilt yoke,
- 8) height and tilt alignment fixtures,
- 9) input aperture alignment target, and
- 10) primary mirror aperture alignment target.

3.1.2.2 Telescope Configuration

The PO Telescope is used in two orientations,

- 1) **down**, primary mirror on the bottom, and
- 2) **up**, primary mirror on the top; in conjunction with two fixed heights and two adjustable heights; for a total of eight unique configurations; as shown in figure 1. The optical centerline height and the pitch angle are determined by the lengths and the attachment points of the front support and the rear tilt yoke support. The yaw angle is determined by translating the front support parallel to the optical table with respect to the rear tilt yoke support. The front of the telescope is the end where the secondary mirror is mounted, and the rear of the telescope is the end where the primary mirror is mounted.

3.1.2.3 Telescope Supports

All eight configurations and optical centerline heights shall be set with only three universal supports:



COMPONENT SPECIFICATION

Pick Off Telescope Requirements

- 1) fixed length front support,
- 2) fixed length rear support, and
- 3) tilt yoke.

3.1.2.4 Height and Tilt Adjustment Range

As a minimum; the height, height range, and tilt angle adjustments shall cover the range of values shown in Table1 on page6. The heights are measured from the surface of the optical table.

PO Telescope		Relative dim. in			tilt angle, deg
		nominal height gimbal, in	nominal height front support, in	height range, in	
2K	ITMx	15.63	15.69	0.0	-2.1
2K	ITMy	15.63	15.69	0.0	-1.9
2K	APS	10.43	10.46	0.5	-1.1
2K	BS	15.63	15.63	0.0	-0.1
4K	ITMy	15.63	15.63	0.0	0.0
4K	ITMx	15.63	15.63	0.0	0.0
4K	APS	8.78	8.81	0.5	-1.1
4K	BS	15.63	15.65	0.0	-0.6
4K - La	ITMy	15.63	15.63	0.0	0.0
4K - La	ITMx	15.63	15.63	0.0	0.0
4K - La	APS	8.78	8.81	0.5	-1.1
4K - La	BS	15.63	15.65	0.0	-0.6

Table 1: Height, height range, and tilt angle for the PO Telescopes

Additional mounting holes shall be provided on the sides of the telescope housing so that the front telescope supports can be moved to eliminate mechanical interferences with adjacent telescopes.

3.1.2.5 Focussing and Alignment of the Output Beam

The specified secondary mirror mount will provide focussing and alignment adjustments for the output beam. See “Secondary Mirror Mount” on page8.

3.1.2.6 Positioning and Fastening Requirements

The telescope assembly shall be positioned anywhere and securely fastened to the surface of the HAM SEI optical platform by means of the array of 1/4-20 tapped holes in a 2in X 2in pattern on the platform using clamps, as shown in figures 4, 5, 6 , and 7.



COMPONENT SPECIFICATION

Pick Off Telescope Requirements

3.1.2.7 Height and Tilt Alignment Fixtures

3.1.2.7.1 Tilt Yoke Assembly, Differential Screw Mover

The differential screw mover, as shown in figure 2. shall translate the tilt yoke assembly transverse to the optical axis within the required positioning range, with a minimum positioning repeatability of 0.01 inch.

3.1.2.7.2 Pitch Adjustment Mechanism

A removable pitch adjustment mechanism will be positioned under the PO Telescope approximately at the center of gravity to provide a fine pitch tilt adjustment. The pitch adjustment mechanism shall provide all the required pitch angles, within a minimum angle repeatability of 5×10^{-5} rad. The pitch adjustment mechanism shall allow the PO Telescope to translate in the plane of the optical table, while maintaining the minimum tilt repeatability.

3.1.2.7.3 Yaw Adjustment Mechanism

A removable yaw adjustment mechanism will be positioned at the front end of the PO Telescope to provide a fine yaw tilt adjustment. The yaw adjustment mechanism shall provide all the required yaw angles, within a minimum angle repeatability of 5×10^{-5} rad.

3.1.2.8 Input Aperture Alignment Target

A removable alignment target shall be placed at the entrance aperture of the PO Telescope within $\pm 20 \times 10^{-3}$ in of the optical centerline.

3.1.2.9 Primary Mirror Aperture Alignment Target

A removable alignment target shall be placed in front of the primary mirror of the PO Telescope within $\pm 20 \times 10^{-3}$ in of the optical centerline.

3.1.2.10 Optical Reference Surface

The optical reference surface shall be mounted perpendicular to the sides of the housing to within 4×10^{-4} rad.

3.1.2.11 Output Flange

An alignment telescope (not part of this specification) will be centered co-linear with the output optical centerline by means of the output flange which mounts to the optical reference surface. An adjustment means will be provided so that the output flange shall be positioned to within $\pm 2.5 \times 10^{-3}$ in of the optical centerline. The inside bore of the output flange shall be perpendicular to the optical reference surface to within 4×10^{-4} rad.



COMPONENT SPECIFICATION

Pick Off Telescope Requirements

3.1.2.12 Mechanical Tolerances

3.1.2.12.1 Primary Mirror Mount

The flat mounting surface of the primary mirror shall be fixed mounted parallel to the optical reference surface within 4×10^{-4} rad.

The center of the primary mirror shall be fixed mounted within $\pm 20 \times 10^{-3}$ in of the nominal primary mirror optical centerline.

3.1.2.12.2 Secondary Mirror Mount

The flat mounting surface of the secondary mirror shall be adjusted parallel to the optical reference surface within 0.05 deg.

The transverse position of the secondary mirror shall be adjusted so that the output optical axis is perpendicular to the optical reference surface within 0.05 deg.

The lateral position of the secondary mirror shall be adjusted to focus the cross hairs of the alignment telescope reticle.

The PO Telescope housing shall provide a compatible mounting interface for the secondary mirror mount whose preliminary design is detailed in the following referenced drawings.

3.1.2.13 Mechanical Vibration Characteristics

The telescope, and its associated mounting structure shall have no internal mechanical resonances < 100 Hz.

3.1.2.14 Size and Weight

- Maximum size envelope See "PO Telescope, side view" on page 13.
- Maximum weight of telescope without supports < 55 lb

3.2. DESIGN AND CONSTRUCTION

3.2.1. Materials

3.2.1.1 Mirrors

Substrate material	Zerodur or fused silica
Edge chamfer	0.25 mm @ 45 deg +/- 10deg

3.2.1.2 Mechanical Parts

3.2.1.2.1 Allowed Materials

It is desired that aluminum be used for all metal components, to the greatest extent possible. All materials must conform to LIGO document "LIGO-E960050, Vacuum Compatible materials list". No anodizing, or organic



COMPONENT SPECIFICATION

Pick Off Telescope Requirements

lubricants are permitted. Some elastomers may be allowed subject to approval by cognizant technical personnel.

3.2.1.2.2 Part Machining

• Liquid contaminants/Machining Lubricants

Liquids containing hydrocarbons or other contaminants, other than the machining fluids specified herein, shall not be allowed to come into contact with suspension material at any time. All machining fluids shall be water soluble and free of sulfur, chlorine and silicone; such as Cincinnati Milacron's Cimtech 410 (stainless steel).

• Grinding & Abrasive Cloth/Paper

Grinding (with abrasive wheels, cloth, or stones), or use of abrasive cloth or paper, is permitted, except where noted, if the ground or impacted surface is subsequently skimmed with a carbide tool to remove any residual contaminants. The use of oil free Arkansas stones are also approved to remove slight imperfections in the machined surfaces.

3.2.1.2.3 Dry Film Lubricants

Generally acceptable practice to prevent galling is to use stainless steel (CRES) hardware in aluminum substrate, or silver coated CRES hardware in CRES substrate.

3.3. Quality Assurance/Control

3.3.1. Identification

Separate (non-welded) parts and assemblies shall be marked with laser marking or acid etch techniques. A vibratory tool with a minimum tip radius of 0.0005" is acceptable for marking on surfaces which are not hidden from view. Engraving is also permitted.

Separate (non-welded) parts and assemblies to be serialized according to the document titled Part Numbers and Serialization of Detector Hardware, LIGO-L970196. This document allows for "bag-and-tag" type of identification for small parts.

3.3.1.1 Optical Alignment Marks

Edge tick-mark shall be placed to indicate orientation of mirror next to the optical axis:

0.24 +/- 0.05 mm wide x 20 mm +/- 2 mm long.

3.3.1.2 Serial Number

3.3.1.2.1 Optical Serial Number

A serial number identifying a component set of primary and secondary mirrors shall be etched, ground or sand-blasted next to the alignment mark.



COMPONENT SPECIFICATION

Pick Off Telescope Requirements

3.3.1.2.1.1 Serial Number Format

The Serial number shall be of the format:

E980262-y S/N *nnn-c* Where

E980262-y is the LIGO piece part or assembly drawing number, E980262, including the revision letter, -y, to which the hardware item was built;

nnn is the sequential serial number, 001 through 999, in the order produced,

and c=1 describes the dielectric mirror coating, c=2 describes the protected silver mirror coating.

3.3.1.2.2 Mechanical Serial Number

A serial number shall be etched, embossed, or marked with a stylus on each fabricated piece part of the telescope assembly.

3.3.1.2.3 Serial Number Format

The Serial number shall be of the format:

Dxxxxxx-y S/N, Where

Dxxxxxx-y is the LIGO piece part or assembly drawing number, Dxxxxxx, including the revision letter, -y, to which the hardware item was built.

3.3.2. Quality Assurance Provisions

A first article shall be produced and inspected for form, dimensions and workmanship.

3.3.3. Purchaser Access

Non-escort privileges for the buyer, owner, government and owner representatives to all areas of the facilities where work is being performed shall be arranged. This will include access to all areas where material is being processed and stored. The purchaser shall have the right to witness all manufacturing processes.

3.3.4. QA Approval

LIGO QA reserves the right to inspect and approve vendor/fabricator QA plan and processes.

4 TEST PROCEDURES

The assembled telescope performance shall be verified by the following test procedures

4.1. WAVEFRONT DISTORTION

Interferogram of transmitted wavefront across clear aperture, @1064nm wavelength



COMPONENT SPECIFICATION

Pick Off Telescope Requirements

4.2. Transmissivity

Transmissivity measurement across clear aperture, @1064nm wavelength

4.3. Vibration Test

TBD

5 DOCUMENTATION

- 1) Vibration analysis
- 2) Working drawings for component parts, in AutoCad 14 format on LIGO title block
- 3) Top assembly drawing, in AutoCad 14 format on LIGO title block
- 4) DOD-STD-100, MIL-STD-1000 and ANSI-Y14.5M-1982, or ASME-Y14.5-1994 standards shall be applied where appropriate
- 5) Compliance Certification for items 3.1., 3.2., 3.3., 4.
- 6) Materials Certification

6 ENVIRONMENTAL CHARACTERISTICS

The PO Telescope will operate in a non-vibrational, ultra high vacuum environment, at room temperature (68F,+/-4F).

7 HANDLING AND SHIPPING PROCEDURES

7.1. Cleaning

Approved cleaning procedures for UHV components are detailed in LIGO-E960022, Vacuum Compatibility, Cleaning Methods and Compatibility Procedures.

7.1.1. Optical Surfaces

All optical surfaces shall be cleaned in accordance with good commercial practice. Nothing shall contact the optical surfaces after cleaning, except for lint-free lens tissue.

7.1.2. Mechanical Parts

Mechanical parts shall be degreased in a clean solvent.

7.1.3. Disassembly for Cleaning

The telescope assembly will be disassembled for cleaning of all components. All surfaces shall be cleaned in accordance with good commercial practice.



COMPONENT SPECIFICATION

Pick Off Telescope Requirements

7.2. Packaging for Shipment

7.2.1. Optical Parts

The cleaned and disassembled optical components shall be protected with 6 layers of lint-free lens tissue, and placed in a sealed, clean polyethylene bag before shipping.

7.2.2. Mechanical Parts

The cleaned and disassembled mechanical components shall be placed in a sealed, clean polyethylene bag before shipping. Dissimilar components will not be mixed, but individual components of a like kind may be placed in a single bag, and tagged according to their part number (see sec 3.3.1.).

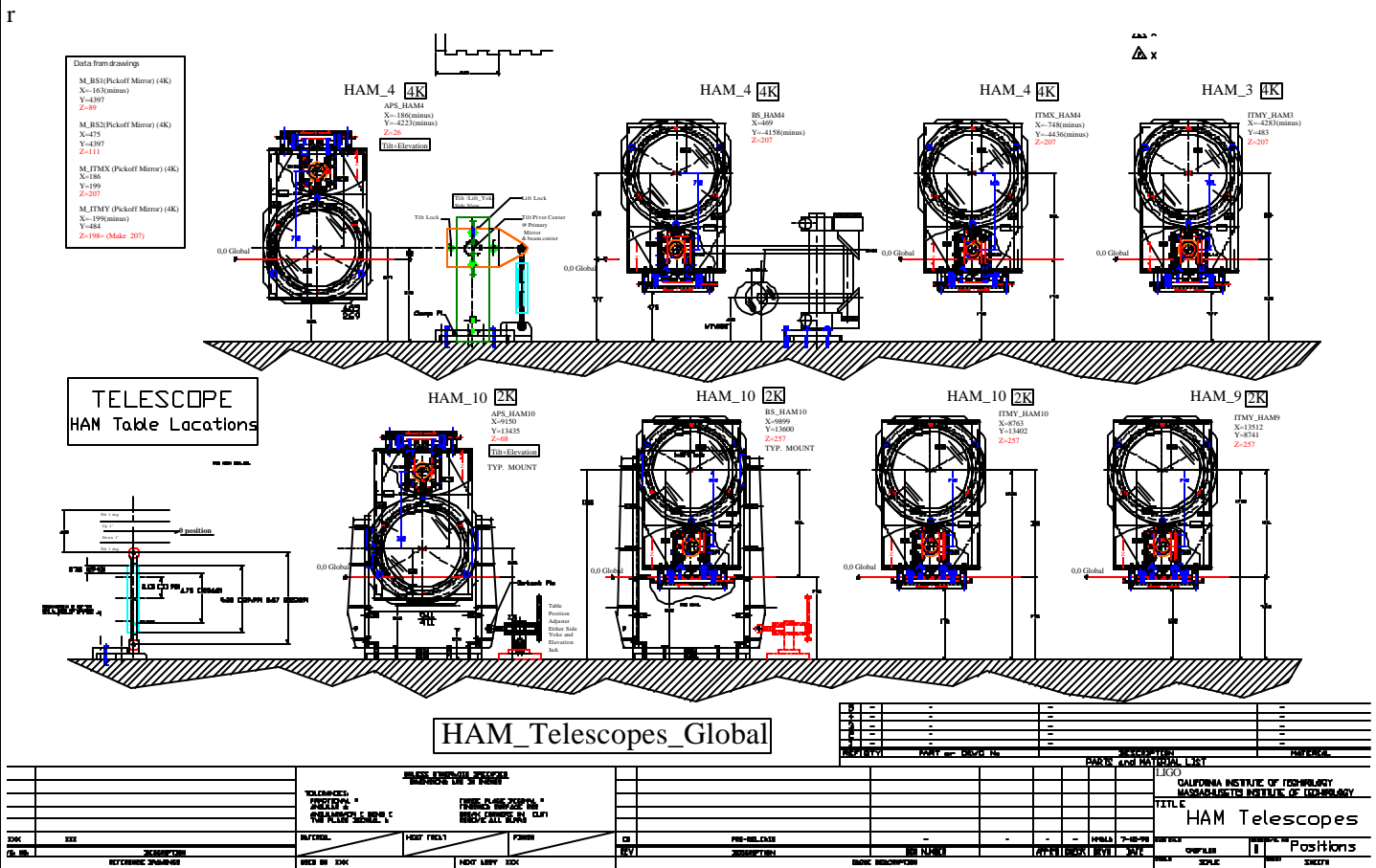

Figure 1: Eight PO Telescope configurations



COMPONENT SPECIFICATION

Pick Off Telescope Requirements

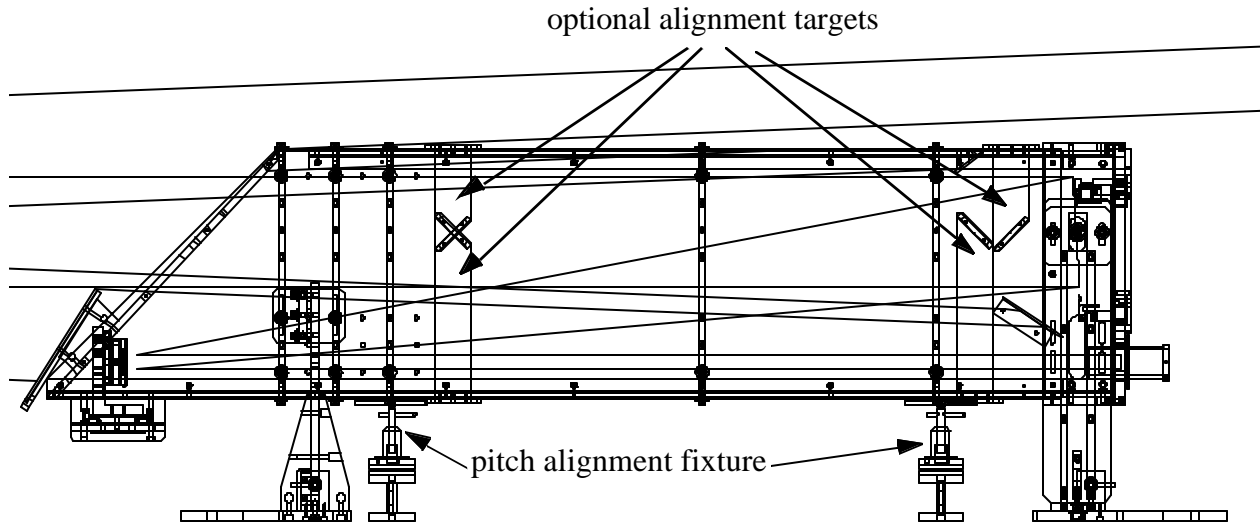

Figure 2: PO Telescope, side view

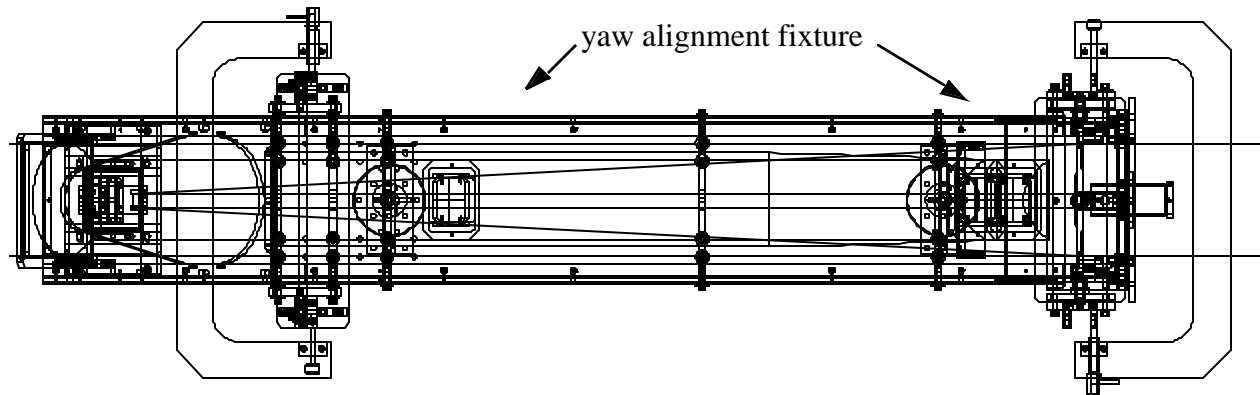

Figure 3: PO Telescope, top view



COMPONENT SPECIFICATION

Pick Off Telescope Requirements

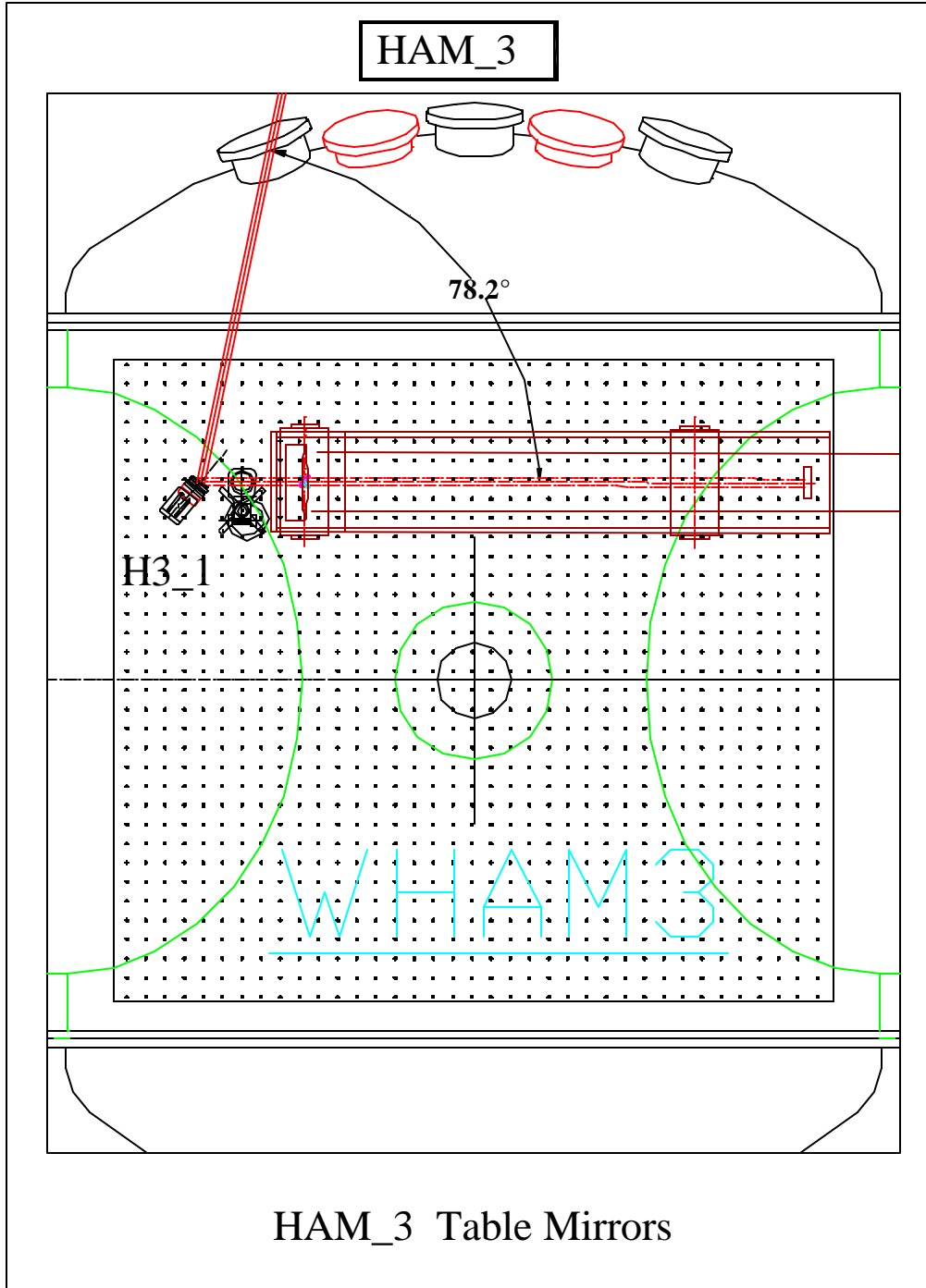

Figure 4: PO Telescope 4K ITMy, orientation



COMPONENT SPECIFICATION

Pick Off Telescope Requirements

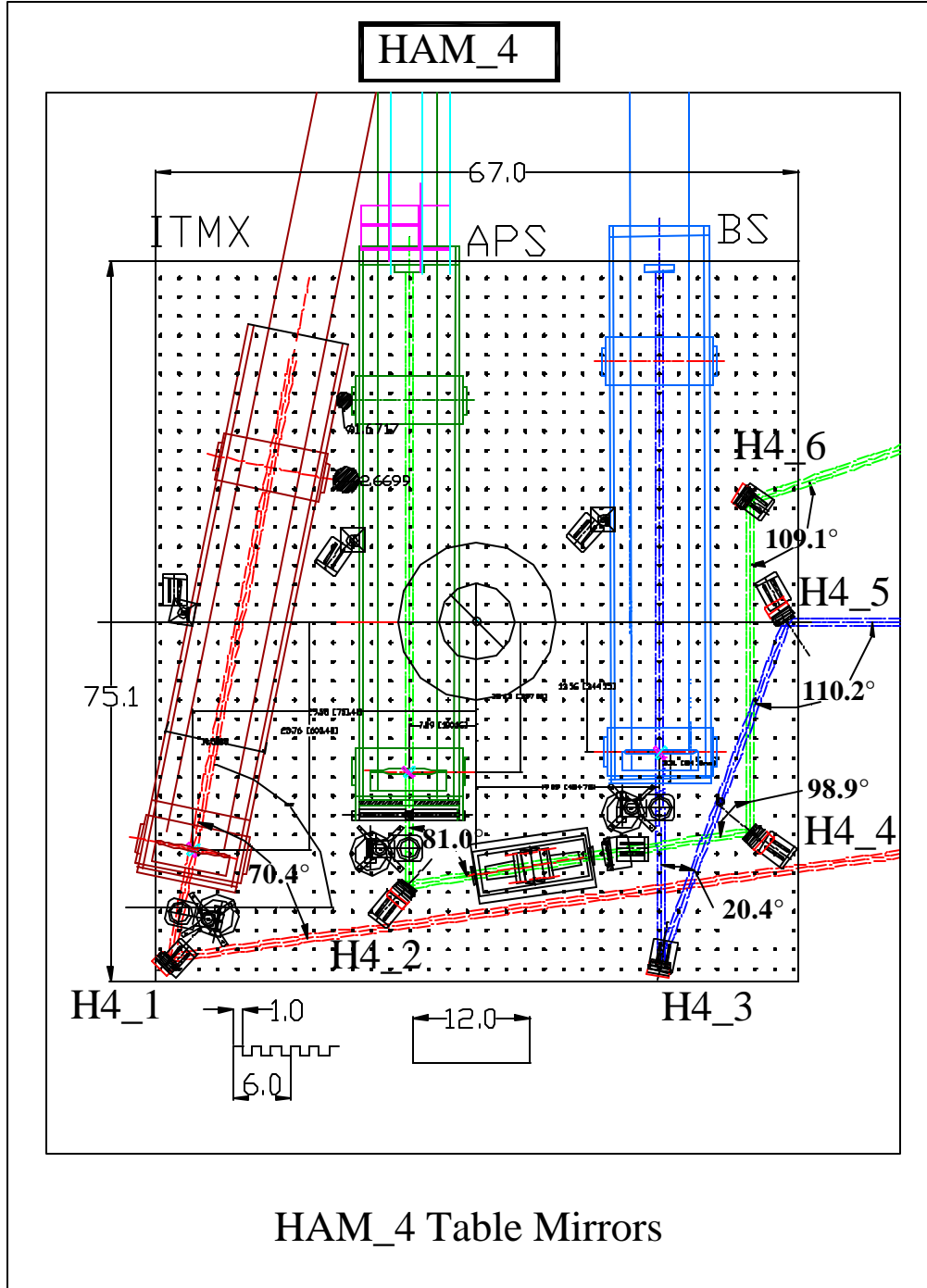

Figure 5: PO Telescopes 4K ITMx, 4K BS, 4K APS orientation



COMPONENT SPECIFICATION

Pick Off Telescope Requirements

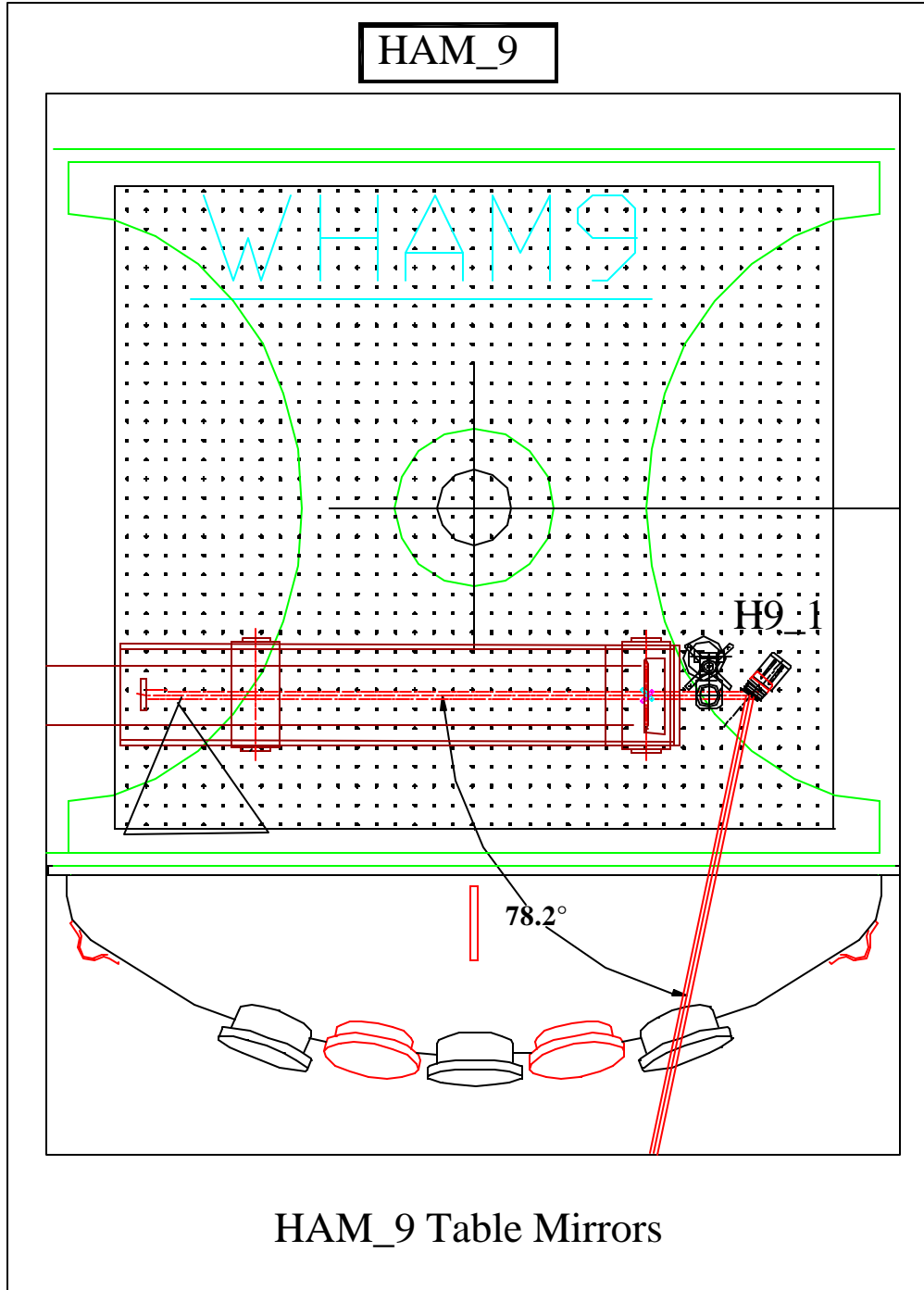

Figure 6: PO Telescope 2K ITMx, orientation



COMPONENT SPECIFICATION

Pick Off Telescope Requirements

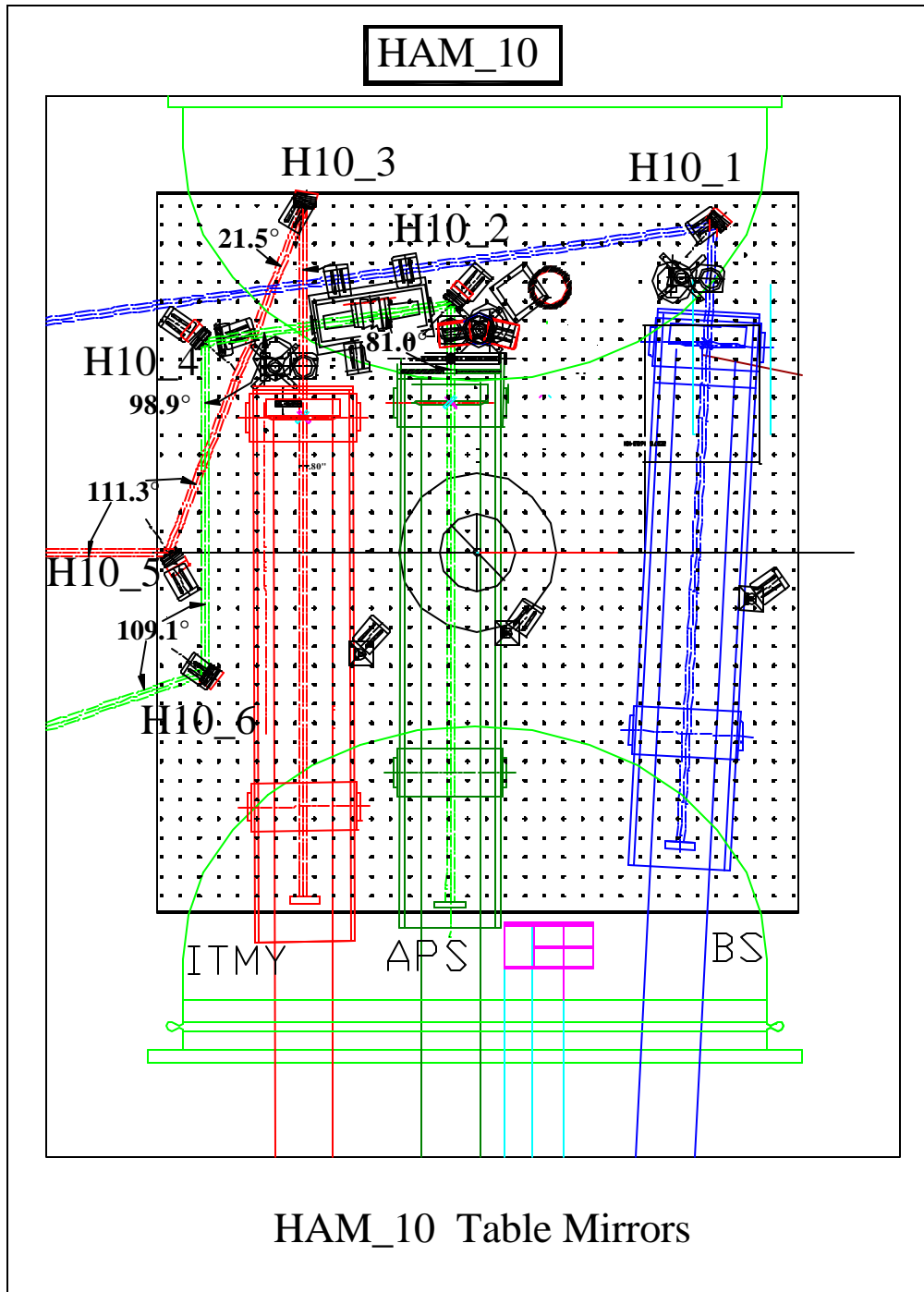

Figure 7: PO Telescopes 2K ITMy, 2K BS, 2K APS orientation



COMPONENT SPECIFICATION

Pick Off Telescope Requirements

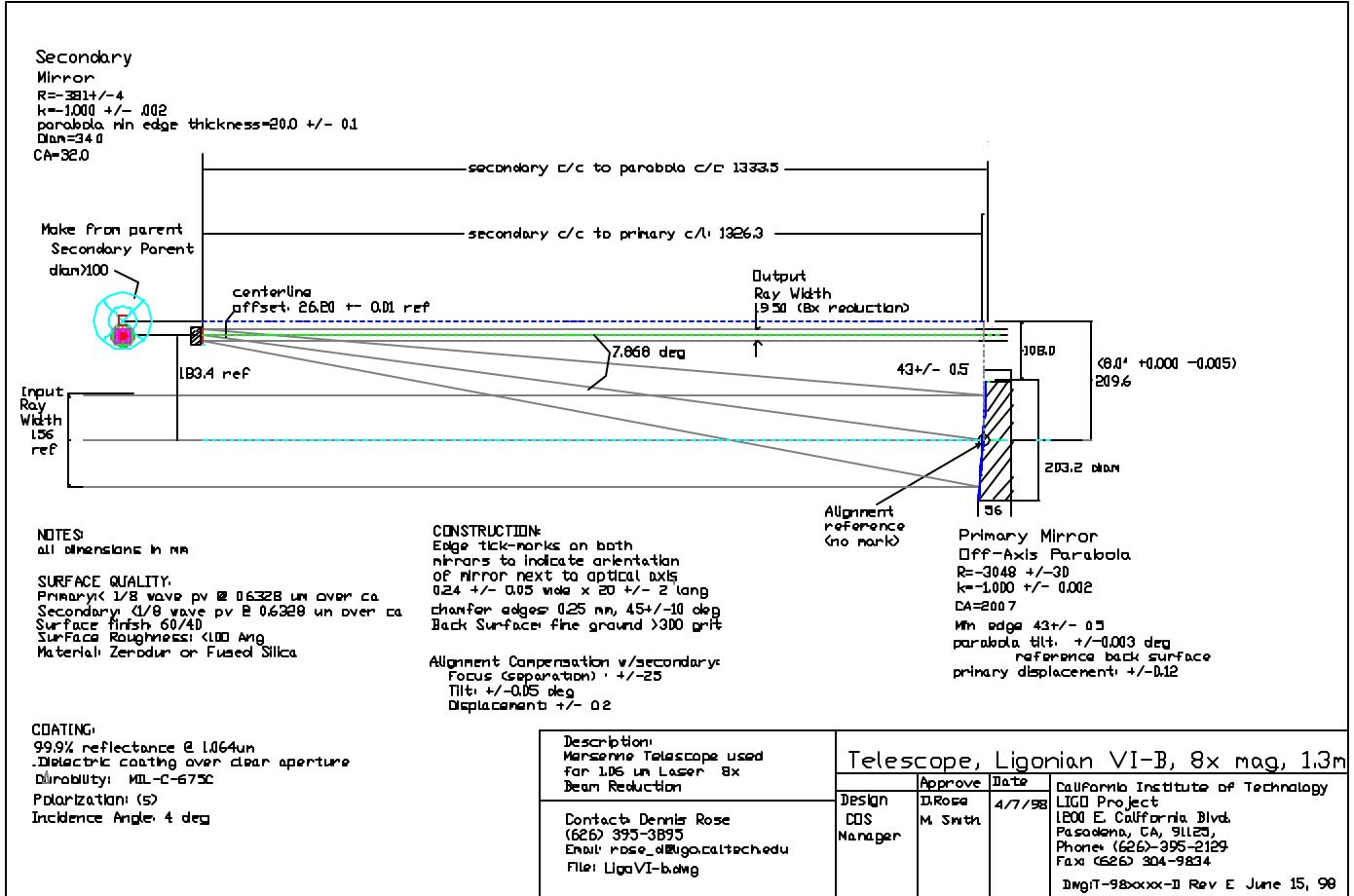

Figure 8: Optical schematic layout for PO telescope