

- NOTES CONTINUED:
5. SCRIBE, ENGRAVE (A VIBRATORY TOOL MAY BE USED), LASER MARK OR MECHANICALLY STAMP (NO INKS OR DYES) DRAWING PART NUMBER, REVISION (AND VARIANT OR 'TYPE' IF APPLICABLE) ON NOTED SURFACE OF PART FOLLOWED ON THE NEXT LINE WITH A THREE DIGIT SERIAL NUMBER. SERIAL NUMBERS START AT 001 FOR THE FIRST ARTICLE AND PROCEED CONSECUTIVELY. USE MINIMUM 0.12" HIGH CHARACTERS, UNLESS THE SIZE OF THE PART DICTATES SMALLER CHARACTERS. EXAMPLE: DXXXXXX-VY, TYPE-XX, S/N XXX
 6. APPROXIMATE WEIGHT=1.617 LB.
 7. MACHINE ALL SURFACES TO REMOVE OXIDES AND MILL FINISH. USE OF ABRASIVE REMOVAL TECHNIQUES IS NOT ALLOWED.
 8. ALL PARTS SHALL BE MANUFACTURED IN ACCORDANCE WITH LIGO SPECIFICATION E0900364.
 9. ALL MATERIAL IS TO BE VIRGIN MATERIAL (i.e. NOT WELD REPAIRS OR PLUGS UNLESS APPROVED IN ADVANCE IN WRITING BY LIGO, REFER TO LIGO-E0900364).

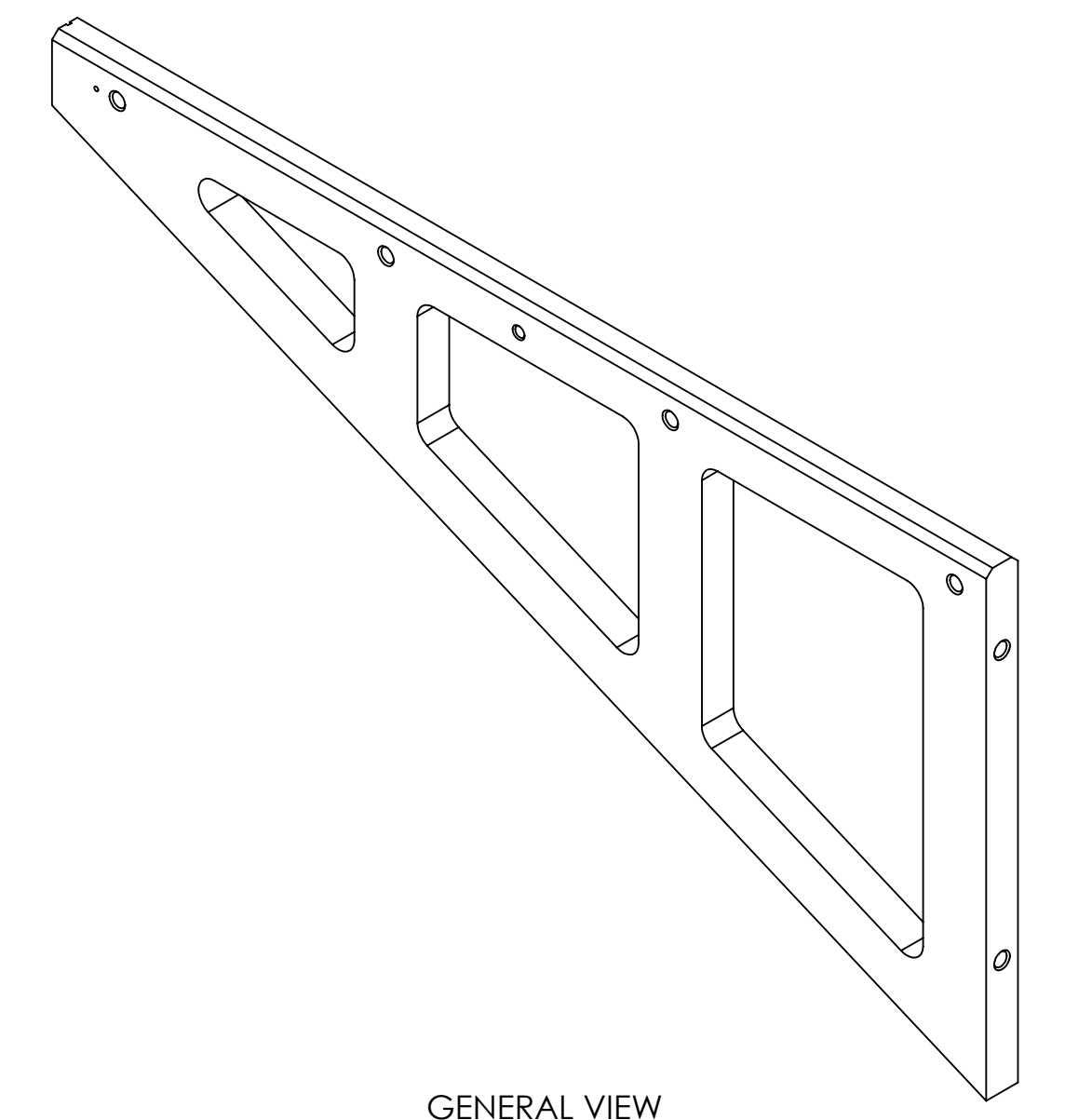

GENERAL VIEW FOR REFERENCE ONLY NO SCALE

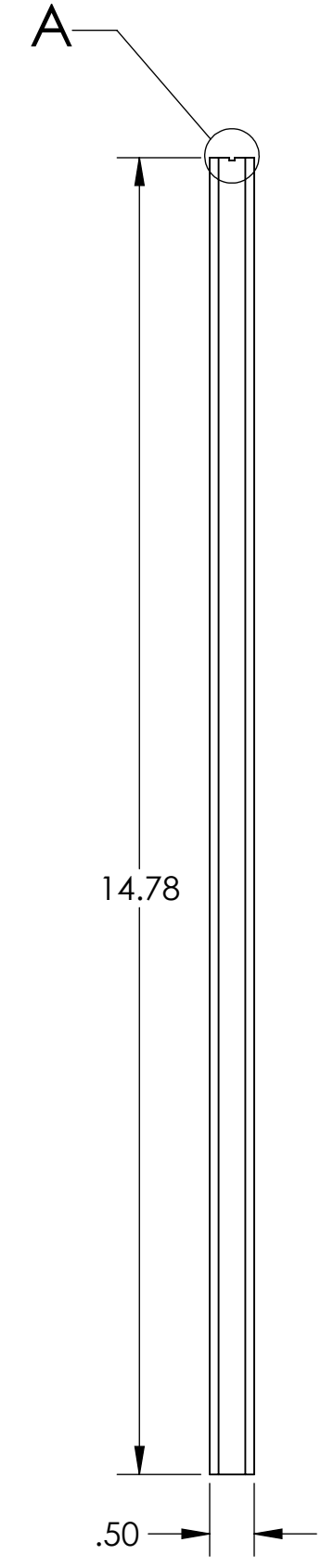
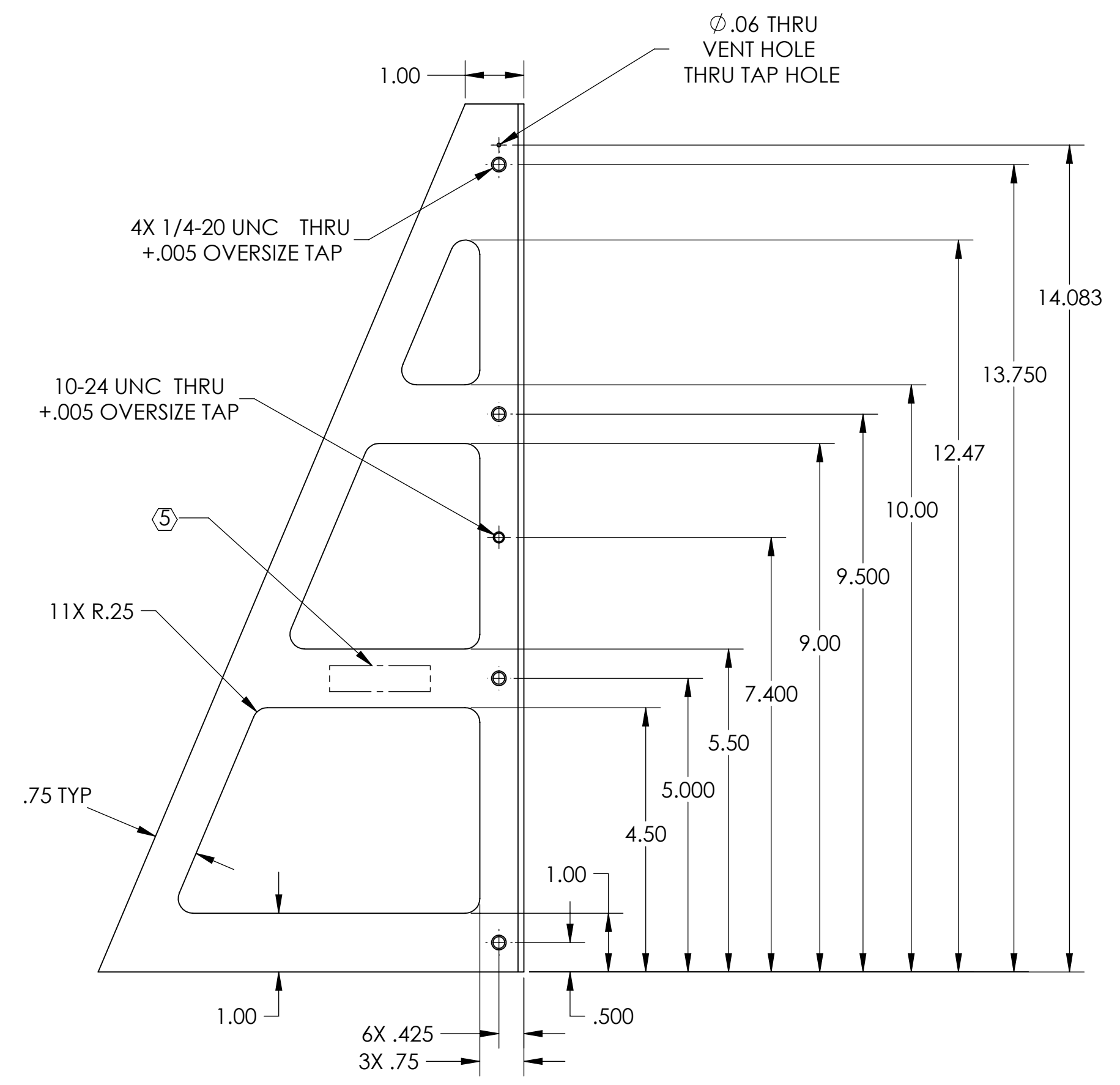
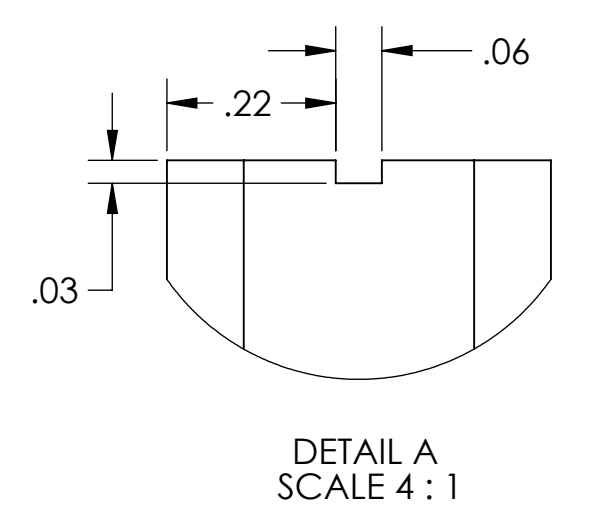
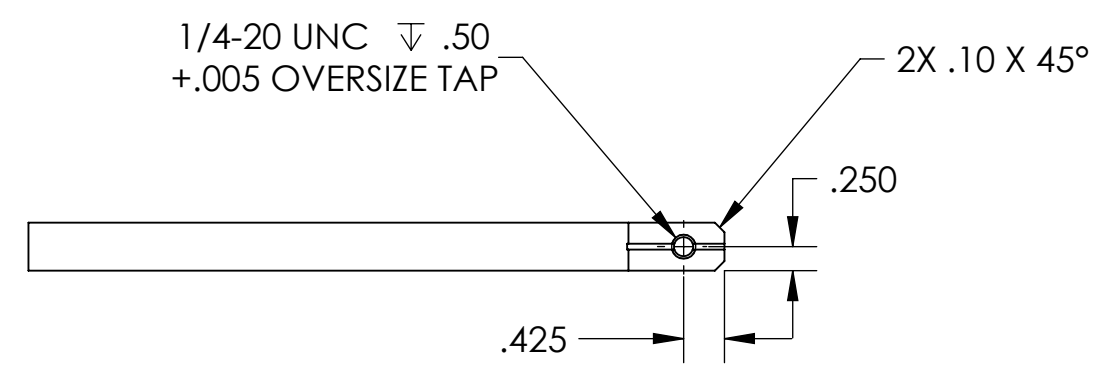
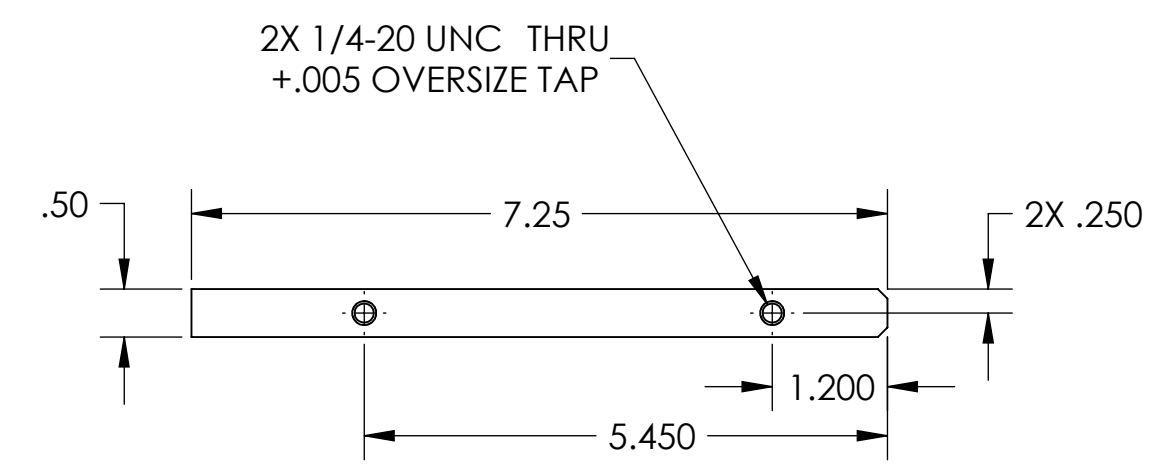

DIMENSIONS ARE IN INCHES	
TOLERANCES: .XX ± .01 .XXX ± .005	
ANGULAR ± 1.0°	
MATERIAL	6061-T6
FINISH	63 μinch

NOTES AND TOLERANCES: (UNLESS OTHERWISE SPECIFIED)	
1. INTERPRET DRAWING PER ASME Y14.5-1994. 2. REMOVE ALL SHARP EDGES, .005-.015. 3. DO NOT SCALE FROM DRAWING. 4. ALL MACHINING FLUIDS MUST BE FULLY SYNTHETIC, FULLY WATER SOLUBLE AND FREE OF SULFUR, SILICONE, AND CHLORINE.	
SYSTEM	ADVANCED LIGO
SUB-SYSTEM	AOS
NEXT ASSY	D1003205

PART NAME		ALIGO SR3 BAFFLE VERTICAL SUPPORT	
DESIGNER	C. WILKERSON	18 DEC 2010	SIZE DWG. NO.
DRAFTER	TG. NGUYEN	3 OCT 2011	D D1003172
CHECKER	L. AUSTIN	4 NOV 2011	
APPROVAL	M. SMITH	4 NOV 2011	SCALE: 1:2
PROJECTION:		SHEET 1 OF 1	

D:\003172\ALIGO SR3 BAFFLE VERTICAL SUPPORT - PART PDM REV: X037 DRAWING PDM REV: X041