



DRAFT

LIGO Laboratory / LIGO Scientific Collaboration

LIGO- T070238-02-D

ADVANCED LIGO

JUNE 24, 2008

Masses of Recycling Mirror System: suspended, non-suspended, and structure

Greer Scarborough and Bob Kirsner

Distribution of this document:
LIGO Science Collaboration

This is an internal working note
of the LIGO Project.

California Institute of Technology
LIGO Project – MS 18-34
1200 E. California Blvd.
Pasadena, CA 91125
Phone (626) 395-2129
Fax (626) 304-9834
E-mail: info@ligo.caltech.edu

Massachusetts Institute of Technology
LIGO Project – NW17-161
175 Albany St
Cambridge, MA 02139
Phone (617) 253-4824
Fax (617) 253-7014
E-mail: info@ligo.mit.edu

LIGO Hanford Observatory
P.O. Box 1970
Mail Stop S9-02
Richland WA 99352
Phone 509-372-8106
Fax 509-372-8137

LIGO Livingston Observatory
P.O. Box 940
Livingston, LA 70754
Phone 225-686-3100
Fax 225-686-7189

<http://www.ligo.caltech.edu/>

DRAFT

DRAFTRevision

00: Limited release

01: Includes updated information included after internal structure review on 17th Oct 2007

02: Includes updated information resulting from design change by Mike Gerfen, to make frame top surface absolutely level on 24th June 2008

Reference / Related Documents

http://ilog.ligo-wa.caltech.edu:7285/advligo/RM_Suspensions

LIGO-T070169 Summary of Work on RM Structure including FEA

LIGO-G070656 LSC Talk Hannover 2007 Welding Experiences: Output Modecleaner and Recycling Mirror Designs

1 Introduction

This document lists the masses in the recycling mirror suspension system and the FEA model of it. The system is primarily divided into the suspended, non-suspended and structural component masses. Mass contingency for the FEA model is created by the small amount in the system mass budget, the difference of the model masses and the actual masses of the non-suspended components and the difference of the top plate mass simulator and actual mounting pad. These contingencies are listed in table 6 of this document and total **27.38 kilograms**.

This document is a draft only and requires substantial edits. The key information is located in the Tables throughout the document.

2 RM System Mass Budget

Table 1 named RM System Mass Budget list principal elements of the RM system. The suspension is all the components which are hanging from the structure that flexes and dampens while supporting the test mass, to absorb any energy from vibrations. The non-suspended components are all the brackets and electrical equipment that is rigidly attached to the structure and assists with the mitigation of the vibration. The other components are the structure which is the frame of the system and the dog clamps that attaches

DRAFT

this frame to the optical table for testing. Table 1 shows that all the components plus a small contingency add up to 120 kilograms.

3 Non Suspended Masses

Table 2 named FEA Lumped Mass, Non Sus and Table 3 named FEA Lumped & Actual Mass, Non Sus lists the mass simulators for the non-suspended elements of the RM suspension system. The masses are created by very small parts that are attached to the structure. They have an extremely high density so as to simulate the masses of the non suspended components, which are rigidly attached to the structure. The list starts at the top of the frame with the blade assembly and blade guard. The blade assembly mass simulates the components and structural attachments to the mounting pad of the first flexing elements, including blades. The blade guard mass represents the structure that prevents the blade from having large upward vertical deflections. The table cloth mass accounts for all the non suspended brackets and electrical equipment, which senses and dampens the vibration of the second level of the suspension system. Non suspension elements at this level are rigidly attached to a RM structure, next to the suspended table cloth structure. The Intermediate Mass functions like the previous simulator except it functions at the third level called the intermediate. The test mass simulates the masses of similar elements, except that they function at the recycling mirror level at the bottom. To simulated masses that are roughly distributed all over the structure, many lumped masses are used to simulate one component. The blade assembly is represented by two lumped masses while the other components are each represented by four masses. Table 2 has two columns of numbers. The first lists the non suspended masses used in the FEA model and the second lists the densities of these masses that are entered into Cosmos. The Cosmos FEA solids require material properties and so the lumped masses are first assigned the properties of steel, and then the densities are edited, so the solids masses will conform to the budgeted masses of table 2. Table 3 has two columns of numbers. The first lists the non suspended masses used in the FEA model and the second list contains the actual masses of these

DRAFT

components. The difference in the totals of these two columns represents a large contingency of 3.2 kilograms.

4 RM Structure Masses

The table 3 named RM structure and mounting pads lists the elements of the RM structure used in the FEA model. There are two basic elements of the actual structure: frame and mounting pads. The existing FEA model only has the frame and a feature called the top plate that is welded to it. In the earlier model, this feature actually functioned as a support for the blade assembly. It now only serves to simulate the mass of the part that will replace it, which is called the mounting pad. A final contingency is created by the fact that the top plates are about **half** kilogram heavier than the actual mounting pads that are in the real structure.

DRAFT

1 RM System Mass Budget

Update 21Sept 2007

dog clamps	4.2 kg
suspension	36.4 kg
non suspended	12.8 kg
upper limit for structure	65.0 kg
small contingency	1.6 kg
TOTAL	120.0 kg

Payload Mass Properties, SEI (E040136-00, Dennis Coyne)

DRAFT**2 FEA Lumped Mass, Non Sus**

Update 21Sept 2007

NAME	BUDGET	QUANTITY	DENSITY¹ X 10⁶
Blade Assembly ¹	4.0 kg	2	19.0 kg / m ³
Blade Guard	0.5 kg	4	1.2 kg / m ³
Tablecloth	4.3 kg	4	10.2 kg / m ³
Intermediate Mass	2.0 kg	4	4.8 kg / m ³
Test Mass	2.0 kg	4	4.8 kg / m ³
TOTAL NON SUS MASS	12.8 kg	N/A	N/A

Figure 5 lumped masses and RM structure

1. Density of Blade Assembly lumped mass

$$density = \frac{(4/2)Kg}{105mm^3} \times \left(\frac{mm^3 \times 10^9}{m^3} \right) = 19.0 \times 10^6 \frac{Kg}{m^3}$$

DRAFTSummary of its use of Lumped Mass

Each lumped mass added to the FE model has a volume of 105 mm^3 . In the CAD model prepared for FEA we add lumped mass to represent the non-suspended mass as follows: -

- Blade Assembly
 - 2x lumped masses each of density = $1.9\text{e}7$ & mass = 2 kg to rep total Blade Assembly budget of 4 kg!
- Blade Guard
 - 4x lumped masses each of density = $1.19\text{e}6$ & mass = 0.125 kg to rep total Blade Guard budget of 0.5 kg!
- Tablecloth
 - 4x lumped masses each of density = $1.02\text{e}7$ & mass = 1.07 kg to rep total Tablecloth budget of 4.3 kg!
- Int Mass
 - 4x lumped masses each of density = $4.7\text{e}6$ & mass = 0.5 kg to rep total Int Mass budget of 2 kg!
- Test Mass
 - 4x lumped masses each of density = $4.7\text{e}6$ & mass = 0.5 kg to rep total Test Mass budget of 2 kg!

DRAFT

3 Budget compared to Actual

Update 21Sept 2007

NAME	BUDGET	ACTUAL
Blade Assembly	4.0 kg	4.120 kg
Blade Guard	0.5 kg	0.480 kg
Tablecloth	4.3 kg	3.370 kg
Intermediate Mass	2.0 kg	0.763 kg
Test Mass	2.0 kg	0.911 kg
TOTAL NON SUS MASS	12.8 kg	9.644 kg

DRAFT

4 RM structure and mounting pads

Update 24 June 08

frame and plates ¹	67.296 kg
2 top plates ²	1.522 kg
frame only ³	65.774 kg
2 Mounting pads ⁴	1.002 kg

1. Figure 2, RM structure (D070411), mass (17 Oct 07) from frequency studies, new configuration with more access holes in lower cross beam will change mass.
2. Figure 2, 3, top plates (steel, 17 Oct 07) only for mass simulation replaced by mounting pads (D070374, aluminum)
3. Figure 1, 2, frame mass (17 Oct 07) from frequency studies, new configuration with more access holes in lower cross beam will change mass.
4. Figure 1, 4, mounting pads mass (24 June 08) from stress and frequency studies

DRAFT**5 RM structure mass history**

Update 24 June 08

No.	DESCRIPTION	Kg	REASONS	DATE
1	FEA model, 1/4" tubes plus 1/4" & 3/8" gussets, D070411 ³	65.77	Original FEA model	17Oct07
2	Assembly model, 1/8" tubes plus 1/4" & 3/8" gussets, no welds, tube holes D070442 REV 00 ⁴	42.88	Ray (welder) said thinner tubes created smaller tube fillets, resulting in better welds, also less warping ¹	20Dec08
3	Assembly model, 1/8" tubes plus 1/8" gussets, no welds, tube holes D070442 REV 21 ⁴	40.76	Mike G. said thinner gussets created less warping from welds ²	8Apr08
4	Assembly model, 1/8" tubes & 3/16" top tubes plus 1/8" gussets, no welds, tube holes, top surface machined D070442 REV 13 ⁴	42.41	Mike G. said thicker top tube allowed machining top surface level	31May08

WELD SAMPLE RESULTS

1. First weld sample showed that the thick tubes and gussets warp the structure to much. A side gusset is needed to keep the base plate from warping. OCT. 16, 2007. D070297 ⁵
2. Second weld sample showed that the very thick gussets warped the structure more than a quarter of an inch. FEB. 22, 2008. D070459 ⁶

DRAFT

PATH TO DATA IN VAULT

3. Vault / SUSPENSION / CPTYPE RM / 03 STRUCTURE 4 FEA / D070411_RM_structure old.sldprt

4. Vault / SUSPENSION/CPTYPE RM CONTROLS DESIGN 2007 / 00 ASSEMBLY / D070447_ADVANCED LIGO SUS RM OVERALL ASSEMBLY STR AND SUS.SLDASM/D070537_ALIGO_RM_structure_&_mounting_pad.SLDASM / D070442_ALIGO_RM_structure_weldment.SLDASM

5. Vault / SUSPENSION/CPTYPE RM / 03 STRUCTURE 4 FEA/D070411_RM_structure.sldprt / D070297_weld_sample.slddrw

6. Vault / SUSPENSION / CPTYPE RM / 03 STRUCTURE 4 FEA / D070409_Recycling_Mirror_Assy.SLDASM / attachment holes mess_D070411_RM_structure.sldprt / D070459_double_gusset_weld_sample.slddrw

DRAFT**RM System Mass Contingency**

Update 24 June 08

budget, structural frame	65.00 kg
contingency, system	1.60 kg
frame plus contingency	66.60 kg
actual frame 24 June 08	-42.38 kg
potential weight saving from actual box section ¹	0.00 kg
SUBTOTAL FRAME CONTINGENCY	24.22 kg
contingency, non sus	3.16 kg
contingency, pads ²	0.00 kg
TOTAL SYSTEM CONTINGENCY	27.38 kg

1. The old model had tube that required a correction because it had no fillets in box section
2. The old model had a top plate that required a correction because it was more massive than pad

DRAFT

RM suspension assembly Figure 1

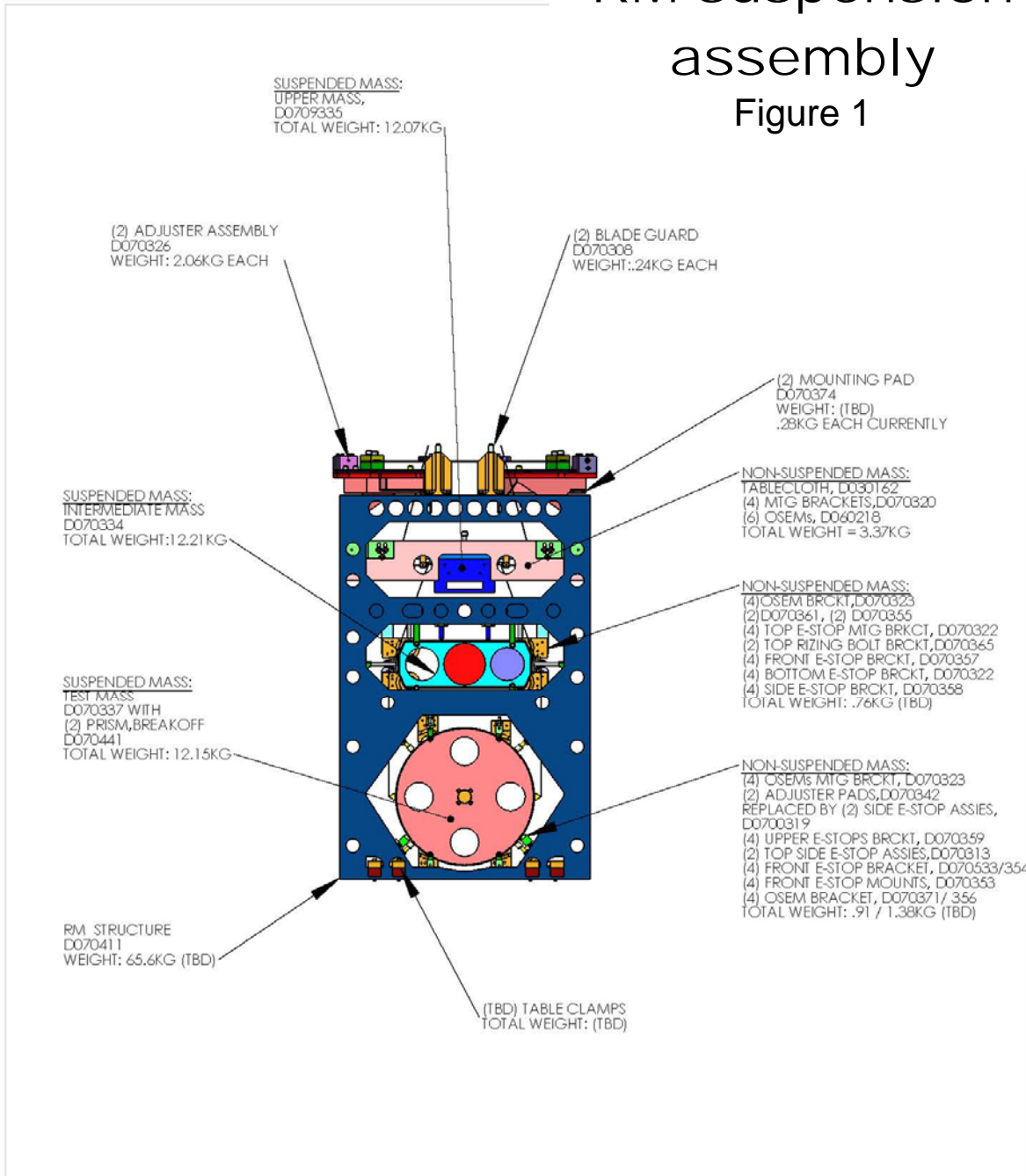

<p>PROPRIETARY AND CONFIDENTIAL THE INFORMATION CONTAINED IN THIS DRAWING IS THE SOLE PROPERTY OF <INSERT COMPANY NAME HERE>. ANY REPRODUCTION IN PART OR AS A WHOLE WITHOUT THE WRITTEN PERMISSION OF <INSERT COMPANY NAME HERE> IS PROHIBITED.</p>			DIMENSIONS ARE IN INCHES TOLERANCES: FRACTIONAL ± ANGULAR: MACH ± BEND ± TWO PLACE DECIMAL ± THREE PLACE DECIMAL ±	NAME B.KIRSNER	DATE 09/20/07	
			MATERIAL	DRAWN CHECKED ENG APPR. MFG APPR. Q.A. COMMENTS:		
			FINISH			<p style="text-align: center;">ASSEMBLY RM SUSPENSION</p> SIZE DWG. NO. D070306 REV. SCALE: 1:10 WEIGHT: SHEET 1 OF 1
			APPLICATION	DO NOT SCALE DRAWING		

DRAFT

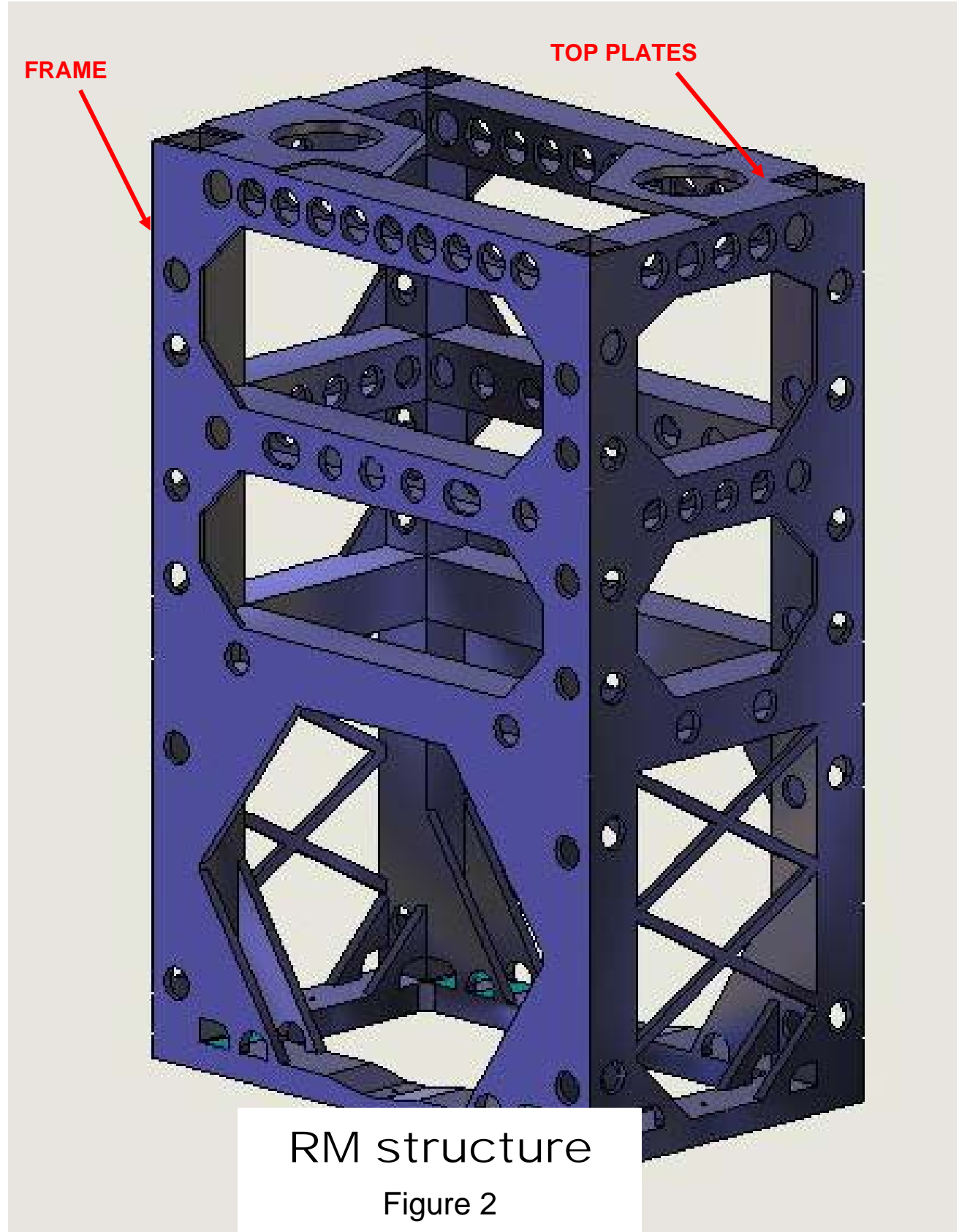

RM structure
Figure 2

DRAFT

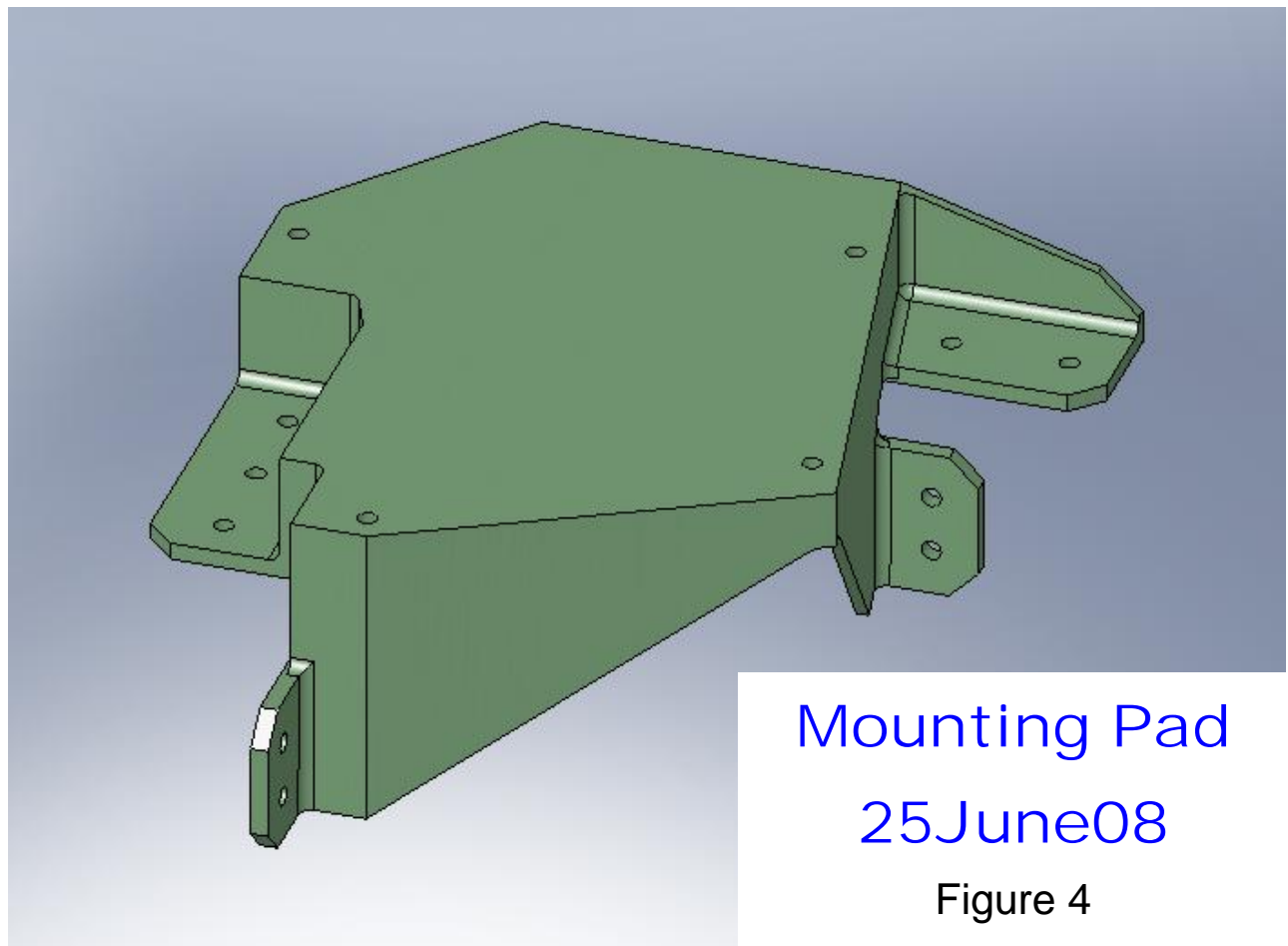
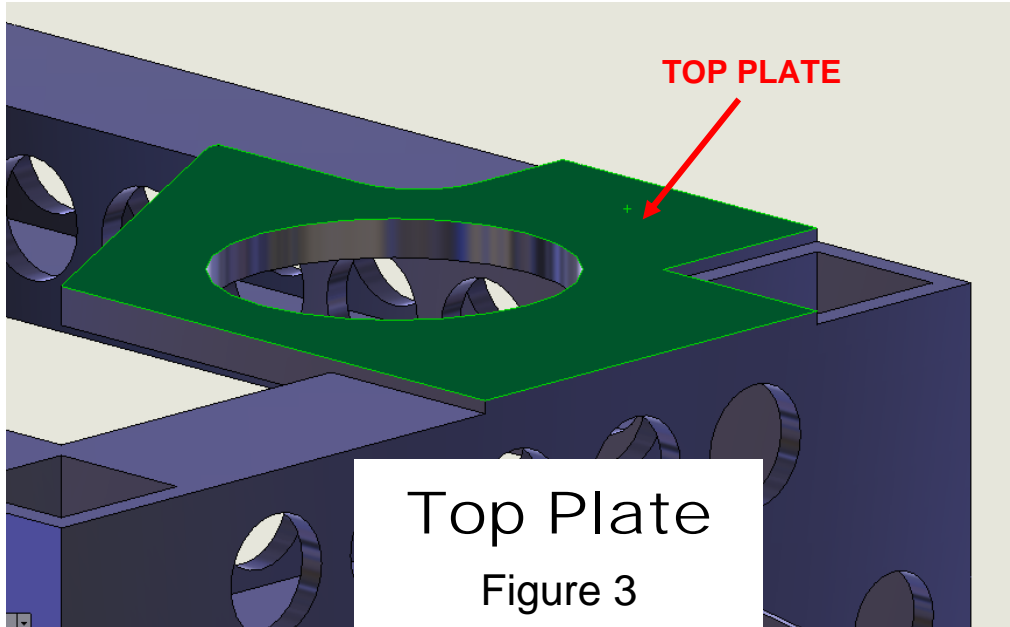

DRAFT

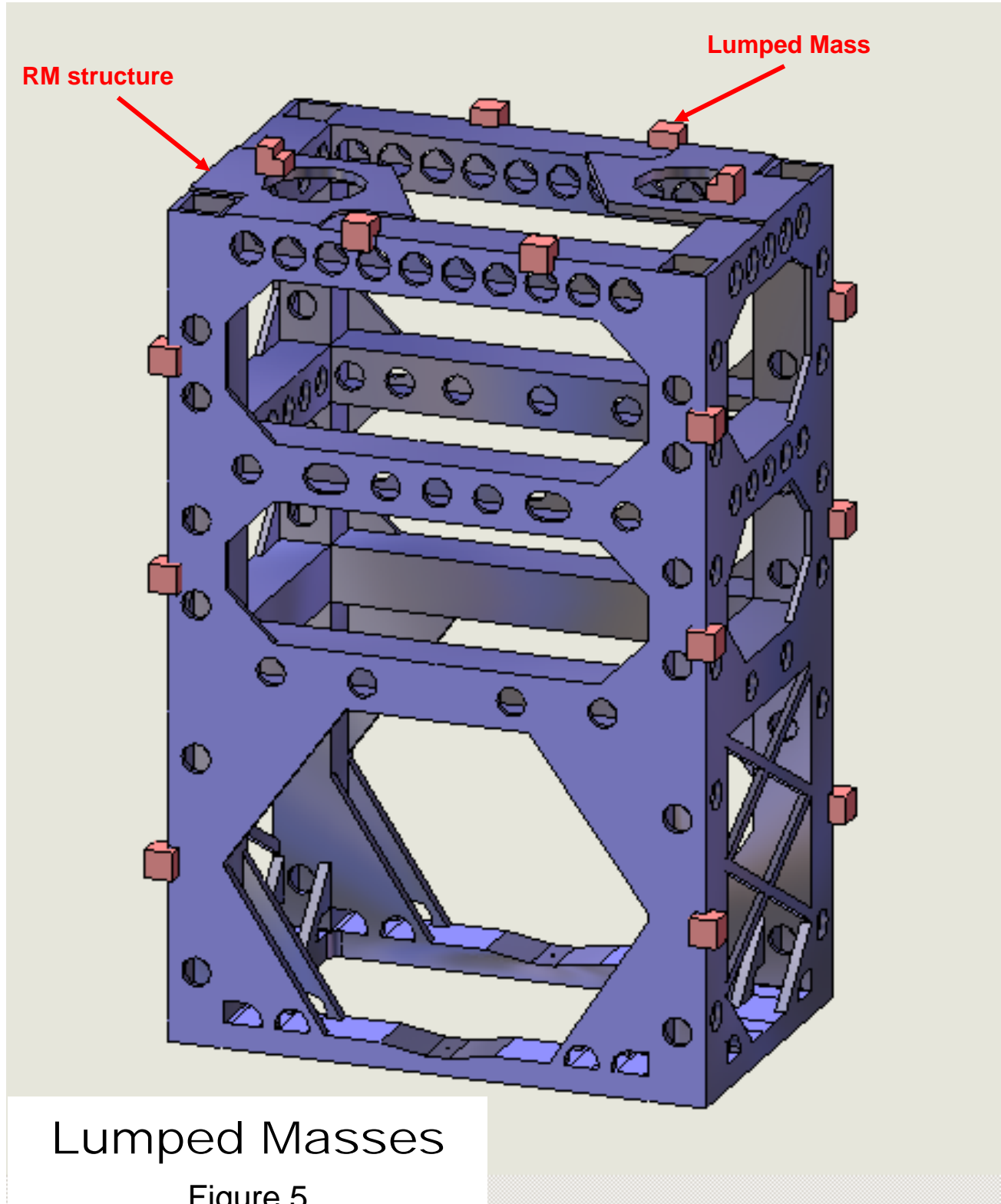

DRAFT

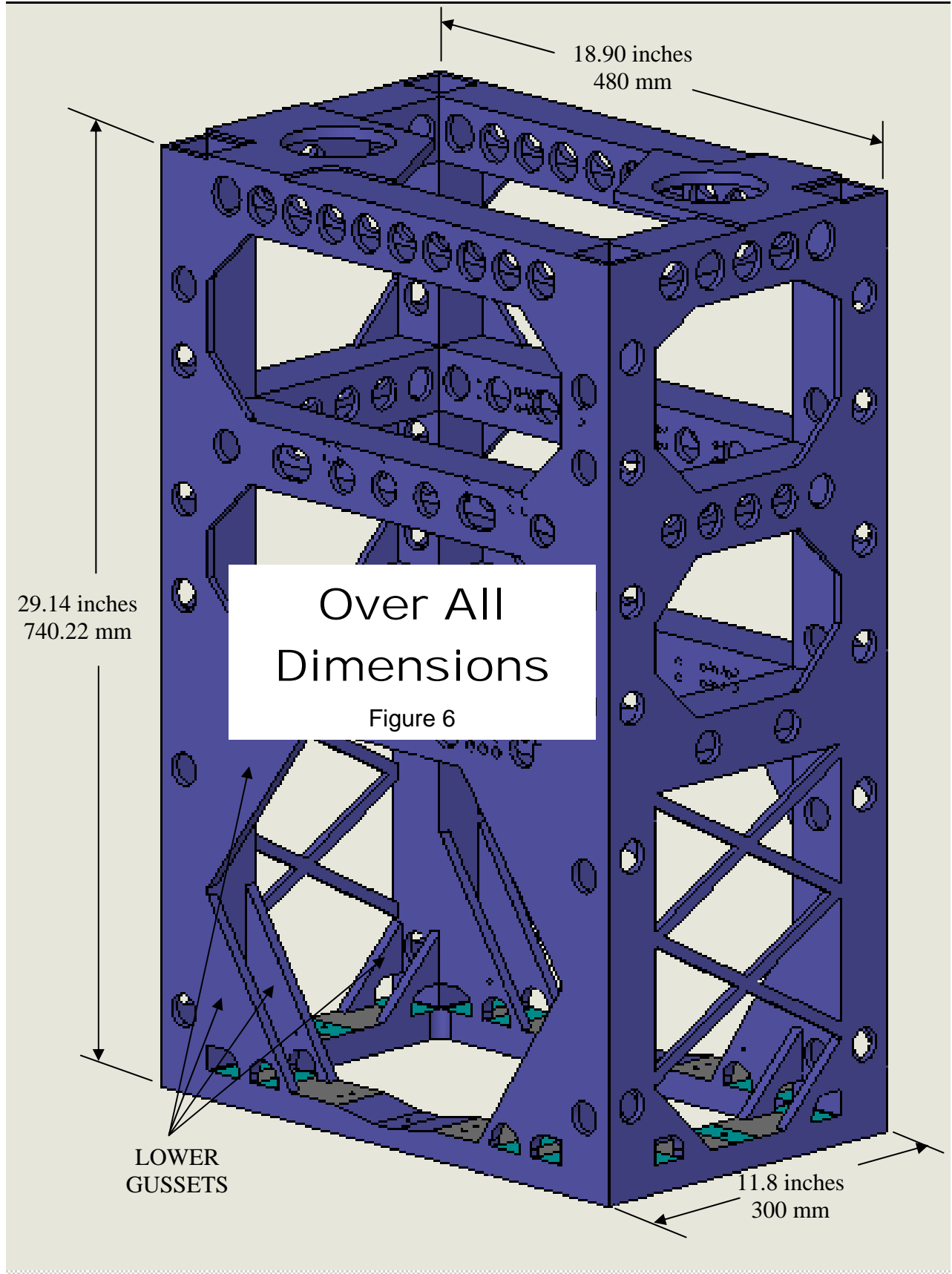

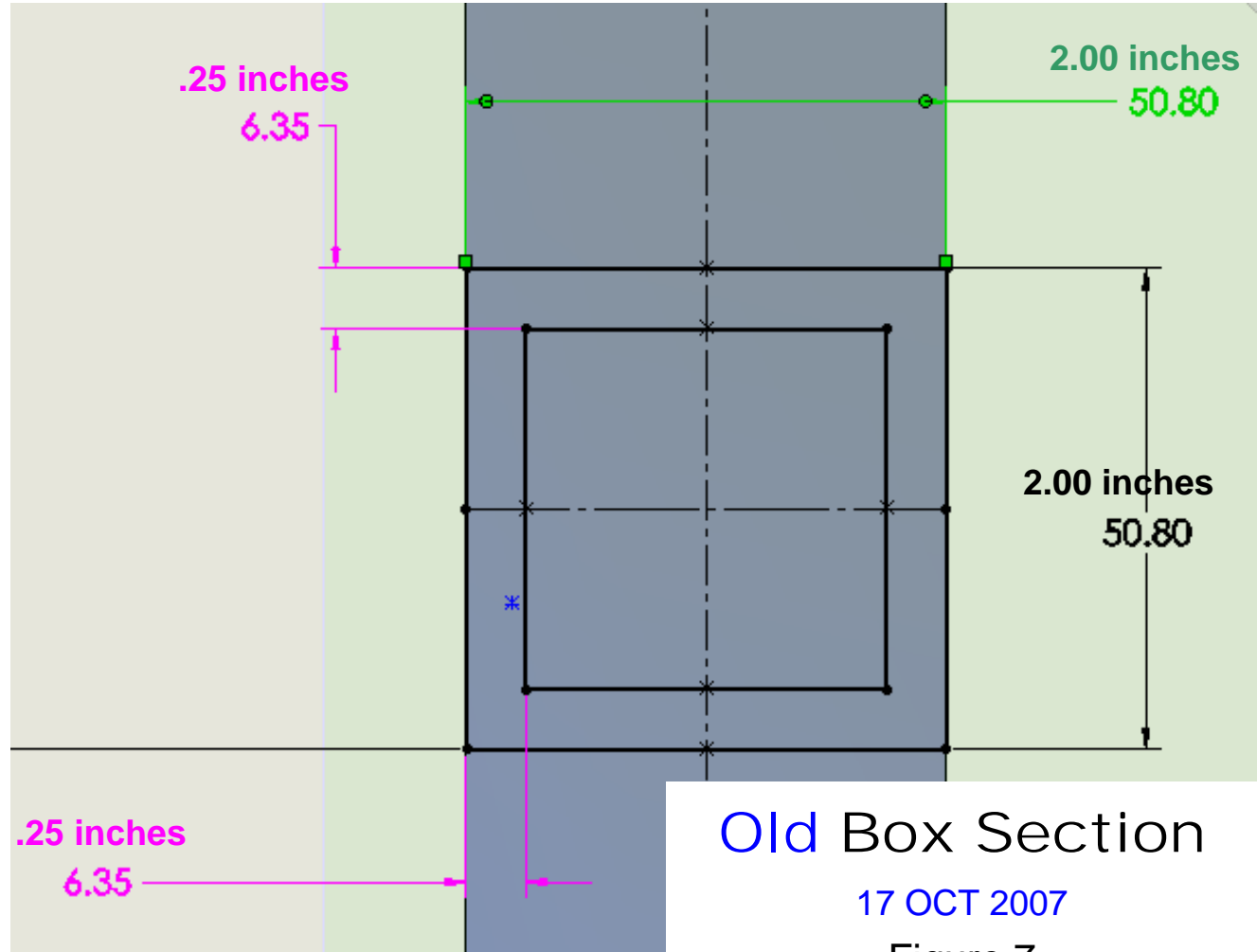
DRAFT

Thickness Of RM Structure updated 24 JUNE 08

- Wall thickness of upper gussets and box sections are 1/4 inch (6.35mm) 17 OCT 2007
- Wall thickness of lower gussets are 3/8 inch (9.53mm) 17 OCT 2007
- box sections with fillets are 1/8 inch (3.17mm) except upper box sections are 3/16 inch (4.76mm) 24 JUNE 08
- Wall thickness of all gussets are 1/8 inch (3.18mm) 24 JUNE 08