

LASER INTERFEROMETER GRAVITATIONAL WAVE OBSERVATORY
- LIGO -

CALIFORNIA INSTITUTE OF TECHNOLOGY
MASSACHUSETTS INSTITUTE OF TECHNOLOGY

Document Type LIGO-T960025-01 - M 3/22/96

**LIGO Computing Systems
Design Requirements Document**

G. Sanders

Distribution of this draft:

Sanders, Lazzarini, Hiscott, Shih, Bork, Kuhnert, Spero, Alt-
house, Lindquist, Raab, Shoemaker, Barish, DCC

This is an internal working note
of the LIGO Project.

California Institute of Technology
LIGO Project - MS 51-33
Pasadena CA 91125
Phone (818) 395-2129
Fax (818) 304-9834
E-mail: info@ligo.caltech.edu

Massachusetts Institute of Technology
LIGO Project - MS 20B-145
Cambridge, MA 01239
Phone (617) 253-4824
Fax (617) 253-7014
E-mail: info@ligo.mit.edu

WWW: <http://www.ligo.caltech.edu/>

TABLE OF CONTENTS

1 INTRODUCTION	5
1.1. Purpose	5
1.2. Scope	5
1.3. Definitions	6
1.4. Acronyms	7
1.5. Applicable Documents	7
1.5.1. LIGO Documents	7
1.5.2. Non-LIGO Documents	7
2 GENERAL DESCRIPTION	8
2.1. Specification Tree	8
2.2. System Perspective	9
2.3. System Functions	9
2.3.1. General Computing System Functions	9
2.3.2. CDS Control and Monitoring System Functions	10
2.3.3. CDS Data Acquisition Functions	10
2.3.4. 40 Meter Computing System Functions	10
2.3.5. System Topology	10
3 COMPUTING SYSTEMS FUNCTIONS AND REQUIREMENTS	12
3.1. Compatibility and Retrievability	12
3.1.1. Hardware Systems	12
3.1.2. Software Systems	12
3.1.2.1 Network Operating Systems	12
3.1.2.2 Workstation Operating Systems	12
3.1.2.3 Developer and Application Software	12
3.2. Cost Effectiveness	13
3.2.1. Capitalization	13
3.2.2. Operating Costs	13
3.2.3. Make or Buy Decisions	13
3.3. Reliability, Maintainability, Availability, Interoperability	13
3.3.1. Standardization	14
3.3.2. Hierarchy of Reliability	14
3.3.3. Maintenance Contracts	14
3.3.4. Redundancy and Failure Response	15
3.3.5. File Backup and Restore	15
3.3.5.1 Mission Critical Backups	15
3.3.5.2 Routine User File Backup	15
3.3.6. Interoperability and Cross Platform Access	16

TABLE OF CONTENTS

3.4. Adoption of Standards	16
3.5. Compatibility with Operating Phase Computing Systems	16
3.6. Quality Assurance	16
3.7. Safety	16
3.8. Computer System and Information Security	16
3.9. Administration, Organization and Reporting	17
3.10. Training	17
3.11. Mobile Computing, Remote Access and Telecommuting	17
4 GENERAL COMPUTING SYSTEMS FUNCTIONS AND REQUIREMENTS	18
4.1. Access to General Computing	18
4.2. General Computing Functions	18
4.3. Information Systems Requirements	18
4.3.1. Text and Technical Document Preparation	18
4.3.2. Electronic Communication	18
4.3.3. File Storage and Retrieval	18
4.3.4. Printing and Plotting	19
4.3.5. Database Functions	19
4.3.6. Spreadsheet Functions	19
4.3.7. Presentation Graphics	19
4.3.8. Internet and Intranet	19
4.3.9. File Transfer Protocol (FTP) Functions	19
4.3.10. Document Control	20
4.3.11. Project Controls	20
4.3.12. Scientific and Engineering General Computing Requirements	20
4.4. General Computing Requirements by Organization	20
4.4.1. Administrative Group Requirements	20
4.4.2. Project Controls Group Requirements	20
4.4.3. Integration Group Requirements	21
4.4.4. Detector Group Requirements	21
4.4.5. CDS Group Requirements	21
4.4.5.1 Overview	22
4.4.5.2 Workstations	22
4.4.5.3 Server	23
4.4.5.4 Software	23
4.4.5.4.1 General	23
4.4.5.4.2 CAD Packages	23
4.4.5.4.3 Database	23
4.4.5.5 Disk Space	23

TABLE OF CONTENTS

4.4.5.5.1 General	23
4.4.5.5.2 Documents	23
4.4.5.5.3 Drawings	24
4.4.5.5.4 Backups	24
4.4.5.6 Peripherals	24
4.4.6. 40 Meter Laboratory Requirements	24
4.4.7. Facility Group Requirements	24
4.4.7.1 Caltech Site	24
4.4.7.2 Observatory Sites	24
4.5. Computation Network Requirements	24
4.5.1. Overview	24
4.5.2. Design Drafting	25
4.5.3. Design Analysis	25
4.5.4. Technical Configuration Management	25
4.5.5. Scientific and Detector Modeling	26
4.5.6. Supercomputer and Parallel/Vector Processor Computation	26
4.5.7. Scientific Data Analysis	26
5 CDS CONTROL AND MONITORING SYSTEM NETWORK FUNCTIONS AND RE-	
QUIREMENTS	27
5.1. Overview	27
5.2. Network	27
5.2.1. Restrictions	27
5.2.2. Bandwidth	27
5.2.3. Media	27
5.3. Workstations	27
5.4. Server	27
5.4.1. Network connections	28
5.4.2. Boot services	28
5.4.3. Software Requirements	28
5.4.4. Disk Space	28
5.4.5. Backups	28
6 CDS DATA ACQUISITION SYSTEM FUNCTIONS AND REQUIREMENTS	29
6.1. Overview	29
6.2. Network	29
6.2.1. Restrictions	29
6.2.2. Media	29
6.3. Servers	29
6.3.1. Requirements	29
6.3.2. Network Connections	29

TABLE OF CONTENTS

7 40 METER LABORATORY COMPUTING SYSTEM FUNCTIONS AND REQUIREMENTS	30
7.1. Scope	30
7.2. Reliability	30
7.3. Safety	30
7.4. User Support	30
7.5. Data collection	31
7.6. Slow Monitoring	31
8 MIT COMPUTING SYSTEM FUNCTIONS AND REQUIREMENTS	32
8.1. General Requirements	32
8.2. Networks	32
8.3. Document Control Center	32
8.4. Scientific and Engineering Databases	32
8.5. Scientific Modeling	32
8.6. Design analysis, design drafting	32
8.7. Data analysis	33
8.8. Network and System Administration	33
8.9. Remote Access	33
8.10. Printing/Plotting	33
9 OBSERVATORY SITE CONSTRUCTION PHASE COMPUTING SYSTEM FUNCTIONS AND REQUIREMENTS	34
9.1. General Computing	34
9.2. Remote and Network Access	34
9.3. Computation and CDS Networks	34
<i>APPENDIX 1 LIGO NETWORK STANDARD</i>	<i>35</i>
<i>APPENDIX 2 LIGO HARDWARE STANDARDS.....</i>	<i>36</i>
<i>APPENDIX 3 LIGO SOFTWARE STANDARDS.....</i>	<i>37</i>
<i>APPENDIX 4 LIGO SPECIALIZED SOFTWARE</i>	<i>38</i>
<i>APPENDIX 5 LIGO COMPUTING SYSTEMS MONITORED ELEMENTS DEFINITION</i>	<i>39</i>

1 INTRODUCTION

1.1. Purpose

This specification establishes the performance and functionality of LIGO Computing Systems during the construction phase of the Laser Interferometer Gravitational Wave Observatory (LIGO).

1.2. Scope

The scope of this specification includes the hardware and software functionality and performance of:

- LIGO General Computing including Information Systems (document control, administrative computing and word processing, cost/schedule and performance measurement systems, cost accounting, procurement systems, property management systems, presentation graphics, electronic communication, World Wide Web service) and Computation (scientific, technical and engineering functions including detector and physics modeling, design analysis, design drafting and configuration management, and scientific data analysis).
- LIGO Control and Data Systems including control, monitoring and data acquisition systems during the construction phase of the LIGO Project.
- 40 m Interferometer data acquisition and analysis systems.
- Observatory site computing systems during the construction period, and prior to installation of the systems to be used during startup and operations and computing systems at MIT.

The scope of this specification is limited to defining the requirements during the construction phase of LIGO. Requirements in this document flow down to the CDS Control and Monitoring Design Requirements Document (LIGO-T950054) and the CDS Data Acquisition Design Requirements Document (LIGO-T960009). However, these documents define requirements extending through the operations phase of LIGO. It is expected that the specifications in this document will be extended to a LIGO Computing Systems Operations Design Requirements Document before commencement of the operations phase.

Expressly excluded from the scope of this specification, and consistent with the CDS systems scope, are:

- LIGO personnel safety systems except that LIGO Computing Systems, specifically the CDS system, may be used to control and monitor hazardous technical systems subject to design and operational safety controls. LIGO Computing Systems must be compatible with the requirements of these design and operational safety controls.
- Facility Control and Monitoring System (FMCS).

1.3. Definitions

Domain Name Service (DNS) -

Fiber Channel (FC) -

File Transfer Protocol (FTP) - A Unix-supported protocol facilitating transfer of files over the internet.

Firewall - A router or other means which serves to prevent external access to internal Project networks. Some LIGO Computing Systems functions are located outside the firewall. These include externally accessible Web pages and File Transfer Protocol (FTP) filespace used to transfer files between the Project and contractors.

Hub -

Integrated Services Digital Network (ISDN) - Digital standard for data transmission over telephone lines at 64 kbps.

Internet Protocol (IP) - The set of standards that define networking over the internet. This protocol specifies transfer of data packets and addressing of nodes on the internet.

Intranet - Internet functionality intended for use within the LIGO Project. This functionality may be available on or isolated from the internet beyond the LIGO firewall.

Legacy Systems - Hardware or software components, systems or standards used in the LIGO Project prior to establishment of this specification and of continuing value to the LIGO Project. These include data and document files, system investments which represent significant financial or resource assets, or technologies required to carry out Project functions. Discarding a legacy system requires a considered and deliberate decision made with awareness of the cost/benefits that result.

Network File Service? (NFS) -

Private Network - A network or subnetwork within LIGO systems with no router connection to the internet external to LIGO systems or to other LIGO networks or subnetworks. A private network cannot access Domain Name Service. A private network is connected to a server on another LIGO network or subnetwork through a dedicated Ethernet interface.

Point to Point Protocol (PPP) - Protocol for transmission of internet packet data over analog serial telephone lines with connections established by dial-in.

Router -

Server -

Switching Hub -

X-window protocol -

LIGO-DRAFT

1.4. Acronyms

1.5. Applicable Documents

1.5.1. LIGO Documents

- LIGO Project Management Plan LIGO-M950001-M
- LIGO Project System Safety Management Plan LIGO M950046-F
- LIGO Science Requirements Document LIGO-E950018

1.5.2. Non-LIGO Documents

- IEEE C95.1-1991 on electromagnetic emissions

LIGO-DRAFT

2 GENERAL DESCRIPTION

2.1. Specification Tree

This document covers the highest level of LIGO computing systems requirements, including all software and hardware components of such systems. This document is shown in perspective to the LIGO requirement specification tree in Figure 1: LIGO Requirement Specification Tree.

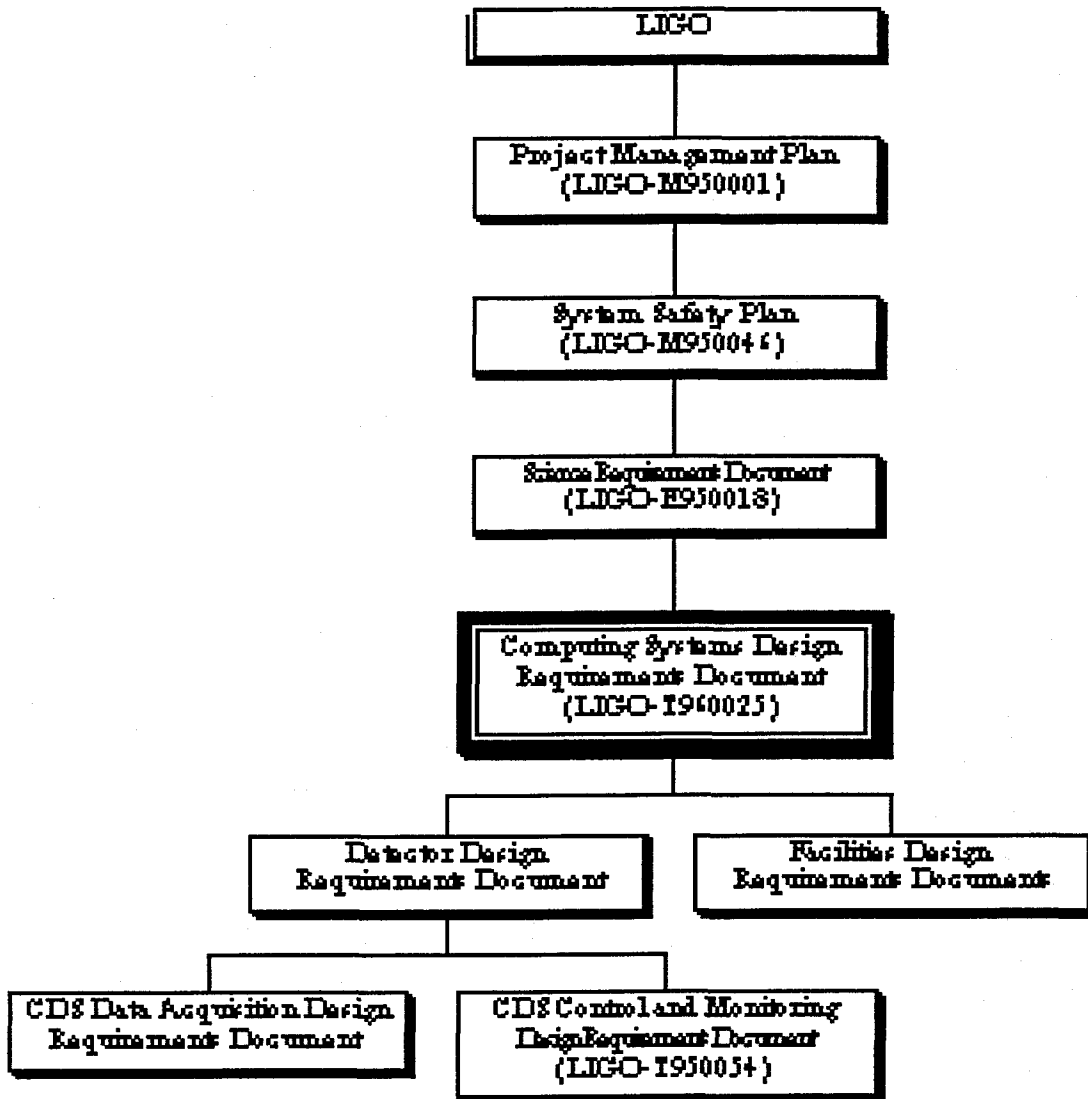

Figure 1: Applicable LIGO Requirement Specification Tree

2.2. System Perspective

LIGO Computing Systems include and incorporate all LIGO software and hardware systems that support LIGO computing, including general computing systems, CDS systems, and 40m interferometer data acquisition and analysis systems. Figure 2 illustrates the relationship, connections and system divisions. These systems include hardware and software at Caltech and MIT, and systems installed at the Hanford and Livingston sites during the construction project phase of LIGO.

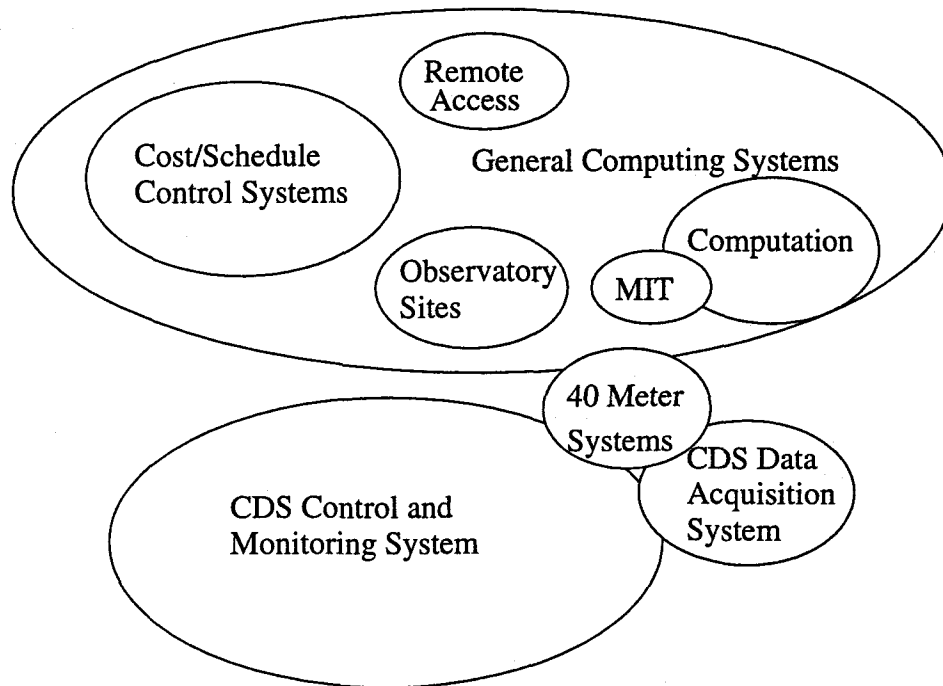

Figure 2: LIGO Computing Systems Perspective

2.3. System Functions

LIGO Computing Systems will support the following functions in a single integrated computer network under unified and coordinated network administration employing compatible standards. The functions include:

2.3.1. General Computing System Functions

- Information systems,
- Computationally intensive scientific, technical and engineering functionality including modeling, design, and data analysis.

2.3.2. CDS Control and Monitoring System Functions

The CDS Control & Monitoring Network shall be a private network that supports LIGO prototype real-time control and monitoring activities, both at Wilson house and the 40M Lab. Its functions shall be executed independently and without interference from or interference with General Computing Systems functions.

2.3.3. CDS Data Acquisition Functions

The CDS Data Acquisition (DAQ) Network provides a private network capability to:

- Test high performance network capabilities
- Prototype and test LIGO data acquisition schemes.

2.3.4. 40 Meter Computing System Functions

The 40 Meter Laboratory requires general computing functions provided by the General Computing Systems, and control and data acquisition functions provided by the CDS Control & Monitoring Network and the CDS DAQ Network. Particular to the 40 Meter Laboratory, however, are requirements for:

- Slow Monitoring of 40 Meter signals,
- Data Acquisition using the Concurrent system.

2.3.5. System Topology

For descriptive purposes, a possible network diagram is shown in the following figure. The several sub-networks at Caltech, the network at MIT, and the initial networks at the observatory sites during construction are shown in a possible configuration.

LIGO-DRAFT

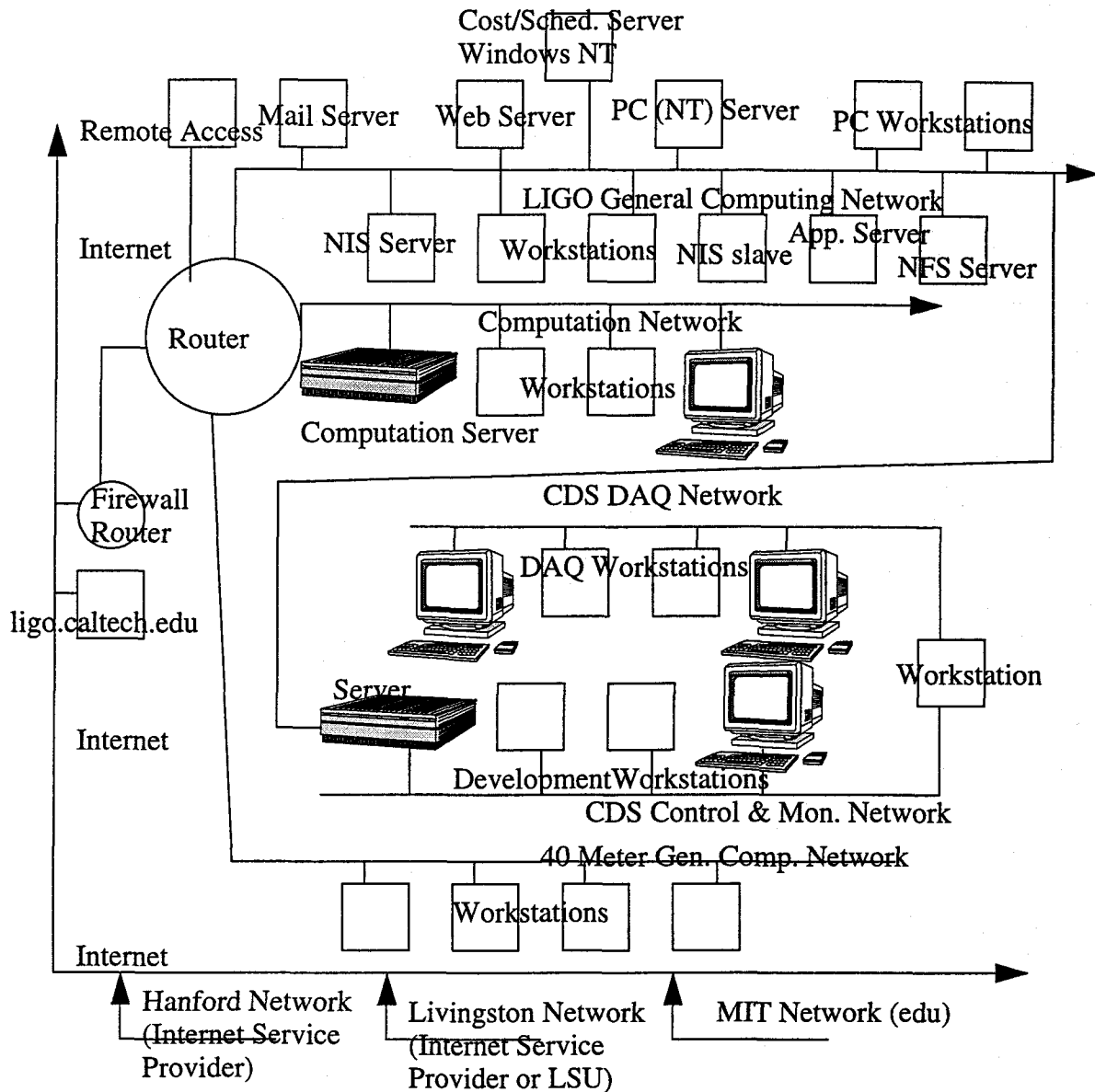

Figure 3: Possible initial construction phase network topology

Schematic above should be considered rough!

LIGO-DRAFT

3 COMPUTING SYSTEMS FUNCTIONS AND REQUIREMENTS

Functions and requirements in this chapter apply to all LIGO Computing Systems discussed in subsequent chapters.

3.1. Compatibility and Retrievability

LIGO has a substantial investment in network hardware, Sun Microsystems workstations and peripherals, legacy software systems and user files created with these software tools, and PC Windows compatible workstations. Backward compatibility and preservation of the investment in legacy hardware and software shall be provided in development of future LIGO Computing Systems.

3.1.1. Hardware Systems

LIGO standardization on Sun Microsystems servers and workstations shall be preserved and future evolution of the network backbone and scientific computing hardware shall be based upon compatible hardware. Individual LIGO servers and workstations on the existing network may be used for different functions, and obsolete elements shall be retired or employed for suitable functions.

3.1.2. Software Systems

3.1.2.1 Network Operating Systems

The network operating system is currently based upon the Sun Microsystems Solaris operating system. LIGO shall continue to employ this operating system and its future versions. LIGO shall not support other Unix operating systems in its networks. This requirement does not preclude simultaneous and concurrent operation of other operating systems linked to the Solaris operating system, such as Microsoft Windows NT or Windows 95 operating through a Winsock-compatible Internet Protocol (IP) including use of X-window and NFS protocols.

3.1.2.2 Workstation Operating Systems

All Unix workstations shall employ the Solaris operating system used by the LIGO network. Exceptions may be made in order to support legacy applications compatible only with precursor operating systems. These exceptions shall be permitted for limited periods of time on individual workstations, with the requirement that legacy applications are replaced within one year with substitutes compatible with up to date LIGO standards.

3.1.2.3 Developer and Application Software

Legacy files shall be preserved. Application software required to make use of legacy files shall be preserved, or, alternately, used to translate all legacy files into formats compatible with replacement applications. Preservation of legacy files in native format, or translation into modern formats, shall be selected based upon importance of the files and the economics of retaining old software licenses. Legacy files need not be preserved in native, editable format. Preservation of output images shall suffice.

3.2. Cost Effectiveness

LIGO Computing Systems serve to accomplish LIGO Project goals and tasks. All system design and acquisition decisions shall be made in a manner to assure cost effectiveness. Use of compatible industry standard commercially available protocols, hardware and software shall be a primary criterion for selecting hardware and software to meet LIGO requirements. LIGO requirements shall be formulated to maximize use of commercial industry standards.

3.2.1. Capitalization

Acquisition of LIGO hardware and software shall be limited to industry standard commercially available choices compatible with LIGO requirements and standards.

LIGO workstations currently consist of two classes of workstation, Sun Microsystems Unix workstations, and Microsoft Windows compatible PC workstations (desktop and laptop varieties). New workstations shall be selected from these two classes only. The default LIGO standard workstation shall be a PC workstation with Unix network access through X-window software permitting full NFS capability. Sun Unix workstations shall be selected only when computationally intensive scientific, engineering and technical work comprises a major fraction of a staff member's assignment. Each staff member in LIGO shall be assigned a single workstation.

3.2.2. Operating Costs

All LIGO Computing System acquisitions shall be made in a manner to optimize life cycle costs. Operating costs such as maintenance contracts, license renewals, upgrade fees and training costs shall be explicitly identified at time of acquisition. Concurrent or floating software licenses shall be used to minimize software license costs.

3.2.3. Make or Buy Decisions

Proposals to carry out in-house or contracted development of hardware or software tools shall include explicit consideration of commercially available industry standard solutions to LIGO requirements. All Make or Buy Decisions involving costs expected to exceed \$50,000 shall require review by the LIGO Technical Board.

3.3. Reliability, Maintainability, Availability, Interoperability

LIGO Computing Systems must have high reliability and availability. Network server and router reliability must be very high and statistics shall be continuously collected on all router and network server reliability and reported monthly to LIGO Project Management in a LIGO Computing Monthly Report.

Reliability, maintainability and availability (RMA) shall be accomplished by standardization and appropriate combination of maintenance contract response and LIGO redundancy and failure response time

Workstation setups shall be cloned from a single standardized setup established for Unix and Windows PC workstations.

3.3.1. Standardization

In order to promote reliability, maintainability and availability, LIGO shall adopt standard hardware and software tools to be supported by the network administration team. When required by a special need, specialized hardware and software adopted in exception to LIGO standards shall be supported and maintained by the specific LIGO organization responsible for satisfying the specialized need. Appendices 1-4 list existing de facto LIGO standards. These standards are adopted as a baseline requirement for future system definition and evolution.

3.3.2. Hierarchy of Reliability

Reliability and availability shall be assured with the following priority:

1. major network router
2. network cable plant
3. primary NIS, NFS and mail servers
4. application servers
5. other servers and backup routers
6. auxiliary network hardware
7. individual workstations
8. individual peripherals

3.3.3. Maintenance Contracts

All mission-critical LIGO Computing Systems network hardware and software shall be operated under maintenance contract. Hardware with lower priority shall be under contract if deemed cost-effective. Contract response times shall be required according to the following:

Table 1: Maintenance Contract Response Time Requirements

<i>System Element</i>	<i>Response Time (hours)</i>
major network router	TBD
network cable plant	N/A
primary NIS, NFS and mail servers	4
application servers	TBD
other servers and backup routers	TBD
auxiliary network hardware	N/A
individual workstations	N/A
individual peripherals	N/A

3.3.4. Redundancy and Failure Response

Critical network elements shall be provided with redundancy. Main router and NIS/NFS servers shall have alternates. Allowed recovery times include the time to install a backup hardware element, or restore backup files, and to test the recovered element. Total elapsed times for workday recovery from network element failures shall be:

Table 2: Redundancy and Workday Failure Recovery Time Requirements

<i>System Element</i>	<i>Redundant</i>	<i>Workday Recovery Time (hours)</i>
major network router	yes	2
primary NIS server	yes	2
primary NFS server	yes	2
mail server	yes	2
application server	TBD	4
PC NT server	TBD	TBD

Evening, holiday and weekend recovery times shall be TBD.

3.3.5. File Backup and Restore

The Unix network shall provide for periodic backup of all files in the shared network file system. New disks and file space additions to the system shall be incorporated into the backup processes at the time of introduction to the system. Backup of local workstation drives shall be supported, but not required.

3.3.5.1 Mission Critical Backups

Network operating systems, applications critical to operation of LIGO scientific hardware, and mission critical databases shall be backed up daily. Daily backups shall be incremental and redundant so as to insure reconstruction of mission critical files. Full backups shall be carried out at least monthly.

3.3.5.2 Routine User File Backup

Non critical application and user files on the shared network filespace shall be backed up at least semi-weekly.

3.3.6. Interoperability and Cross Platform Access

Nonscientific and nontechnical mission critical functions such as word processing, presentation graphics, electronic mail, document database, appointment calendars and network file access shall be fully functional from both Unix workstations and Windows PC's. This shall be accomplished through the use of X-window software and intranet Web access using Web browser software. Standard Unix applications shall be accessible from Windows PC's. Computational tools for use in scientific and technical functions, native to the Unix environment, shall be supported on the Unix platform primarily, and access through Windows PC's shall be provided if feasible. Applications of this type may include MATLAB, AVS, Mathematica, Code V, IDEAS, CADENCE, EPICS, etc.

3.4. Adoption of Standards

All network, hardware and software elements supported by the LIGO Computing Systems network administration team shall be standardized. Adoption of standards shall be accomplished by review of the proposed standard by the LIGO Computing Committee and action on the Committee recommendation by the Project Manager. Legacy standards are listed in Appendices 1-4.

3.5. Compatibility with Operating Phase Computing Systems

LIGO Computing Systems installed and utilized during LIGO construction shall be designed, selected and implemented to be fully compatible with LIGO operating phase computing systems.

3.6. Quality Assurance

The performance, utilization and availability of LIGO Computing Systems shall be monitored and documented in a monthly LIGO Computing Systems usage report. Monitored quantities are defined in Appendix 5. A performance target shall be established for each monitored element.

3.7. Safety

The LIGO ES&H Officer shall review this document and all planned major modifications to LIGO Computing Systems for possible hazards, noncompliance with established Standard Operating Procedures, and conformity to the requirements of the LIGO System Safety Plan. LIGO Computing Systems shall not be responsible for Personnel Safety functions. However, they may provide the means to collect safety related status information and the means to make control inputs. These functions may have safety consequences requiring review and approval.

3.8. Computer System and Information Security

All LIGO Computing Systems shall be protected through individual passwords supported by the NIS features of the operating system. LIGO Computing Systems shall operate in an otherwise open manner as is expected for a publicly supported research computing system. The system shall be monitored for security breaches. Use of more restrictive security measures shall require review by the Computing Committee and approval by the Project Manager. LIGO shall maintain an

open, public Web server providing introductory information, news releases, all scientific and technical documents approved for public release, LIGO Research Community information, and contact information. An internal Web server shall support internal Project information and administrative information.

3.9. Administration, Organization and Reporting

A single Network Administration Team shall service and support all LIGO Computing Systems. This Team shall be part of the General Computing Group in the Integration Group in the LIGO Project Office. The Network Administration Team shall be responsible for the efficient and functional operation of all LIGO Computing Systems. It shall be tasked to meet the needs of its customers. All license administration shall be carried out in the LIGO General Computing Group. Configuration Control of the LIGO Computing Systems shall be administered by the General Computing Group. The Computing Committee shall review all significant changes proposed to the configuration. Approval of changes shall be made by the Project Manager.

3.10. Training

LIGO shall support training for LIGO staff in the use of LIGO Computing Systems. The LIGO internal Web server and Usenet newsgroups shall provide primary reference and support information and access. Classroom training and use of multimedia training materials shall be encouraged.

3.11. Mobile Computing, Remote Access and Telecommuting

LIGO shall provide laptop computers to staff requiring mobile computing capability as part of job functions. The laptop computer shall be the single computer for the designated staff member. Approval by the Project Manager of assignment of a laptop shall be required.

Computing from home shall be supported by LIGO through provision of a modem and standard access software. No home computing will be supported by assignment of a fixed computer at home. Home computing shall be accomplished by use of a mobile laptop or the staff member's personally owned computer. A LIGO policy on home computing shall be established in writing and maintained as a controlled policy.

All use of mobile and home computing tools shall be carried out under a strict property management policy administered by the General Computing Group.

LIGO shall maintain adequate dial-in capabilities supporting ANSI standard terminal sessions and Point-to-Point Protocol (PPP) access. ISDN access will be supported with adequate justification and shall require approval by the Project Manager. General Computing Group support of home connections shall be limited. Dial-in PPP and ISDN access shall be to a server separately connected to the General Computing primary router to facilitate a separate pool of IP numbers for remote access.

All remote access shall enable General Computing Systems functionality. Remote access to the CDS Control & Monitoring, CDS DAQ or 40 Meter Networks shall require approval of the Project Manager and review by the LIGO Safety Officer.

4 GENERAL COMPUTING SYSTEMS FUNCTIONS AND REQUIREMENTS

4.1. Access to General Computing

All LIGO staff shall be provided with access to LIGO Computing Systems. A single computer or workstation shall be individually assigned to each staff member to facilitate this access.

4.2. General Computing Functions

- Information systems
- Scientific, technical and engineering functionality including modeling, design, and data analysis

4.3. Information Systems Requirements

Information systems include administrative databases, contact management, cost accounting, procurement actions, property management, presentation graphics, document control, text and technical document preparation, electronic communication, distribution of public LIGO information and documents, forms management and personnel management. Tools and hardware platforms adopted for these functions shall be industry standards suitable for a general business environment and should be accessible to non-specialists. Text and document processing tools should be accessible to staff carrying out general business document preparation as well as to those preparing scientific documents. This will require operability on both scientific and office workstations.

4.3.1. Text and Technical Document Preparation

All LIGO text and technical documents shall be prepared with the LIGO standard software, Adobe FrameMaker. This tool operates in a fully compatible manner on LIGO Unix and Windows workstations. LIGO shall provide no support for other text or word processing software. Legacy documents prepared with obsolete tools shall be treated in accordance with the requirement of Section 3.1.

4.3.2. Electronic Communication

All LIGO staff shall be provided access to an electronic mail account. The LIGO General Computing System shall provide for a Unix-based mailserver supporting the SMTP and POP3 protocols. LIGO General Computing shall provide support only for the standardized LIGO mail tools listed in Appendix 3. All LIGO mail files on shared drives shall be included in system backups.

4.3.3. File Storage and Retrieval

A single network file space shall be provided to support all LIGO General Computing. It shall be based upon the Unix file standards and shall be served using the NFS protocol. All LIGO Unix and Windows workstations shall be provided with NFS capability to provide access to the file space. The file space shall permit retrieval from any LIGO workstation. The LIGO file space shall

be fully mounted through the Windows operating system on LIGO PC's. Each LIGO staff member shall have access to 0.10 GByte disk space for General Computing user files.

4.3.4. Printing and Plotting

All LIGO workstations shall have access to all networked printers and plotters. Black and white postscript, color postscript, HP PCL, and HP GL protocols shall be supported on one or more of the LIGO network printers in formats A through E.

4.3.5. Database Functions

LIGO shall support a single standard database tool for all General Computing database functions. Access to this database shall be facilitated on all workstations with connection to the General Computing System network. This standard software shall also be the default tool for database needs on other portions of LIGO Computing Systems. Specialized database tools will be supported according to the policy in Section 3.3.2.

4.3.6. Spreadsheet Functions

LIGO shall support a single standard spreadsheet tool for all General Computing spreadsheet functions.

4.3.7. Presentation Graphics

LIGO shall support a single standard presentation graphics tool. In order to assure interchange of presentation graphics, the LIGO standard text processing tool, Adobe FrameMaker, is adopted as the standard.

A gallery of presentation graphics shall be established and maintained on the LIGO General Computing Network. Together with hard copy graphics archived in the Document Control Center, this electronic gallery will facilitate accuracy and completeness of LIGO presentations and publications. The gallery shall be accessible from all General Computing workstations regardless of platform. This shall be accomplished by use of a thumbnail gallery on the LIGO Web server which provides for multiformat downloading through a Web browser.

4.3.8. Internet and Intranet

Internet, LIGO intranet and World Wide Web functionality shall be fully supported and exploited to make LIGO information systems accessible on a platform-independent basis. LIGO Web server capability shall support both publicly accessible Web files, and Web files accessible only within the LIGO Project.

4.3.9. File Transfer Protocol (FTP) Functions

LIGO shall maintain a File Transfer Protocol Server accessible from the public internet to facilitate file exchange with contractors and collaborating institutions.

LIGO-DRAFT

4.3.10. Document Control

General computing shall provide the capacity and equipment means for electronic storage, indexing and full electronic access (by any authorized workstation) of significant LIGO documents whether or not an electronic source document is available, and regardless of whether the document is produced internally, by LIGO subcontractor, or is acquired (such as user's or service manuals for commercially acquired equipment). Document storage on disk will require 10 MByte disk capacity.

4.3.11. Project Controls

Cost/schedule and performance measurement systems shall include database storage of work breakdown structure definition, cost estimate detail, cost baseline, schedule baseline and performance measurement baseline. Support shall be provided for extensive graphical and tabular reporting of Pert charts, Gantt charts, and cost/schedule performance reports. The system shall provide support for system update, query and editing simultaneous with support of plotting and printing of reports. Color plotting up to E-size format shall be supported. Software tools shall be accessible industry standard tools suitable for a project of the scale of LIGO and may require expert operators to enter, manipulate and structure cost and schedule plans and reports. Disk file storage for the cost/schedule function shall be TBD GByte.

The cost/schedule function requires a very high reliability database server. This shall be provided by a Microsoft Windows NT server which isolates client workstations from the Unix network. The cost/schedule function shall be accomplished with standard applications. These applications are the FoxPro 2.6 relational database underlying Open Plan, Cobra and Open Plan Professional which are used to create and manipulate the Project Management Control System (PMCS).

4.3.12. Scientific and Engineering General Computing Requirements

Scientific graphics and equation typesetting shall be supported with tools compatible with the general administrative support tools to facilitate Administrative Group support of scientists and engineers.

4.4. General Computing Requirements by Organization

4.4.1. Administrative Group Requirements

Administrative Group requirements are included in Information Systems Requirements.

4.4.2. Project Controls Group Requirements

Project Controls Group requirements are included in Information Systems Requirements, with emphasis on Project Controls. The Project Controls Group shall be connected directly to the Caltech IFIS system to facilitate management of procurements and cost accounting.

LIGO DRAFT

4.4.3. Integration Group Requirements

Integration Group Requirements are included in Information Systems Requirements, and in Computation Network Requirements.

4.4.4. Detector Group Requirements

Detector Group Requirements are included in Information Systems Requirements, Computation Network Requirements, CDS Group Requirements, and 40 Meter Laboratory Requirements.

4.4.5. CDS Group Requirements

The CDS Group will require support on three networks during the construction phase. The general relationship of the CDS Group requirements to LIGO Computing Systems is outlined in the following figure.

LIGO-DRAFT

Figure 4: CDS Group Network Connections and Relationship to General Computing

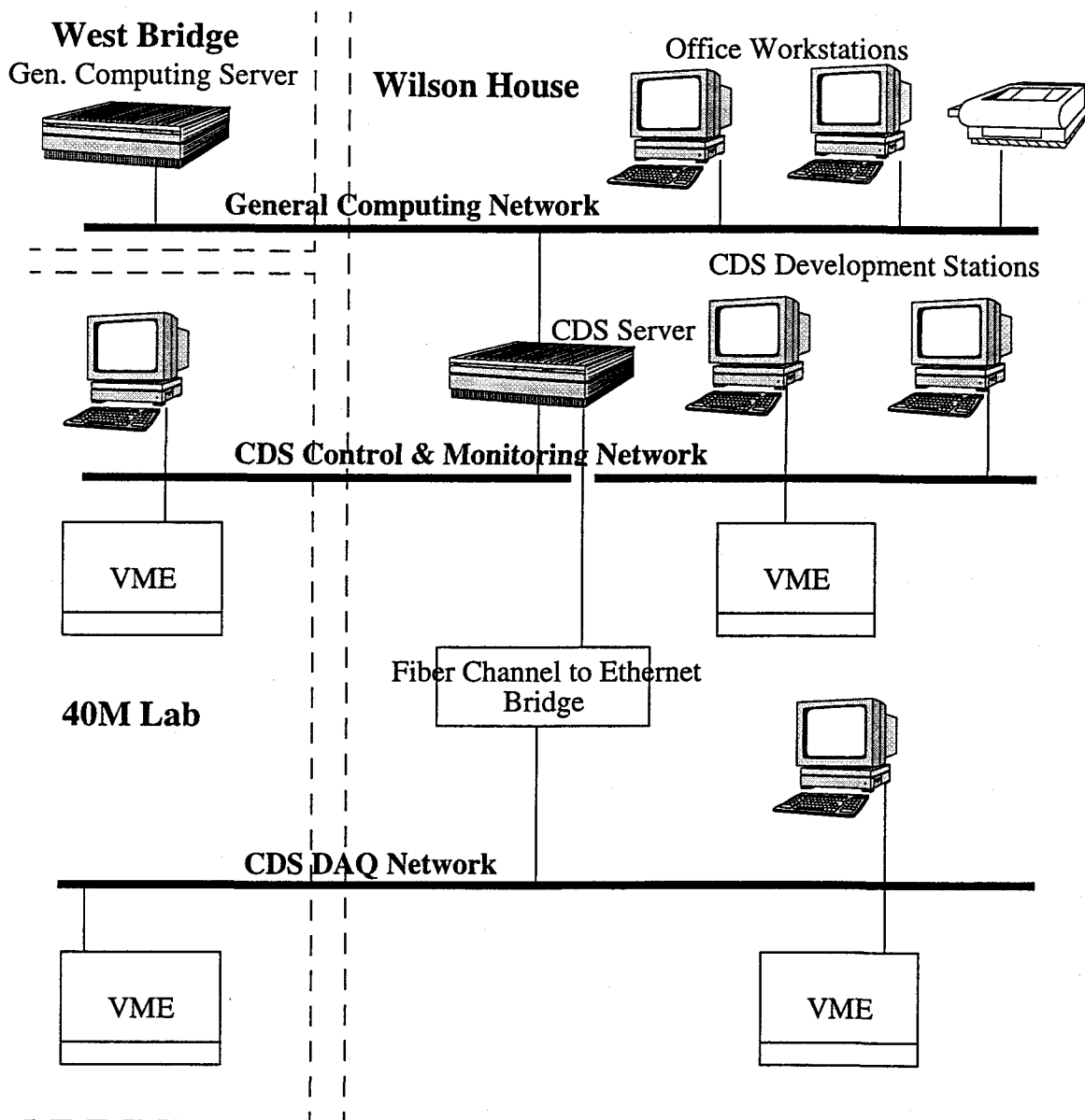

4.4.5.1 Overview

The CDS group staff requires General Computing support, such as word processors, spreadsheets, and CAD packages. These functions shall be carried out on workstations independent of the the CDS Control & Monitoring and DAQ Networks.

4.4.5.2 Workstations

The CDS group requires software tools that operate on PCs and tools that operate on Unix workstations.

4.4.5.3 Server

A server (Gen. Computing Server in Figure 4) shall be provided to support the general computing requirements of the CDS group, as defined in the remainder of this section. This server may be solely assigned to the CDS Group, or be a General Computing server shared across LIGO General Computing. In addition to supporting CDS General Computing functions, it shall provide Cadence license service to the CDS Group and to the entire Caltech campus.

4.4.5.4 Software

4.4.5.4.1 General

The CDS Group requires access to all LIGO standard software, such as Frame, and standard software tools, such as mail, calendar, etc., for both Unix and PC workstations.

4.4.5.4.2 CAD Packages

The CDS Group requires two CAD packages:

- Cadence, for electronic schematic capture, board layouts and modelling
- AutoCad, for system layouts and wiring diagrams

Cadence runs under Solaris on Sun stations. CDS Group Cadence licenses are also being used by other Caltech departments. Thus, the server which supplies Cadence license service must have access to the Caltech network, either directly or through a router.

4.4.5.4.3 Database

The CDS Group requires database functionality for control, monitoring, data processing and component tracking.

Work to date (limited prototyping efforts) has been done using MS Access. If MS Access is adopted as the LIGO standard, then the CDS Group will require a networked PC server to allow Unix system access (via X server or similar software), if the LIGO project requires database access from Unix stations. At minimum, even if only PCs are required access, networked file space will be required.

If Oracle becomes the standard, the CDS Group will require that, at minimum, the remaining components of Oracle be installed on a networked server and some Database Administration services be provided. Once this is done, the Oracle 7.1 tools would be evaluated for ease of use and productivity, with, perhaps, a resulting need for additional third party tools.

4.4.5.5 Disk Space

4.4.5.5.1 General

Each CDS staff member requires 1GByte space for general files and software. These file spaces shall be included in LIGO Computing Systems backup facilities.

4.4.5.5.2 Documents

The CDS Group requires 10 GByte of file space for storage of documentation.

4.4.5.5.3 Drawings

15 GByte of disk space will be required for storage of drawings.

4.4.5.5.4 Backups

The CDS Group requires tape backup of all disks supporting CDS general computing. This backup support shall be provided by a General Computing server.

4.4.5.6 Peripherals

Due to the physical separation of the CDS Group at Wilson house, the Group requires separate printing and plotting facilities.

4.4.6. 40 Meter Laboratory Requirements

The requirements of the 40 Meter Laboratory are included within the requirements of Information Systems and in Computation Network requirements. Due to physical remoteness from other LIGO sites at Caltech, the 40 Meter Laboratory requires printing capabilities suitable for color display of scientific data.

General Computing workstations at the 40 Meter Laboratory shall not be capable of exercising control, monitoring or data acquisition functions, nor shall they be affected by these functions carried out on other subnetworks such as the CDS subnetworks.

LIGO staff working for significant fractions of the time at the 40 Meter Laboratory shall have access to General Computing capabilities at the 40 Meter Laboratory. This shall be in addition to the single workstation assigned to each staff members office location. This shall be accomplished in a cost effective manner.

4.4.7. Facility Group Requirements

4.4.7.1 Caltech Site

Facility Group requirements are included in Information Systems and Computation Network requirements.

4.4.7.2 Observatory Sites

During construction, Facility Group shall be provided with General Computing workstations, printing capability, and PPP or ISDN access to the Internet in order to assure network communication with the Caltech and MIT LIGO sites. Other requirements shall be equivalent to LIGO General Computing requirements.

4.5. Computation Network Requirements

4.5.1. Overview

The LIGO General Computing System shall include a separate subnetwork to isolate and support computationally intensive activities. The Computation Network shall include a Computation Server with sufficient computing power to minimize the requirement to run intensive codes on

client workstations. The Computation Network shall have adequate file space to support large data files and design files. The Computation Network shall not be a private network, as it shall serve General Computing functions for LIGO staff assigned to the Computation Network. LIGO staff whose job assignment includes operating computationally intensive codes as a significant fraction of their assignment shall be provided with a General Computing workstation connected directly to the Computation Network so that network traffic related to intensive tasks need not be passed across the primary router.

Scientific, technical and engineering functionality shall include computationally intensive physics and detector modeling, mechanical, thermal and electronic design analysis, design drafting, technical configuration management, and scientific analysis of data collected with the 40 Meter Laboratory or other LIGO scientific instrumentation. Analysis and archiving of scientific data will be supported in a distributed and collaborative manner. Hardware and software tools will be selected to be appropriate for the performance demands of the application, but use of cost-effective industry standard tools will be encouraged. Selection of specialty tools will be made when performance requirements eliminate more cost-effective standard solutions. LIGO scientific computing will be conducted in a standardized environment accessible to LIGO staff and collaborators and organized in a software engineering environment that supports integration of code modules authored by collaborators.

4.5.2. Design Drafting

LIGO design drafting shall be performed on Unix workstations and Windows PC's. The LIGO standard computer aided drafting (CAD) tool shall be IDEAS, operating on the Unix network. IDEAS provides LIGO's primary design analysis capability as well, with support for finite element analysis. Auxiliary design drafting for overall layout, management of design integration, "sketch" drafting, drawing interchange with contractors and primary drafting of electrical and cable plant layouts shall be performed on Autodesk AutoCAD, which operates in both Unix and Windows PC versions.

Staff performing design drafting will require TBD disk file space for storage of drawings. Color monitors with high resolution shall be provided for design drafting.

The primary plot device shall be available to all workstations on the Computation Network.

4.5.3. Design Analysis

The Computation Network shall provide sufficient computational power to support finite element modeling in support of LIGO detector design. Computational power shall be provided by the Computation Server.

4.5.4. Technical Configuration Management

Computation Network shall provide sufficient disk file space to support maintenance of a controlled ensemble of configuration drawings and specifications.

LIGO-DRAFT

4.5.5. Scientific and Detector Modeling

Computation Network shall provide support for development of modeling codes in Fortran and C and integration of code modules in the AVS environment. Computational power shall be provided by the Computation Server.

4.5.6. Supercomputer and Parallel/Vector Processor Computation

LIGO will require access to the Caltech CACR Intel Paragon supercomputer to support running codes that exceed the computational power of the LIGO Computing Systems. LIGO General Computing shall support required access to the Paragon.

4.5.7. Scientific Data Analysis

LIGO data analysis shall be primarily conducted on the Computation Network.

LIGO-DRAFT

5 CDS CONTROL AND MONITORING SYSTEM NETWORK FUNCTIONS AND REQUIREMENTS

5.1. Overview

The CDS Control & Monitoring Network shall be a private network for LIGO prototype real-time control and monitoring activities, both at Wilson house and the 40 Meter Laboratory. General Computing functions will not be supported on the CDS Control & Monitoring Network.

5.2. Network

5.2.1. Restrictions

No LIGO General Computing traffic, such as file and peripheral services, are to be allowed onto this network. It shall not be connected to the LIGO General Computing networks through a direct connection, switch or router. The only connection to the General Computing network shall be through a CDS server which shall not interfere with the General Computing network (see following sections.)

5.2.2. Bandwidth

Standard ethernet will provide the performance necessary for prototype development anticipated through the construction phase.

5.2.3. Media

The CDS Network presently uses a fiber optic link to connect Wilson and the 40 Meter Laboratory for the CDS Network. Bridges with 10baseT connections are on either end, and these will meet requirements during LIGO construction .

5.3. Workstations

At present, two workstations reside on the CDS network: one at Wilson for code development and operator display services, and one (with two monitors) at the 40 Meter Laboratory to serve as an operator console for the PSL and, in the future, for recycling. One laptop PC is also on the net, for local operation of the PSL. In the future, a minimum of two more Sparc5 equivalent workstations will be required to support development/prototype tests on this network.

5.4. Server

A dedicated server is required to support CDS real-time control and monitoring and DAQ prototype activities. This server is indicated in Figure 4. If Access is adopted as the database of choice, a Windows PC server will be required for EPICS development and real-time database downloading.

5.4.1. Network connections

The CDS server requires separate access to the CDS Network, DAQ Network and LIGO General Computing Network. This server and its network connections shall not be used for general network routing. The connection to the LIGO General Computing Network is to be used solely for:

- Downloading new/updated software.
- Serving "view only" operator displays, via X windows, to a strictly limited number of office workstations.
- Access to printers, by the server, on the LIGO General Computing Network.
- Serving data acquisition files from the DAQ to limited General Computing Computation Network workstations.

5.4.2. Boot services

The CDS server shall provide all operating system boot services for:

- Unix workstations assigned to this network for code development and for use as operator consoles.
- All real-time VME processors used in prototype and 40 Meter systems running under VxWorks.

5.4.3. Software Requirements

The CDS server shall provide all software as necessary for CDS Control & Monitoring systems at Caltech. It explicitly shall not provide mail and calendar tools, web browsers, and the like, which could result in use of the CDS or DAQ network for purposes other than control activities.

5.4.4. Disk Space

A minimum of 10GBytes disk space is required.

5.4.5. Backups

A backup tape unit will be required to back up all CDS Network disk drives.

LIGO-DRAFT

6 CDS DATA ACQUISITION SYSTEM FUNCTIONS AND REQUIREMENTS

6.1. Overview

The CDS DAQ Network will be a Fiber Channel (FC) fabric, intended solely for use to:

- Test high performance network capabilities
- Prototype and test LIGO data acquisition schemes.

All equipment and software for this network will be provided by the CDS Group under DAQ prototyping funds. This being the case, and the fact that access/connection to this network is restricted, it places very few requirements on LIGO General Computing facilities.

6.2. Network

6.2.1. Restrictions

No LIGO General Computing traffic, such as file and peripheral services, are to be allowed onto this network. It shall not be connected to the LIGO General Computing networks through a direct connection, switch or router. The only connection to LIGO General Computing Network will be through a CDS server.

6.2.2. Media

Fiber Channel (FC) requires multi-mode fiber optic cable. For testing of the network and data acquisition, it is desirable to run this network to the 40 Meter Laboratory from the Wilson house. This requires a fiber optic pair. Also, since the fiber run from Wilson to Bridge is single mode and the connecting run from Bridge to the 40 Meter Laboratory is multi-mode, a single mode to multi mode transition module will be required, along with space to mount it at Bridge. A similar transition would be installed at Wilson.

6.3. Servers

6.3.1. Requirements

Server requirements for this Network are included in the scope of and would be met by the previously defined CDS Server.

6.3.2. Network Connections

A FC/Ethernet bridge is required to connect the DAQ Network processors with the CDS server.

LIGO-DRAFT

7 40 METER LABORATORY COMPUTING SYSTEM FUNCTIONS AND REQUIREMENTS

7.1. Scope

The functions and computing systems supporting these functions at the 40 Meter Laboratory include:

- Interferometer control and monitoring (PSL, slow monitor, other controls to be added) provided by the CDS Control & Monitoring Network
- Vacuum system control provided by the CDS Control & Monitoring Network
- Data collection and real-time data analysis provided by the CDS DAQ Network
- General user support software and hardware provided by General Computing Systems.

Specific requirements for these functions are included elsewhere in this specification in the discussion of each computing system.

7.2. Reliability

High availability of the 40 Meter Interferometer is required. The CDS Control & Monitoring System control computers and network connections shall support system reliability. The following failure rates and repair times will meet this requirement. Assuming round-the-clock operation,

- MTBF > 1 month
- MTBF / MTTR > (1 month) / (6 hr), i.e. availability > 99%

We note that one factor affecting reliability is the number of computers and network connections that are required for operation. For example, the PSL alone requires two computers outside of the 40 Meter Laboratory (CDSSOL2 and kater) to work.

7.3. Safety

The interferometer, including the laser, should be controlled only by personnel within the 40 Meter Laboratory. Personnel safety shall not be assured by the CDS Network controlling the interferometer but by dedicated personnel safety systems. Personnel outside the Laboratory who must monitor operations shall access read-only screens, and not screens with live controls.

7.4. User Support

In addition to the CDS workstations and network connections required to operate the interferometer, there should be adequate General Computing workstations and printers for the staff expected to spend half or more of their time in the 40 Meter Laboratory. These facilities shall be comparable to what is available in LIGO offices on the Caltech campus. Software support should also be the same as in offices.

7.5. Data collection

The proposed retirement of the Concurrent computer requires the development of a new data collection scheme. This shall be provided by the CDS DAQ Network.

7.6. Slow Monitoring

TBD

LIGO-DRAFT

8 MIT COMPUTING SYSTEM FUNCTIONS AND REQUIREMENTS

8.1. General Requirements

The MIT network should have access to the same tools and information as the CIT network. This will require a some duplication of infrastructure at MIT and periodic file transfer to MIT to update a "mirror" site.

8.2. Networks

MIT will require two subnetworks:

- a General Computing Network similar in architecture to the Network at Caltech
- a CDS Data Acquisition Network for the Alignment R&D data acquisition, PNI support and subsequent development.

If the MIT interferometer laboratory moves off campus, a separate subnet (or pair of subnets) will be required.

8.3. Document Control Center

MIT shall have equivalent capability to generate document numbers, query the DCC database, and access electronic archives of LIGO documents. This shall be accomplished by installing equivalent clients at MIT and creating a "mirror" site of the DCC database with frequent, scheduled updates accomplished by a Unix daemon.

8.4. Scientific and Engineering Databases

This shall be accomplished by creation of "mirror" sites with periodic updating.

8.5. Scientific Modeling

MIT will operate a 2-cpu Sparc 20 as a Computation Server. MIT will require access to the Caltech Intel Paragon to support FFT modeling. Caltech staff will provide support for the MIT use of the Paragon.

8.6. Design analysis, design drafting

It shall be possible to access design drafting and analysis files from MIT, make design file modifications, though not extensive design development, and operate limited design analysis problems.

8.7. Data analysis

It shall be possible to analyze scientific data on the MIT General Computing Network.

8.8. Network and System Administration

MIT shall provide primary support for computing systems at a level of 0.5 FTE. Caltech General Computing shall provide backup support and assistance to assure a uniform and standardized LIGO computing environment at MIT. Some special purpose consulting will be required to supplement MIT computing support.

8.9. Remote Access

In addition to remote access through Athena (MIT Central Computing), direct PPP access shall be provided on the MIT LIGO General Computing Network.

8.10. Printing/Plotting

MIT printing/plotting needs shall be supported for all small formats up to C-size in monochrome and color. Larger formats shall be supported through Caltech LIGO or other sources local to MIT.

LIGO-DRAFT

9 OBSERVATORY SITE CONSTRUCTION PHASE COMPUTING SYSTEM FUNCTIONS AND REQUIREMENTS

9.1. General Computing

Observatory site General Computing during the construction phase shall be based upon LIGO standard Windows PC workstations and tools. A simple Windows 95 network shall be established. Printing and plotting shall be supported in A and B formats in monochrome and color.

9.2. Remote and Network Access

Observatory site computing workstations shall have ISDN or PPP access to the internet to facilitate file transfer and electronic communications. A fax modem capability shall be provided.

9.3. Computation and CDS Networks

No intensive computation or Control and Data Systems functions shall be supported during the construction phase.

LIGO-DRAFT

APPENDIX 1 LIGO NETWORK STANDARD**Table 3: Initial LIGO Network Standard**

<i>Network Element</i>	<i>Standard</i>
Network Operating System	Sun Solaris
Primary Servers	Sparc 1000
Network Cabling ?	100BaseT ?

LIGO-DRAFT

APPENDIX 2 LIGO HARDWARE STANDARDS

Table 4: Initial LIGO Hardware Standards

<i>Hardware Element</i>	<i>Standard</i>
Desktop Workstation	Pentium IBM PC compatible
Mobile Workstation	Toshiba Pentium Laptop
Scientific Workstation	SUN Sparcstation 5
Network Printer (non color)	Hewlett Packard
Network Printer (color)	HP 1200 CS or HP 1600 CM
Network Plotter	Hewlett Packard Design Jet 650C
Modem	Hayes Optima 28.8 kbps v.34

LIGO-DRAFT

APPENDIX 3 LIGO SOFTWARE STANDARDS

Table 5: Initial LIGO Software Standards

<i>Software Element</i>	<i>Standard</i>
Unix Operating System	Sun Solaris
Windows Operating System	Windows 95
Windows Xterminal/NFS	Xoftware 32
Word Processor	Adobe FrameMaker
Spreadsheet	Microsoft Excel 95
Database	Microsoft Access 95
Presentation Graphics	Adobe FrameMaker 5
Web Browser	Netscape (32 bit)
Electronic Document Formatter	Adobe Acrobat
Electronic Mail (Native Sun)	Sun Mailtool
Electronic Mail (pop3 protocol)	Eudora Pro
Appointment Calendar	Sun Calendar Manager
Mathematical Analysis	Mathematica
Design Analysis/Design Drafting	IDEAS
Visual Code Integration	AVS
Integration Drafting	AutoCAD
Technical Graphics	Island Draw
Compilers	Fortran, C

LIGO-DRAFT

APPENDIX 4 LIGO SPECIALIZED SOFTWARE

Table 6: Initial LIGO Specialized Software

<i>Software Element</i>	<i>Standard</i>	<i>Responsible Group</i>
	Oracle ?	
Cost/Schedule Relational Database	FoxPro	Project Controls
Cost Baseline	Cobra	Project Controls
Schedule Baseline	Open Plan	Project Controls
Electronics Circuit Design	Cadence	CDS Group
Controls	EPICS	CDS Group
Controls User Interface	Sammi	CDS Group
	VxWorks	CDS Group
	Code V	
	Matlab	

LIGO-DRAFT

APPENDIX 5 LIGO COMPUTING SYSTEMS MONI- TORED ELEMENTS DEFINITION

Table 7: Monitored Elements

<i>Element</i>	<i>Monitoring Method</i>	<i>Monitoring Frequency</i>

LIGO-DRAFT

unresolved issues:

ESNet between MIT - CIT

JPL tool compatibility

workstations as backup routes between subnets a la Ching

backup for main Cisco as per Ching

quantitative specification of server performance

quant. spec. of workstation performance

license admin ?prop. database

labels, travelers on workstations

slow mon. connection to 40 m daq net - VxWorks support

laptop loaner control

kerberos

ops phase transition statement

response time at login

network hardware standards

quantify reliability

MIT relation to CDS

apps - labview, pvwave, sm, mae, xvgr, TeX, tcsh

help desk

upgrade policies

monitored items

LIGO-DRAFT

1 INTRODUCTION

1.1. Purpose

This document defines the requirements for the LIGO Vacuum Control and Monitoring System (VCMS).

1.2. Scope

The end product, for which this document specifies the requirements, is an integrated Control and Data System (CDS) for the LIGO vacuum equipment at Hanford, WA and Livingston, LA. The primary function of the VCMS is to provide for remote operation and monitoring of LIGO vacuum equipment during LIGO operations. Included in this scope is:

- Hardware and software applications specific to Vacuum Equipment (VE) control and monitoring, including digital processing equipment, Input/Output (I/O) interfaces, interactive operator interfaces, data collection and conversion, signal conditioning, closed loop control, automatic sequences, interlocks and all necessary equipment housings.
- Hardware and software, as necessary, to interface the VCMS to the VE provided by the VE vendor and to the infrastructure of the LIGO CDS.

The VCMS is to be developed as an integrated subsystem of the LIGO CDS. As such, the system infrastructure and operational support components will be provided by the LIGO CDS and are not included in the scope of the VCMS. This includes such items as the data communication networks, operator consoles, compute servers, mass storage systems, and software development tools and general services.

Also not in the scope of the VCMS is control and monitoring functions associated with equipment, such as roughing and turbo pumps, used to initially pumpdown LIGO vacuum spaces. This function is to be provided by stand-alone control and monitoring systems associated with portable "pumpdown carts", which are to be provided by the Vacuum Equipment (VE) vendor, Process Systems International (PSI).

1.3. Definitions

1.4. Acronyms

- BSC Beam Splitter Chamber
- CDS Control and Data System
- CIM Computer Integrated Manufacturing
- FCR Facility Control Room
- GUI Graphical User Interface
- HAM Horizontal Access Module
- IFO Interferometer
- I/O Input/Output

- LIGO Laser Interferometer Gravitational Wave Observatory
- LN2 Liquid Nitrogen
- L/S Liters/Second
- MTBF Mean Time Before Failure
- MTTR Mean Time To Repair
- P&ID Piping and Instrumentation Drawing
- PSI Process Systems International
- RH Relative Humidity
- TBD To Be Determined
- VCMS Vacuum Control and Monitoring System
- VE Vacuum Equipment

1.5. Applicable Documents

1.5.1. LIGO Documents

T950120-C Global CDS Control and Monitoring Conceptual Design

1.5.2. Non-LIGO Documents

- Process Systems International (PSI) Drawing V049-0-001 through V049-0-017 Piping and Instrumentation Diagram (P&ID), dated November 3, 1995
- PSI transmittal V049-1-013, Approximate Total I/O Count for WA site, dated December 1, 1995
- PSI transmittal V049-1-036, Instrument List, dated February 12, 1996

2 GENERAL DESCRIPTION

2.1. Specification Tree

This document is part of an overall LIGO detector requirement specification tree. This particular document is highlighted in the following figure.

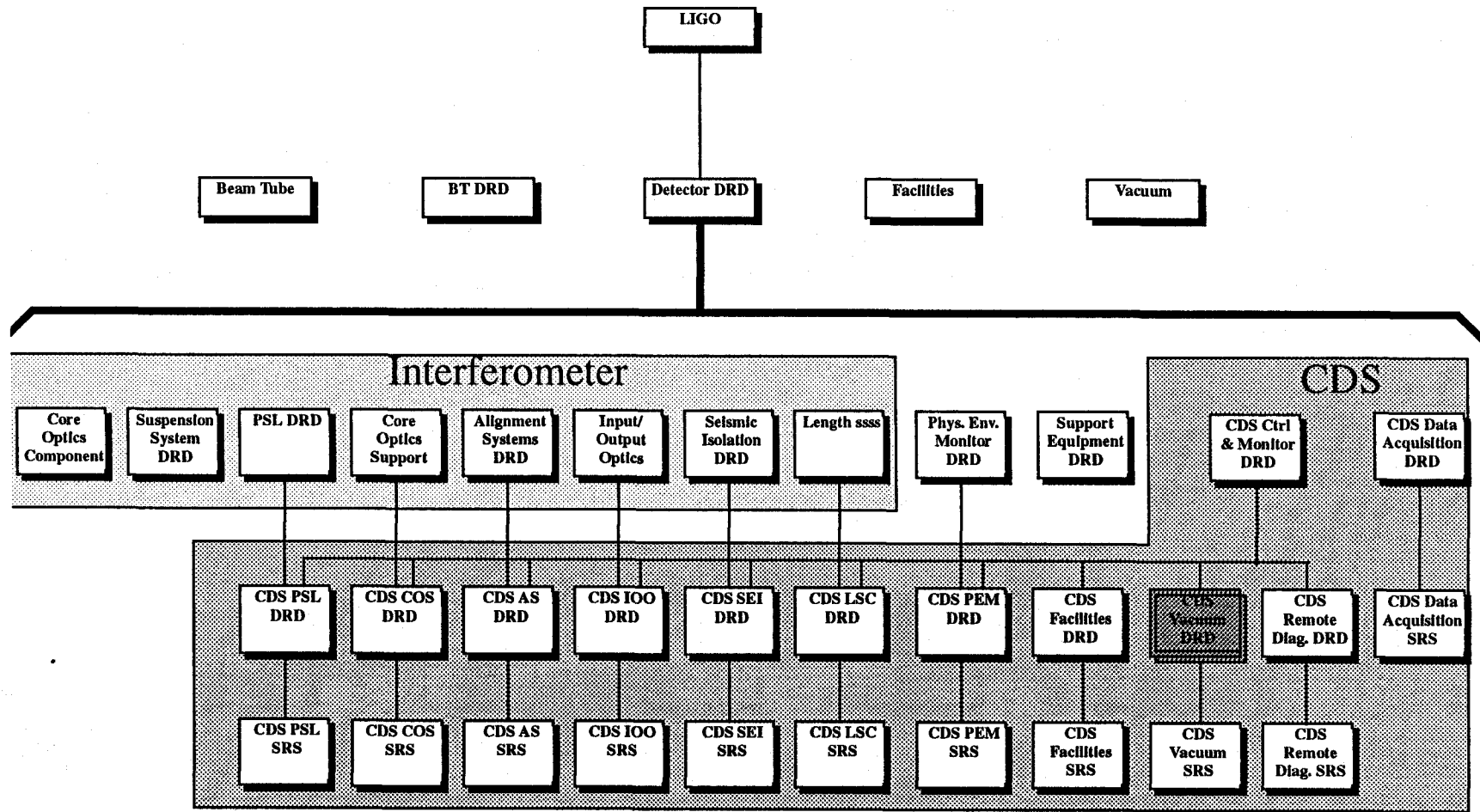

Figure 1: LIGO Specification Tree

2.2. Product Perspective

The VCMS is to be a subsystem of the larger LIGO CDS. Figure 2 depicts the relationship of the VMCS to the LIGO CDS and to the VE.

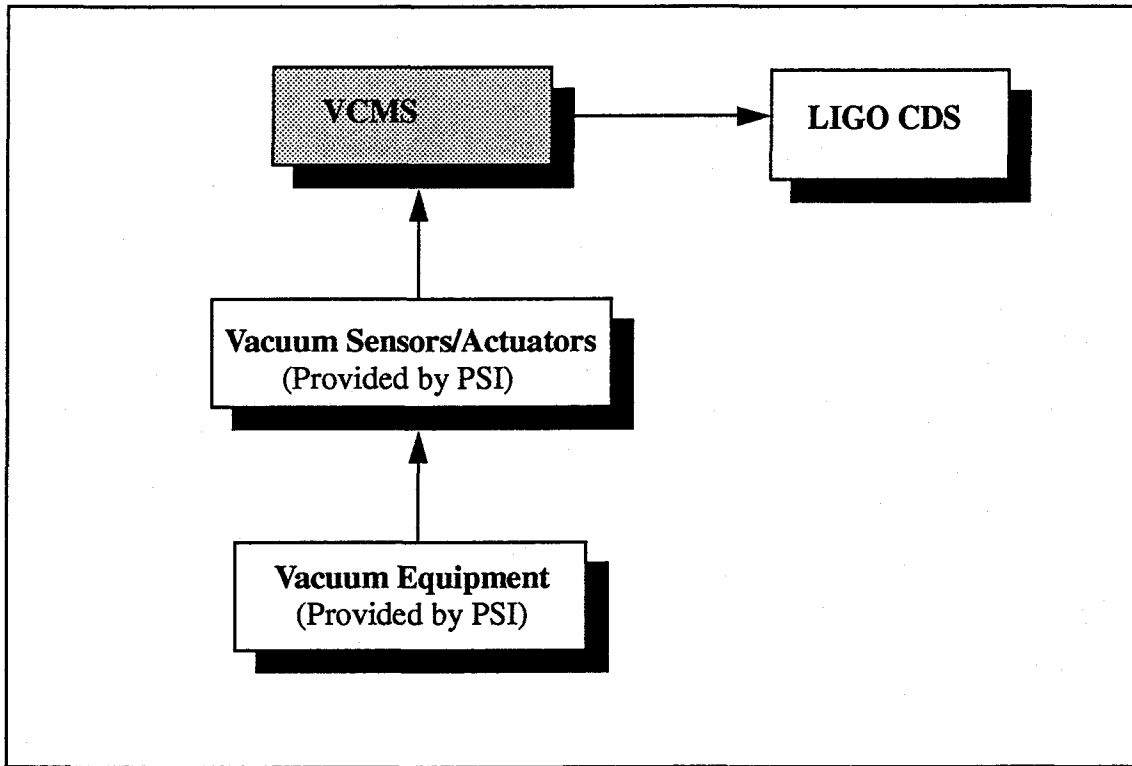

Figure 2: Product Perspective

2.3. Product Functions

The primary functions that the Vacuum CDS is to provide are:

- Monitoring of all sensors provided by the vacuum equipment manufacturer.
- Closed loop control of specified equipment.
- Appropriate interlocking systems, such that equipment is not operated in a hazardous manner.
- Local operation (adjacent to the equipment in the vacuum equipment areas) of all controlled and monitored vacuum equipment.
- Remote operation (from a central Facility Control Room (FCR)) of all controlled and monitored vacuum equipment.
- Operator interfaces, as necessary, to support both local and remote operation.
- Operational support services, such as data archiving and retrieval and alarm management.
- Integration with the remainder of the LIGO CDS systems.

2.4. General Constraints

The design and implementation of the Vacuum CDS shall be in compliance with the LIGO CDS control and monitoring requirements, LIGO T950054-C, and the global CDS design and design standards, as defined in LIGO T950120-C, to ensure proper integration with the remainder of the LIGO CDS.

2.5. Assumptions and Dependencies

2.5.1. LIGO Global CDS

The infrastructure, such as timing, networking, and operational support, will be provided by the LIGO CDS. As such, only requirements particular to the Vacuum CDS, such as particular display and alarm management layouts, are specified here and not the overall scheme for providing these functions.

2.5.2. Vacuum Equipment (VE) Design

The vacuum equipment and its sensors and actuators are being provided by PSI under contract to LIGO. The Vacuum CDS requirements are therefore highly dependent on the PSI designs and documentation. As details of the VE designs change, this document will be updated to reflect those changes.

2.5.3. System States

3 REQUIREMENTS

3.1. Introduction

A Computer Integrated Manufacturing (CIM) model has been developed and is used to as a guide to specify the VCMS requirements. This CIM model is shown in figure 3. The remainder of this section follows this model, from the system level down to the device level. At each level, requirements are listed which either:

- Are general requirements that pertain to that level and everything below that level.
- Pertain to the control and monitoring of multiple, lower level components. Example: System level would specify any requirements which would involve the control of multiple sub-systems; Subsystem level would specify the control requirements for multiple assemblies; etc.

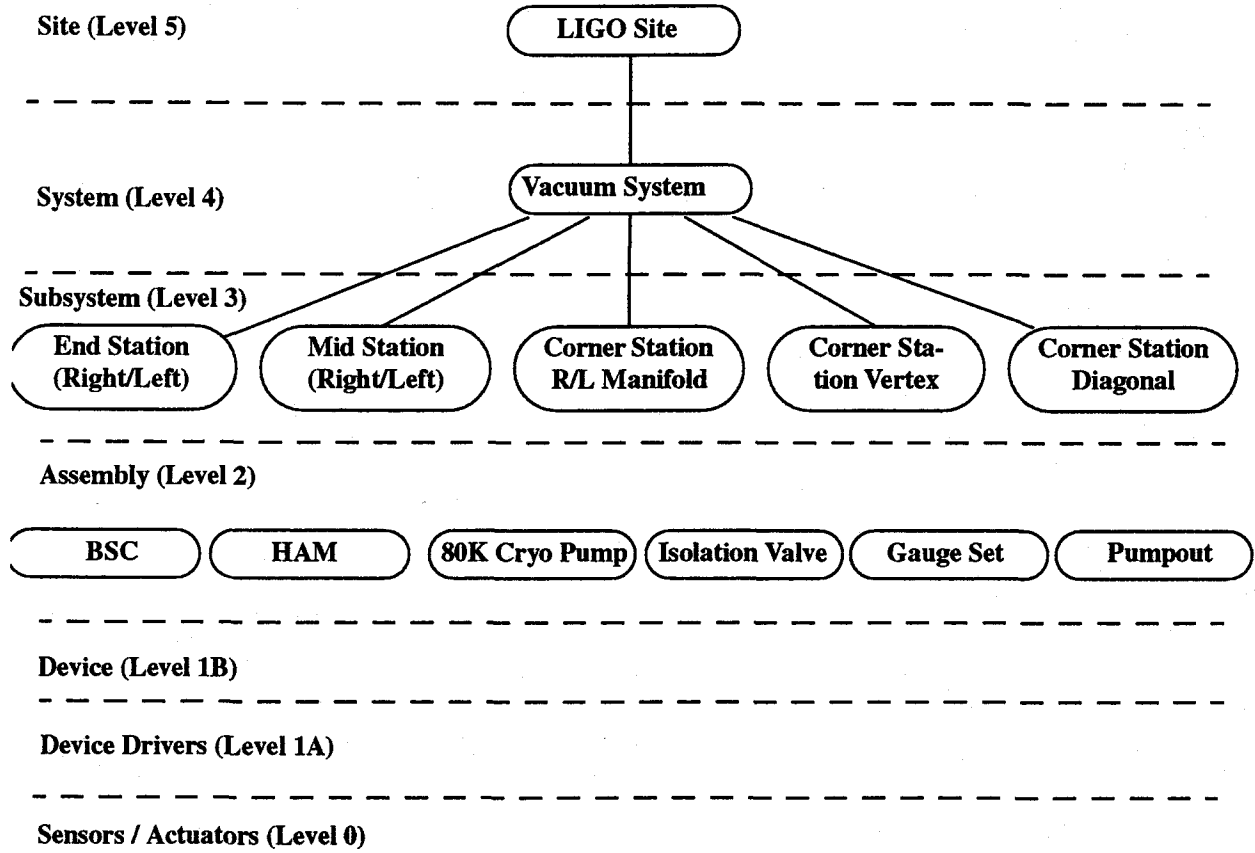

Figure 3: Vacuum System CIM Model

3.2. Characteristics

3.2.1. Performance Characteristics

3.2.1.1 System Level

3.2.1.1.1 General

The VCMS shall meet the applicable requirements as outlined in the LIGO CDS Control and Monitoring DRD, LIGO T950054-C, and be implemented using applicable standards as established in the LIGO CDS Control and Monitoring Conceptual Design, LIGO T950120-C. These documents provide the overall LIGO CDS requirements and design standards for the CDS infra-

structure, including timing and networking systems, to which the VCMS must interface, and operational support hardware and software, such as operator stations and software for operator displays, alarm management, and archival tools, which will provide the infrastructure for specific implementations required for the VCMS.

3.2.1.1.2 Operator Stations

3.2.1.1.2.1 Remote

Remote operator consoles are to be provided by the LIGO Global CDS in the Facility Control Rooms (FCR) at both LIGO sites. The VCMS operator interface displays shall be designed and implemented such that they can be run from any of the operator consoles in the FCR.

3.2.1.1.2.2 Local

Local, i.e. in the vicinity of the VCMS equipment racks in the Vacuum Equipment (VE) areas, operation of VE will be required during acceptance testing and maintenance periods. To support this, the VCMS shall provide TBD portable computers, which provide the same control and monitoring features as the FCR operator consoles for the subset of equipment in a particular area.

3.2.1.1.3 Operator System Level Displays

In general, the VCMS shall provide a hierarchy of operator interface displays, from a system overview panel, down through subsystem and assembly panels. Movement through this hierarchy shall be accommodated by the use of icon selections.

3.2.1.1.3.1 System Overview Panel

The following system level displays shall be provided as a minimum:

- **Navigator:** This window shall depict the various defined VE subsystems. On operator select of a subsystem, that subsystem overview window shall be displayed.
- **Vacuum Summary:** A summary window shall be provided which depicts the vacuum readings in all sections of the VE.
- **Pump Summary:** A summary window shall be provided which depicts the present status of all vacuum pumps.

3.2.1.1.3.2 System Trend Plots

Trend plots shall be provided to depict all vacuum readings in the system.

3.2.1.1.3.3 Use of color on displays

The use of certain colors shall be restricted and have specific meaning when applied to VCMS operator interface displays. These are:

- **Green:** Shall be used to indicate that a device is in its proper state to support LIGO laser operations.
- **Yellow:** Warning indication that a device is transiting to/from its proper state for high vacuum operations, or is not in its proper state for, but its present state is not critical to, high vacuum operations.
- **Red:** A device is in an alarm condition or is a critical item which is not in its proper state to

support high vacuum operations.

3.2.1.1.3.4 Symbols

Standard symbols, as shown on PSI drawings, for vacuum components shall be depicted for VE on operator displays. Along with the use of the previous standard colors, components shall also be shown with their present state i.e. opened/closed, on/off, etc.

3.2.1.1.4 VCMS Diagnostics

The VCMS shall provide self-diagnostics, in keeping with TBD LIGO CDS standards. These diagnostics shall be performed on all hardware and software associated with the VCMS.

3.2.1.1.5 VCMS Start-up

On power up or reset of any portion of the VCMS itself, the VCMS shall not disturb the present state of the VE. The VCMS shall detect the present state of the VE and update its internal state vectors to correspond to this state.

3.2.1.1.6 Interlocks

3.2.1.1.6.1 Overview

The primary interlocks associated with the LIGO VE is the opening of the large 44" and 48" vacuum section isolation valves. The VCMS shall provide a hierarchy of interlocks, as shown in Figure 4: Isolation Valve Interlock Chain, all of which must be met prior to permitting the opening of these valves.

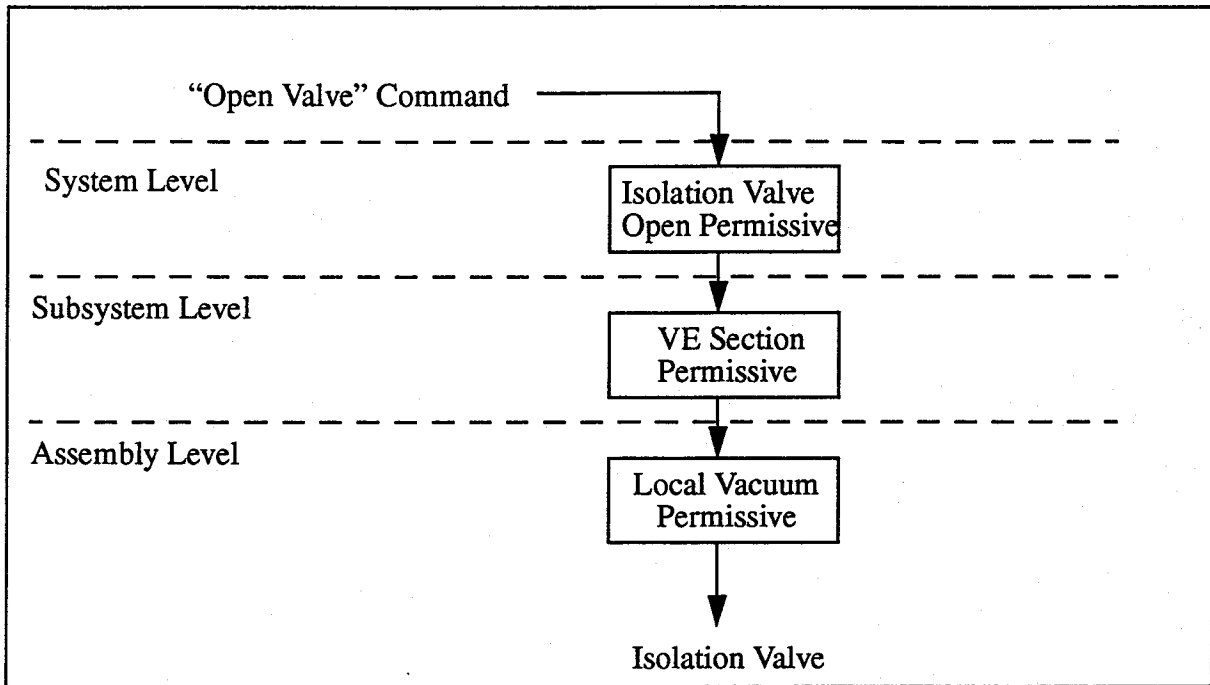

Figure 4: Isolation Valve Interlock Chain

3.2.1.1.6.2 *Isolation Valve Open Permissives*

The VCMS shall ensure that the two isolatable vacuum sections either side of an isolation valve have a "VE Section Permissive" (see section 3.2.1.2.2 Interlocks) prior to permitting opening of the associated isolation valve.

3.2.1.1.6.3 *Laser Operations*

The VCMS shall provide a "Laser Operations Permissive" signal to the LIGO CDS. This permissive shall be set True when and only when:

- The VCMS is operational as indicated by no failure in its self-diagnostic tests.
- VE system is at high vacuum state as indicated by all isolation valves being open, all high vacuum pumping operational, and all vacuum readings are in the normal, high vacuum range.

3.2.1.1.7 *Closed Loop Control*

None.

3.2.1.1.8 Automatic Sequences

3.2.1.1.8.1 Rate of Rise Calculations

The VCMS shall provide automatic rate of rise calculations for each isolatable vacuum section. Provisions shall be made to allow turning this function on/off and setting both the frequency and period of the calculations.

3.2.1.1.8.2 Fault Condition Monitoring and Corrective Action

Once the Laser Operation Permissive, defined above, is set to True, the VCMS shall automatically begin monitoring the rate of rise on all isolatable vacuum sections. If any of the rate of rise calculations are above a settable limit, a warning is to be issued through the VCMS alarm management system. If this condition continues beyond a set time limit after the warning, the VCMS shall automatically close all isolation valves. To support this feature, the VCMS shall provide:

- An adjustable rate of rise fault limit
- A time setting, indicating the time to wait between the warning condition and the automatic shutting of the isolation valve.
- An on/off mechanism, which would allow operators to turn on/off the automatic valve closing feature.

3.2.1.1.9 Alarm Management

3.2.1.1.9.1 General

The VCMS shall provide an alarm tree structure, which shall be viewable with the standard LIGO CDS alarm management software. This alarm tree shall be structured in the same manner as the VCMS CIM model. The VCMS shall monitor, record and enunciate all alarm conditions associated with the VE, as defined in following sections of this document.

One branch of the alarm tree shall be the internal VCMS self-diagnostics.

3.2.1.1.9.2 VCMS Status

The VCMS shall provide a TBD status word to the CDS, updated at a rate of TBD, indicating that the VCMS has/has not passed its self-diagnostic tests.

3.2.1.1.10 Data Archival

VCMS data archiving shall be developed and compatible with the standard LIGO CDS data archiving system. Specifically, the VCMS shall archive:

- All operator actions.
- The status of all VE equipment once every 10 minutes.
- The status of specific VE equipment on change of state beyond a deadband, as detailed in following sections of this document.

The VCMS shall also provide a method for operators to start and stop the data archival processes.

3.2.1.1.11 On-Line Documentation

All VCMS documentation shall be available on-line, i.e. displayed on request at any FCR console or local operator station.

3.2.1.2 Subsystems

The VCMS CIM has defined subsystems to agree with the PSI P&IDs to maintain the same terminology. These subsystems and the assemblies which they contain are:

1. Right and Left End Stations

- 80K Cryopump (1)
- 44" Isolation Valve (2)
- BSC (1)
- 2500 L/S Ion Pump (1)
- Gauge Set (2)
- 10" Pumpout Port (2)

2. Right and Left Mid Stations

Since only the Hanford site contains a 2Km IFO, the mid stations at the two sites differ in the assemblies which they contain. The Hanford site contains:

- 80K Cryopump (2)
- 44" Isolation Valve (4)
- BSC (1)
- 2500 L/S Ion Pump (1)
- Gauge Set (3)
- 10" Pumpout Port (3)

The Livingston site mid stations only contain the following assemblies:

- 44" Isolation Valve (1)
- Gauge Set (2)
- 10" Pumpout Port (2)

3. Corner Station - Right and Left Beam Manifolds

- 80K Cryopump (1)
- 44" Isolation Valve (2)
- BSC (1)
- 2500 L/S Ion Pump (1)
- Gauge Set (2)
- 10" Pumpout Port (2)

4. Corner Station - Vertex

- 48" Isolation Valve (2)
- BSC (3)
- HAM (6)
- 2500 L/S Ion Pump (4)
- 10" Pumpout Port (1)

5. Corner Station - Diagonal

The corner station diagonal at the Hanford site contains the following assemblies. Since Livingston only has one interferometer, this subsystem and its associated assemblies will not exist at that site.

- 48" Isolation Valve (2)
- BSC (1)
- HAM (6)
- 2500 L/S Ion Pump (2)
- 10" Pumpout Port (1)

3.2.1.2.1 General Subsystem Requirements

3.2.1.2.1.1 Operator Interfaces

An interactive GUI shall be provided for each defined subsystem. This GUI shall provide a background replicating the appropriate PSI P&ID.

A parameter page shall be provided which lists all devices and signal channels associated with a subsystem.

3.2.1.2.1.2 Device Operations

Isolation valves, ion pumps, and cryopump devices shall be operable via interactive icons on appropriate operator display pages. However, the operation of these units shall require two independent icons to be selected by the operator:

1. State to go to: Open/Close, On/Off
2. Verification, in the form of a Cancel/Confirm icon, that the Open/Close, On/Off request was not in error.

The purpose of this is to prevent the devices from changing states due to an inadvertent operator selection on a VCMS display.

3.2.1.2.1.3 Stand alone operation

To accommodate VE acceptance testing and certain maintenance periods, each VCMS subsystem shall be capable of stand alone operation i.e. without the LIGO CDS network backbone installed and/or operational.

3.2.1.2.2 Interlocks

3.2.1.2.2.1 Isolation Valves

Each VCMS subsystem shall provide a "VE Section Permissive", to be used by the VCMS system level interlock chain for the isolation valves, for each isolatable vacuum volume in its domain.

This VE Section Permissive shall be set True when, and only when,:

1. Isolation valve interlocks are satisfied. (See 3.2.1.3.4.1 Interlocks)
2. All ion pumps are on and operational within the isolatable section.
3. All pumpout port valves in that section are closed.

3.2.1.2.2.2 Subsystem Permissive

Each subsystem shall issue a permissive, i.e. ready for laser operations, for use by the system level interlocks when:

1. The conditions of 3.2.1.2.2.1 Isolation Valves are met.
2. All isolation valves associated with a subsystem are open.

3.2.1.2.3 *Closed loop controls*

None.

3.2.1.2.4 *Automatic sequences*

The various subsystems all contain ion pumps associated with various assemblies. For all ion pumps, the VCMS shall provide an automatic function which turns off an ion pump if its current reading is not in its normal operating range. This function will become active 30 seconds after an ion pump has been turned on and deactivated when a pump is turned off.

3.2.1.2.5 *Alarms*

The VCMS equipment associated with subsystems shall provide self-diagnostics to verify the status of the VCMS hardware and software. An alarm and/or warning, as appropriate, will be generated for any VCMS components which do not pass these self-diagnostic tests.

3.2.1.3 *Assemblies*

3.2.1.3.1 *80 K Cryo Pump*

The 80K Cryo Pump and its associated devices is shown in PSI P&ID V049-0-006. The signal channels to be monitored/controlled are shown in Table 1: 80K Cryo Pump Devices.

Table 1: 80K Cryo Pump Devices

<i>Description</i>	<i>Type</i>	<i>Signal Range</i>	<i>Engineering Unit Range</i>
Level Control Loop Output	AO		
Level Transmitter (LT)	AI		
Discharge Pressure Transmitter (DPT)	AI		
Discharge Temperature Thermocouple (DTT)	T/C		
Regen Loop Temperature Control Output	AO		
Regen Loop Temperature Thermocouple (RLTT)	T/C		
LN2 Dewar Level Transmitter (DLT)	AI		
Pirani Gauge Transmitter (PGT)	AI		

Table 1: 80K Cryo Pump Devices

<i>Description</i>	<i>Type</i>	<i>Signal Range</i>	<i>Engineering Unit Range</i>
Ion Gauge Transmitter (IGT)	AI		
Pumpout Port Valve (PPV) Closed Indications	DI		
Pumpout Port Valve (PPV) Open Indication	DI		

3.2.1.3.1.1 *Operator Displays*

The VCMS shall provide an interactive operator display which emulates the 80K cryopump P&ID V049-0-006. Such a display shall be provided for each cryopump.

3.2.1.3.1.2 *Interlocks*

The flow of liquid nitrogen (LN) from the LN Dewar to the cryopumps shall not be permitted when the pressure in the cryopump section is > TBD.

3.2.1.3.1.3 *Closed Loop Control*

The VCMS shall provide for closed loop control of the level within the LN2 Dewar and the regeneration temperature in accordance with specifications to be provided by PSI.

3.2.1.3.1.4 *Alarms*

The VCMS shall produce alarms and warnings for the 80K cryopump in accordance with the conditions shown in Table 2: 80K Cryopump Alarm and Warning Conditions.

Table 2: 80K Cryopump Alarm and Warning Conditions

<i>Device</i>	<i>Type</i>	<i>Alarm/Warning Condition</i>
Level Transmitter		
Discharge Pressure		
Discharge Temperature		
Regen Loop Temperature		
Dewar Level		
Pirani Gauge		
Ion Gauge		
Pumpout Port		

3.2.1.3.2 HAM Chamber

The devices which are associated with a HAM chamber and shall be controlled/monitored by the VCMS are shown in Table 3: HAM Chamber Devices.

Table 3: HAM Chamber Devices

<i>Description</i>	<i>Type</i>	<i>Signal Range</i>	<i>Engineering Unit Range</i>
75 L/S Ion Pump Remote Start/Stop	DO		
75 L/S Ion Pump Current Indication	AI		

3.2.1.3.2.1 Interlocks

None.

3.2.1.3.2.2 Closed Loop Control

None.

3.2.1.3.2.3 Automatic Sequences

The associated ion pump is to be turned off on a fault condition as described in 3.2.1.2.4 Automatic sequences.

3.2.1.3.2.4 Alarms

The VCMS shall enunciate alarm conditions for a HAM chamber as described in Table 4: Ham Chamber Alarm Conditions.

Table 4: Ham Chamber Alarm Conditions

<i>Device</i>	<i>Type</i>	<i>Alarm/Warning Condition</i>

3.2.1.3.3 Beam Splitter Chamber

The devices which are associated with a BSC and shall be controlled/monitored by the VCMS are shown in Table 5: BSC Chamber Devices.

Table 5: BSC Chamber Devices

<i>Description</i>	<i>Type</i>	<i>Signal Range</i>	<i>Engineering Unit Range</i>
Pressure Control Loop Output	AO		
Pirani Gauge Transmitter	AI		
Ion Gauge Transmitter	AI		
75 L/S Ion Pump Remote Start/Stop	DO		
75 L/S Ion Pump Current Indication	AI		

3.2.1.3.3.1 Interlocks

None.

3.2.1.3.3.2 Closed Loop Control

The VCMS shall provide closed loop control on the purge air lines to BSC 1,3,7, 8 at the Hanford site, and BSC 1,3 at the Livingston site. This control is to be in accordance with a TBD procedure to be specified by PSI.

3.2.1.3.3.3 Automatic Sequences

The associated ion pump is to be turned off on a fault condition as described in 3.2.1.2.4 Automatic sequences.

3.2.1.3.3.4 Alarms

The VCMS shall provide alarm enunciation for each BSC in accordance with Table 6: BSC Alarm Conditions.

Table 6: BSC Alarm Conditions

<i>Device</i>	<i>Type</i>	<i>Alarm/Warning Condition</i>

Table 6: BSC Alarm Conditions

<i>Device</i>	<i>Type</i>	<i>Alarm/Warning Condition</i>

3.2.1.3.4 Isolation Valves

The VCMS shall control and monitor the 44" and 48" isolation valves included in the VE. Table 7: Isolation Valve Devices lists the devices and signals associated with these valves.

Table 7: Isolation Valve Devices

<i>Description</i>	<i>Type</i>	<i>Signal Range</i>	<i>Engineering Unit Range</i>
25 L/S Ion Pump Remote Start/Stop	DO		
25 L/S Ion Pump Current Indication	AI		
Isolation Valve Open/Close Control	DO		
Isolation Valve Open Indication	DI		
Isolation Valve Closed Indication	DI		
Isolation Valve Common Alarm	DI		

3.2.1.3.4.1 Interlocks**3.2.1.3.4.1.1 Normal Operation**

The VCMS shall provide interlocks to prevent the inadvertent opening of these isolation valves. The VCMS shall not permit an isolation valve to open unless both of the following criteria are met:

- The nearest up and down stream Parani gauges both provide a reading of $< 1 \times 10^{-3}$ Torr
 - The nearest up and down stream Ion gauges both provide a reading of $< 1 \times 10^{-4}$ Torr
- When and only when these conditions are met, a "Local Vacuum Permissive" shall be set to True for use by the subsystem level interlock checks.

3.2.1.3.4.1.2 Maintenance/Test Mode

There will be certain times, such as during VE acceptance testing and at atmosphere maintenance periods, that it will be desired to operate the isolation valves without the VE system being under vacuum, and thereby not meeting the interlock requirements specified in 3.2.1.3.4.1.1 Normal

Operation above. Therefore, the VCMS shall provide a mechanical mechanism which allows bypassing these interlocks. This bypass mechanism:

- Shall not be readily accessible i.e. will require detailed knowledge of the system in order to introduce it into the system.
- Shall cause an alarm condition to be introduced into the VCMS alarm monitors, with visual and audible enunciation at operator stations.
- Shall cause a visual (red light) panel indication to be illuminated at the associated VCMS sub-system rack.

3.2.1.3.4.2 Closed Loop Control

None.

3.2.1.3.4.3 Automatic Sequences

The isolation valves shall be automatically closed on a fault condition as defined in section 3.2.1.1.8.2 Fault Condition Monitoring and Corrective Action.

3.2.1.3.4.4 Alarms

The VCMS shall provide alarm enunciation for isolation valves as defined in Table 8: Isolation Valve Alarm Conditions.

Table 8: Isolation Valve Alarm Conditions

<i>Device</i>	<i>Type</i>	<i>Alarm/Warning Condition</i>

3.2.1.3.5 Gauge Sets

Vacuum gauge pairs, consisting of a Parani and Ion gauge, will be placed along areas of beam tube and vacuum manifolds. The signals from these devices which shall be monitored by the VCMS are described in Table 9: Manifold Gauge Set Devices.

Table 9: Manifold Gauge Set Devices

<i>Description</i>	<i>Type</i>	<i>Signal Range</i>	<i>Engineering Unit Range</i>
Parani Gauge Transmitter	AI		
Ion Gauge Transmitter	AI		

3.2.1.3.5.1 Interlocks

None.

3.2.1.3.5.2 Closed Loop Control

None.

3.2.1.3.5.3 Automatic Sequences

None.

3.2.1.3.5.4 Alarms

The VCMS shall provide alarm enunciation for manifold gauge sets in accordance with Table 10: Gauge Set Alarm Conditions.

Table 10: Gauge Set Alarm Conditions

<i>Device</i>	<i>Type</i>	<i>Alarm/Warning Condition</i>

3.2.1.3.6 Pumpout Ports

Pumpout ports exist within each isolatable section of the VE for purposes of roughing down the vacuum system. A manual isolation valve is located at each port. The VCMS shall monitor the positions of these valves, as indicated in Table 11: Pumpout Port Devices.

3.2.1.3.6.1 Interlocks

None.

Table 11: Pumpout Port Devices

<i>Description</i>	<i>Type</i>	<i>Signal Range</i>	<i>Engineering Unit Range</i>
10" Port Valve Closed Indication	DI		
10" Port Valve Open Indications	DI		
6" Port Valve Closed Indication	DI		
6" Port Valve Open Indications	DI		

3.2.1.3.6.2 *Closed Loop Control*

None.

3.2.1.3.6.3 *Automatic Sequences*

None.

3.2.1.3.6.4 *Alarms*

The VCMS shall provide alarm enunciation for pumpout ports as defined in Table 12: Pumpout Port Alarm Conditions.

Table 12: Pumpout Port Alarm Conditions

<i>Device</i>	<i>Type</i>	<i>Alarm/Warning Condition</i>
Pumpout Port Valve	Alarm	Whenever the valve is in any state other than closed.

3.2.2. **Physical Characteristics**

3.2.2.1 **Electronic equipment housings**

To the extent possible and reasonable, all CDS electronic equipment shall be housed in standard 19" racks.

3.2.2.2 **Weight Limits**

CDS equipment to be housed within the OSB shall not exceed weight limits imposed by the building raised floor loading capacities.

3.2.3. Interface Definitions

3.2.3.1 Interfaces to other LIGO detector subsystems

3.2.3.1.1 *Mechanical Interfaces*

The VCMS shall provide a CDS standard hardware connection to the LIGO CDS communication networks.

3.2.3.1.2 *Electrical Interfaces*

The VCMS shall be electrically and software compatible with the LIGO CDS communication networks such that data can be transferred to/from the CDS infrastructure and the VCMS.

3.2.3.1.3 *Optical Interfaces*

None.

3.2.3.1.4 *Stay Clear Zones*

3.2.3.2 Interfaces external to LIGO detector subsystems

The VCMS will have interfaces to the facilities and the VE provided by PSI.

3.2.3.2.1 *Mechanical Interfaces*

3.2.3.2.1.1 *Facility*

All VCMS equipment shall be housed in rack enclosures, mounted to the LIGO facilities floor at those points designated in TBD.

3.2.3.2.1.2 *PSI*

The VCMS shall provide a standard 19" rack enclosure and terminal strips for the termination of PSI provided signal cables. This shall be the principle interface point between VE supplied by PSI and the VCMS, provided by the LIGO CDS group.

The VCMS shall provide mounting space (4U, 7") within the VCMS racks for the mounting of PSI provided 24VDC power supplies.

3.2.3.2.2 *Electrical Interfaces*

3.2.3.2.2.1 *Facility*

Facility power shall be provided at a circuit breaker panel within each of the building areas where VCMS is to be installed. Facilities shall provide 20A, 110VAC breakers at each panel, with a conduit and/or raceway from the panel to each VCMS rack enclosure. VCMS shall provide the necessary cable to connect the breaker panels to the VCMS racks and further distribute AC power.

3.2.3.2.2.2 PSI

The electrical connection between PSI provided equipment and the VCMS shall be at the terminal strips defined in section 3.2.3.2.1.2 above.

3.2.3.2.3 Stay Clear Zones**3.2.4. Reliability**

The Mean Time Before Failure (MTBF) for the CDS control and monitoring system shall be greater than TBD.

3.2.5. Maintainability

The Mean Time To Repair (MTTR) for any CDS component shall be less than TBD.

3.2.6. Environmental Conditions

The CDS control and monitoring system shall meet all performance requirements when exposed to all specified natural and induced environments.

3.2.6.1 Natural Environment**3.2.6.1.1 Temperature and Humidity**

All CDS equipment shall meet the following temperature and humidity requirements.

Table 13: Environmental Performance Characteristics

<i>Operating</i>	<i>Non-operating (storage)</i>	<i>Transport</i>
+0 C to +50 C, 0-90%RH	-40 C to +70 C, 0-90% RH	-40 C to +70 C, 0-90% RH

3.2.6.1.2 Atmospheric Pressure

The CDS equipment design must accommodate atmospheric pressure change from a maximum of 15.2 psia to a minimum of 14.2 psia.

3.2.6.2 Induced Environment**3.2.6.2.1 Vibrations**

CDS equipment shall not produce mechanical vibrations greater than those specified in TBD.

3.2.6.2.2 Acoustic Noise

CDS equipment shall be designed to produce the lowest levels of acoustic noise as possible and practical. In any event, CDS equipment shall not produce acoustic noise levels greater than TBD.

3.2.6.2.3 Electromagnetic Radiation

The CDS shall not degrade due to electromagnetic emissions as specified by IEEE C95.1-1991.

The CDS shall not produce electromagnetic emissions beyond those specified in TBD.

3.2.7. Transportability

All items shall be transportable by commercial carrier without degradation in performance. As necessary, provisions shall be made for measuring and controlling environmental conditions (temperature and accelerations) during transport and handling. Special shipping containers, shipping and handling mechanical restraints, and shock isolation shall be utilized to prevent damage. All containers shall be movable for forklift. All items over 100 lbs. which must be moved into place within LIGO buildings shall have appropriate lifting eyes and mechanical strength to be lifted by cranes.

3.3. Design and Construction

3.3.1. Materials and Processes

3.3.1.1 Finishes

- Ambient Environment: Surface-to-surface contact between dissimilar metals shall be controlled in accordance with the best available practices for corrosion prevention and control.
- External surfaces: External surfaces requiring protection shall be painted purple or otherwise protected in a manner to be approved.

3.3.1.2 Materials

All CDS equipment to be placed within LIGO vacuum systems shall be in accordance with the LIGO list of approved vacuum materials.

3.3.1.3 Processes

All CDS equipment to be placed within LIGO vacuum systems shall be processed in accordance with LIGO standards TBD.

3.3.2. Component Naming

All tagging and naming of CDS equipment shall be in accordance with LIGO naming standards TBD.

3.3.3. Workmanship

All details of workmanship shall be of the highest grade appropriate to the methods and level of fabrication and consistent with the requirements specified herein. There shall be no evidence of poor workmanship that would make the components unsuitable for the purpose intended. All electronic circuits, modules and wiring shall be consistent with good engineering practice and fabricated to best commercial standards.

3.3.4. Interchangeability

The CDS shall be designed to maximize interchangeability and replaceability of mating components. Using the Line Replaceable Unit (LRU) concept, the designs shall be such that mating assemblies may be exchanged without selection for fit or performance and without modification to the section, the unit being replaced or adjacent equipment. Mature, performance proven, standard, commercially available equipment shall not be modified unless it impacts safety.

3.3.5. Safety

This item shall meet all applicable NSF and other Federal safety regulations, plus those applicable State, Local and LIGO safety requirements. A hazard/risk analysis shall be conducted in accordance with guidelines set forth in the LIGO Project System Safety Management Plan LIGO-M950046-F, section 3.3.2.

3.3.6. Human Engineering

The CDS shall be designed and laid out in a manner consistent with applicable standard human engineering practices. Particular attention shall be paid to layouts of operator consoles/stations, work space and environmental conditions.

3.4. Documentation

3.4.1. Specifications

The following specifications shall be provided as part of the design process:

- Software Requirements Specification (SRS) for all software to be developed as part of the system.
- Interface Control Document (ICD)

3.4.2. Design Documents

The following design documents shall be provided:

- System overall design.
- System software design.

3.4.3. Engineering Drawings and Associated Lists

Engineering drawings, schematics, wire lists and cable routing lists shall be produced for the VCMS. To the greatest extent possible and practical, electronic copies shall be maintained and available on-line. All drawings shall be formatted according to LIGO standards.

3.4.4. Technical Manuals and Procedures

3.4.4.1 Procedures

Procedures shall be provided for, at minimum,

- Initial installation and setup of equipment
- Normal operation of equipment
- Normal and/or preventative maintenance
- Troubleshooting guide for any anticipated potential malfunctions

3.4.4.2 Manuals

The following manuals shall be provided:

- All manuals provided by commercial vendors for VCMS components.
- Manuals for all VCMS custom designed electronics and software.

3.4.5. Documentation Numbering

All documents shall be numbered and identified in accordance with the LIGO documentation control numbering system LIGO document TBD

3.4.6. Test Plans and Procedures

All test plans and procedures shall be developed in accordance with the LIGO Test Plan Guidelines, LIGO document TBD.

3.5. Logistics

The design shall include a list of all recommended spare parts and special test equipment required.

3.6. Precedence

In the event of conflicts between this requirement document and other LIGO documents, the order of precedence shall be in accordance with the LIGO Requirement Specification Tree.

3.7. Qualification

The VCMS design shall be qualified through a series of reviews as prescribed in the LIGO Detector Implementation Plan.