

LASER INTERFEROMETER GRAVITATIONAL WAVE OBSERVATORY
- LIGO -

CALIFORNIA INSTITUTE OF TECHNOLOGY
MASSACHUSETTS INSTITUTE OF TECHNOLOGY

Document Type LIGO-T960169-00 - CPD 10/31/96

**Vacuum Control and Monitoring
System (VCMS) Preliminary Design**

R. Bork

Distribution of this draft:

This is an internal working note
of the LIGO Project.

California Institute of Technology
LIGO Project - MS 51-33
Pasadena CA 91125
Phone (818) 395-2129
Fax (818) 304-9834
E-mail: info@ligo.caltech.edu

Massachusetts Institute of Technology
LIGO Project - MS 20B-145
Cambridge, MA 01239
Phone (617) 253-4824
Fax (617) 253-7014
E-mail: info@ligo.mit.edu

WWW: <http://www.ligo.caltech.edu/>

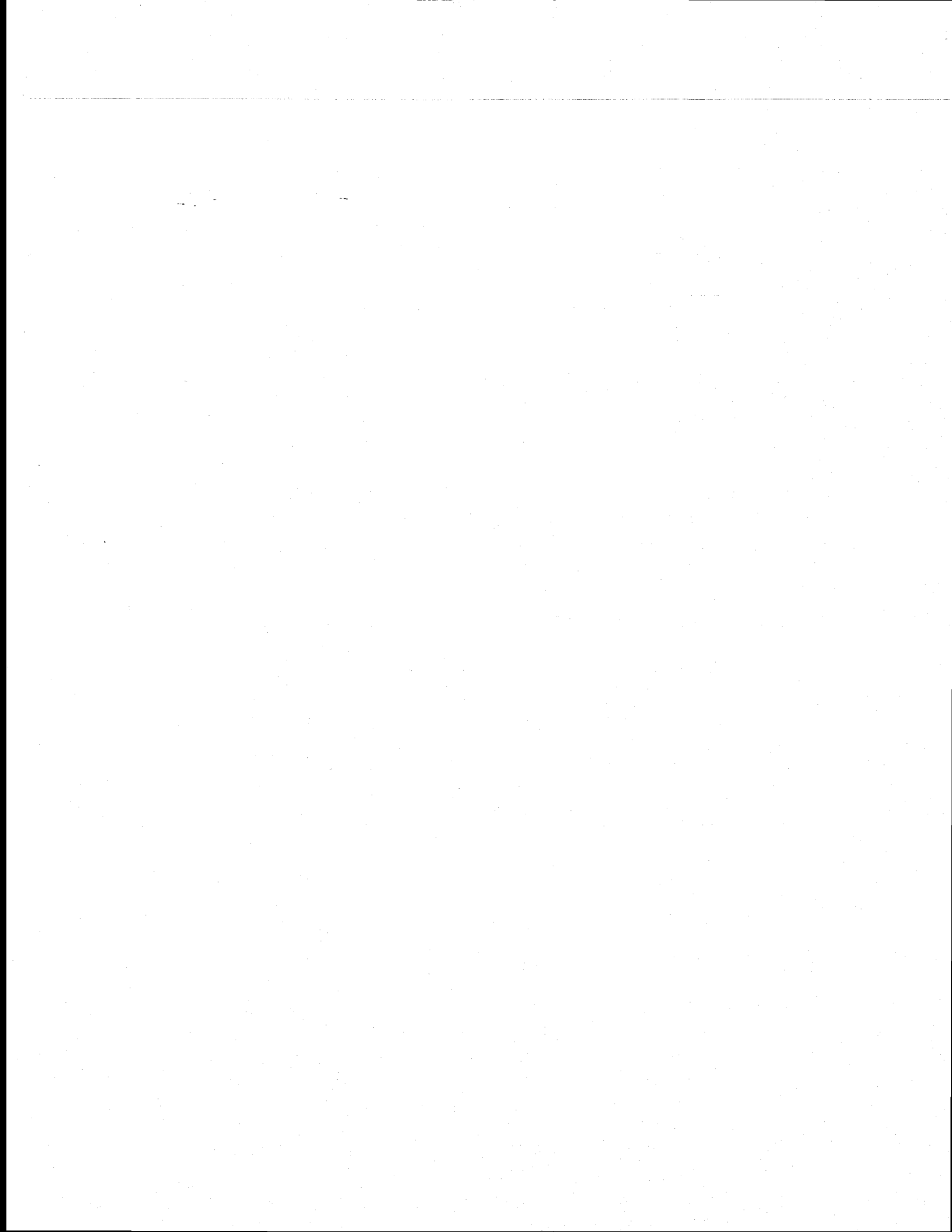

1 Introduction	4
1.1. Purpose	4
1.2. Scope	5
1.3. Document Overview	5
1.4. Definitions	5
1.5. Acronyms	5
1.6. Applicable Documents	6
1.6.1. LIGO Documents	6
1.6.2. Non-LIGO Documents	6
2 General Description	7
3 Design	8
3.1. System Level	8
3.1.1. Operator Stations	8
3.1.2. Operator Interfaces	8
3.1.3. Alarm Management	8
3.1.4. Data Archival	8
3.1.5. VCMS Self Diagnostics	9
3.1.6. VCMS Startup	10
3.1.7. Power Failure	10
3.1.8. System Status Reporting	10
3.1.9. On-Line Documentation	10
3.2. Subsystems	10
3.2.1. VCMS Rack Configuration	10
3.2.1.1 Rack Enclosures	11
3.2.1.2 Service Panel	11
3.2.1.3 Control Signal Power Supplies	11
3.2.1.4 Signal Interfaces	11
3.2.1.5 VME Crate	11
3.2.1.5.1 Frame	11
3.2.1.5.2 Processor	12
3.2.1.5.3 Timing	12
3.2.1.5.4 Analog Signal Conditioning and ADC	12
3.2.1.5.5 Analog Output	12
3.2.1.5.6 Binary Input/Output	12
3.2.1.5.7 Gate Valve Interlock Module	12
3.2.1.5.8 Watchdog Timer Module	12
3.2.1.6 UPS	13
3.2.2. Software	14
3.2.2.1 Overview	14
3.2.2.2 Control and Monitoring Modules	14
3.2.2.3 Diagnostics	14

3.3. Assemblies	14
3.3.1. Beam Tubes	14
3.3.1.1 Gauge Pairs	14
3.3.1.2 Turbo Pump Carts	15
3.3.2. Beam Manifolds	15
3.3.3. 80K Cryopumps	15
3.3.3.1 Operator Displays	16
3.3.3.2 Level Control	16
3.3.3.2.1 Initial Fill	17
3.3.3.2.2 Enabling the Flow Valve	17
3.3.3.2.3 Manual Control	17
3.3.3.2.4 Automatic Control	18
3.3.3.2.5 Fault Protection	18
3.3.3.2.5.1 Power Loss or VCMS Failure	18
3.3.3.2.5.2 Rise in Pump Vacuum or Overpressure	18
3.3.3.3 Regeneration Temperature Control	18
3.3.3.3.1 Electrical Connections	18
3.3.3.3.2 Software Monitoring and Control	19
3.3.3.3.3 Fault Protection	19
3.3.3.3.3.1 Over Temperature	19
3.3.3.3.3.2 VCMS Failure	19
3.3.3.4 Discharge Line Monitoring	19
3.3.3.5 Dewar Level Monitoring	20
3.3.3.6 Gauge Pair Monitoring	20
3.3.3.7 10" Pumpout Port Monitoring	20
3.3.4. HAM Chambers	20
3.3.5. Beam Splitter Chambers	20
3.3.6. Vacuum Section Isolation Valves	20
3.3.6.1 Design Changes	20
3.3.6.2 Valve Opening	21
3.3.7. 2500 l/s Ion Pumps	23
4 Fabrication Plan	23
4.1. Hardware	23
4.1.1. VCMS Racks	23
4.1.2. VME Equipment	23
4.2. Software	24
5 Test Plan	24
6 Installation Plan	24
<i>Appendix A: Electrical Drawings</i>	<i>25</i>
<i>Appendix B: Example Operator Display Panels</i>	<i>26</i>
<i>Appendix C: Software Diagrams.....</i>	<i>27</i>

Appendix D: Vacuum Section Isolation Valve Interlock Module Design..... 28

1 INTRODUCTION

1.1. Purpose

This document describes the preliminary design for that portion of the LIGO vacuum controls to be provided by the LIGO CDS group, hereafter referred to as the LIGO Vacuum Control and Monitoring System (VCMS). It is specifically designed to meet the requirements as set forth in *LIGO-T960024-C, VCMS Design Requirements*.

As can be seen in Figure 1: LIGO Vacuum Related Control Systems, various systems are involved in the control and monitoring of the LIGO vacuum systems. In general, these systems control and monitor different phases of the vacuum system operation.

- **Beam Tube Bakeout:** A separate system (provider TBD) will be used for initial pumpdown and bakeout of the LIGO beam tubes. This system is totally separate of the VCMS and the VCMS has no responsibilities for or connections to this system.
- **Pump Cart System:** The Vacuum Equipment (VE) vendor (Process Systems International (PSI)) will provide portable turbo and roughing pump systems for the purposes of initial pumpdown of VE to high vacuum. The VCMS shall provide for limited monitoring of these systems.
- **VE Bakeout:** PSI will provide control and monitoring as necessary to initially bakeout the VE components. This is a separate system from the VCMS.
- **Purge air control:** PSI will provide the controls necessary for applying purge air to the system. This is to be a portable system. (*Note: This is a change from the original requirements, in which this was a requirement on CDS to control. The PSI design for this system has changed, with CDS no longer providing control or monitoring of this function.*)
- **VCMS:** This is the system defined by this document. In general, the VCMS is responsible for control and monitoring of systems during "normal" high vacuum conditions.

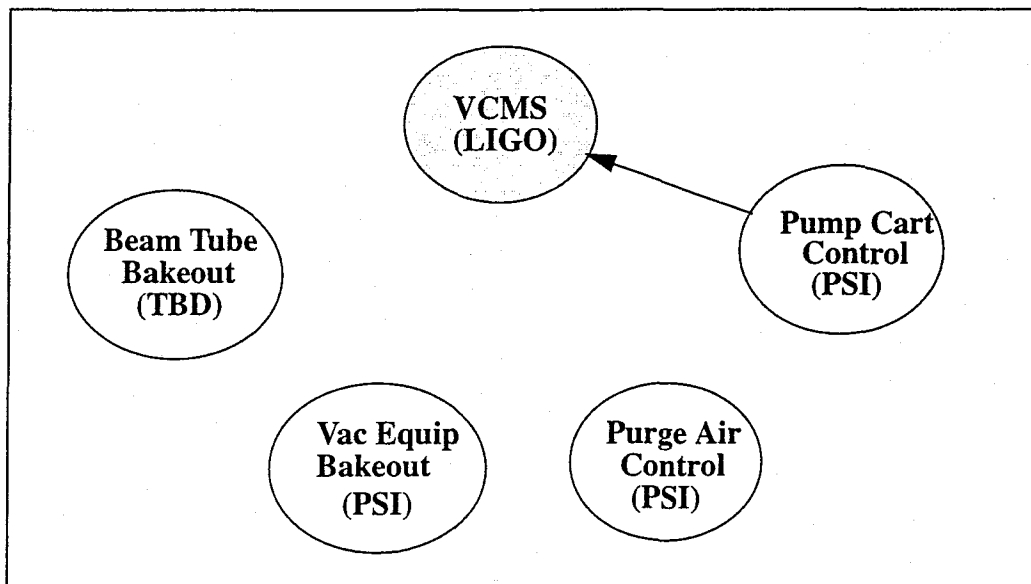

Figure 1: LIGO Vacuum Related Control Systems

1.2. Scope

The VCMS is designed as an integrated subsystem of LIGO Control and Data Systems (CDS). Its scope is to provide for the control and monitoring of all VE equipment used during "Normal" LIGO operations. "Normal" operation is defined here as all LIGO vacuum systems are pumped down to the high vacuum conditions required for laser operation. As shown in the previous figure, separate systems, provided by others, supply control and monitoring for other VE activities, such as bakeout, purge air venting and pumpdown from atmosphere to high vacuum conditions.

1.3. Document Overview

The design described by this document is primarily based on the system to be developed for the LIGO Hanford site. The Livingston VCMS will be similar, the primary difference being the reduced number of I/O points due to only one interferometer at that site.

To describe the design, this document is organized by sections as follows:

- Introduction, of which this subparagraph is a part, which gives the scope and definitions of the VCMS.
- General Description, which gives a brief overview of the design.
- Design Section, which describes the design in detail from system level down to assembly level.
- Fabrication and Installation Plan
- Test Plan
- Electrical/Mechanical Drawings (Appendix A). While a complete set exists for the Hanford site (as listed in the table in the beginning of Appendix A), only the drawings for the Hanford right mid station are included here. These are intended as a representative sample of all assemblies for the VCMS.
- Prototype Operator Display Panels (Appendix B).
- Software Diagrams (Appendix C). Again, a representative set from the Hanford right mid station.
- Isolation Valve Interlock Module design (Appendix D).
- Failure Modes Analysis (Appendix E).

1.4. Definitions

1.5. Acronyms

- A - Amps
- ADC - Analog to Digital Convertor
- BSC - Beam Splitter Chamber
- BT - Beam Tube
- CDS - Control and Data System
- D/A - Digital to Analog
- EPICS - Experimental Physics and Industrial Control System
- FCR - Facility Control Room
- GPS - Global Positioning System
- HAM - Horizontal Access Module
- Hz - Hertz
- I/O - Input/Output

- LN2 - Liquid Nitrogen
- l/s - liters/second
- mA - milliampere
- mm - millimeters
- P&ID - Piping and Instrumentation Diagram
- PLC - Programmable Logic Controller
- PSI - Process Systems International
- SNL - State Notation Language
- TBD - To Be Determined
- UPS - Uninterruptable Power Supply
- VCMS - Vacuum Control and Monitoring System
- VDC - Volts Direct Current
- VE - Vacuum Equipment
- VME - Versa Modular Eurocard

1.6. Applicable Documents

1.6.1. LIGO Documents

LIGO T960024-C VCMS Design Requirements Document

LIGO T960142-C LIGO CDS Control and Monitoring Preliminary Design

LIGO E950091-E Interface Control Document: LIGO System & Detector - Vacuum Equipment

LIGO CDS drawings as listed in the table of Appendix A.

1.6.2. Non-LIGO Documents

- Process Systems International (PSI) Piping and Instrumentation Drawings (P&ID), dated March 20, 1996, as listed in the following table:

Table 1: PSI P&ID Listing

<i>PSI Number</i>	<i>LIGO Number</i>	<i>Rev</i>	<i>Description</i>	<i>Sheets</i>
V049-0-001	D960107-00-V	0	Vac Equip Legend	3
V049-0-002	D960108-00-V	0	BSC Mid Stations	1
V049-0-003	D960109-00-V	0	BSC Corner Vertex Arms	1
V049-0-004	D960110-00-V	0	Horizontal Access Module	1
V049-0-005	D960111-00-V	0	112cm and 122cm Gate Valves	1
V049-0-006	D960112-00-V	0	80K Cryopump	1
V049-0-010	D960113-00-V	0	Washington LT End Station	1

Table 1: PSI P&ID Listing

<i>PSI Number</i>	<i>LIGO Number</i>	<i>Rev</i>	<i>Description</i>	<i>Sheets</i>
V049-0-011	D960131-00-V	0	Washington LT Mid Station	1
V049-0-012	D960114-00-V	0	Washington LT Beam Manifold	1
V049-0-013	D960115-00-V	0	Washington Vertex Section	1
V049-0-014	D960116-00-V	0	Washington Diagonal Section	1
V049-0-015	D960117-00-V	0	Washington RT Beam Manifold	1
V049-0-016	D960118-00-V	0	Washington RT Mid Station	1
V049-0-017	D960119-00-V	0	Washington RT End Station	1
V049-0-018	D960120-00-V	0	Washington Crnr St Mechanical Rm	1
V049-0-020	D960121-00-V	0	LA Left End Station	1
V049-0-021	D960122-00-V	0	LA Left & Right Mid Joints	1
V049-0-022	D960123-00-V	0	LA Left Beam Manifold	1
V049-0-023	D960124-00-V	0	LA Vertex Section	1
V049-0-024	D960125-00-V	0	LA Right Beam Manifold	1
V049-0-025	D960126-00-V	0	LA Right End Station	1
V049-0-026	D960127-00-V	0	LA Corner St Mechanical Rm	1

- PSI transmittal V049-1-013, Approximate Total I/O Count for WA site, dated December 1, 1995
- PSI transmittal V049-1-036, Rev. 1, Instrument List, dated March 11, 1996

2 GENERAL DESCRIPTION

The basic design of the VCMS follows the design standards established in the overall LIGO CDS design. These are covered in *LIGO CDS Control and Monitoring Preliminary Design T960142-C*.

The design of the VCMS calls for the use of standard CDS VME-based systems to provide process controls and monitoring. A total of seven VME units with processors will be employed at each site, as shown in D961403-00-C, included in Appendix A. These units will all be interconnected via ethernet to the LIGO CDS networking infrastructure, allowing central control and monitoring from the site Facility Control Room (FCR).

LIGO CDS standard EPICS software tools will be used for software development, as well as to provide the runtime control and monitoring functions.

3 DESIGN

3.1. System Level

3.1.1. Operator Stations

The VCMS will share the operator consoles of the FCR. The VCMS will be fully integrated and compatible with all CDS systems, therefore VCMS operator displays can be viewed on any workstations connected to the CDS networks.

In addition, during the commissioning phase, individual workstations will be supplied for each VCMS subsystem, as described in section 3.2.

3.1.2. Operator Interfaces

Operator interfaces for the VCMS will be developed and run under the LIGO CDS standard Sammi software. Displays will be developed in a hierarchical structure, with icon and menu driven selections to rapidly move between displays. The minimum set of displays are to be:

- System overview(s)
- Overview for each vacuum section
- Cryopump overview
- Individual cryopump displays
- VCDS diagnostics page
- Various trending plots

Example prototype display pages can be found in Appendix B.

3.1.3. Alarm Management

Alarm enunciation and logging is to be done with the EPICS alarm manager. The vacuum system will be a branch of the site alarm tree, with vacuum subsystems as additional lower level branches. The alarm manager will log all alarms and warnings when setpoints are exceeded and when the values drop back within the normal ranges.

During the commissioning phase, alarm management will run on the local Sun workstations described in section 3.2. Once LIGO networks are operational, this function will operate on a central CDS server.

3.1.4. Data Archival

Data archival will be accomplished with the EPICS data archival tools. In general, logging of various signal types will occur as follows:

- All digital (binary) signals will be logged on change.
- All analog signals will be logged when they change by more than their defined archive deadbands.

- All operator actions will be logged whenever they are changed. These will be logged to a separate file.

3.1.5. VCMS Self Diagnostics

The VCMS will monitor its own hardware and software status. This status will be reported on a separate operator display page, as well as enunciating faults via the VCMS alarm manager.

Figure 2: VCMS Self Diagnostics Tree shows the structure of the VCMS self diagnostics. For each VCMS VME processor, diagnostics will be run every 10 seconds. The hardware will be checked by one code module, the specific checking to be performed dependent on the I/O module type. This code will present a byte encrypted word to the VCMS VME master diagnostic program which indicates the status of all modules in the VME crate.

Each software module developed for the VCMS will also run diagnostics on demand from the VME master diagnostic program every 10 seconds. Status returned will be the present state of the program. The master diagnostic program will also initiate an alarm on non-response of software to diagnostic requests.

One central CDS VME processors will be assigned as a master for overall system diagnostics. It will collect the various status information from each individual processor and ensure that they are all operating properly. One other processor will be assigned as a backup to this function to monitor the health of the master unit itself.

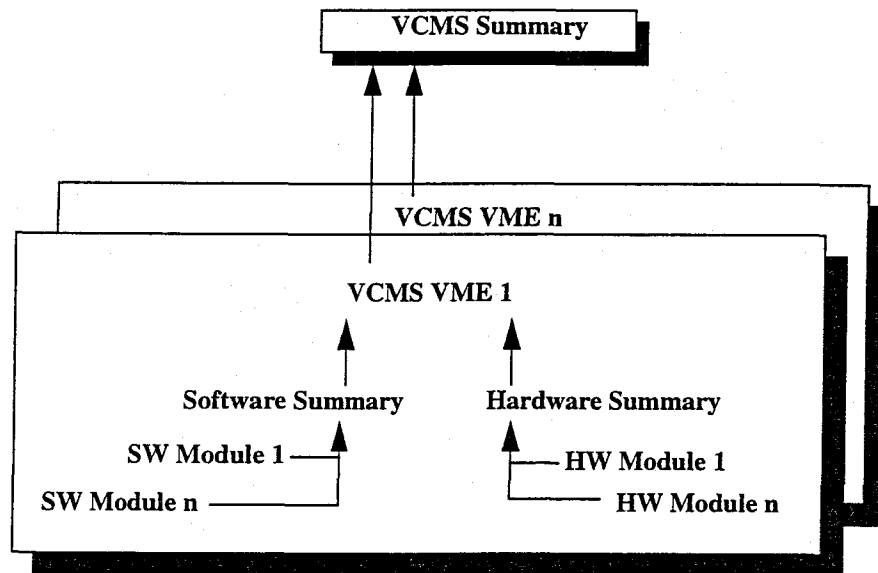

Figure 2: VCMS Self Diagnostics Tree

3.1.6. VCMS Startup

The hardware and software of the VCMS is designed such that it will not disturb the present state of the VE on power up or other normal startup. All of the individual VME subsystems of the VCMS may be powered up/down independently of each other.

3.1.7. Power Failure

All VCMS units are supplied with individual Uninterruptable Power Supplies (UPS). If AC power to VCMS is lost, alarms will be generated to notified operators. If power outage continues beyond 75% capacity of the UPS, the VCMS units affected will shut themselves down. The state of the VE will not be affected (if the VE still has power) by the shutdown of the VCMS, except to bring certain controls to a safe state, as described in sections 3.2 and 3.3.

3.1.8. System Status Reporting

The VCMS is to provide an overall status message(s) to other CDS systems. The nature of this status reporting has not yet been defined. Once defined, this will be designed and implemented as a standard EPICS record, which would then be available to any other CDS system which desires that information.

3.1.9. On-Line Documentation

As a minimum, all VCMS documentation will be available on-line to operations staff through the LIGO standard publishing package (Framemaker) in a view only mode. Also, all VCMS documents are in the LIGO Document Control Center.

3.2. Subsystems

The VCMS is divided into seven subsystems at Hanford, five at Livingston (*No control/monitoring is required or provided at Livingston midstations*). Each subsystem consists of a CDS standard rack enclosure, VME crate, Sun workstation and necessary signal interconnection wiring. The electrical and mechanical drawings for a representative subsystem (Hanford Right Midstation) is included in Appendix A and referenced by the following sections.

3.2.1. VCMS Rack Configuration

A typical VCMS rack is shown in Appendix A in LIGO D961337-00-C. Each rack comprises a complete stand-alone (networking connections not required for operation) control and monitoring system in of itself. It provides:

- Termination and interconnection points for signal cable connections.
- Service panel w/AC breakers for providing internal power
- 24VDC power supplies (2 ea, one provided by LIGO CDS, the other provided by PSI) for sensor power and control signals (NOTE: All control/monitoring signals are low voltage/power ie switched +24VDC/Ground, 4-20mA or thermocouple signals).
- A VME crate w/processor and I/O modules. This processor provides for all control and monitoring functions for VE connected to this rack.
- A Sun workstation w/17" monitor (not shown in drawing). These units will be placed on shelves

in all VCMS racks for initial testing, commissioning and acceptance tests. These take the place of the operator stations in the FCR during this phase, along with providing for data archival and alarm management. After that period, they may move elsewhere for other LIGO commissioning activities.

- A UPS for maintaining rack power for 15 minutes on loss of building AC.

3.2.1.1 Rack Enclosures

The rack enclosures are LIGO CDS standard racks. These racks are wider than typical 19" rack enclosures to accommodate field cable access from the side base of the rack and connection into cross field wiring terminations. These racks are entirely enclosed, with front (clear glass) and rear doors and side panels. The top panel is a pagoda arrangement to allow air flow.

3.2.1.2 Service Panel

At the top of each rack is what is called a service panel. This is a 1U (1.75") panel which contains two 15A breakers, which provide power within the rack, and a 10baseT ethernet connection for connecting portable computers.

3.2.1.3 Control Signal Power Supplies

Two +24VDC power supplies rated at 10A are installed in each rack. One power supply is for exclusive use of LIGO CDS provided components. The second supply is furnished by PSI for powering of PSI sensors and control signals to PSI provided equipment.

3.2.1.4 Signal Interfaces

As shown in the side view of the drawing, each VCMS rack is provided with three DIN rails for mounting wire terminal blocks and three 3" cable guides to route field and interconnection cabling. The two left most rails in the side drawing contains Phoenix mass termination units. These mass terminals are used for the connection of interface signals to the I/O modules in the VME crate via 50 or 64 pin ribbon cables. The right most rail contains Phoenix UK4 terminals of various types (dependent on signal type) for connection of all PSI field cabling.

VE signal wiring to be provided by PSI will enter through the side base of each rack. It is then to be routed through the plastic cable guide (shown on the right hand side of the drawing) and connected to the up to 200 terminal blocks provided. All other wiring within the enclosures will be done by LIGO staff. This includes connection of 24VDC to appropriate terminals from the 24VDC power supplies and all signal interconnection to the Phoenix mass termination.

The only field cabling to be provided by the LIGO CDS group for the VCMS is to the portable pump carts. This cable will again enter through the base and be routed to the Phoenix mass termination blocks located on the far left DIN rail in the side drawing.

3.2.1.5 VME Crate

3.2.1.5.1 Frame

The VME crate itself is a 21 slot powered 6U VME unit. Each is rated at 750W and contains fan units to provide air flow to all modules.

3.2.1.5.2 Processor

The primary processor for the VCMS will be a Motorola MVME-162, which is a 68040 processor based unit. Connection to the CDS networks is via an ethernet connection to an MVME-712 transition module installed in a slot at the rear of the VME crate.

3.2.1.5.3 - Timing

The TSAT Global Positioning System (GPS) module in slot 1 is the LIGO standard for time synchronization of all LIGO systems. Since the VCMS is to be the first installed LIGO CDS, the VCMS VME crates will contain the master receiver units in each building. In the corner station, one VME crate will contain a receiver and the other two slave units connected to the receiver unit via coax cable. Time synchronization will be via IRIG-B. All VCMS data will be timestamped using this system.

3.2.1.5.4 Analog Signal Conditioning and ADC

Analog signal conditioning will be done using a VMIC-3413 module. This unit will accept -10 to 10VDC, 4-20mA and thermocouple inputs. It has 32 channels, with each channel individually configurable for the various input types. The output of this unit is directly signal and cable compatible with the VMIC-3113 Scanning ADC module. This unit provides 64 ADC channels with 12 bit resolution.

3.2.1.5.5 Analog Output

Various control loops to be provided by the VCMS require 4-20mA outputs to actuators. To provide this, the VMIC-4120 will be used. Each module contains eight, 12 bit resolution, DAC channels.

3.2.1.5.6 Binary Input/Output

All VCMS binary I/O will be using 24VDC. Xycom 212 binary input modules will be used for signal sensing. Relay contacts will be used for all binary outputs. These will be provided using VMIC 2232 relay output modules.

3.2.1.5.7 Gate Valve Interlock Module

As will be described in section 3.3, interlocks are to be provided to prevent opening the large vacuum section isolation valves unless certain conditions are met. This interlock will be provided at several levels, one of which is verification by hardware incorporated in the VCMS. This hardware interlock check will be accomplished using a LIGO designed VME module. Preliminary designs for this module are shown in Appendix D. Further discussion of this interlock is in section 3.3.6.2 Valve Opening

3.2.1.5.8 Watchdog Timer Module

The watchdog timer is a general purpose CDS module which provides protection capabilities in the event of unexpected loss of power or processor hardware/software failure such that the processor can no longer communicate with VME I/O. This module basically consists of a timer circuit and some SPDT relays. The relay contacts are typically in series with signals which are to be disconnected if the watchdog timer times out. Basic operation of the unit is as follows:

- On power up of the processor, a command is sent via the VME bus to the watchdog timer to arm the timer circuitry. This will also cause the relays to be energized, thereby providing a through connection of the desired signals.
- When operating normally, software in the processor will constantly reset the timer at least once

every 30 seconds.

- Should the timer fail to receive a reset within 30 seconds, it will time out. This will cause the relays to deenergize and also cause a reset to be applied to the VME bus, which will cause the processor to reboot.

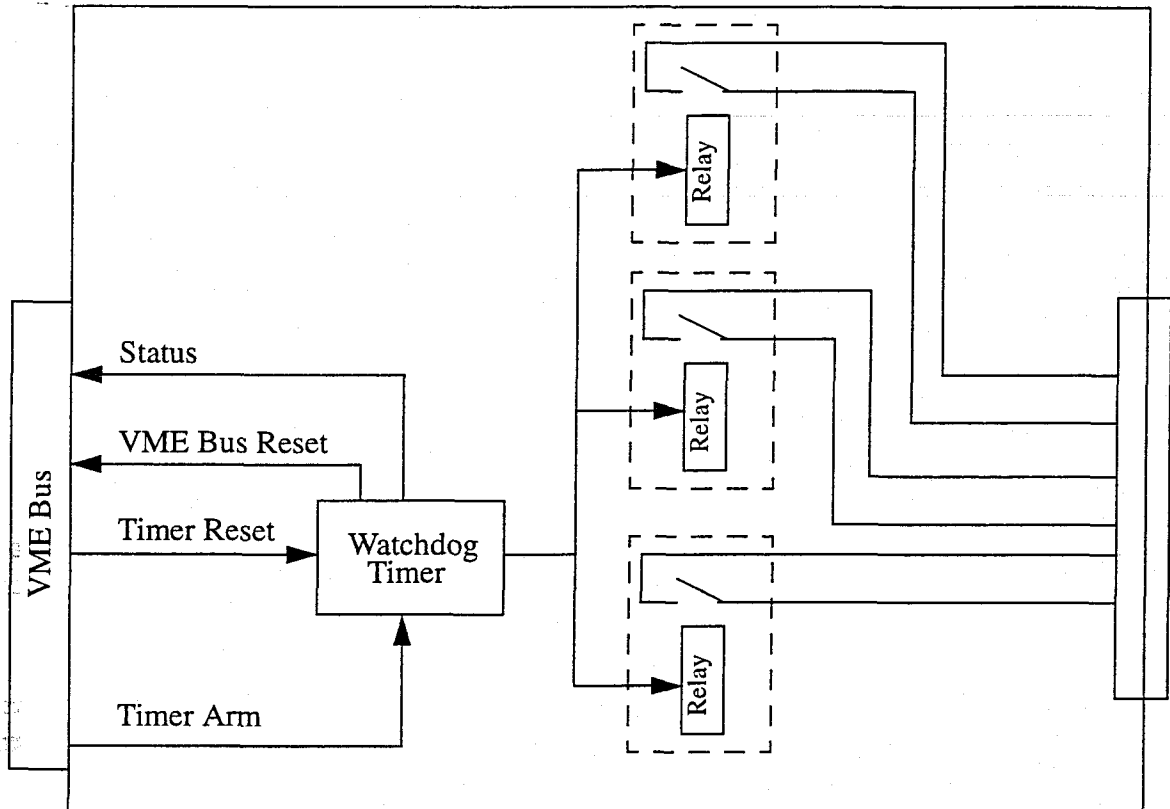

Figure 3: Watchdog Timer Module

In the specific case of the VCMS, the relay contacts of the watchdog timer are in series with:

- The open and close drive signals to the vacuum section isolation valves, such that these signals will be removed on a processor failure in the event the valve was being moved at the time of failure.
- Each cryopump regeneration heater control signal, such that the heater will turn off on processor fault.
- Each cryopump level control valve open/close signal, such that LN2 flow to the cryopump will be shut off on processor failure.

3.2.1.6 UPS

Each VCMS rack is supplied with a small UPS system to protect against power line surges and outages. These units are rated to operate the VME crate and 24VDC power supplies for a minimum of 15 minutes on power loss. The fact that a UPS is now the power source is detected by the VME processor and an alarm condition is set to notify operations staff.

3.2.2. Software

3.2.2.1 Overview

All software for VME processors in the VCMS will be developed and operated under the LIGO CDS standard real-time systems. This includes VxWorks as the operating system with EPICS real-time database and C code. Further information on these standards are described in *LIGO CDS Control and Monitoring Preliminary Design* LIGO-T960142-00-C.

3.2.2.2 Control and Monitoring Modules

All control and monitoring software on the VCMS processors will be developed in a re-usable, modular fashion. This will typically be by type of VE assembly (discussed in 3.3). For example, a standard code module will be developed which can operate and monitor a vacuum section isolation valve. This code will be identical for all such valves, with only the EPICS name tag fields and I/O point locations changed in each module to identify a specific instance of an isolation valve. Actual code module examples are shown in Appendix C. Further descriptions of these code modules are in Section 3.3.

3.2.2.3 Diagnostics

Various standard diagnostics exist in EPICS and VxWorks for monitoring of VCMS software, as described in *LIGO CDS Control and Monitoring Preliminary Design* LIGO-T960142-00-C. In addition, each VCMS subsystem processor will report health status to a central CDS processor on a periodic basis which may be viewed from a processor diagnostic display. Alarms will also be generated if a processor detects an internal software module fault or I/O hardware fault, or VCMS processors fail to respond in given time frames to requests from the central unit.

3.3. Assemblies

3.3.1. Beam Tubes

Each LIGO site contains four, 2km beam tubes. The VCMS is responsible for monitoring a Pirani/Cold Cathode gauge pair at the ends of each tube. In addition, during a pumpdown cycle, the VCMS must monitor signals from portable turbo pump carts when connected to the 10" pumpout ports at each end of the tubes¹.

3.3.1.1 Gauge Pairs

Typical wiring of the vacuum gauge pairs into the VCMS is shown in LIGO D0961342-00-C in Appendix A. Each gauge is connected to an ADC channel for monitoring by the local processor. Since these signals are also used in isolation valve interlocks (See section 3.3.6. Vacuum Section Isolation Valves), each gauge signal is also connected to the VME interlock module. Typical software for gauge pairs is shown in Appendix C, Figure 4. Display of information from beam tube vacuum gauges is incorporated into the various subsystem displays, as shown in Appendix B.

1. No monitoring is provided at Livingston site mid stations.

3.3.1.2 Turbo Pump Carts

To monitor turbo pump signals, additional cabling is provided. First, an umbilical is provided for each turbo pump cart, as shown in LIGO D961400-00-C in Appendix A. Each cable is keyed by unique jumpering of pins 21-24 to identify the turbo cart to the VCMS. When the pump cart is to be used, this umbilical plugs into a receptacle near the pumpout port. A cable from this receptacle in turn is connected to the nearest VCMS rack as shown in LIGO D961401-00-C in Appendix A. This is a permanent cable which plugs into a 50 pin connector of a Phoenix block, from which signals are then wired to binary input and ADC VME modules for monitoring by the VCMS as shown in LIGO D961399-00-C.

Separate displays are provided for viewing pump out port / portable pump cart information. An example prototype display pages is shown in Appendix B. The software involved in monitoring a pump cart is shown in Figures 6 and 7 of Appendix C. The software shown in Figure 6 of Appendix C is from WCP-5, but is basically the same for all pumpout ports, except that the pump port isolation valves in the beam tubes have no position indication (ZSC and ZSO340 in the software diagram).

3.3.2. Beam Manifolds

Beam manifolds are the sections of vacuum tube within LIGO buildings which connect various vacuum equipment. Within the mid and end stations, the only devices associated with the beam manifolds are 10" pumpout ports. At these locations, the VCMS provides for monitoring of turbo pump carts, as described in the previous section. In addition, these 10" pumpout ports have limit switches (open/closed) on the port gate valves, which are connected to and monitored by the VCMS.

At the LVEA, beam manifolds also contain annulus ion pumps and 6" pumpout ports, along with the 10" pumpout ports. For the ion pumps, the VCMS provides for monitoring of pump current.

The 6" pumpout ports are used for connection of portable roughing pump carts. Similar to turbo pump cart monitoring provided at 10" ports, the VCMS provides monitoring of the roughing pump carts when connected to the 6" ports. Again, an umbilical is provided for each roughing pump cart, which connects to a receptacle near the port. This cable is as shown in LIGO D961402-00-C. A permanent cable extends from these receptacles to the nearest VCMS rack and plugs into a 50 pin Phoenix connection block, with signals distributed from there to binary input and ADC channels of the VCMS. Wiring is also provided by PSI to VCMS racks for the monitoring of 6" pumpout port gate valve positions.

Software for monitoring of beam manifold equipment is similar to that shown in Appendix C, Figures 6 and 7.

3.3.3. 80K Cryopumps

There are a total of 8 cryopumps at Hanford and 4 at Livingston. Along with signal monitoring, the VCMS provides the following controls:

- LN2 level control.
- Control of regeneration temperature.

Typical signal wiring connections for a cryopump are shown in LIGO D961339-00-C in Appendix A.

3.3.3.1 Operator Displays

Three types of operator displays will be provided for viewing/operating cryopump parameters:

- Summary display, which displays key parameters from all cryopumps at a site.
- A detailed operating display, one for each cryopump, which depicts all parameters of each pump.
- Trend plots. Strip chart displays will be available for various parameters of these pumps for various operating modes, such as pressures during pumpdown, levels during fill and normal operations, and heater temperatures during regeneration.

Prototype examples of these pages are shown in Appendix B.

3.3.3.2 Level Control

The VCMS is to provide automatic level control for the LN2 within each cryopump. The overall procedure for initial filling and thereafter automatic control is outlined in PSI document *Operating Procedures 80K Pump for LIGO Vacuum Equipment*, LIGO-E960127-00-V. The following section uses WCP-5 at the Hanford midstation as an example for describing the controls, but all other cryopump controls are identical. Refer to Cryopump Display Panel example (Appendix B, Figure 8) and Cryopump Level Control Software in Appendix C, Figure 2 for the following level control discussion.

A simplified drawing of the level control for WCP-5 is shown in Figure 4: Cryopump Level Control Loop. LN2 is supplied by Dewar tanks located outside LIGO buildings. Piping provides the LN2 to the pump units, with the flow controlled by a flow control valve (LV-300). The pump housing is supplied with differential pressure transducers which provide a level indication (LT-300).

Two interfaces are provided by PSI for the VCMS to control the flow valve LV-300:

- LIC-300: A 4-20mA signal from VCMS which controls the amount of opening of the valve.
- XV-300: A binary (0 or 24VDC) input at the valve which closes the valve, regardless of the LIC-300 input signal.

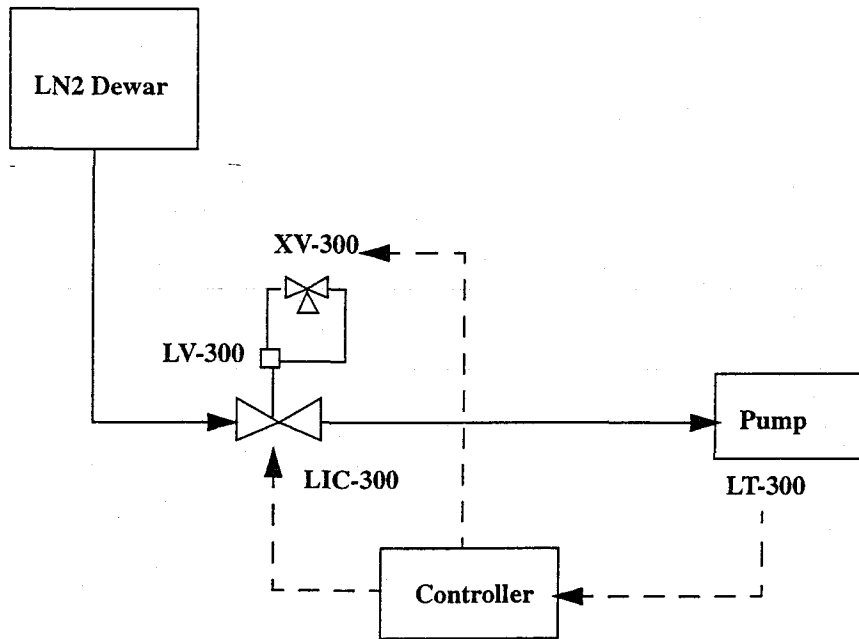

Figure 4: Cryopump Level Control Loop

3.3.3.2.1 Initial Fill

Initial fill of the pumps is accomplished through a manual operation of opening a bypass valve around the level control valve. Once the fill has reached ~75%, the VCMS is set to automatic level control by operating staff by selecting automatic on the operator control panel. Therefore, the VCMS provides for both manual and automatic control of the pump LN2 level, as described in the following sections.

3.3.3.2.2 Enabling the Flow Valve

Before manual or automatic level control can be accomplished via LT-300, it must be enabled (opened). This valve is allowed to open by operator command from the cryopump display panel. When requested to open, XV300OPEN (in the software diagram of Appendix C) in the local processor is set high. This is then sent to XV300INT, which verifies that the conditions are met for the valve to open. These conditions are:

- Vacuum is less than TBD, as read from the cryopump gauge pair and calculated by CP5_FILL.
- LN2 level in the Dewar is greater than the low alarm limit, as calculated by LT305LOW.
- The regeneration system is not on, as indicated by CP5_REGEN being low.

If these conditions are all met, then LV300 is set to OPEN by XV300. The amount the valve is opened is then controlled by LIC300.

3.3.3.2.3 Manual Control

Control of the LN2 level is set to Manual during initial fill and may be set to manual to override the automatic functions at the discretion of operators in accordance with LIGO operating procedures. Referring

to cryopump display panel (Appendix B, Figure 8) and the software diagram of Appendix C, the software process is:

- Operator selects "Manual" mode from the operator control panel. The operator also sets a control valve opening as % open. These selections are then transmitted to the EPICS records shown as LVLAUTO and LVLADJ in the subsystem processor.
- These signals are then fed into LVLSIG, which is a calculation record being used as a switch. If LVLAUTO is zero (Manual Mode), then LVLADJ is passed on to LIC300, which is the signal sent to LV300, the actual level control valve. LIC300 itself takes a % open request and converts it to a setting for the VCMS analog output module, which produces a 4-20mA signal which drives the valve.

3.3.3.2.4 Automatic Control

For automatic level control, a Proportional, Integral, Differential (PID) loop is incorporated into the software as LVLCTRL. Referring to the previous diagrams, the process is as follows:

- LN2 level is detected via a level transmitter (LT300 in the upper left hand corner of the software diagram). This signal is converted by the software to a % full and then passed on to the next software record (LVLCTRL) as the level readback.
- LVLCTRL is a PID loop record. The loop constants are adjustable from the operator display panel as Kp, Ki and Kd. This loop is to maintain a level (nominal 93%) within the cryopump.
- When the loop is set to AUTO by the operator, LVLAUTO is set to one, which causes LVLSIG to route the output of LVLCTRL to LIC300. This adjusts the actual level control valve, as described in the previous section.

3.3.3.2.5 Fault Protection

3.3.3.2.5.1 Power Loss or VCMS Failure

Should the VCMS lose power, the VCMS relay which allows the flow control valve and the watchdog timer relay will both deenergize, removing power from that valve and thereby stopping N2 flow into the pump. If the VCMS processor fails due to hardware or fatal software error, the flow valve will be closed by the watchdog timer relay going open.

3.3.3.2.5.2 Rise in Pump Vacuum or Overpressure

The software will continuously monitor the cryopump vacuum gauge pair and the discharge pressure. Should either rise beyond their alarm limits, the N2 flow control valve will be closed.

3.3.3.3 Regeneration Temperature Control

During regeneration, LN2 from the dewars is vaporized and then heated to purge the cryo panels in the pumps. The VCMS provides control of the heaters used in this process.

3.3.3.3.1 Electrical Connections

The typical wiring and interface to VCMS for regeneration is shown in D961339-00-C in Appendix A. Three thermocouples are supplied by PSI (TE303A thru TE303C, C being a spare of TE303B) and wired into VCMS ADC modules for monitoring temperatures. The VCMS supplies one 4-20mA output via a DAC channel which controls the regeneration heater unit supplied by PSI. This DAC signal is fed through

two additional relays before going to the heater unit. The first is controlled by the VCMS as an On/Off switch for regeneration. The second is a relay on the VCMS watchdog timer module.

3.3.3.3.2 *Software Monitoring and Control*

Regeneration heater monitoring and controls appear on the cryopump detail display pages as shown in Figure 8 of Appendix B. This includes the temperature readings, heater setpoint, regen permit and regen on/off select.

To start the regeneration heater, an operator enters a temperature setting (TY103) and turns on the heater from the display panel. Referring to the software diagram in Appendix C, Figure 3, the turn on sets REGENON high. This is fed into REGENINT, which verifies that conditions are acceptable to turn on the heater. This will have a TRUE output if and only if:

- The temperatures read by the thermocouples are below the high alarm limits
- The vacuum section isolation valves on both sides of the cryopump are closed, as indicated, in the case of WCP-5, ZSC309 and ZSC319.
- The LN2 level control valve is closed, as indicated by ZSC300 for WCP-5.

The output of REGENINT is then passed to REGENVAL and REGEN. REGEN operates a relay which allows an analog control signal to be sent to the heater unit. REGENVAL takes the operator temperature request (REGENSET) and passes it to TY303 if REGENINT is TRUE. TY303 sends a 4-20mA signal proportional to the temperature request to the heater unit.

3.3.3.3.3 *Fault Protection*

3.3.3.3.3.1 *Over Temperature*

If the regen temperature exceeds the high alarm limits, this will be sensed by REGENINT. This software record will automatically set REGEN low, thereby disabling the relay which allows the regen control signal to be sent. REGENVAL will also set TY303 to zero. The action of either of these will turn off the regen heater.

3.3.3.3.3.2 *VCMS Failure*

Should the VCMS processor system fail due to power loss, the relay controlled by REGEN will deenergize, thereby turning off the regen heater.

In the event that the VCMS processor controlling regeneration locks up due to a hardware failure or fatal software error, the watchdog timer module will time out. One of its relays passes the regen heater 4-20mA signal to the heater unit. This relay will deenergize, removing this signal and thereby turn off the heater unit.

3.3.3.4 *Discharge Line Monitoring*

The VCMS provides monitoring of the discharge line pressure, along with temperatures.

3.3.3.5 Dewar Level Monitoring

The VCMS receives a single reading from each dewar, namely the level indication. As shown in the software diagram in Appendix C, Figure 2, for WCP-5 this signal is LT305. The VCMS provides additional calculations derived from this level indication for display to operators as shown

- LNRATE: Calculates the consumption rate of LN2 from the dewar
- LNTTE: Estimates the time until the tank will be empty at the present consumption rate.

This information is displayed to operators as shown in Figure 7 and Figure 8 of Appendix B.

3.3.3.6 Gauge Pair Monitoring

Each cryopump has a Pirani/Cold Cathode gauge pair. These are monitored via connection to ADC channels. In addition, each signal is sent to an isolation valve interlock module.

3.3.3.7 10" Pumpout Port Monitoring

A 10" pumpout port is provided at each cryopump for the connection of portable turbo pump carts. Connection cabling and monitoring is as described for the beam manifolds in Section 3.3.1. Beam Tubes.

3.3.4. HAM Chambers

The VCMS provides for monitoring of current signals from HAM chamber annulus ion pumps.

3.3.5. Beam Splitter Chambers

All BSC contain annulus ion pumps, from which current is monitored by the VCMS. Certain designated BSC also contain guage pairs, which are monitored by the VCMS as described in previous sections.

3.3.6. Vacuum Section Isolation Valves

Large, 48" gate valves are used to isolate various sections of the vacuum system. The VCMS provides control for opening and closing these valves, as well as monitoring position and currents from annulus ion pumps.

Signal connections from typical isolation valves are as shown in D961344-00-C, included in Appendix B.

3.3.6.1 Design Changes

It should be noted that the design description for gate valve control which follows has two notable changes from the previous conceptual design:

1. An interlock key panel and local operation of valves from pushbuttons on the panel has been removed. The valve designs are now known, and have local operation capabilities built into them. Procedures will be developed by the LIGO facilities group to use those local controls, thereby not requiring a second set from the VCMS.
2. Conceptual design showed Programmable Logic Controllers (PLC) being used to verify gate valve interlocks independent of the VME processor. This has been replaced by a custom VME module, primarily to provide the same function at a lower cost.

3.3.6.2 Valve Opening

A personnel and equipment safety hazard exists if an isolation valve is opened with high vacuum on one side and atmospheric pressure on the other. To prevent opening a valve under such conditions, various interlocks are employed. Certain controls are procedural, such as mechanically locking valves and lock-out of valve control power. These procedures are covered under separate documentation.

The VCMS also provides two independent interlock schemes for each valve. A simplified view of the interlock chain for each valve is shown in Figure 5: Gate Valve Control Circuitry (Simplified View).

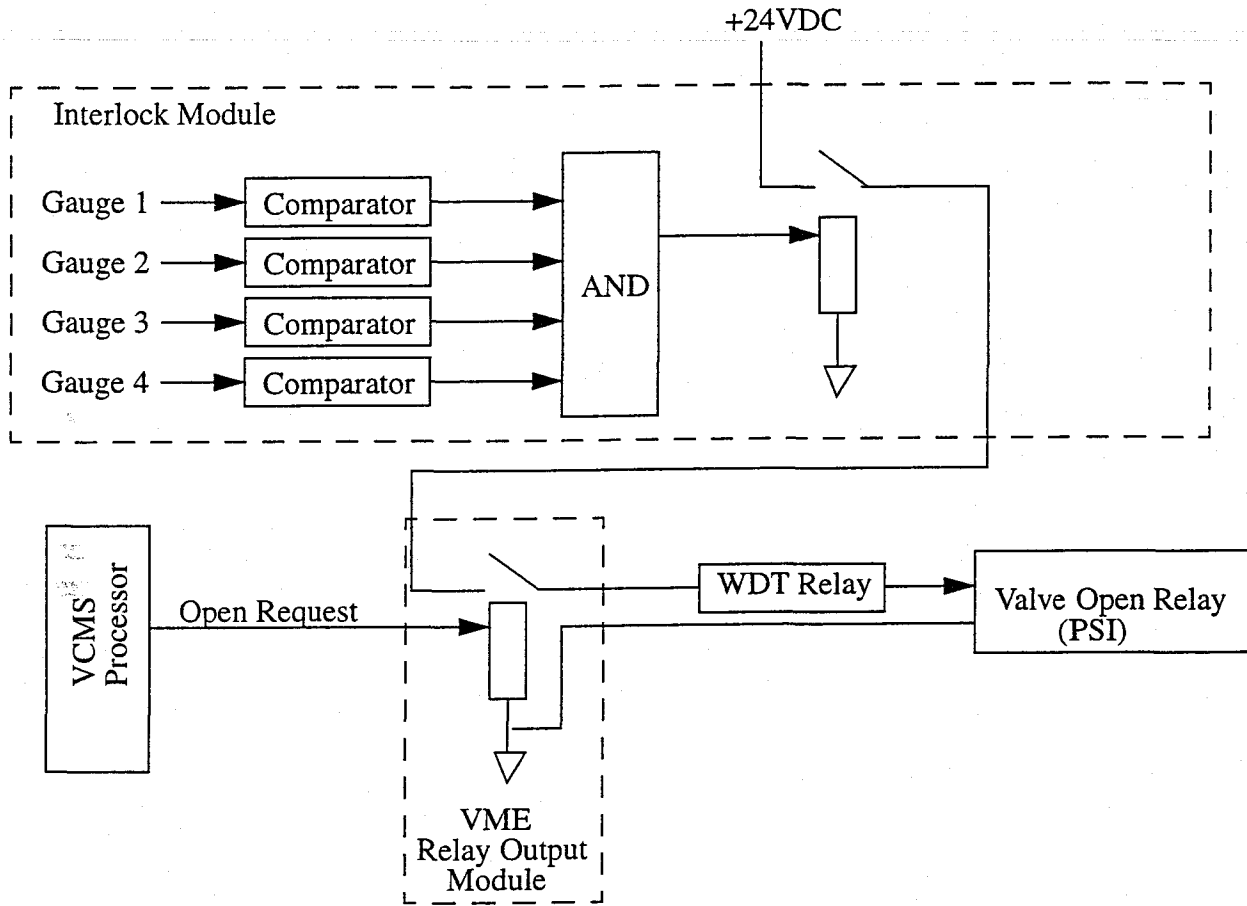

Figure 5: Gate Valve Control Circuitry (Simplified View)

First, each vacuum gauge signal is sent to a LIGO designed VME interlock module. The electrical design for this module is shown in Appendix D. This module provides a set of comparators, four for each valve, for the nearest up and down stream Pirani and Cold Cathode gauges. These comparators have a high output when and only when the monitored gauge signal reaches a high vacuum reading. The outputs of these comparators are then fed to an AND gate, which produces a high output and pulls in a relay contact when all four gauges are reading in the high vacuum range. As shown in Figure Figure 5: Gate Valve Control Circuitry (Simplified View), this relay contact is in series with the computer operated contact for energizing the valve relay which causes the valve to move in the open direction.

The VCMS subsystem processor provides the second half of the interlock chain. This is done in software, as shown in Appendix C, Figure 1, which details the software for WGV-13. This software consists of two parts: 1) a set of EPICS records and 2) C code written as an EPICS SNL program.

Four analog input (AI) records read in the gauge readings and convert them to engineering units (Torr). These are then fed to two calculation records (CALC) which produce a TRUE output whenever the readings are below the high vacuum setpoint. Another CALC record (HVE:MX:GV13_INT309) monitors readings from the gate valve annulus ion pump, the valve limits switches and the valve fault signal. In addition, if one of the 2500 l/s ion pumps is connected within the isolatable sections served by this valve, this signal is also sent to this record. If the annulus ion pump current and 2500 l/s ion pump current is in the normal range, the valve is not already open and there is no valve fault indicated, this CALC record has a TRUE output. The outputs from these intermediate CALC records then feed a final CALC record, which ANDs these previous signals together to provide a final interlock sum (HVE-MX:GV13_INTSUM).

The second part of the software involved is shown as a state transition diagram at the bottom right of the figure. This is C code wrapped in EPICS SNL, primarily to allow it to interact with EPICS records. This program sits in an idle state until an operator requests a valve to be opened. The opening sequence is as follows:

1. An operator requests that an isolation valve be opened through the use of an interactive icon on an operator display. This action causes record HVE-MX:GV13_HS309AR to be set TRUE.
2. The SNL code then transitions to the Interlock Check state. In this state, the SNL code verifies that the interlock sum record output is TRUE and that the VME interlock module is indicating that it has an interlock sum as well. If these conditions are not met, the SNL will send a fault message via record HVE-MX:GV13_SM309 to advise the operator that conditions are not met for opening the valve. It will also reset the Open Valve request by resetting HVE-MX:GV13_HS309AR to False and return to the IDLE state. If the interlock sums are all TRUE, the SNL code will transition to the Drive Open state.
3. In the Drive Open state, HVE-MX:GV13_HS309A is set TRUE, which closes a relay within the VME relay output module, which in turn supplies 24VDC to the relay at the valve which actually causes the valve to drive in the open direction. The SNL code remains in this state until either:
 - The valve open limit switch opens, at which point the SNL drops into the Delay state.
 - The operation is aborted by an operator, setting HVE:MX:GV13_HS309K to TRUE or a valve fault is detected by HVE-MX:GV13_XA309 going high. In this event, the SNL code goes directly to the Stop Drive state.
4. No action occurs in the delay state. This is simply a timeout, whereby the Open command continues for 1-2 seconds after the Open limit switch has been reached to ensure that the valve has seated in the open position. Once the timeout has elapsed, the SNL code drops into the Stop Drive state.
5. In the Stop Drive state, both the open (HVE-MX:GV13_HS309A) and close (HVE-MX:GV13_HS309B) are set False, thereby removing 24VDC from the valve actuator solenoids. The SNL code then returns to the IDLE state to await the next Open/Close command.

To close an isolation valve, the sequence is as follows:

1. An operator requests the valve to close via an interactive icon on a display screen. This causes HVE-

~~MX:GV13_HS309BR to be set TRUE.~~

2. In the IDLE state, the SNL code detects the setting of the close request. After checking for a valve fault indication (XA309), the SNL code goes to the drive closed state, where HS309B is set TRUE, causing the valve close relay to be energized and valve to move in the closed direction.
3. On hitting the CLOSE limit switch, the SNL continues to hold the drive energized for one second, then deenergizes the close relay by setting HS309B to zero, and returns to the IDLE start to await new commands.

3.3.7. 2500 l/s Ion Pumps

A total of twelve main ion pumps are to be installed at Hanford and six at Livingston. These are dual pump units, which require two separate turn on and turn off signals from the VCMS. The typical electrical connections for a main ion pump is shown in Appendix A D961345-00-C.

The software for a typical pump is shown in Appendix C, Figure 8. Monitoring and operation is allowed from various operator displays, as shown in Appendix B.

4 FABRICATION PLAN

4.1. Hardware

4.1.1. VCMS Racks

Assembly and integration of VCMS rack enclosures is to take place at the Hanford site within the storage building due for completion in March, 1997. The sequence is to be as follows:

1. Order rack enclosures and necessary power supplies in time for direct delivery to Hanford in March, 1997.
2. Order interconnect wiring components which fit in side area of racks and deliver to Caltech by January, 1997. Complete all interconnection wiring, VME module to interconnect wiring cables and pump cart monitoring cables at Caltech in time for shipment to Hanford by March 1997.
3. Bolt interconnect wiring frames into VCMS rack enclosures, along with power supplies and VME hardware March-April 1997.
4. Interconnect VCMS rack assemblies with CDS networking.

4.1.2. VME Equipment

Commercial VME equipment will be ordered and directly shipped to Hanford, with delivery by March 1997 for inclusion in the rack assembly described above.

The vacuum isolation valve interlock module and watchdog timer modules are in-house designs. The sequence for these are:

1. Prototype design (complete)
2. Build and test prototypes - November, 1997
3. Develop production designs - December, 1997
4. Place order and receive at Caltech - January, 1998

5. Test production models - February, 1998
6. Ship to Hanford for integration into VCMS rack enclosures - March, 1998

4.2. Software

Software for the VCMS is also to be developed by LIGO staff in two stages:

1. The first code developed will be EPICS/code modules for each assembly described in the previous sections. Each module will be tested to verify its operation on an assembly type. This work will be done at Caltech, with completion in January, 1997.
2. A software group extension of the CDS group will be established at Hanford in February, March 1997. This group will take on the task of replicating the base code modules for all instances of VE assemblies and the final software integration.

All software development will be accomplished in accordance with the *CDS Software Development Plan* LIGO T960004-C.

5 TEST PLAN

Interconnection cabling which fits in the sides of the VCMS racks will be point to point tested as it is built at Caltech prior to shipment to Hanford.

At Hanford, VCMS racks are to be tested as complete units, both hardware and software, as they are assembled. Signals in the ranges specified by PSI will be injected at all PSI interface points and traced through the system. Likewise, all output channels of the VCMS will be measured and calibrated at the PSI interfaces.

As all individual rack/subsystem tests are completed, all racks will be interconnected, as in the final configuration, with CDS networks. Testing will then be done to ensure that all VCMS components operate as an integrated system.

Once the system is installed, LIGO staff will support further testing with PSI for acceptance of the entire VE system.

6 INSTALLATION PLAN

Once the racks are assembled and tested at Hanford, they will be installed as complete units into the designated VE building areas. The only remaining installation work by LIGO staff will be connection of AC power and ground lines, and the cabling for the pump carts from the racks to the area of the pumpout ports. All additional wiring is to be performed by PSI.

Those VCMS racks destined for the Livingston site will be crated and shipped for installation when that facility is ready for the racks to be put in place.

APPENDIX A: ELECTRICAL DRAWINGS

This appendix contains a sampling of VCMS electrical drawings, primarily from the Hanford right mid-station, as a representative overview of electrical connections for major VE assemblies.

1. Table of VCMS Electrical Drawings (Complete Hanford site list)
2. VCMS system overview
3. Typical rack and VME crate layout
4. Portable pumping cart cabling
5. WCP-5 (80K Pump)
6. BSC-5 (Typical beam splitter chamber)
7. Beam tube gauge pairs
8. Manifold Pumpout Port w/turbo pump cart monitoring connections
9. Vacuum Section Isolation Valve connections
10. WIP-10 (Representative 2500 l/s ion pump connections)

Notes:

1. *Termination numbers for connections to VMIC2232 relay modules are not correct; waiting module manual to update numbering.*
2. *Watchdog timer module connections not fully incorporated pending module design.*

APPENDIX B: EXAMPLE OPERATOR DISPLAY PANELS

1. VCMS Overview Panel
2. Hanford Vertex Section
3. Hanford Diagonal Section
4. Hanford Right Midstation
5. Hanford Right End Station
6. Isolation Valve Detail
7. 80K Pump Overview
8. 80K Pump Detail
9. Pumpout Port
10. Trend Plot
11. VCMS Diagnostics

APPENDIX C: SOFTWARE DIAGRAMS

This appendix contains representative EPICS software diagrams of Hanford right midstation assemblies.

1. WGV-13 Control Software
2. WCP-5 Level Control
3. WCP-5 Regeneration Control
4. MX Beam Tube gauges
5. WBSC-5
6. WCP-5 Pumpout Port and Turbo Cart Monitoring
7. Pump Cart Hours Monitoring
8. WIP-5 2500 l/s Ion Pump

**APPENDIX D: VACUUM SECTION ISOLATION VALVE
INTERLOCK MODULE DESIGN**

APPENDIX A: ELECTRICAL DRAWINGS

This appendix contains a sampling of VCMS electrical drawings, primarily from the Hanford right mid-station, as a representative overview of electrical connections for major VE assemblies.

1. Table of VCMS Electrical Drawings (Complete Hanford site list)
2. VCMS system overview
3. Typical rack and VME crate layout
4. Portable pumping cart cabling
5. WCP-5 (80K Pump)
6. BSC-5 (Typical beam splitter chamber)
7. Beam tube gauge pairs
8. Manifold Pumpout Port w/turbo pump cart monitoring connections
9. Vacuum Section Isolation Valve connections
10. WIP-10 (Representative 2500 l/s ion pump connections)

Notes:

1. *Termination numbers for connections to VMIC2232 relay modules are not correct; waiting module manual to update numbering.*
2. *Watchdog timer module connections not fully incorporated pending module design.*

VACCUUM DRAWING LOG

<u>ITEM</u>	<u>TEMP FILE NAME</u>	<u>DESCRIPTION</u>	<u>SHT NO</u>	<u>NEW FILE NAME</u>	<u>DWG NO.</u>
		<i>MECHANICAL ROOM</i>			
1	rackme.dwg	ASSEMBLY, VCMS RACK WA MECHANICAL ROOM	1		D961305C
2	rack2me.dwg	ASSEMBLY, VCMS RACK WA MECHANICAL ROOM	FILE 2 SHT'S 1 THRU 5		D961306C
3	mesysdi.dwg	SYSTEM DIAGRAM MECHANICAL ROOM	1		D961307C
4	waiome_1.dwg	VCMS ELECTRICAL DIAGRAM WASHINGTON MECHANICAL ROOM WA ION PUMP - 01	1		D961308C
5	waiome_2.dwg	VCMS ELECTRICAL DIAGRAM WASHINGTON MECHANICAL ROOM WA ION PUMP - 02	1		D961309C
6	waiome_3.dwg	VCMS ELECTRICAL DIAGRAM WASHINGTON MECHANICAL ROOM WA ION PUMP - 03	1		D961310C
7	waiome_4.dwg	VCMS ELECTRICAL DIAGRAM WASHINGTON MECHANICAL ROOM WA ION PUMP - 04	1		D961311C
8	waiome_5.dwg	VCMS ELECTRICAL DIAGRAM WASHINGTON MECHANICAL ROOM WA ION PUMP - 05	1		D961312C
9	waiome_6.dwg	VCMS ELECTRICAL DIAGRAM WASHINGTON MECHANICAL ROOM WA ION PUMP - 06	1		D961313C

VACCUUM DRAWING LOG

10	waiome_7.dwg	VCMS ELECTRICAL DIAGRAM WASHINGTON MECHANICAL ROOM WA ION PUMP - 07	1		D961314C
11	waiome_8.dwg	VCMS ELECTRICAL DIAGRAM WASHINGTON MECHANICAL ROOM WA ION PUMP - 08	1		D961315C
12	vcpp_1.dwg	VCMS ELECTRICAL DIAGRAM WASHINGTON MECHANICAL ROOM VERTEX CHAMBER & PUMP PORT	1		D961316C
13					D961317C
14					D961318C

VACCUUM DRAWING LOG

		<u>X ARM</u>			
15	rackxarm.dwg	ASSEMBLY, VCMS RACK WA LVEA X ARM	FILE 2 SHT'S 1 THRU 5		D961319C
16	rk2xarm.dwg	ASSEMBLY, VCMS RACK WA LVEA X ARM	FILE 2 SHT'S 6,7		D961320C
17	sysdxarm.dwg	VCMS SYSTEM DIAGRAM WA LVEA X ARM	1		D961321C
18	wcp2_1.dwg	VCMS ELECTRICAL DIAGRAM WA LVEA X ARM WCP2	1		D961322C
19	wcp2_2.dwg	VCMS ELECTRICAL DIAGRAM WA LVEA X ARM WCP2	2		D961323C
20	gvc_1x.dwg	VCMS ELECTRICAL DIAGRAM WA LVEA X ARM GATE VALVE CONTROL	1		D961324C
21	gvc_2x.dwg	VCMS ELECTRICAL DIAGRAM WA LVEA X ARM GATE VALVE CONTROL	2		D961325C
22	wbsc4_1.dwg	VCMS ELECTRICAL DIAGRAM WA LVEA Y ARM WBSC-4	1		D961326C
23	wbsc7_1.dwg	VCMS ELECTRICAL DIAGRAM WA LVEA Y ARM WBSC-7	1		D961327C
24					D961328C
25					D961329C
26					D961330C

VACCUUM DRAWING LOG

		<u>Y ARM</u>			
27	rackyarm.dwg	ASSEMBLY, VCMS RACK WA LVEA Y ARM	FILE 2 SHT'S 1 THRU 5		D961331C
28	rk2yarm.dwg	ASSEMBLY, VCMS RACK WA LVEA Y ARM	FILE 2 SHT'S 6,7		D961332C
29	sysdyarm,.dwg	VCMS SYSTEM DIAGRAM WA LVEA Y ARM	1		D961333C
30	wcpl_1.dwg	VCMS ELECTRICAL DIAGRAM WA LVEA Y ARM wcp1	1		D961334C
31	wcpl_2.dwg	VCMS ELECTRICAL DIAGRAM WA LVEA Y ARM wcp1	2		D961335C
32	gvc_1y.dwg	VCMS ELECTRICAL DIAGRAM WA LVEA Y ARM GATE VALVE CONTROL	1		D961336C
33	gvc_2y.dwg	VCMS ELECTRICAL DIAGRAM WA LVEA Y ARM GATE VALVE CONTROL	2		D961337C
34	wbsc2_1.dwg	VCMS ELECTRICAL DIAGRAM WA LVEA Y ARM WBS-2	1		D961338C
35	wbsc8_1.dwg	VCMS ELECTRICAL DIAGRAM WA LVEA Y ARM WBS-8	1		D961339C
36					D961340C
37					D961341C
38					D961342C

VACCUUM DRAWING LOG

		<i>RIGHT MID STATION</i>			
39	rackrms.dwg	ASSEMBLY, VCMS RACK WA RIGHT MID STATION	FILE 2 SHT'S 1 THRU 5		D961343C
40	rack2rms.dwg	ASSEMBLY, VCMS RACK WA RIGHT MID STATION	FILE 2 SHT'S 6,7		D961344C
41	sysdirms.dwg	VCMS SYSTEM DIAGRAM WA RIGHT MID STATION	1		D961345C
42	wcp5_1.dwg	VCMS ELECTRICAL DIAGRAM WA RIGHT MID STATION WCP5	1		D961346C
43	wcp5_2.dwg	VCMS ELECTRICAL DIAGRAM WA RIGHT MID STATION WCP5	2		D961347C
44	wbsc5_1.dwg	VCMS ELECTRICAL DIAGRAM WA RIGHT MID STATION WBSC - 5	1		D961348C
45	wcp6_1.dwg	VCMS ELECTRICAL DIAGRAM WA RIGHT MID STATION WCP6	1		D961349C
46	wcp6_2.dwg	VCMS ELECTRICAL DIAGRAM WA RIGHT MID STATION WCP6	2		D961350C
47	rbtgp_1.dwg	VCMS ELECTRICAL DIAGRAM WA RIGHT MID STATION BEAM TUBE GUAGE PAIRS	1		D961351C
48	rmpp_1.dwg	VCMS ELECTRICAL DIAGRAM WA RIGHT MID STATION MANIFOLD PUMP PORT	1		D961352C
49	gvc_1.dwg	VCMS ELECTRICAL DIAGRAM WA RIGHT MID STATION GATE VALVE CONTROLE	1		D961353C
50	gvc_2.dwg	VCMS ELECTRICAL DIAGRAM WA RIGHT MID STATION GATE VALVE CONTROLE	2		D961354C

VACCUUM DRAWING LOG

51	waiome_9.dwg	VCMS ELECTRICAL DIAGRAM WASHINGTON MECHANICAL RM WA ION PUMP - 09	1		D961355C
52					D961356C
53					D961357C
54					D961358C
55					D961359C
56					D961360C

VACCUUM DRAWING LOG

		<u>LEFT MID STATION</u>			
57	racklms.dwg	ASSEMBLY, VCMS RACK WA LEFT MID STATION	FILE 2 SHT'S 1 thru 5		D961361C
58	rack2lms.dwg	ASSEMBLY, VCMS RACK WA LEFT MID STATION	FILE 2 SHT'S 6,7		D961362C
59	sysdilms.dwg	VCMS SYSTEM DIAGRAM WA LEFT MID STATION	1		D961363C
60	wcp3_1.dwg	VCMS ELECTRICAL DIAGRAM WA LEFT MID STATION WCP3	1		D961364C
61	wcp3_2.dwg	VCMS ELECTRICAL DIAGRAM WA LEFT MID STATION WCP3	2		D961365C
62	wcp4_1.dwg	VCMS ELECTRICAL DIAGRAM WA LEFT MID STATION WCP4	1		D961366C
63	wcp4_2.dwg	VCMS ELECTRICAL DIAGRAM WA LEFT MID STATION WCP4	2		D961367C
64	lbtgp_1.dwg	VCMS ELECTRICAL DIAGRAM WA LEFT MID STATION BEAM TUBE GUAGE PAIRS	1		D961368C
65	lmpp_1.dwg	VCMS ELECTRICAL DIAGRAM WA LEFT MID STATION MANIFOLD PUMP PORT	1		D961369C
66	gvc_1lm.dwg	VCMS ELECTRICAL DIAGRAM WA LEFT MID STATION GATE VALVE CONTROL	1		D961370C
67	gvc_2lm.dwg	VCMS ELECTRICAL DIAGRAM WA LEFT MID STATION GATE VALVE CONTROL	2		D961371C
68	wbsc6_1.dwg	VCMS ELECTRICAL DIAGRAM WA LEFT MID STATION WBSC-6	1		D961372C

VACCUUM DRAWING LOG

69	waiome10.dwg	VCMS ELECTRICAL DIAGRAM WALEFT MID STATION WA ION PUMP - 10	1		D961373C
70					D961374C

VACCUUM DRAWING LOG

		<u>LEFT END STATION</u>			
71	rackles.dwg	ASSEMBLY, VCMS RACK WA LEFT END STATION	FILE 2 SHT'S 1 THRU 5		D961375C
72	rack2les.dwg	ASSEMBLY, VCMS RACK WA LEFT END STATION	FILE 2 SHT'S 6,7		D961376C
73	sysdilms.dwg	VCMS SYSTEM DIAGRAM WA LEFT END STATION	1		D961377C
74	gvc_1le.dwg	VCMS ELECTRICAL DIAGRAM WA LEFT END STATION GATE VALVE CONTROL	1		D961378C
75	lbt_1.dwg	VCMS ELECTRICAL DIAGRAM WA LEFT END STATION BEAM TUBE	1		D961379C
76	wcp7_1.dwg	VCMS ELECTRICAL DIAGRAM WA LEFT END STATION WCP7	1		D961380C
77	wcp7_2.dwg	VCMS ELECTRICAL DIAGRAM WA LEFT END STATION WCP7	2		D961381C
78	wbsc_10.dwg	VCMS ELECTRICAL DIAGRAM WA LEFT END STATION WBSC-10	1		D961382C
79	waiome11.dwg	VCMS ELECTRICAL DIAGRAM WA RIGHT END STATION WA ION PUMP - 1 1	1		D961383C
80					D961384C
81					D961385C
82					D961386C

VACCUUM DRAWING LOG

		RIGHT END STATION			
83	rackres.dwg	ASSEMBLY, VCMS RACK WA RIGHT END STATION	FILE 2 SHT'S 1 thru 5		D961387C
84	rack2res.dwg	ASSEMBLY, VCMS RACK WA RIGHT END STATION	FILE 2 SHT'S 6,7		D961388C
85	sysdirms.dwg	VCMS SYSTEM DIAGRAM WA LEFT END STATION	1		D961389C
86	gvc-1 re.dwg	VCMS ELECTRICAL DIAGRAM WA RIGHT END STATION GATE VALVE CONTROL	1		D961390C
87	rbt_1.dwg	VCMS ELECTRICAL DIAGRAM WA RIGHT END STATION BEAM TUBE	1		D961391C
88	wcp8_1.dwg	VCMS ELECTRICAL DIAGRAM WA RIGHT END STATION WCP8	1		D961392C
89	wcp8_2.dwg	VCMS ELECTRICAL DIAGRAM WA RIGHT END STATION WCP8	2		D961393C
90	wbsc_9.dwg	VCMS ELECTRICAL DIAGRAM WA LEFT END STATION WBSC-9	1		D961394C
91	waiome12.dwg	VCMS ELECTRICAL DIAGRAM WA RIGHT END STATION WA ION PUMP - 12	1		D961395C
92					D961396C
93					D961397C
94					D961398C

VACCUUM DRAWING LOG

		<u>MICELLANEOUS</u>			
95	vacl.dwg	WIRING DIAGRAM	1		D961399C
96					D961400C
97					D961401C
98					D961402C
99					D961403C
100					D961404C

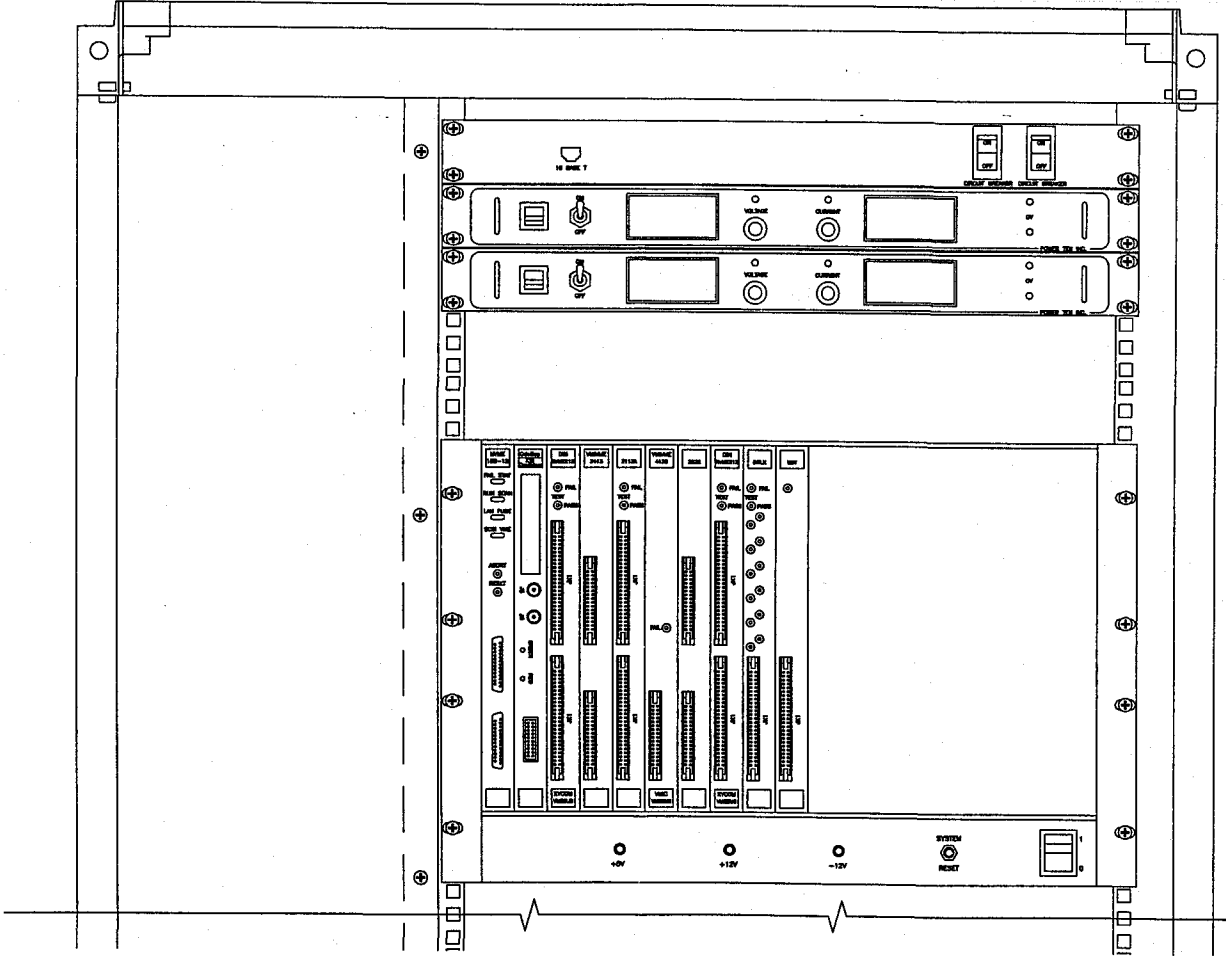

VME MODULE TABLE	
SLOT #	MODULE NAME
SLOT 0	MVME 162-12
SLOT 1	GPS
SLOT 2	XY212
SLOT 3	3413
SLOT 4	3113A
SLOT 5	4120
SLOT 6	2232
SLOT 7	XY212
SLOT 8	INTLK
SLOT 9	WDT

UNLESS OTHERWISE SPECIFIED DIMENSIONS ARE IN INCHES TOLERANCES FRACTIONAL & DECIMALS ARE TO BE SHOWN TO THREE PLACE DECIMALS DIMENSIONS TO BE SHOWN TO THREE PLACE DECIMALS FINISHED SURFACE DIMENSIONS TO BE SHOWN TO THREE PLACE DECIMALS REMOVE ALL BURRS		CURRENT REVISION APPROVAL		LIGO CALIFORNIA INSTITUTE OF TECHNOLOGY MASSACHUSETTS INSTITUTE OF TECHNOLOGY	
DO NOT SCALE THIS DRAWING		DRAWN TERRY T. CHECKED	GROUP CIS	SIGNATURE	DATE 9-11-96
DWG. NO.	DESCRIPTION	REV.	DESCRIPTION	SHEETS EFFECTED	DATE
REFERENCE DRAWINGS		ISSUE DESCRIPTION		SCALE B D961337-00-C SHEET 5 OF 7	

1337S1CO
10-23-96 - 08:13

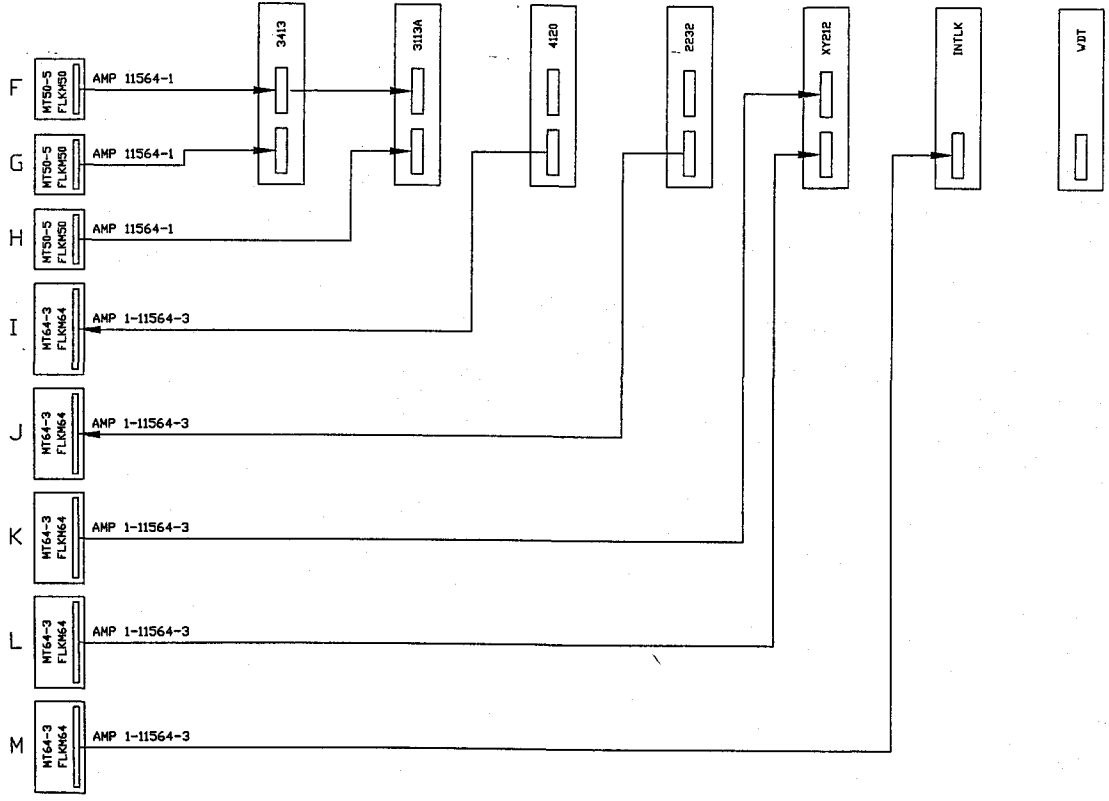
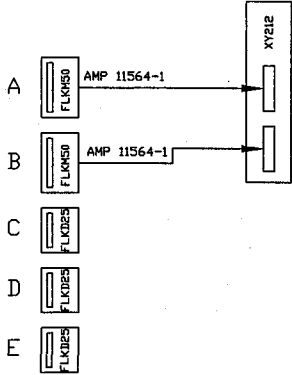
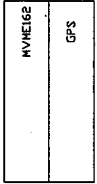

				UNLESS OTHERWISE SPECIFIED DIMENSIONS ARE IN INCHES				CURRENT REVISION APPROVAL		LIGO CALIFORNIA INSTITUTE OF TECHNOLOGY MASSACHUSETTS INSTITUTE OF TECHNOLOGY	
				TO CHECKER FUNCTIONAL & MECHANICAL APPROX & SEND TO THE PLACER REGIONAL & FEDERAL SERVICE AND FROM CHECKER TO RECEIVE ALL BARS				CHECKED TONY T.		DATE 9-13-96	
				DO NOT SCALE THIS DRAWING				DESIGNED		SCALE	
DWG. NO.		DESCRIPTION		REV		ISSUE DESCRIPTION		SHEETS EFFECTED		DATE	
6		REFERENCE DRAWINGS		5		4		3		2	
								DRA FILE		SHEET 1 OF 1	
								D961338-00-C		REV: 00	

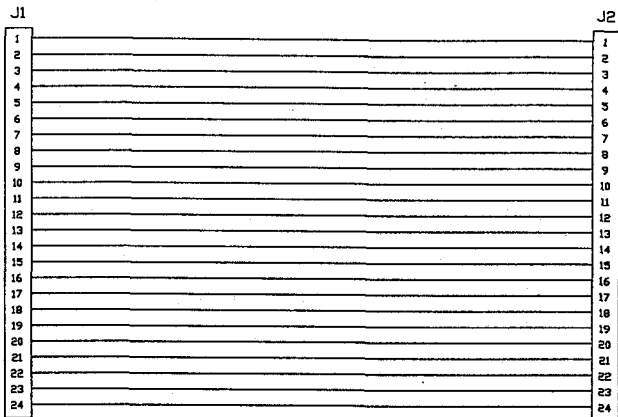

J1	SIGNAL	J2
1	QDP80 PUMP RUNNING	1
2	QDP80 PUMP RUNNING	2
3	QDP80 PUMP TEMP HAZARD	3
4	QDP80 PUMP TEMP HAZARD	4
5	STP200C PUMP ACCELERATION	5
6	STP200C PUMP ACCELERATION	6
7	N2 FLOW WARNING	7
8	N2 FLOW WARNING	8
9	STP200C TURBO PUMP NORMAL	9
10	STP200C TURBO PUMP NORMAL	10
11	PV40PK SAFTY VALVE OPEN	11
12	PV40PK SAFTY VALVE OPEN	12
13	PV40PK SAFTY VALVE CLOSED	13
14	PV40PK SAFTY VALVE CLOSED	14
15	COLD CATHODE GUAGE 0-10 VDC	15
16	COLD CATHODE GUAGE 0-10 VDC	16
17	PIRANI GUAGE 0-10 VDC A1	17
18	PIRANI GUAGE 0-10 VDC A1	18
19	GUAGE 0-10 VDC A2	19
20	GUAGE 0-10 VDC A2	20
21	"	21
22	"	22
23	"	23
24	"	24

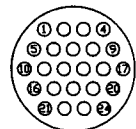
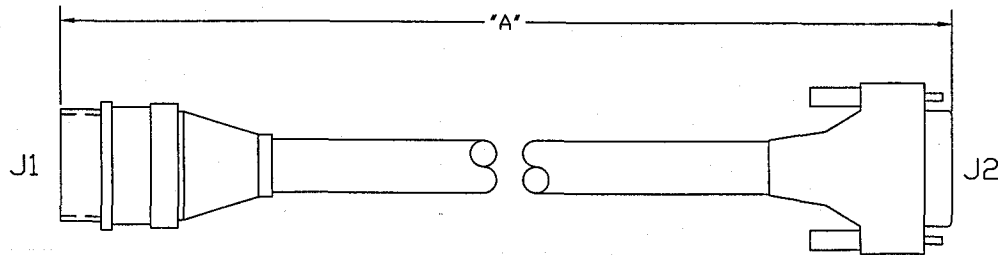

REF DES	CONNECTORS	CONTACTS	BACK SHELL
J1	AMP 206838-1	AMP 66105-2	AMP 206138-1
J2	AMP 748051-1		
CABLE LENGTH			
"A"	"	"	"

ENG. NO.	DESCRIPTION	ENG. NO.	DESCRIPTION	DATE	REV.	DESCRIPTION	DATE	REV.	DESCRIPTION	DATE	REV.	DESCRIPTION

NO	DATE	BY	CHKD	APP'D	REV.	DESCRIPTION

NO	DATE	BY	CHKD	APP'D	REV.	DESCRIPTION

NO	DATE	BY	CHKD	APP'D	REV.	DESCRIPTION

100 NATIONAL BUREAU OF TECHNOLOGY
 SUBSIDIARY BUREAU OF TECHNOLOGY
 VIMS ELECTRICAL DRAWING
 PUMP CART
 INTERFACE CABLE

NO FILE C D961401-00-C 00
 SHEET 1 OF 1

1401SCD
 10-23-96 - 11:41

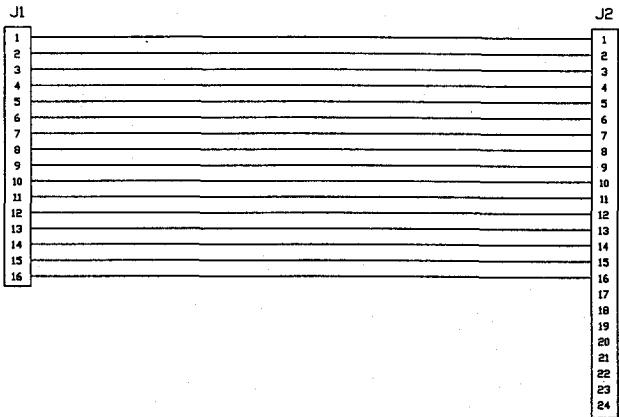

J1	SIGNAL	J2
1	EDP 200 PUMP RUNNING	1
2	EDP 200 PUMP RUNNING	2
3	EDP 200 PUMP TEMP HAZARD	3
4	EDP 200 PUMP TEMP HAZARD	4
5	EH 2600 BOOSTER RUNNING	5
6	EH 2600 BOOSTER RUNNING	6
7	INLET GATE VALVE CLOSED	7
8	INLET GATE VALVE CLOSED	8
9	INLET GATE VALVE OPEN	9
10	INLET GATE VALVE OPEN	10
11	N2 FLOW WARNING	11
12	N2 FLOW WARNING	12
13	PIRANI GUAGE 0-10 VDC A1	13
14	PIRANI GUAGE 0-10 VDC A1	14
15	GUAGE 0-10 VDC A2	15
16	GUAGE 0-10 VDC A2	16
		17
		18
		19
		20
		21
		22
		23
		24

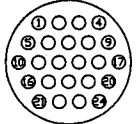
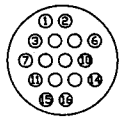
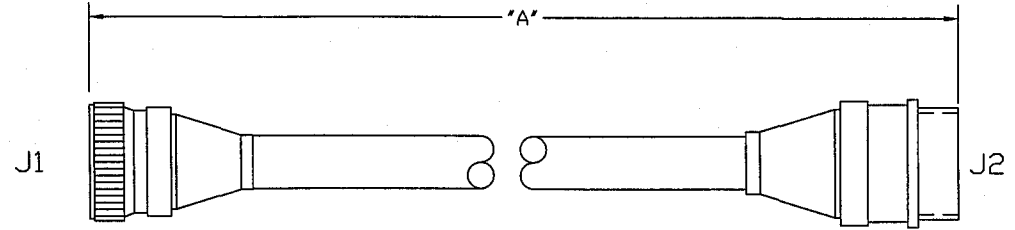

REF DES	CONNECTORS	CONTACTS	BACK SHELL
J1	AMP 206036-1	AMP 66105-2	AMP 206138-1
J2	AMP 206837-2	AMP 66105-2	AMP 206138-1
CABLE LENGTH			
"A"	-		

REV	DATE	BY	CHKD	APP'D	DESCRIPTION

REV	DATE	BY	CHKD	APP'D	DESCRIPTION

REV	DATE	BY	CHKD	APP'D	DESCRIPTION

REV	DATE	BY	CHKD	APP'D	DESCRIPTION

REV	DATE	BY	CHKD	APP'D	DESCRIPTION

REV	DATE	BY	CHKD	APP'D	DESCRIPTION

REV	DATE	BY	CHKD	APP'D	DESCRIPTION

REV	DATE	BY	CHKD	APP'D	DESCRIPTION

REV	DATE	BY	CHKD	APP'D	DESCRIPTION

REV	DATE	BY	CHKD	APP'D	DESCRIPTION

REV	DATE	BY	CHKD	APP'D	DESCRIPTION

REV	DATE	BY	CHKD	APP'D	DESCRIPTION

REV	DATE	BY	CHKD	APP'D	DESCRIPTION

REV	DATE	BY	CHKD	APP'D	DESCRIPTION

REV	DATE	BY	CHKD	APP'D	DESCRIPTION

REV	DATE	BY	CHKD	APP'D	DESCRIPTION

REV	DATE	BY	CHKD	APP'D	DESCRIPTION

REV	DATE	BY	CHKD	APP'D	DESCRIPTION

REV	DATE	BY	CHKD	APP'D	DESCRIPTION

REV	DATE	BY	CHKD	APP'D	DESCRIPTION

REV	DATE	BY	CHKD	APP'D	DESCRIPTION

REV	DATE	BY	CHKD	APP'D	DESCRIPTION

REV	DATE	BY	CHKD	APP'D	DESCRIPTION

REV	DATE	BY	CHKD	APP'D	DESCRIPTION

REV	DATE	BY	CHKD	APP'D	DESCRIPTION

REV	DATE	BY	CHKD	APP'D	DESCRIPTION

REV	DATE	BY	CHKD	APP'D	DESCRIPTION

REV	DATE	BY	CHKD	APP'D	DESCRIPTION

REV	DATE	BY	CHKD	APP'D	DESCRIPTION

REV	DATE	BY	CHKD	APP'D	DESCRIPTION

REV	DATE	BY	CHKD	APP'D	DESCRIPTION

REV	DATE	BY	CHKD	APP'D	DESCRIPTION

REV	DATE	BY	CHKD	APP'D	DESCRIPTION

REV	DATE	BY	CHKD	APP'D	DESCRIPTION

REV	DATE	BY	CHKD	APP'D	DESCRIPTION

REV	DATE	BY	CHKD	APP'D	DESCRIPTION

REV	DATE	BY	CHKD	APP'D	DESCRIPTION

REV	DATE	BY	CHKD	APP'D	DESCRIPTION

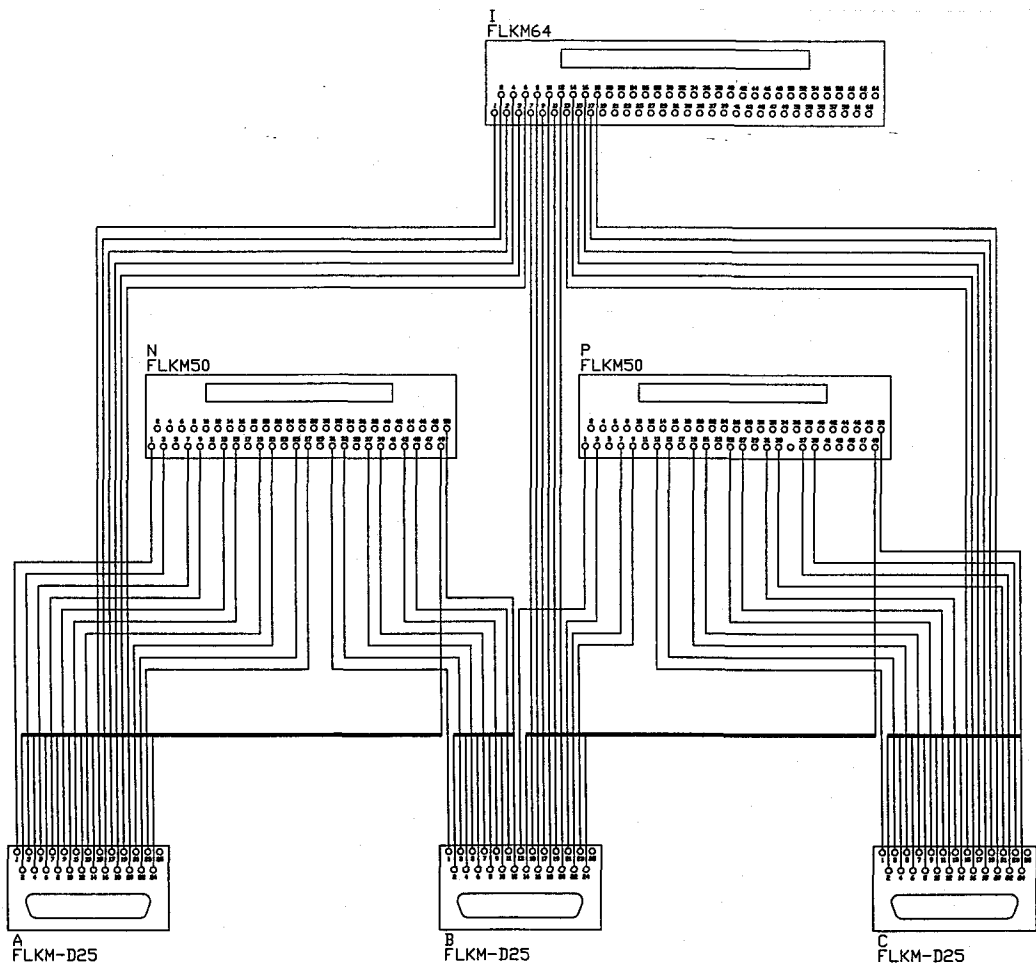

				UNLESS OTHERWISE SPECIFIED DIMENSIONS ARE IN INCHES TOLERANCES FINISHES HOLE LOCATIONS & HOLE Ø THIS PLACE SECOND & THIRD PLACE DECIMALS FINISHES SHOWN IN PARENTHESIS IN DRAWING SHALL BE USED UNLESS NOTED OTHERWISE				CURRENT REVISION APPROVAL DRAWN: TONY T. CHECKED: [] DATE: 02-04-96 GROUP: [] DESIG: [] SIGNATURE: []				MIT CALIFORNIA INSTITUTE OF TECHNOLOGY MASSACHUSETTS INSTITUTE OF TECHNOLOGY VCM'S ELECTRICAL DRAWING PUMP CART CABLE / VME INTERFACE WIRING			
DO NOT SCALE THIS DRAWING				REV				SHEETS EFFECTED				DATE			
DWG. NO.		DESCRIPTION		DWG. NO.		DESCRIPTION		USED ON		ISSUE DESCRIPTION		SHEETS		DATE	
6		REFERENCE DRAWINGS		5		NEXT ASSY:		4		3		2		1	
												SCALE: [] CAB FILE: [] SHEET: []		D961399-00-C 1 OF 8	

1399STCO
 10-22-96 - 07:51

PUMP CART #1				PUMP CART #2				PUMP CART #3			
FROM	SIGNAL	TO	COLOR	FROM	SIGNAL	TO	COLOR	FROM	SIGNAL	TO	COLOR
A1	QDP80 PUMP RUNNING	N1		B1	QDP80 PUMP RUNNING	N31		C1	QDP80 PUMP RUNNING	P13	
A2	QDP80 PUMP RUNNING	N49		B2	QDP80 PUMP RUNNING	N50		C2	QDP80 PUMP RUNNING	P50	
A3	QDP80 PUMP TEMP HAZARD	N3		B3	QDP80 PUMP TEMP HAZARD	N33		C3	QDP80 PUMP TEMP HAZARD	P15	
A4	QDP80 PUMP TEMP HAZARD	N49		B4	QDP80 PUMP TEMP HAZARD	N50		C4	QDP80 PUMP TEMP HAZARD	P50	
A5	SIP200C PUMP ACCELERATION	N7		B5	STP200C PUMP ACCELERATION	N37		C5	SIP200C PUMP ACCELERATION	P19	
A6	SIP200C PUMP ACCELERATION	N49		B6	STP200C PUMP ACCELERATION	N50		C6	SIP200C PUMP ACCELERATION	P50	
A7	N2 FLOW WARNING	N9		B7	N2 FLOW WARNING	N39		C7	N2 FLOW WARNING	P21	
A8	N2 FLOW WARNING	N49		B8	N2 FLOW WARNING	N50		C8	N2 FLOW WARNING	P50	
A9	SIP200C TURBO PUMP NORMAL	N13		B9	STP200C TURBO PUMP NORMAL	N43		C9	SIP200C TURBO PUMP NORMAL	P25	
A10	SIP200C TURBO PUMP NORMAL	N49		B10	STP200C TURBO PUMP NORMAL	N50		C10	SIP200C TURBO PUMP NORMAL	P50	
A11	PV40EK SAFETY VALVE OPEN	N15		B11	PV40PK SAFETY VALVE OPEN	N45		C11	PV40EK SAFETY VALVE OPEN	P27	
A12	PV40EK SAFETY VALVE OPEN	N49		B12	PV40PK SAFETY VALVE OPEN	N50		C12	PV40EK SAFETY VALVE OPEN	P50	
A13	PV40EK SAFETY VALVE CLOSED	N19		B13	PV40PK SAFETY VALVE CLOSED	P1		C13	PV40EK SAFETY VALVE CLOSED	P31	
A14	PV40EK SAFETY VALVE CLOSED	N49		B14	PV40PK SAFETY VALVE CLOSED	P49		C14	PV40EK SAFETY VALVE CLOSED	P50	
A15	COLD CATHODE GUAGE 0-10 VDC	I1		B15	COLD CATHODE GUAGE 0-10 VDC	N7		C15	COLD CATHODE GUAGE 0-10 VDC	I13	
A16	COLD CATHODE GUAGE 0-10 VDC	I2		B16	COLD CATHODE GUAGE 0-10 VDC	N8		C16	COLD CATHODE GUAGE 0-10 VDC	I14	
A17	PIRANI GUAGE 0-10 VDC A1	I3		B17	PIRANI GUAGE 0-10 VDC A1	N9		C17	PIRANI GUAGE 0-10 VDC A1	I15	
A18	PIRANI GUAGE 0-10 VDC A1	I4		B18	PIRANI GUAGE 0-10 VDC A1	N10		C18	PIRANI GUAGE 0-10 VDC A1	I16	
A19	GUAGE 0-10 VDC A2	I5		B19	GUAGE 0-10 VDC A2	N11		C19	GUAGE 0-10 VDC A2	I17	
A20	GUAGE 0-10 VDC A2	I6		B20	GUAGE 0-10 VDC A2	N12		C20	GUAGE 0-10 VDC A2	I18	
A21	ID#1	N21		B21	ID#1	P3		C21	ID#1	P33	
A22	ID#2	N25		B22	ID#2	P7		C22	ID#2	P37	
A23	ID#3	N27		B23	ID#3	P9		C23	ID#3	P39	
A24	ID#4	N49		B24	ID#4	P49		C24	ID#4	P50	
A25	N/C			B25	N/C			C25	N/C		

INDEX OTHER SHEETS INDICATED BY NUMBER TO DRAWING FUNCTIONAL ASSEMBLY & SHOP THIS PLACE RECORD THIS PLACE RECORD PROTECT SURFACE AND BEAR CAREFULLY TO REMOVE ALL TAPS		CURRENT REVISION APPROVAL DRAWN: TONY T. GROUP: CBS SIGNATURE: DATE: 09-24-96		LIGO CALIFORNIA INSTITUTE OF TECHNOLOGY MASSACHUSETTS INSTITUTE OF TECHNOLOGY VCMS ELECTRICAL DRAWING PUMP CART CABLE / VME INTERFACE WIRING	
NO MIT SCALE THIS DRAWING USED ON: REFERENCE DRAWINGS	REV: DESCRIPTION SHEETS EFFECTED: DATE:	SCALE: 1:1 SIZE: 11x17 SHEET: 2 OF 2	D961399-00-C 00 1		

1399S1C0
 10-22-96 - 07:51

PSI | CDS

CDS | PSI

10' Pumpout Port Valve

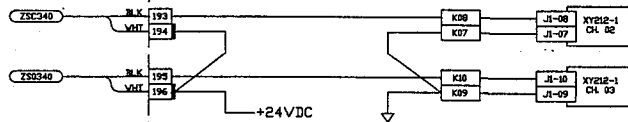

Turbo Pump Cart Monitoring

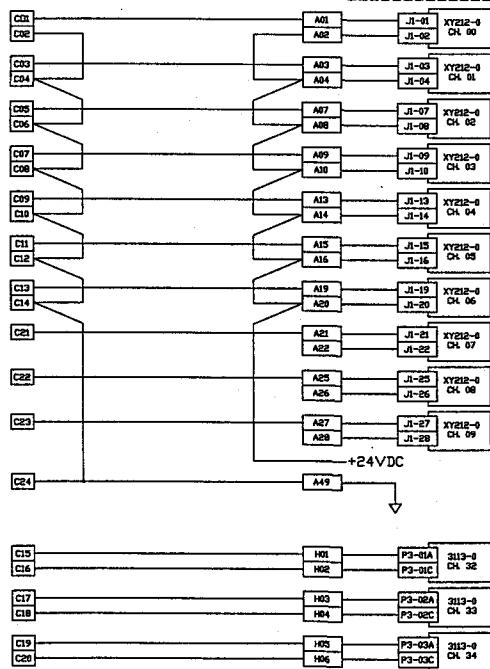

UNLESS OTHERWISE SPECIFIED				CURRENT REVISION APPROVAL				LIGO CALIFORNIA INSTITUTE OF TECHNOLOGY MASSACHUSETTS INSTITUTE OF TECHNOLOGY	
DIMENSIONS ARE IN INCHES FRACTIONS & DECIMALS ARE TO BE A TWO PLACE DECIMAL, A THREE PLACE DECIMAL, A FOUR PLACE DECIMAL OR MORE, UNLESS SHOWN OTHERWISE IN OUR DRAWING ALL DIMS				DRAWN	GROUP	SIGNATURE	DATE	VCMS ELECTRICAL DIAGRAM WA RIGHT MID STATION WCPS	
DO NOT SCALE THIS DRAWING				7	CDS		9-9-96	SCALE	SIZE/SCALE NO.
DWG. NO.	DESCRIPTION	DWG. NO.	DESCRIPTION	REV.	DESCRIPTION	SHEETS EFFECTED	DATE	CAD FILE	REV.
REFERENCE DRAWINGS				ISSUE DESCRIPTION				2 OF 2	
NEXT ASS'Y								D961337-00-C	
6		5		4		2			00
									00

13395200
10-17-96 - 11:47

PSI CDS

CDS PSI

WGV-15 Control

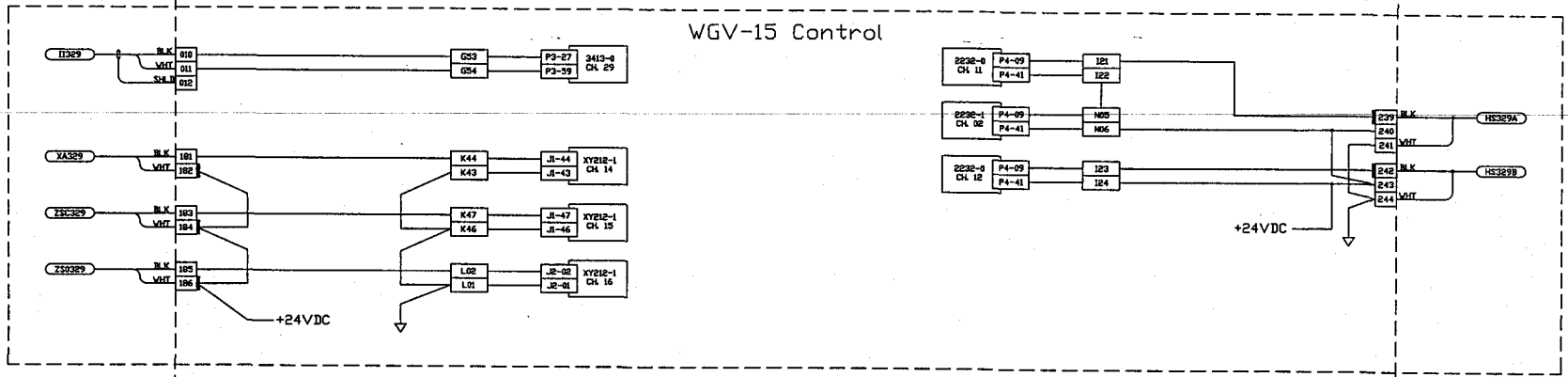

WGV-16 Control

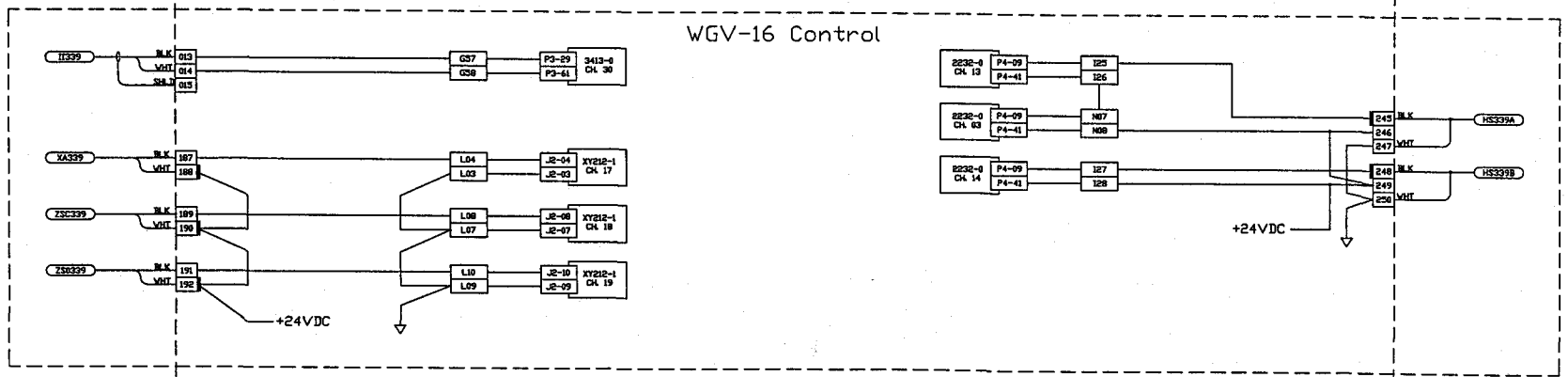

UNLESS OTHERWISE SPECIFIED				CURRENT REVISION APPROVAL				LIGO CALIFORNIA INSTITUTE OF TECHNOLOGY MANUFACTURES INSTITUTE OF TECHNOLOGY			
DIMENSIONS ARE IN INCHES TOLERANCES: FRACTIONS: ± .005 DECIMALS: ± .001 HOLE PLACES: ± .005 TAP PLACES: ± .005 SURFACE FINISH: AS SHOWN REMOVE ALL BARS				DATE	GROUP	DESIGN	SIGNATURE	DATE	VCMS ELECTRICAL DIAGRAM WA RIGHT MID STATION GATE VALVE CONTROL		
DWG. NO.	DESCRIPTION	DWG. NO.	DESCRIPTION	REV	DATE	ISSUE DESCRIPTION	SHEETS EFFECTED	DATE	SCALE	DRAWING NO.	REV
6	REFERENCE DRAWINGS	5		4						B	D961344-00-C
											00
											01
											02

1344S2C0
10-17-86 11:59

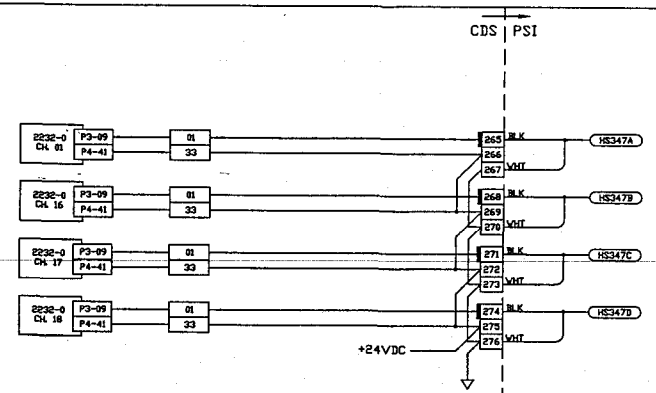
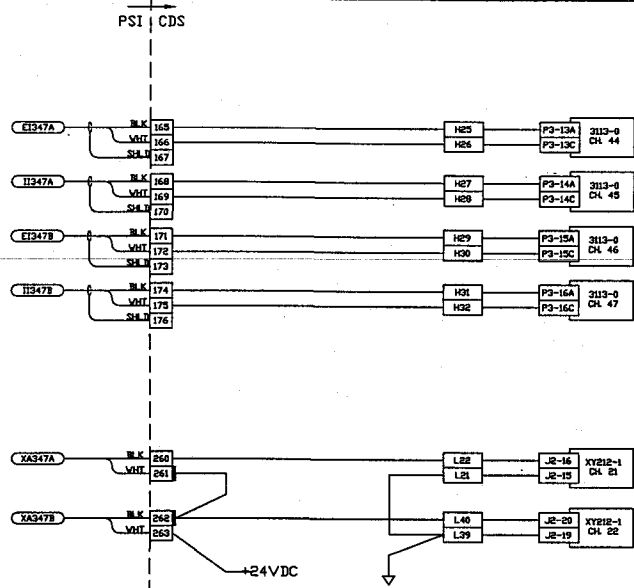

				UNLESS OTHERWISE SPECIFIED DIMENSIONS ARE IN INCHES TOLERANCES FRACTIONAL & DECIMAL DECIMALS & DIMS 1/16 PLACE DECIMALS 1/32 PLACE DECIMALS 1/64 PLACE DECIMALS UNLESS OTHERWISE SPECIFIED DIMENSIONS ARE IN INCHES		CURRENT REVISION APPROVAL DRAWN: _____ DATE: 9-9-76 CHECKED: _____ DESIGNED: _____ APPROVED: _____		UIC CALIFORNIA INSTITUTE OF TECHNOLOGY MORGANVILLE INSTITUTE OF TECHNOLOGY VCMS ELECTRICAL DIAGRAM WA RIGHT MID STATION WA ION PUMP - 10		
DWG. NO. 6	DESCRIPTION REFERENCE DRAWINGS	DWG. NO. 5	DESCRIPTION NEXT ASSY:	REV. 4	DESCRIPTION ISSUE DESCRIPTION	SHEETS EFFECTED 2	DATE	SCALE 1" = 1"	DRAWING NO. B D961345-00-C SHEET 1 OF 1	REV. P1 DATE

134551C0
10-28-96 - 07:55

APPENDIX B: EXAMPLE OPERATOR DISPLAY PANELS

1. VCMS Overview Panel
2. Hanford Vertex Section
3. Hanford Diagonal Section
4. Hanford Right Midstation
5. Hanford Right End Station
6. Isolation Valve Detail
7. 80K Pump Overview
8. 80K Pump Detail
9. Pumpout Port
10. Trend Plot
11. VCMS Diagnostics

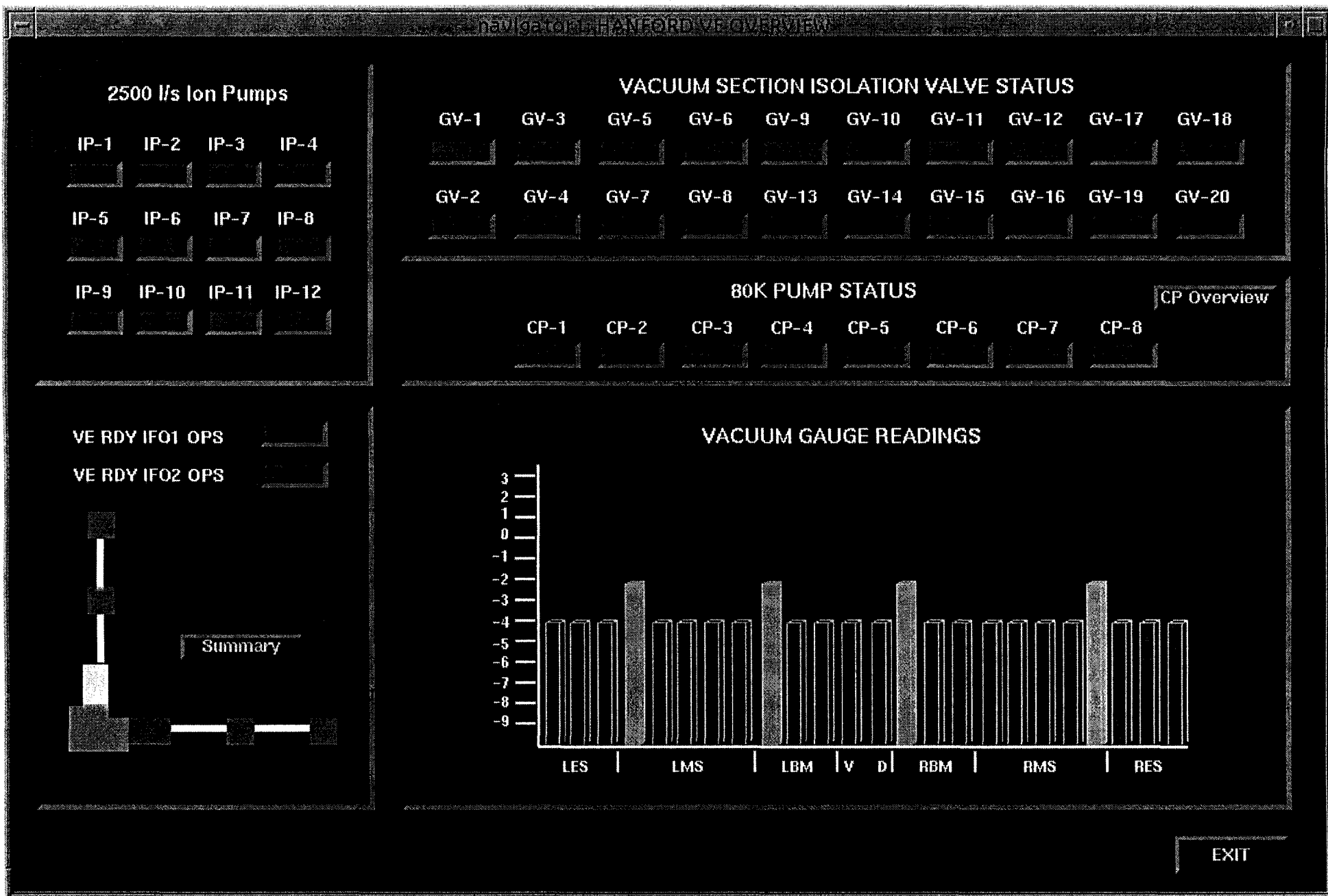

Figure 1: VCMS Overview Display

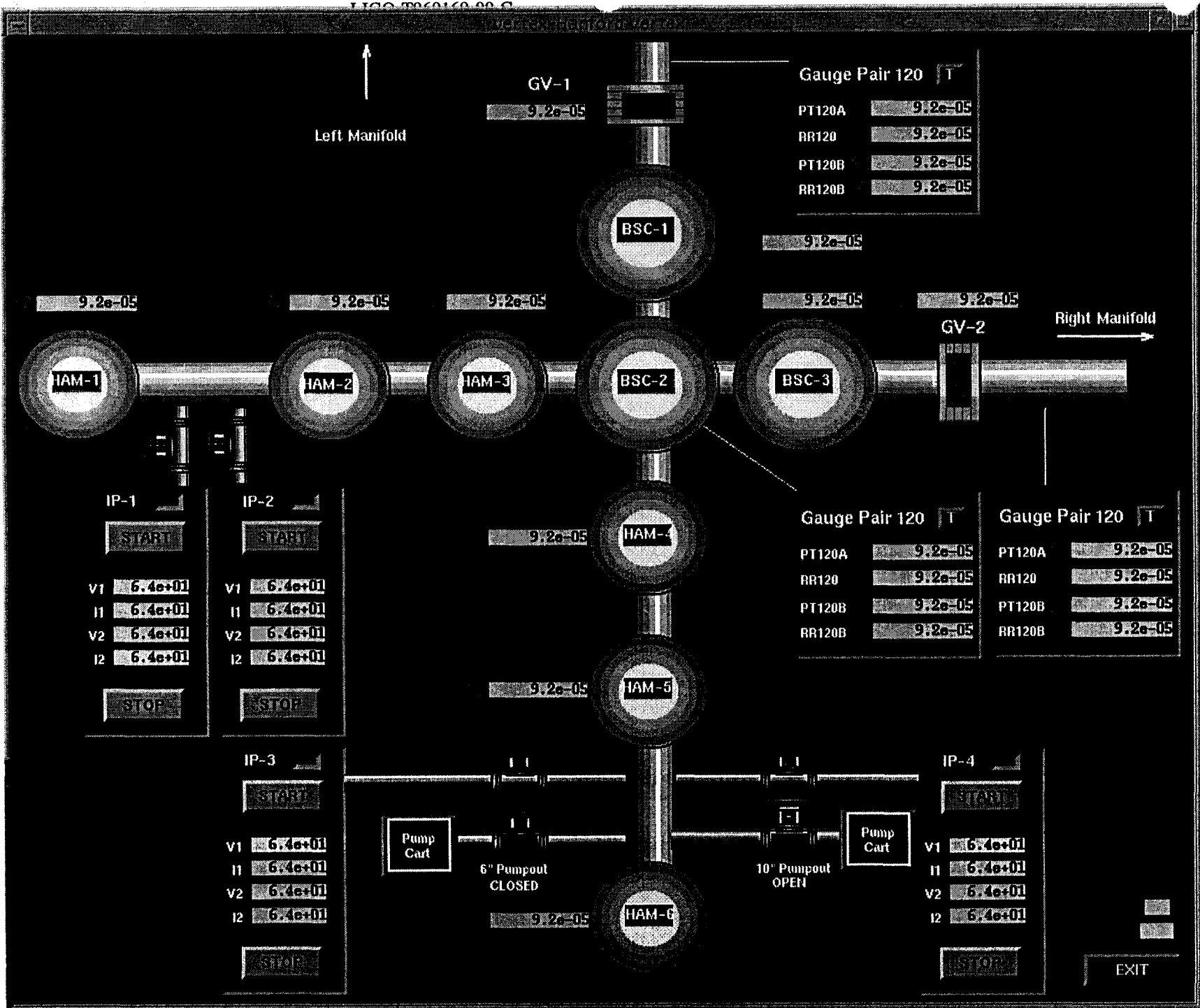

Figure 2: Hanford Vertex Section Display

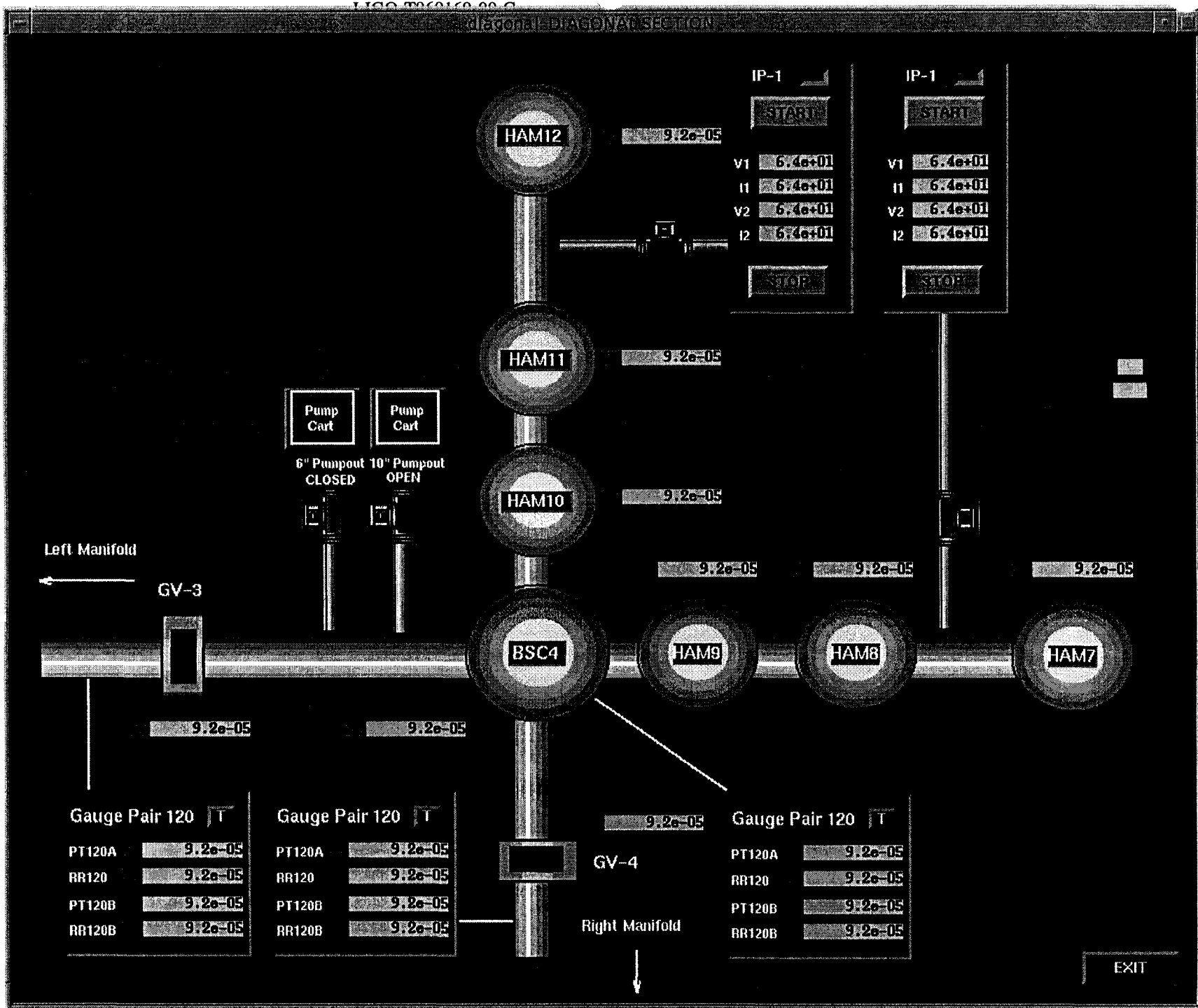

Figure 3: Hanford Diagonal Section Display

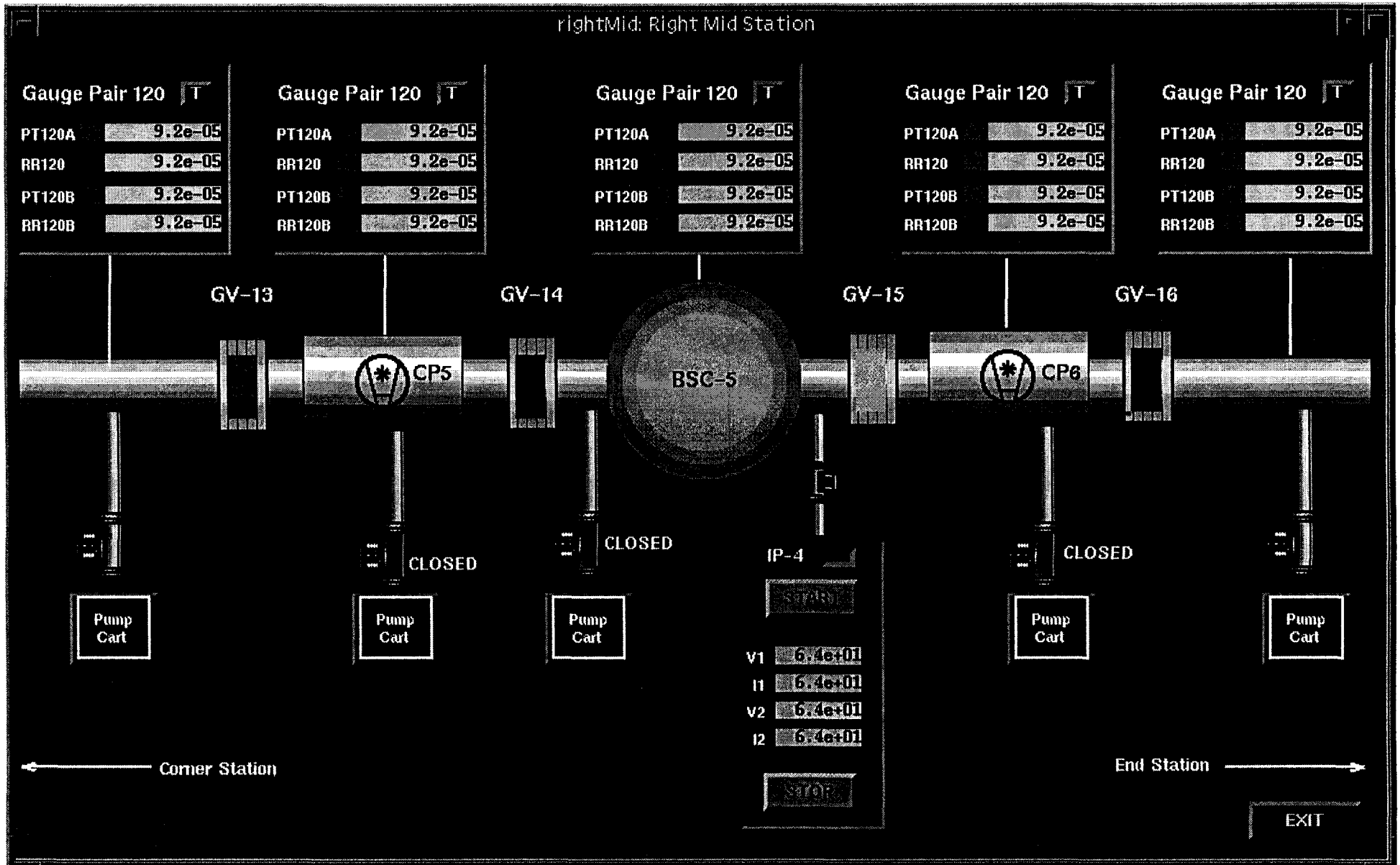

Figure 4: Hanford Right Midstation Display

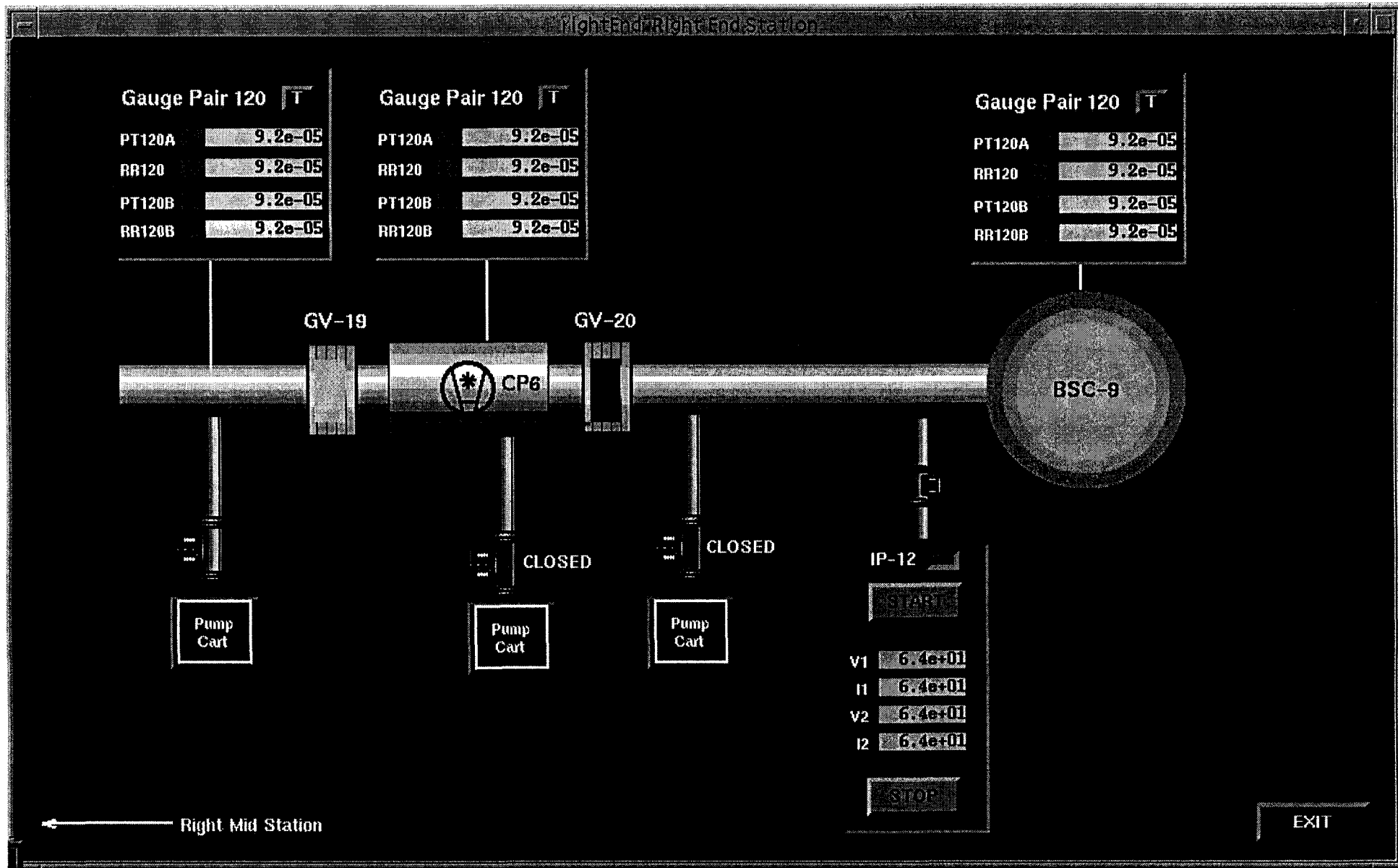

Figure 5: Hanford Right End Station Display

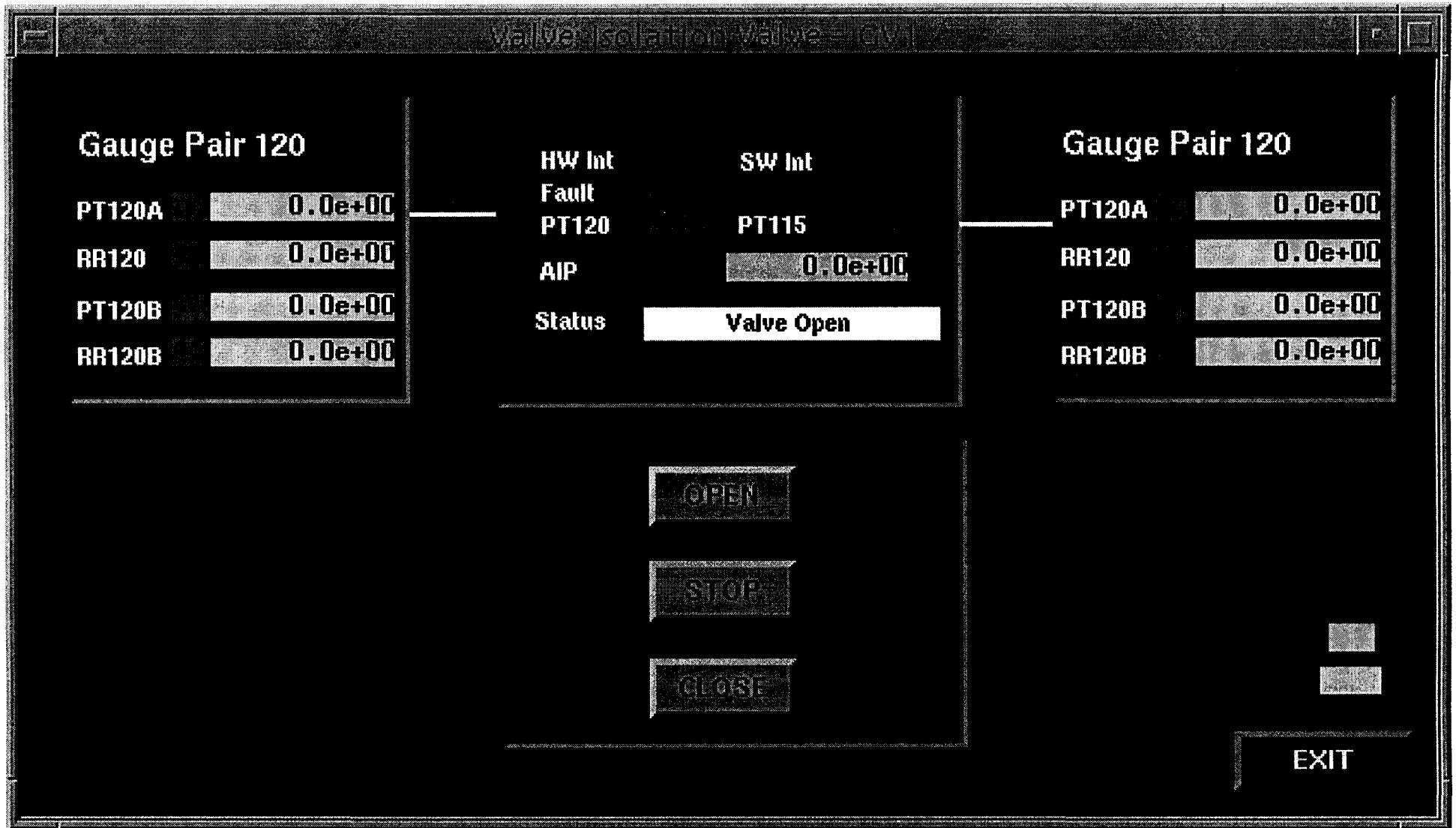

Figure 6: Isolation Valve Detail Display

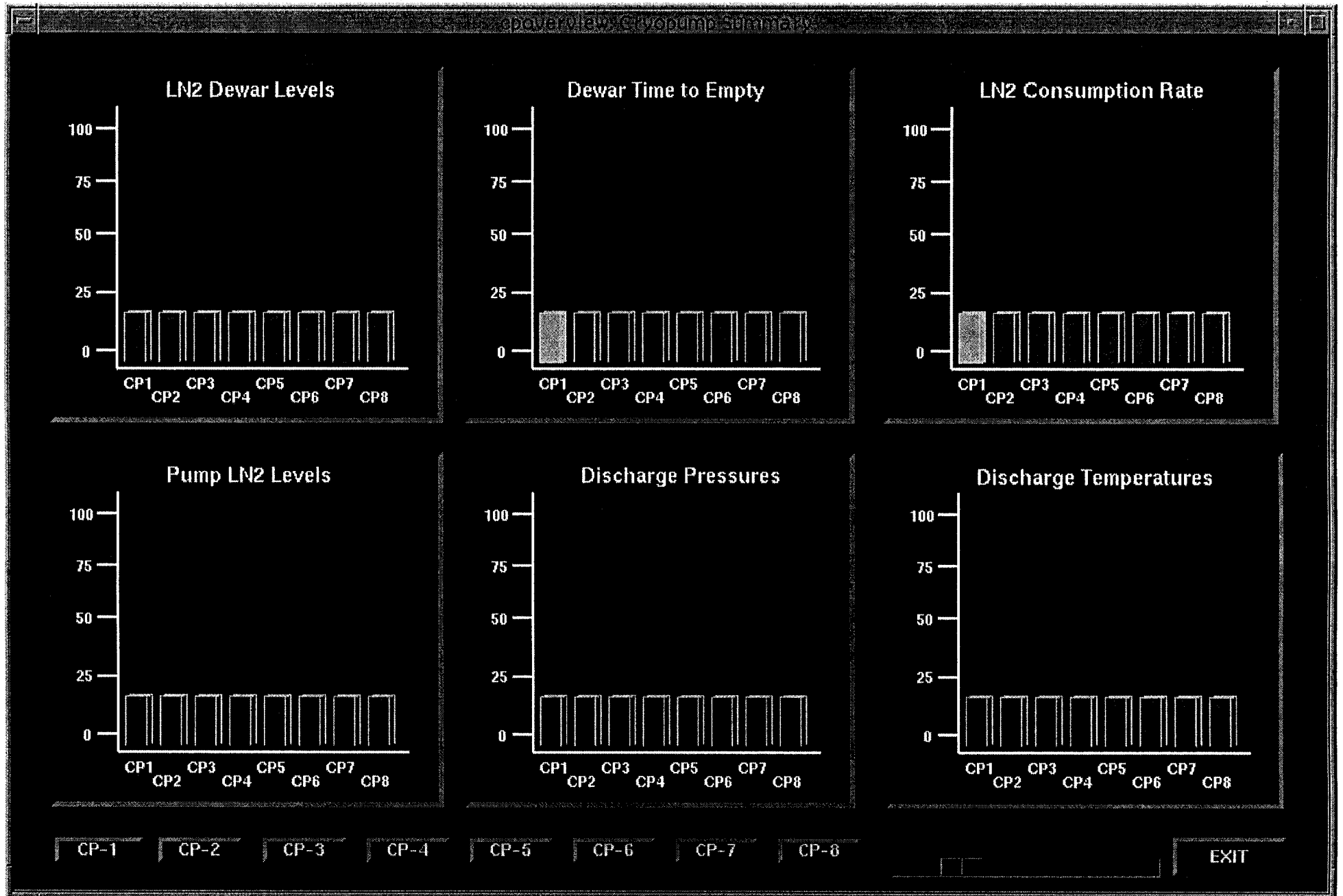

Figure 7: Hanford 80K Pump Overview Display

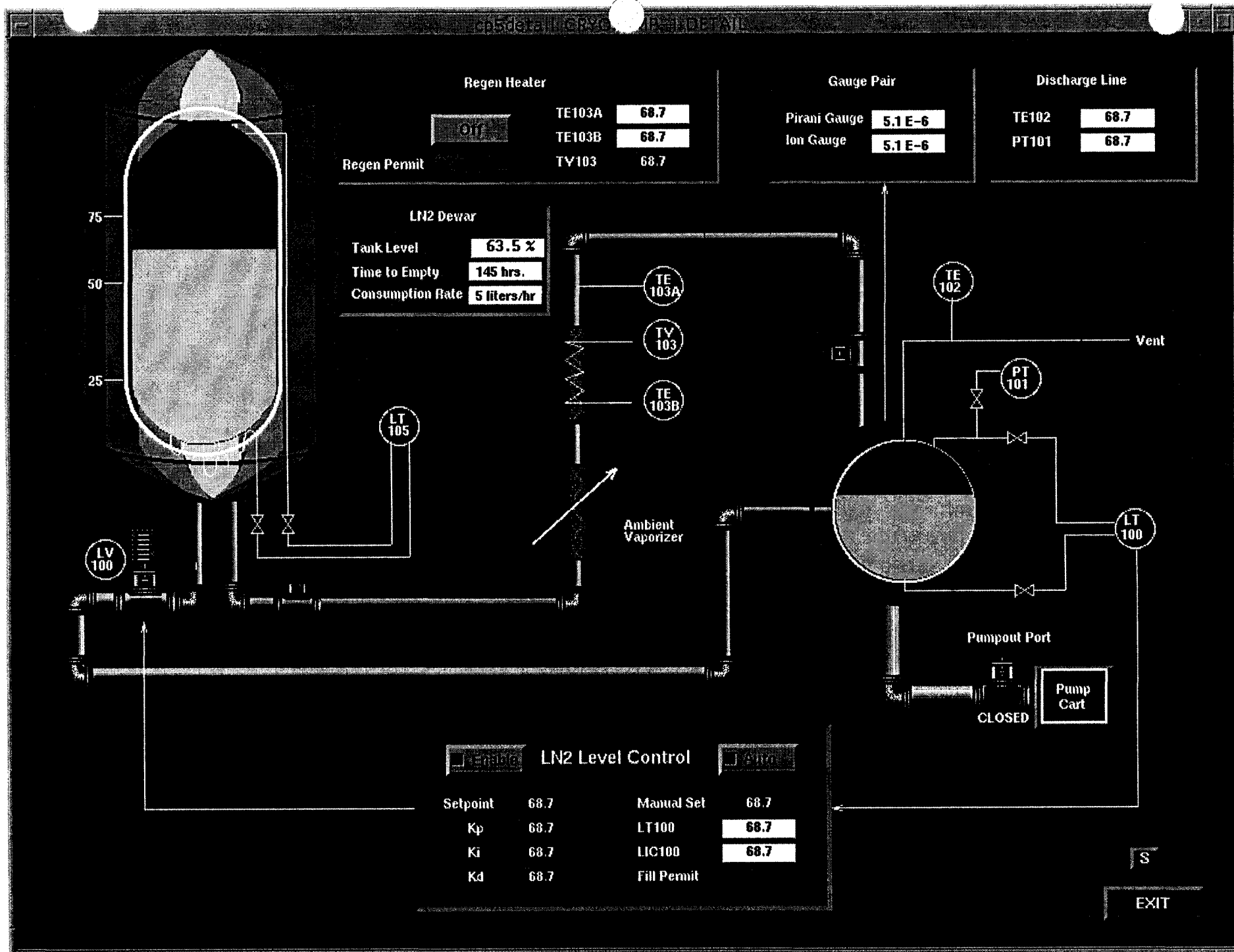

Figure 8: 80K Pump Detail Display

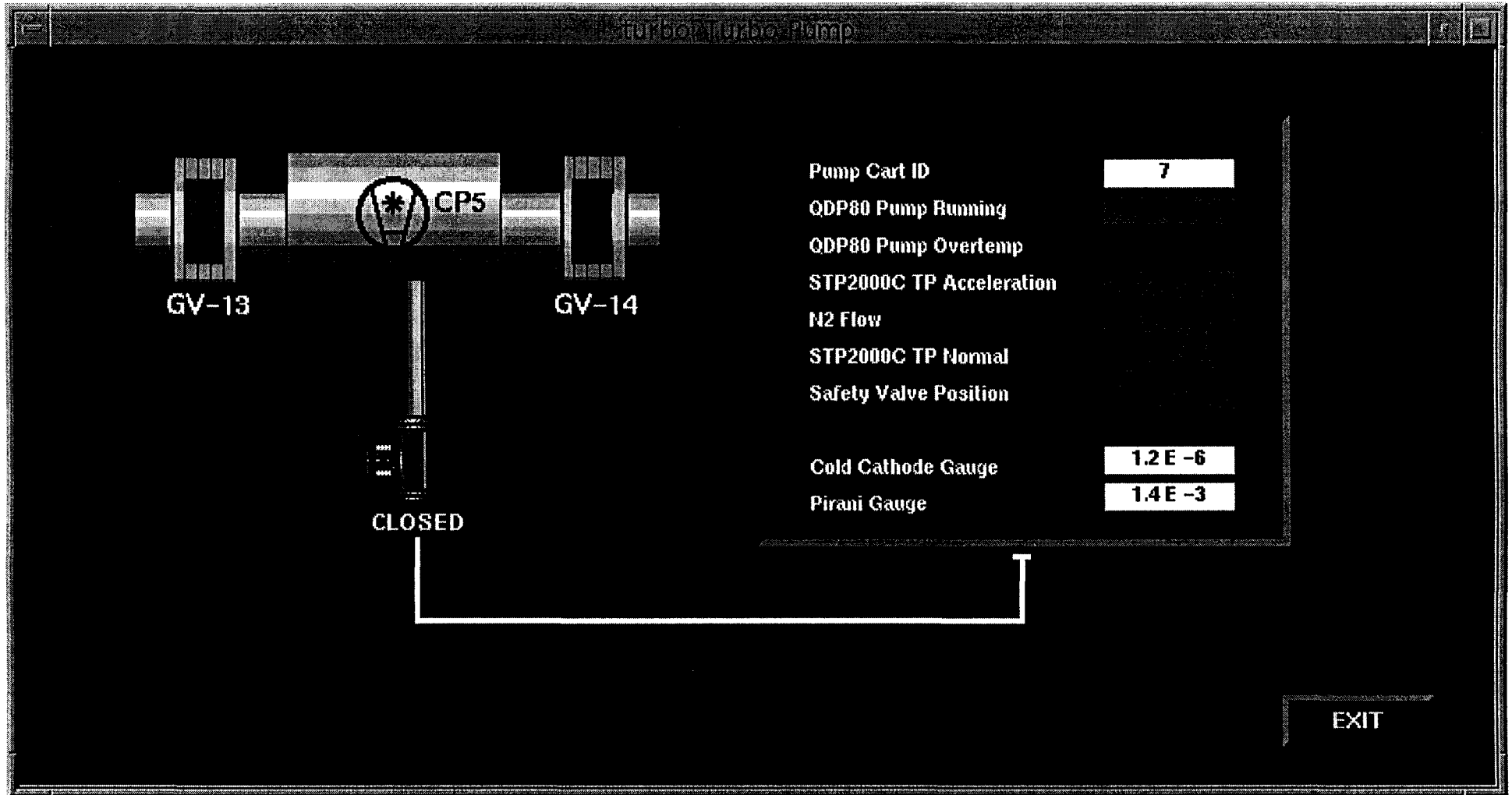

Figure 9: Pump Port Display

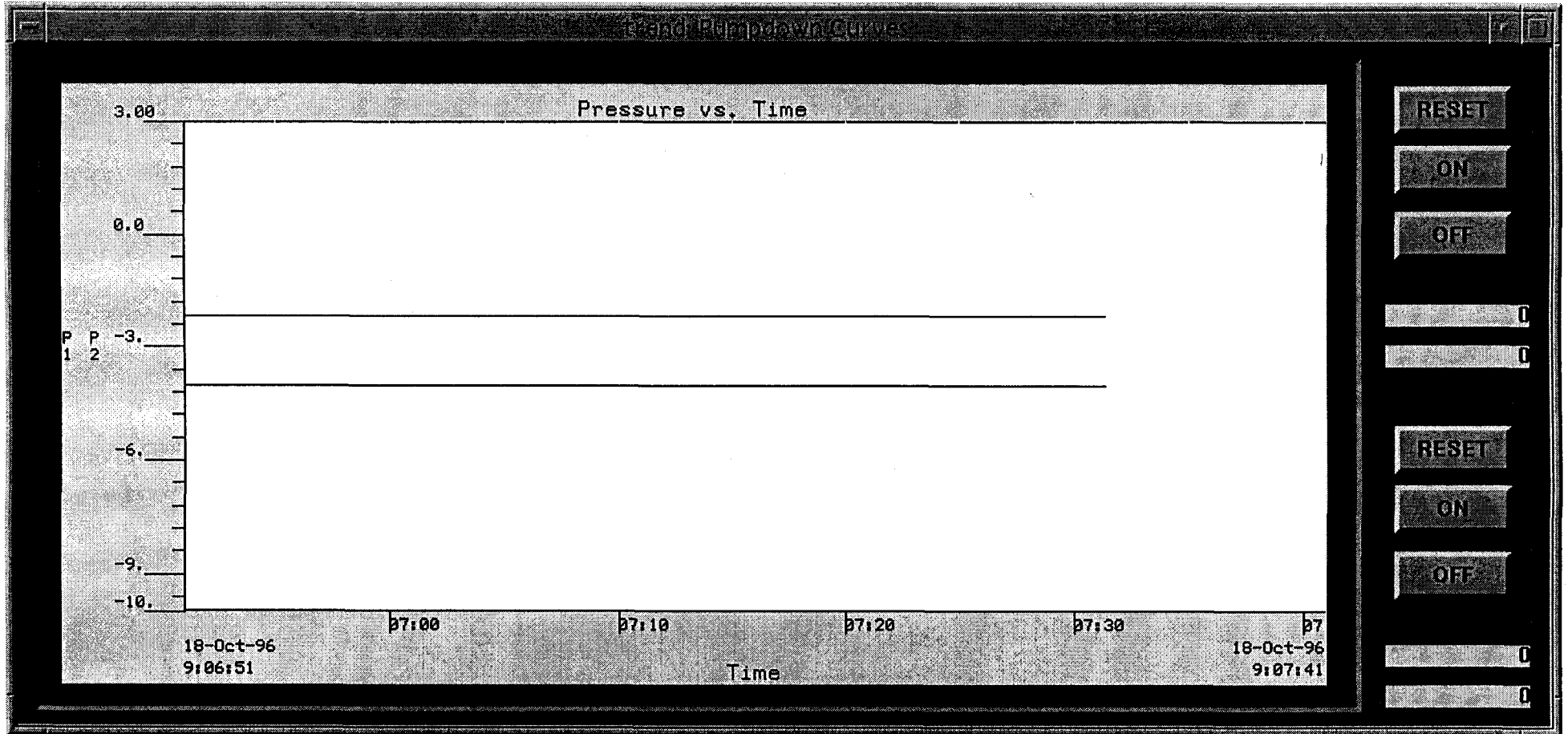

Figure 10: Example Trending Display

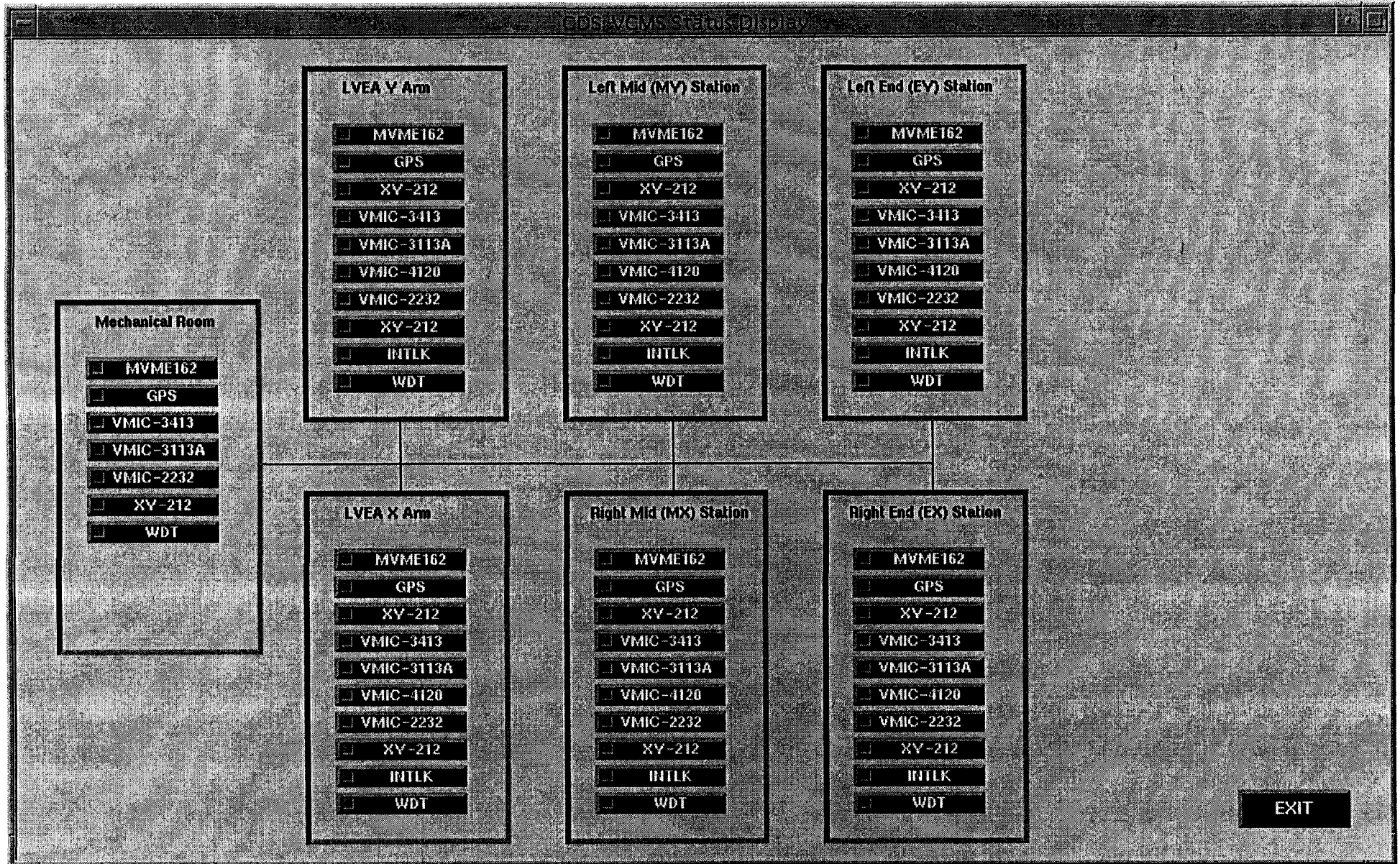
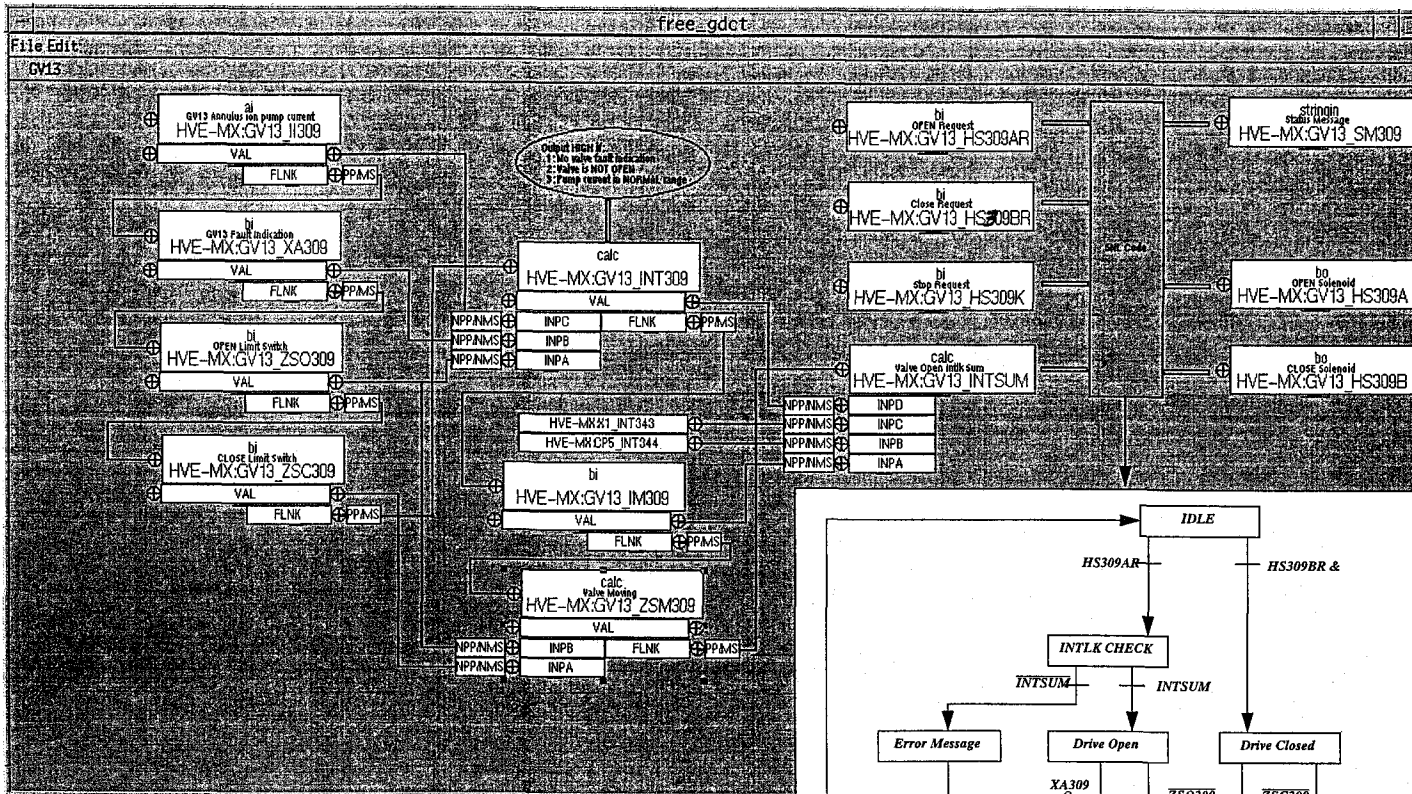

Figure 11: Hanford VCMS Diagnostics Display

APPENDIX C: SOFTWARE DIAGRAMS

This appendix contains representative EPICS software diagrams of Hanford right midstation assemblies.

1. WGV-13 Control Software
2. WCP-5 Level Control
3. WCP-5 Regeneration Control
4. MX Beam Tube gauges
5. WBSC-5
6. WCP-5 Pumpout Port and Turbo Cart Monitoring
7. Pump Cart Hours Monitoring
8. WIP-5 2500 l/s Ion Pump



Purpose: Monitor and control WGV-13; verify interlocks prior to allowing valve to be opened.

Operational Description:

Software composed of EPICS records and an SNL program.

1. EPICS records continuously monitor valve position, fault indication, and annulus ion pump current. INT records check if state proper to allow opening of the valve, with INTSUM set TRUE when all conditions to open are met: ion pump current normal, valve not already open, no fault indication, VME interlock module signal TRUE, PT343 and PT344 < 1x10⁻⁴.
2. SNL code sits in IDLE until operator request valve to open. It then drops to INTLK CHECK and verifies INTSUM is TRUE. If not, error message is sent via SM309.
3. If INTSUM, then SNL goes to Drive Open state, which sets HS309A true and energizes the drive open relay. This continues until the Open limit switch is reached or operator requests the valve to stop (HS309K).
4. When Open Limit is detected, SNL goes to delay state. This is a one second delay to ensure valve seats Open. Code then goes to Stop Drive state, which resets HS309A low, deenergizing the drive open relay. Program returns to IDLE to await next request.
5. If Close command set (HS309BR), SNL first checks no valve fault exists (XA309), then goes to Drive Closed state. Here HS309B is set high, energizing the drive closed relay. SNL stays in this state until Closed limit switch is detected or operator requests valve to stop (HS309K).
6. Once close limit detected, SNL again goes into delay and stop states, same as for valve open operation. In this case, HS309B is set low in the stop state.

Table 1: Data Dictionary

Signal	Description
I1309	GV13 Annulus Ion Pump Current
XA309	GV13 Fault Indication
ZSO309	Valve Open Indication
ZSC309	Valve Closed Indication
INT309	GV13 Open Intlk: Checks valve OPEN, FAULT, and I1309 in normal range
INT343	Interlock from gauge pair PT343A/B
INT344	Interlock from gauge pair PT344A/B
ZSM309	Valve Moving Indicator (Off open and closed seats)
HS309AR	Valve Open Request
HS309BR	Valve Close Request
HS309K	Valve Stop Request
INTSUM	Valve Open Permit; TRUE if INT309, INT343 and INT344 TRUE.
SM309	Status Info String to operator
HS309A	Output signal to valve open solenoid
HS309B	Output signal to valve close solenoid
IM309	VME interlock module

Figure 1 : WGV-13 Control Software

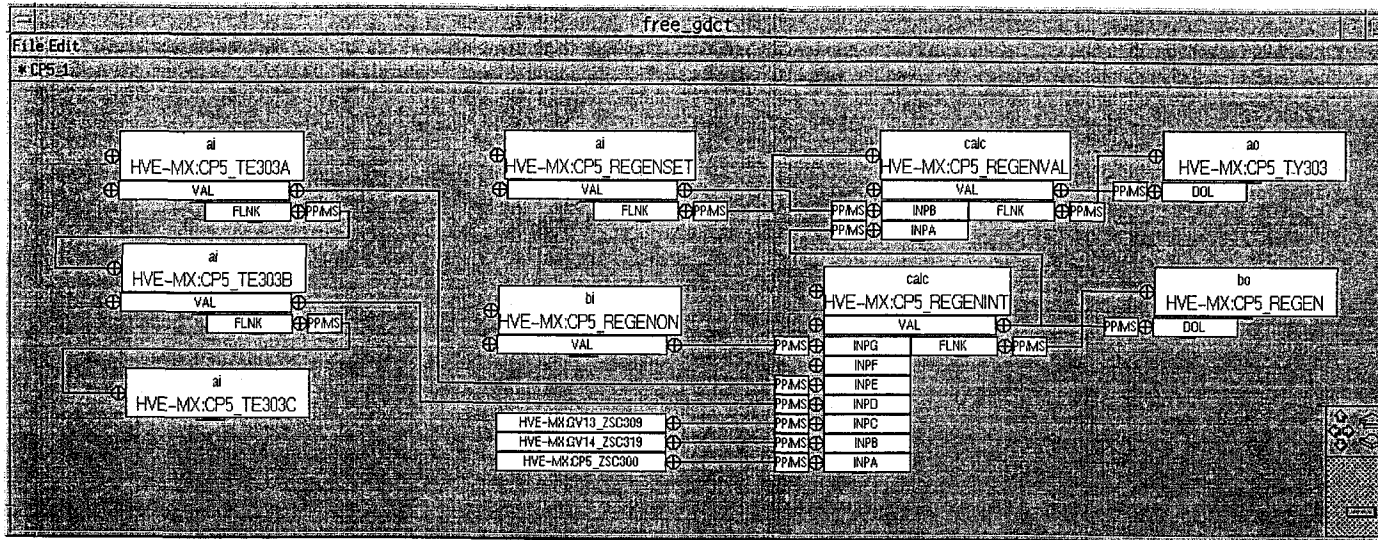

Table 1: Data Dictionary

Signal	Description
TE303A	Regen Heater Thermocouple
TE303B	Regen Heater Element Thermocouple
TE303C	Regen Loop Thermocouple (Spare)
REGENSET	Regen Temperature setpoint
REGENON	Heater ON Request
REGENINT	Regen Heater Interlock
REGENVAL	Heater temperature setting
TY303	Output to regen heater
REGEN	Heater ON/OFF output
ZSC309	GV13 Closed Contact
ZSC319	GV14 Closed Contact
ZSC300	CP5 fill control valve CLOSED

Purpose: Monitor and control the regeneration heater for WCP-5.

Operational Description:

Regeneration of cryopumps is mostly a manual operation, as described in LIGO E960127-00-V.

1. The operator selects a regen heater temperature setpoint via REGENSET and enables the heater via REGENON.
2. When REGENON is TRUE, REGENINT verifies that the system is in a state to allow regeneration. This check is 1) Loop temperatures below high alarm limits (TE303A/B), AND 2) vacuum section isolation valves either side of the cryopump are closed, AND 3) LN2 flow control valve from Dewar (LV300) is closed.
3. If the output of REGENINT is TRUE, then the heater setpoint value (REGENSET) is allowed to pass thru REGENVAL to TY303, the 4-20mA output to the heater. REGEN is also set TRUE, enabling a relay which is in series with the TY303 signal. (Note: The output to TY303 is not a closed loop control.)
4. REGENINT continuously checks that the system remains in a proper state for regen. If not, such as temperatures go above alarm limits, REGENINT will turn off the regen heater until system parameters are again in a normal range for regen.

Figure 3 : WCP5 Regen Control

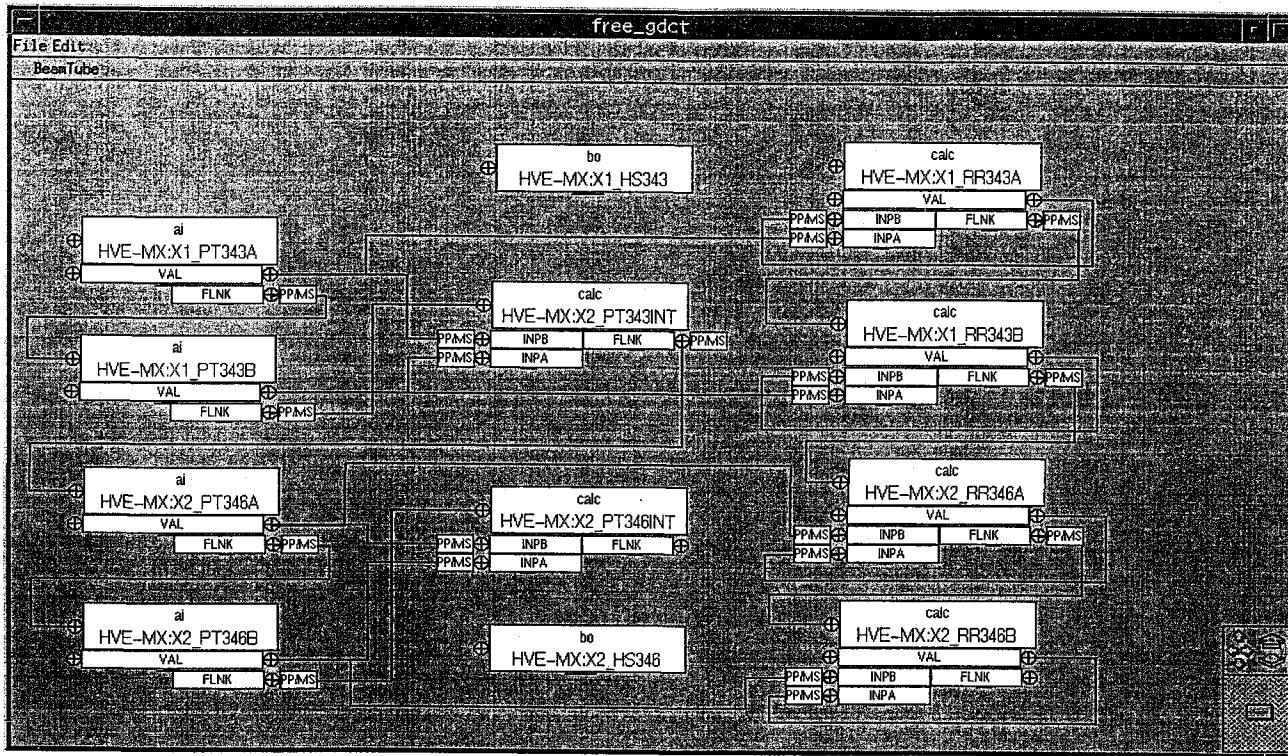

Table 1: Data Dictionary

Signal	Description
X1_PT343A	Beam Tube X1 Pirani Gauge
X1_PT343B	Beam Tube X1 Cold Cathode Gauge
X2_PT346A	Beam Tube X2 Pirani Gauge
X2_PT346B	Beam Tube X2 Cold Cathode Gauge
PT343INT	Isolation Valve Opening Interlock
PT346INT	Isolation Valve Opening Interlock
HS343	Cold Cathode Gauge ON command
HS346	Cold Cathode Gauge ON command
RR343A	Pirani Gauge Rate of Rise Calculation
RR343B	Cold Cathode Gauge Rate of Rise
RR346A	Pirani Gauge Rate of Rise Calculation
RR346B	Cold Cathode Gauge Rate of Rise

Purpose: Monitor the signals associated with beam tube gauge pairs at the Hanford right midstation; provide vacuum interlock signals for isolation gate valves.

Operational Description:

1. PT343A is set to 1 sec. scan, and causing remaining chain of EPICS records to be processed. PT343A, PT343B, PT346A and PT346B read the values from the gauges and convert them to Torr.
2. PT343INT and PT346INT use the gauge pair inputs to determine if vacuum is <math><10^{-4}</math>; Output is used by gate valve interlock chain.
3. HS343 and HS344 accept operator commands to turn on/off the cold cathode gauges.
4. RR343A/B and RR346A/B calculate the rate of rise of the gauge readings. These records process every 5 seconds.

Figure 4 : MX Beam Tube Gauges

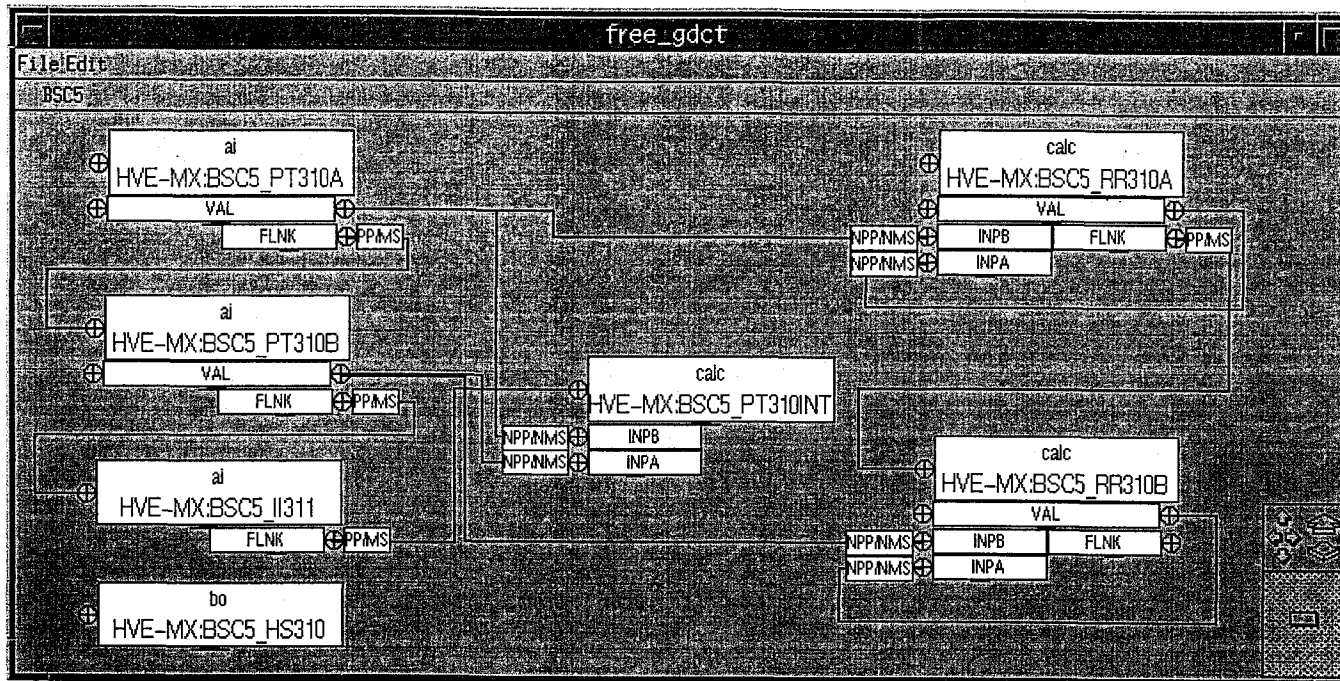

Table 1: Data Dictionary

Signal	Description
PT310A	Pirani Gauge Reading
PT310B	Cold Cathode Gauge Reading
II311	Annulus Ion Pump Current Reading
PT310INT	Isolation Valve Opening Interlock
HS310	Cold Cathode Gauge ON command
RR310A	Pirani Rate of Rise
RR310B	Cold Cathode Gauge Rate of Rise

Purpose: Monitor the signals associated with WBSC-5.

Operational Description:

1. PT343A is set to 1 sec. scan, and causing remaining chain of EPICS records to be processed. PT343A, PT343B and II310 read the values from the gauges and convert them to Torr.
2. PT343INT uses the gauge pair inputs to determine if vacuum is $<10^{-4}$; Output is used by gate valve interlock chain.
3. HS343 accepts operator commands to turn on/off the cold cathode gauges.
4. RR310A/B calculate the rate of rise of the gauge readings. These records process every 5 seconds.

Figure 5 : BSC-5 Software

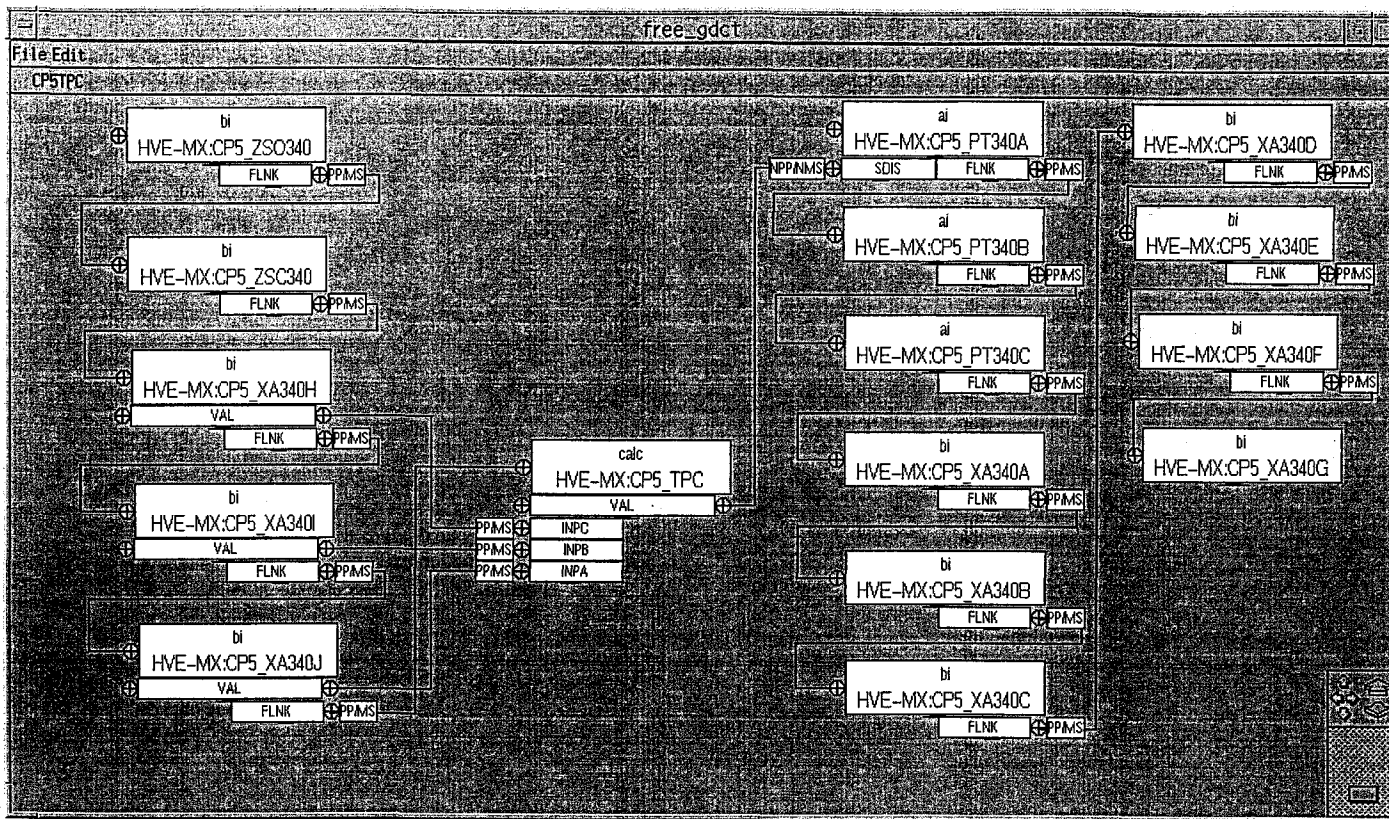

Table 1: Data Dictionary

Signal	Description
ZSC340	Port Isolation Valve CLOSED contact
ZSO340	Port Isolation Valve OPEN contact
XA340H	Pump Cart ID bit 0
XA340I	Pump Cart ID bit 1
XA340J	Pump Cart ID bit 2
TPC	Pump Cart ID (Calc from 340H thru J)
PT340A	Cold Cathode Gauge Reading
PT340B	Pirani Gauge Reading
PT340C	Gauge A2 Reading
XA340A	Backing Pump Running Contact
XA340B	Backing Pump Temperature Hazard
XA340C	Turbo Pump Acceleration Contact
XA340D	N2 Flow Warning
XA340E	Turbo Pump Normal
XA340F	Safety Valve Open
XA340G	Safety Valve Closed

Purpose: Monitor the signals associated with the cryopump 10" pumpout port, including valve position and pump cart parameters.

Operational Description:

1. ZSO340 is set to 1 sec. scan, and causing remaining chain of EPICS records to be processed. ZSC340 and ZSO340 are the port isolation valve Closed/Open indicators. XA340H thru XA340J act as the pump identification tag.
2. CP5_TPC calculates the ID of the pump cart connected by evaluating the three inputs. This ID number shows up in the pump port display and is also used by an SNL program to identify where to log pump hours.
3. PT340A thru PT340C are pressure gauge readings from the pump cart. XA340A thru XA340G are various contact status indicators from the pump cart. These records are processed and updated at 1 second intervals if and only if the output value of CP5_TPC is > 0. This avoids processing when no pump cart is connected.

Figure 6: WCP-5 Pumpout Port

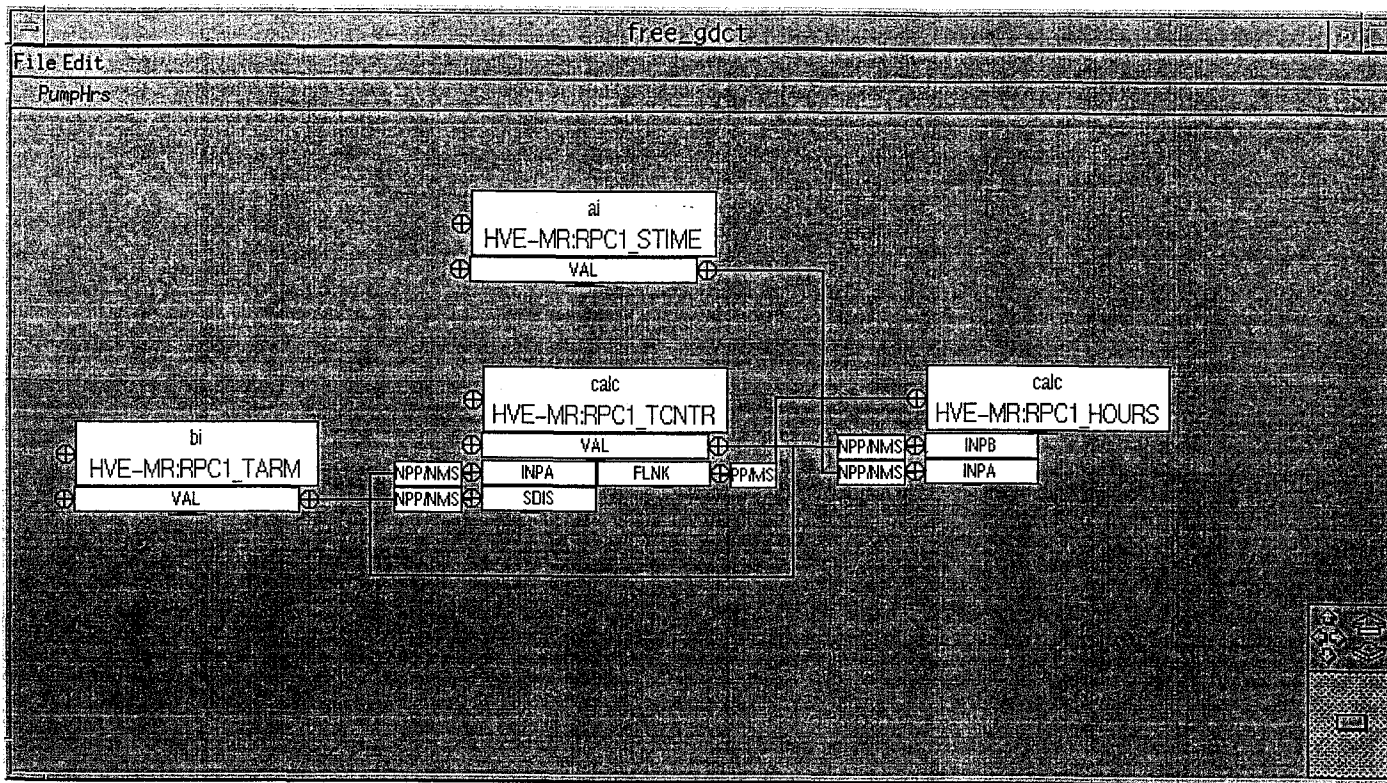

Table 1: Data Dictionary

Signal	Description
TARM	Set by SNL program whenever pump is ON; this allows TCNTR to process.
TCNTR	Processes every 10sec if TARM is TRUE. This record counts time that pump has run since last time VME crate was rebooted.
STIME	On VME reboot, this value is read from file, which is total pump hours.
HOURS	Calculates pump operating hours by adding hours from STIME and TCNTR.

Purpose: Calculate pump hours for a roughing pump cart. Software to calculate hours for a turbo pump cart would be similar.

Operational Description:

1. The records shown operate in conjunction with an SNL program (not shown). On VME processor power up or reboot, the SNL reads the previous pump hours from a file on the CDS server and writes that value to STIME.
2. Whenever a pump is started, this is detected by the SNL from pump port records (see Figure 6). The SNL reads the pump cart ID (from TPC of figure 6) and sets the appropriate TARM to TRUE.
3. When TARM is TRUE, TCNTR is allowed to process every 10 seconds. This is a running total of pump run time since the VME processor came on-line.
4. TCNTR then causes HOURS to process, which adds TCNTR and STIME. The output is the total pump operational hours, which shows up on designated operator display panels.
5. Every 10 minutes, the SNL program writes the value of HOURS to file, such that the pump hours are recorded and can be used to set STIME the next time the VME processor is rebooted (after a maintenance or other downtime).

Figure 7 : Pump Cart Hours

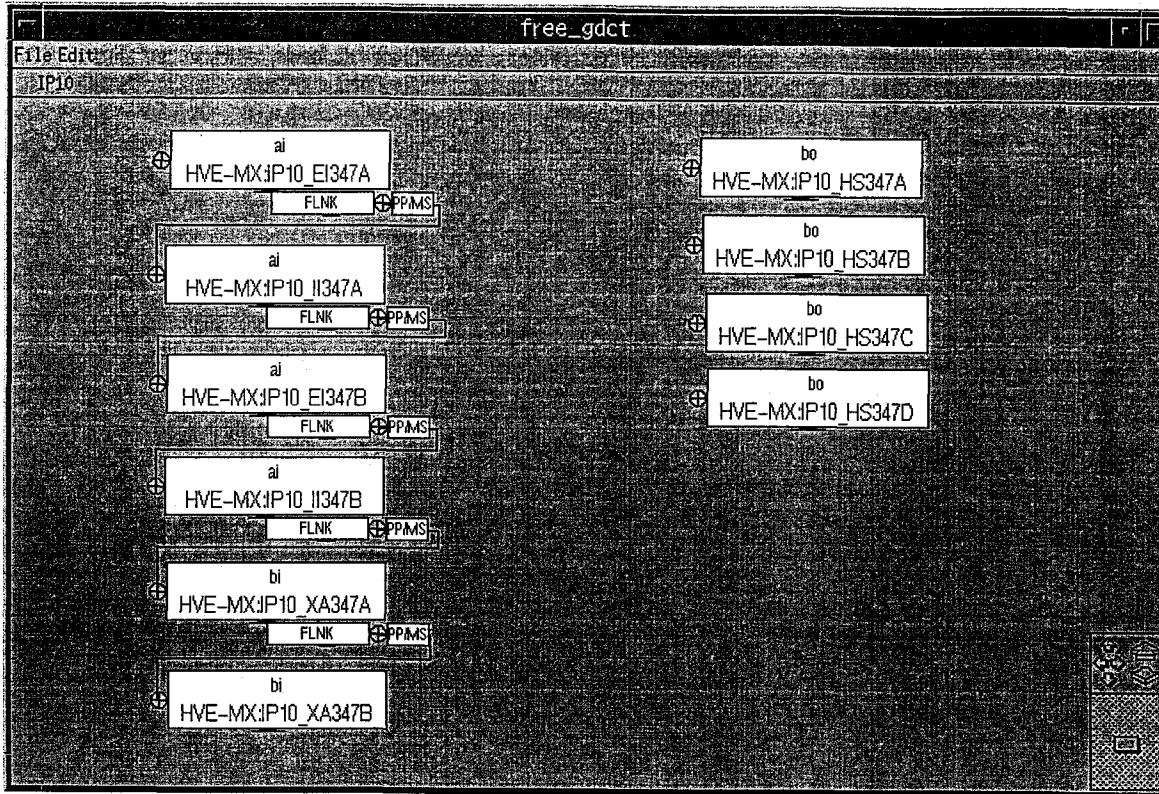

Table 1: Data Dictionary

Signal	Description
EI347A	Pump 1 Voltage Reading
II347A	Pump 1 Current Reading
EI347B	Pump 2 Voltage Reading
II347B	Pump 2 Current Reading
XA347A	Pump 1 Fault Indication
XA347B	Pump 2 Fault Indication
HS347A	Pump 1 Start
HS347B	Pump 1 Stop
HS347C	Pump 2 Start
HS347D	Pump 2 Stop

Purpose: Monitor and control WIP10, 2500 l/s ion pump.

Operational Description:

1. Records on left monitor pump voltages, currents and faults at one second intervals.
2. HS347A thru D are operator selections to turn on/off pump. These energize appropriate relays in a VME relay output module.

Figure 8 : 2500 l/s IP-10

**APPENDIX D: VACUUM SECTION ISOLATION VALVE
INTERLOCK MODULE DESIGN**

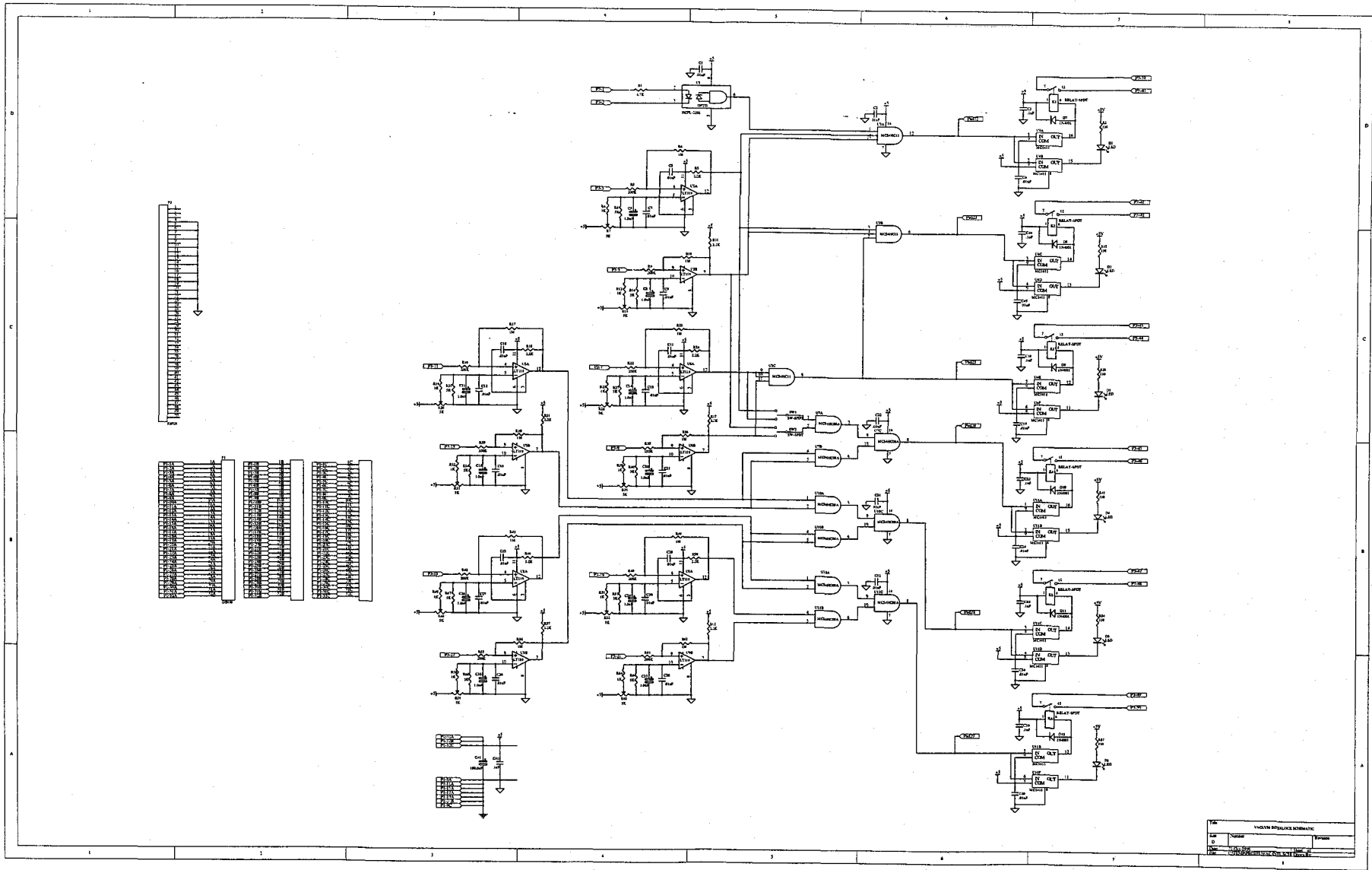

VACUUM TUBE SCHEMATIC

Rev	Number	Issue
1	1	1

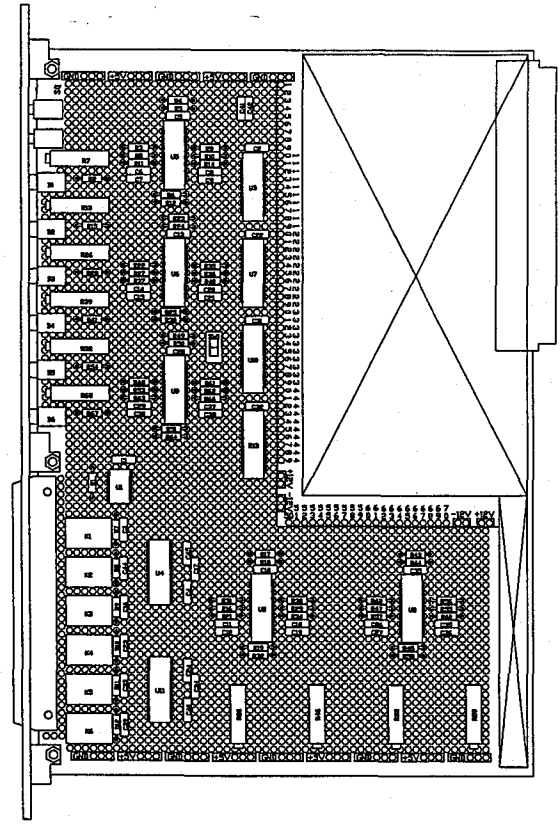
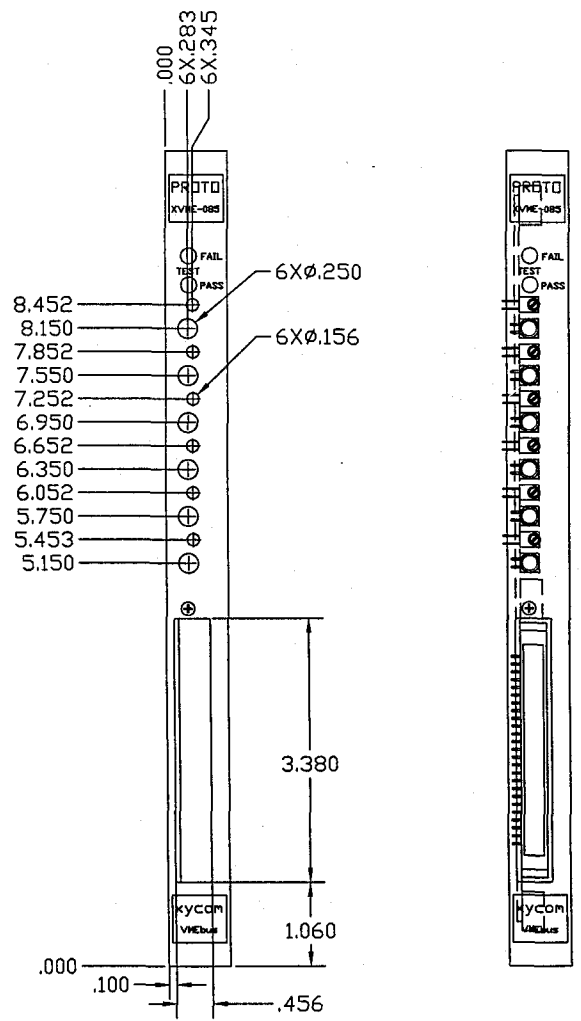

				UNLESS OTHERWISE SPECIFIED DIMENSIONS ARE IN INCHES TELEPHONE: (617) 253-8000 FAX: (617) 253-8001 WWW: WWW.LIGO.EDU LIGO: LIGO				CURRENT REVISION APPROVAL CHECKED: TONY T. DATE: 10-11-96 DESIGNED: CIS SIGNATURE:				LIGO CALIFORNIA INSTITUTE OF TECHNOLOGY MASSACHUSETTS INSTITUTE OF TECHNOLOGY	
				DO NOT SCALE THIS DRAWING USED ON: REV:				VACUUM INTERLOCK SCALE: - DRAWING NO: D VACINTLK SHEET: 1 OF 1					
6	5	4	3	2	1								
ING. NO.	DESCRIPTION	ING. NO.	DESCRIPTION	REV	DESCRIPTION	SHEETS	DATE	ISSUE	DESCRIPTION	SCALE	DRAWING NO.		
	REFERENCE DRAWINGS				ISSUE DESCRIPTION	1 OF 1					VACINTLK		

VACINTLK
10-11-96 - 12:53