

LASER INTERFEROMETER GRAVITATIONAL WAVE OBSERVATORY
- LIGO -
CALIFORNIA INSTITUTE OF TECHNOLOGY
MASSACHUSETTS INSTITUTE OF TECHNOLOGY

| | | | |
|--|-------------------|---|---------|
| Technical Note | LIGO-T960178-01 - | E | 12/9/96 |
| Beam Tube Bakeout Conceptual Design | | | |
| W. Young | | | |

Distribution of this draft:

This is an internal working note
of the LIGO Project.

California Institute of Technology
LIGO Project - MS 51-33
Pasadena CA 91125
Phone (818) 395-2129
Fax (818) 304-9834
E-mail: info@ligo.caltech.edu

Massachusetts Institute of Technology
LIGO Project - MS 20B-145
Cambridge, MA 01239
Phone (617) 253-4824
Fax (617) 253-7014
E-mail: info@ligo.mit.edu

WWW: <http://www.ligo.caltech.edu/>

1 INTRODUCTION

1.1. Purpose and Scope

The purpose of this document is to outline a conceptual design for the thermal insulation, heating power and control, pumping, instrumentation, and data acquisition and logging equipment to be used for the bakeout of the LIGO Beam Tube Modules. The conceptual design is used to illustrate a design approach which meets the requirements defined in the draft Beam Tube Bakeout Design Requirements Document (LIGO-E960123-01-E). During the preliminary design phase, analytical and trade-off studies will be performed to optimize the design approach. Once the design has been completed and approved, the equipment and processes developed will be used by the on-site LIGO staff to perform the bakeout.

1.2. Acronyms

| | |
|-----------------|---|
| AC | Alternating Current |
| AP | Blanked Port for Auxiliary Turbo Pump |
| BT | Beam Tube |
| BTE | Beam Tube Enclosure |
| CBI | Chicago Bridge and Iron, Inc. (Beam Tube fabrication and installation contractor) |
| CC | Cold Cathode Gauge |
| CH ₄ | Methane |
| CL | Blanked Port for Calibrated Leaks |
| CO | Carbon Monoxide |
| CO ₂ | Carbon Dioxide |
| DAS | Data Acquisition System |
| DC | Direct Current |
| DRD | Design Requirements Document |
| L | Variable Leak Valve |
| LIGO | Laser Interferometer Gravitational Wave Observatory |
| LN ₂ | Liquid Nitrogen Trap |
| M | Metal Sealed Valve |
| P | Pirani Gauge |
| PCF | Pound/Cubic-Foot |
| PSI | Process Systems International |
| PLC | Programmable Logic Controller |
| RGA | Residual Gas Analyzer |
| RP | Blanked Port for Roots and Turbo Pumps |
| TBS | To Be Supply |
| V | Viton Sealed Valve |

LIGO-DRAFT

1.3. Applicable Documents

1.3.1. LIGO Documents

- M950001 Project Management Plan, latest revision
- E950018 Science Requirements Document, latest revision
- E950020 Beam Tube Module Requirements-Fabrication & Installation Contract, latest revision
- E960123 Beam Tube Bakeout Design Requirements Document, latest revision
- E940002 Vacuum Equipment Specification, latest revision
- E94xxxx Beam Tube Module Specification (formerly Specification No. 1100004)
- E94xxxx Process Specification for Low Hydrogen, Type 304L Stainless Steel Vacuum Products (formerly Specification No. 1100007)
- M96xxxx Configuration Management Plan, latest revision
- M950046 Project System Safety Plan, latest revision
- E950089 Interface Control Document (ICD): Beam Tube (BT) - Civil Construction (CC), latest revision
- D950027 Beam Tube Pump Port Hardware, latest revision

1.3.2. Non-LIGO Documents

TBD

LIGO-DRAFT

2 OVERVIEW

The salient features of the LIGO beam tubes which affect the design of the bakeout are summarized here. The beam tube will be baked out in increments of 2 kilometer modules. The LIGO beam tube modules are stainless steel vacuum vessels, 1.2 m diameter by 2 km long. There are four such modules at each of two sites (8 total). Each vessel consists of 50 sections of stainless steel thin-wall (3.2 mm wall thickness) tubing, each 40 m long, separated by a stainless steel expansion joint designed to accommodate the thermal expansion of the 40 m sections during a bakeout. The tube sections are supported by structures designed to accommodate the thermal expansion and to minimize heat loss through the mechanical connections. The tube sections and expansion joints are welded together to form a continuous leak-tight tube. The ends of the 2 km long modules are terminated by 122 cm gate valves. There are nine 250 mm diameter pumping ports distributed at 250 m intervals along the module. The beam tube is enclosed in a concrete protective cover with access doors at each pump port location (there are also emergency accesses between the pump ports).

The beam tube bakeout design must meet the requirements given in the Beam Tube Bakeout Design Requirements Document, LIGO-E960123. The basic plan is to heat each beam tube module to ~ 150 °C under high vacuum for ~ 30 days, with sufficient pumping speed to remove adsorbed water and contaminants. The key elements of the conceptual design to do this are illustrated in schematic form in Figure 1 (here, to aid visualization, the beam tube is regarded simply as a vacuum vessel, stripped of its unusual geometry). The eight beam tube modules are baked sequentially, with equipment moved from one module to the next.¹ The elements are:

- **Insulation**, which reduces heat loss during bakeout from the hot vacuum vessel to an economical level and increases the thermal time constant of the vacuum vessel, reducing temperature dependence (both during bake and afterwards) on the ambient environment. Insulation will be wrapped around the entire length, ends and ports of a beam tube module.
- A **heater**, which dissipates energy from the local power company to raise the temperature of the vacuum vessel. The proposed bakeout system will heat the beam tube module with direct current flowing through the shell of the beam tube. Heating is by power loss in the resistance of the stainless steel shell (I^2R).
- The **heater power source**, which consists of the local power company which provides the electrical energy, AC transformers and wiring to deliver the power to DC power supplies which in turn convert the power to voltages and currents suitable for the heater, and attendant electrical wiring.
- A **heater controller**, which receives a signal from the **control temperature sensor** and adjusts the power delivered to the heater to maintain a constant temperature of the vacuum vessel.
- The **bake pumps**, which remove gases evolved during the bakeout and maintain a vacuum in the vacuum vessel.
- A **residual gas analyzer (RGA)**, a mass spectrometer which measures the partial pressures of residual gas in the vacuum vessel.

1. Currently it is assumed that it is most economical to leave the insulation and temperature sensors in place on each beam tube module, but this assumption is not crucial to the conceptual design.

- A **monitor system** which includes sensors (temperature of vacuum vessel, power supply currents and voltages, environmental parameters such as outside temperature and wind speed, and other engineering parameters as needed), data acquisition and display, and data recording. Data display and recording for the RGA will be separate from the monitor system, since these features can be purchased as options with the RGA controller, and data can be merged after-the-fact.

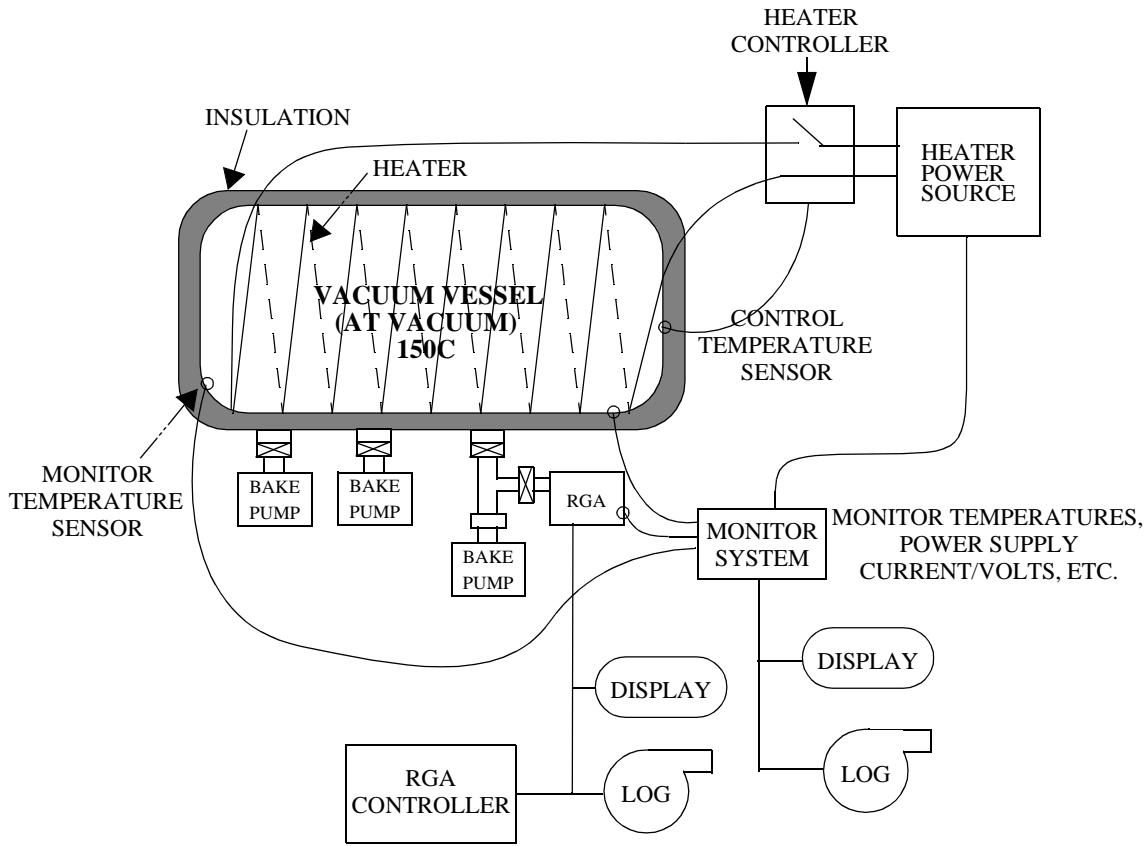

Figure 1: Schematic diagram of equipment during bakeout and cooldown

After the beam tube has been baked sufficiently, it is allowed to cool down (by shutting down the heater power) while continuing to pump. The heating equipment (heater power source and controller) can be immediately moved to the next beam tube module to be baked. After reaching ambient temperature, measurements are made of the residual gases in the beam tube to verify the success of the bakeout and to determine with maximum sensitivity whether any air leaks are present. The pumping speed needed is much lower than during the bake, and the RGA sensitivity needed is higher. To maximize equipment usage, the plan is to remove the pumps and RGA used during the bakeout and install them on the next beam tube module to be baked. A pump and RGA dedicated to post-bake measurements are then installed. This simplified equipment arrangement is illustrated schematically in Figure 2, where the nomenclature is the same as that defined above.

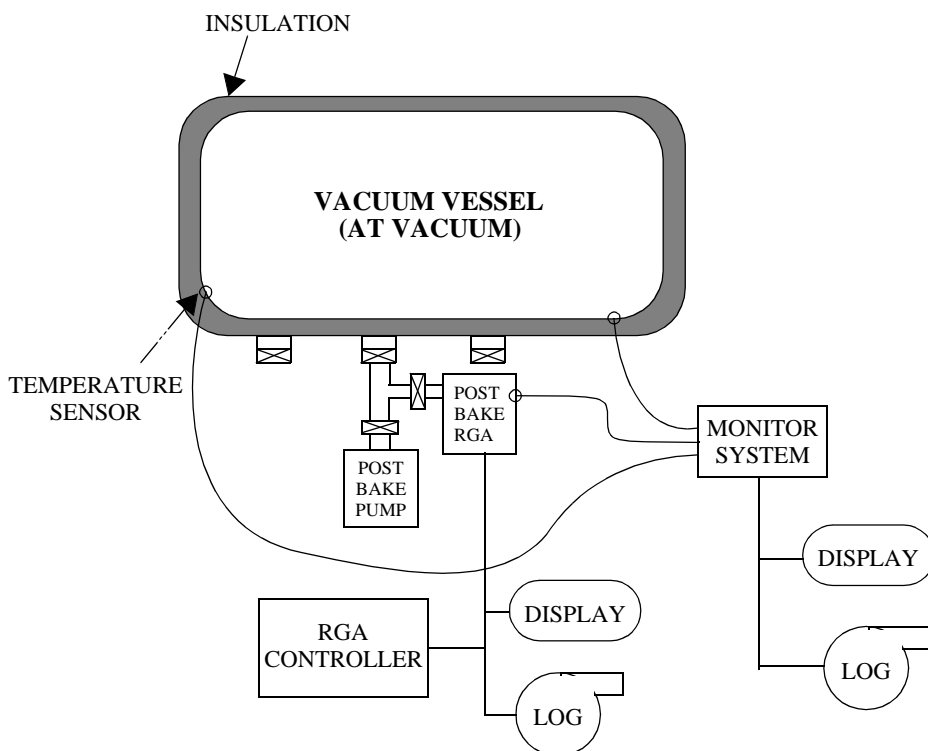

Figure 2: Schematic diagram of equipment during post-bake measurements

3 TECHNICAL DESCRIPTION

3.1. INSULATION

3.1.1. Tube Walls

The insulation consists of two layers of thermal insulation materials (see Figure 3). The first (inner) blanket layer is a 1.1 lb/ft³, 4 inch thick inorganic glass fiber blanket material bonded together by a high-temperature thermosetting resin. The inner blanket material is rated for 500°C. The second (outer) layer is a 0.75 lb/ft³, 2 inch thick inorganic glass fiber duct wrap rated for 120°C. The inside layer will be installed in wraps which match the stiffener ring spacing (~30 inch wide) and secured in place with aluminum bands. The outer layer will be installed over the inner layer with staggered seams, and also secured by bands. The outer layer has an aluminum foil scrim facing on the outside to block moisture penetration and reduce radiation losses; the joints will be sealed with aluminum foil scrim adhesive tape.

The two layers, a total of 6 inches thick, provide a combined thermal conductivity of 5.5 mW/cm² of beam tube surface area (220 W/m of beam tube length) at a beam tube temperature of 150 °C and a thermal time constant of about 9 hours.

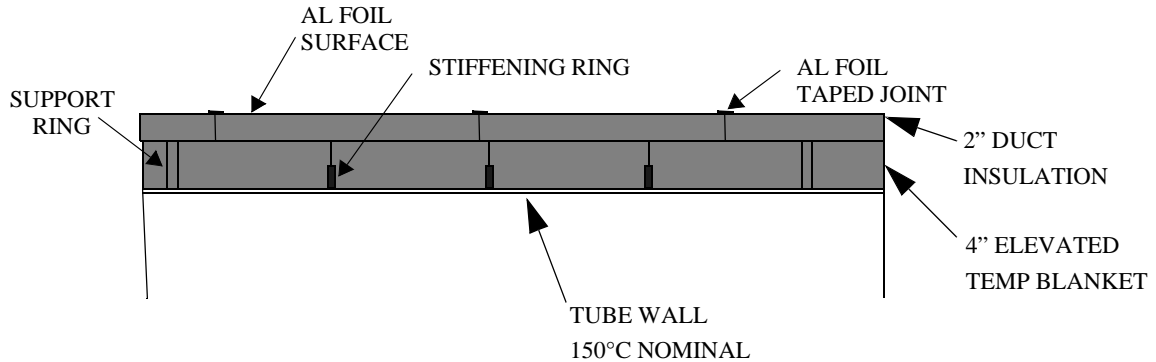

Figure 3: Tube wall insulation (section view)

3.1.2. Bellows

The bellows convolutions and thinner (2.7 mm) wall thickness lead to increased heat loss per unit length. To compensate for the higher heat dissipation per unit length, the insulation thickness at the bellows will be reduced by omitting the inner 4 inch layer (Figure 4).

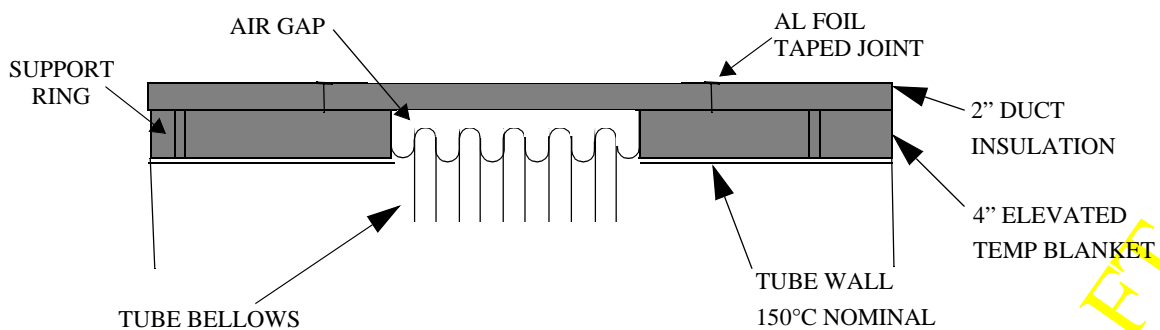

Figure 4: Bellows insulation (section view)

3.1.3. Supports

An additional wrap of one layer insulation will be installed at support points to account for increased conductive losses through supports.

3.1.4. Ends and Pump Ports

The ends of the beam tube module are connected to the 122 cm gate valves. The 122 cm gate valves and the nine pump ports will be insulated with custom fitted thermal heater jackets similar to those designed by PSI for the bakeout of the LIGO Vacuum Equipment. The thermal jackets will be purchased directly by LIGO for the beam tube bakeout.

3.2. Heating Power and Control

3.2.1. AC Source/Distribution

The power to be used for the bakeout will be supplied by the 13.8 kV (WA, 13.2 kV in LA) AC power available along the beam tube every 250m and provided by the local site public utility. The 13.8 kV, 1300 kVA power line (WA) (13.2 kV, 1300 kVA in LA) is housed in subsurface electrical vaults along the arms and across the service road from the beam tube service entrances.

The 13.8 kV power will be converted down to 480 VAC, 3Ø and brought to the beam tube module stub-ups near the service entrances by the local public utility (Figures 5 and 6). Power transformers for the high power DC heating will be provided at four locations along the beam tube module (see Figure 5). These transformers will be moved with the DC power supplies to each beam tube module. Separate (because they are moved at a different time) transformers and power distribution panels with 480 VAC, 3Ø and 120VAC, 1Ø power for pumps, instrumentation and smaller equipment will be supplied and installed at seven locations along the beam tube module (see Figure 6).

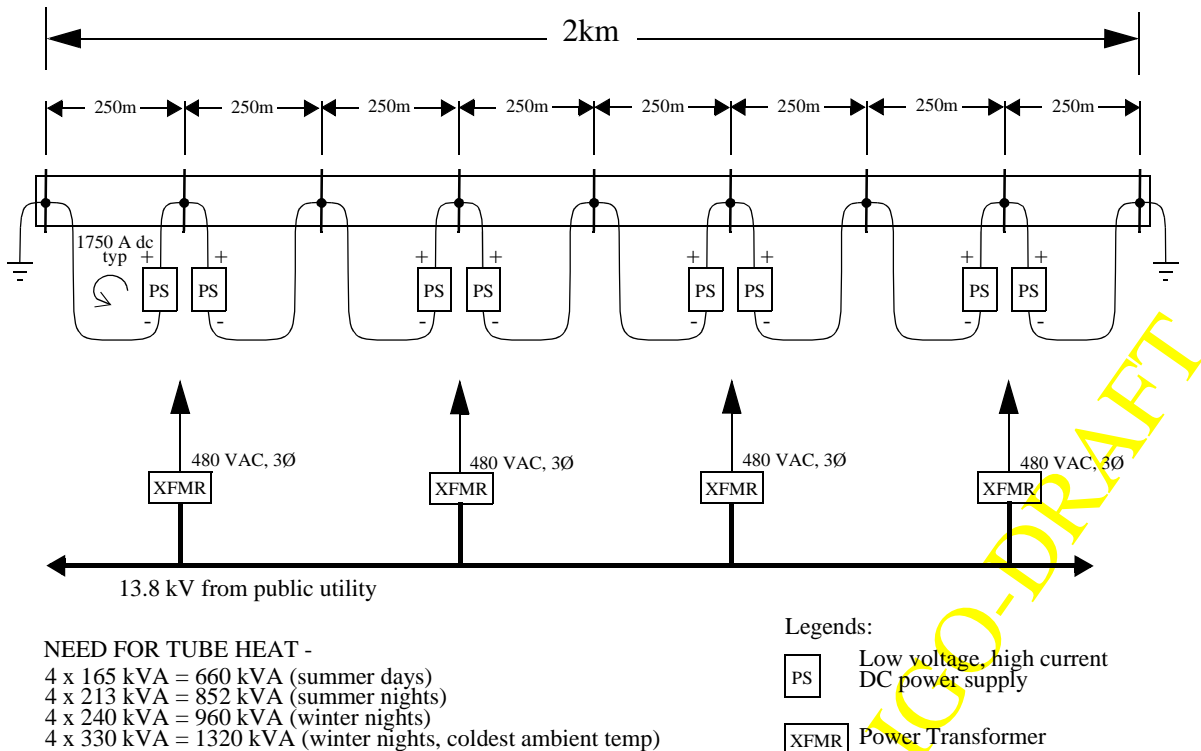

Figure 5: Heating power source layout

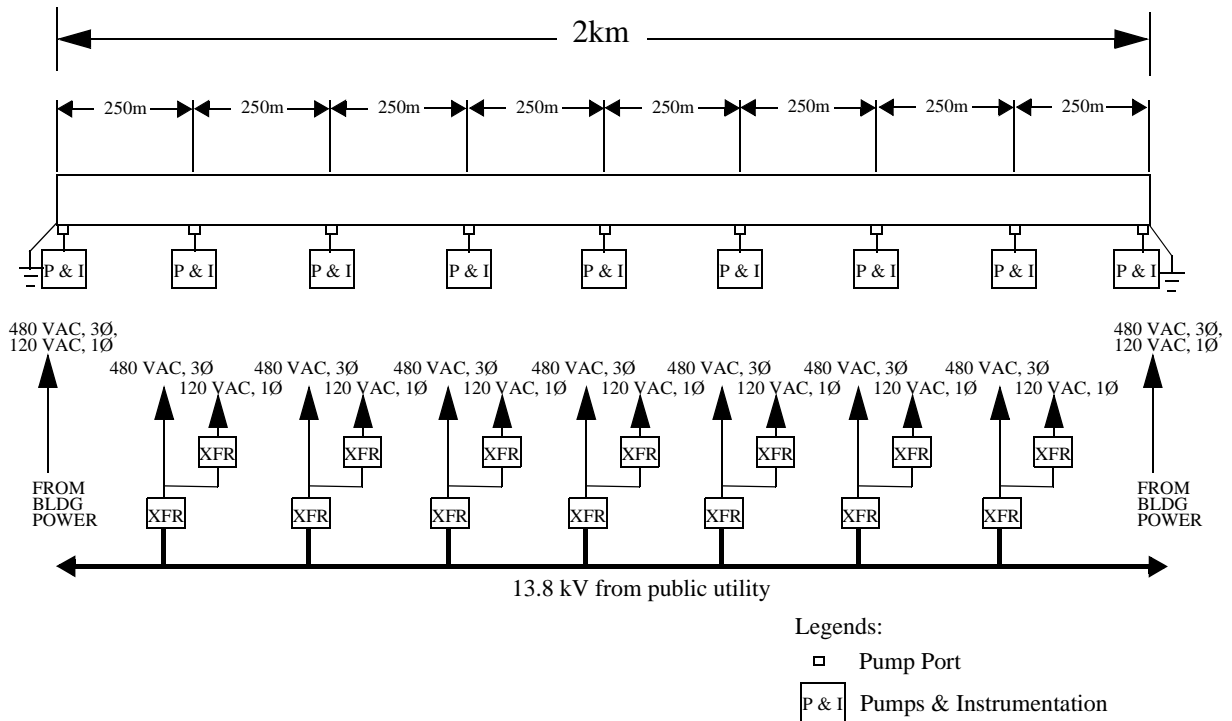

Figure 6: Power distribution for pumps and instrumentation

3.2.2. DC Power Supplies

Each of the eight 250m sections will have two 1000 A power supplies connected in parallel (Figure 7). A total of 16 power supplies are required for the bakeout of a module. The power supplies will be grouped into four clusters of four units each at 500m intervals along the beam tube (see Figure 5). The DC power supplies will be operating nominally at 35 V and at 1750 A. One of the two DC power supplies will be adjusted to provide a constant current of 1000 A. The second DC power supply will be controlled using temperature feedback (see next section).

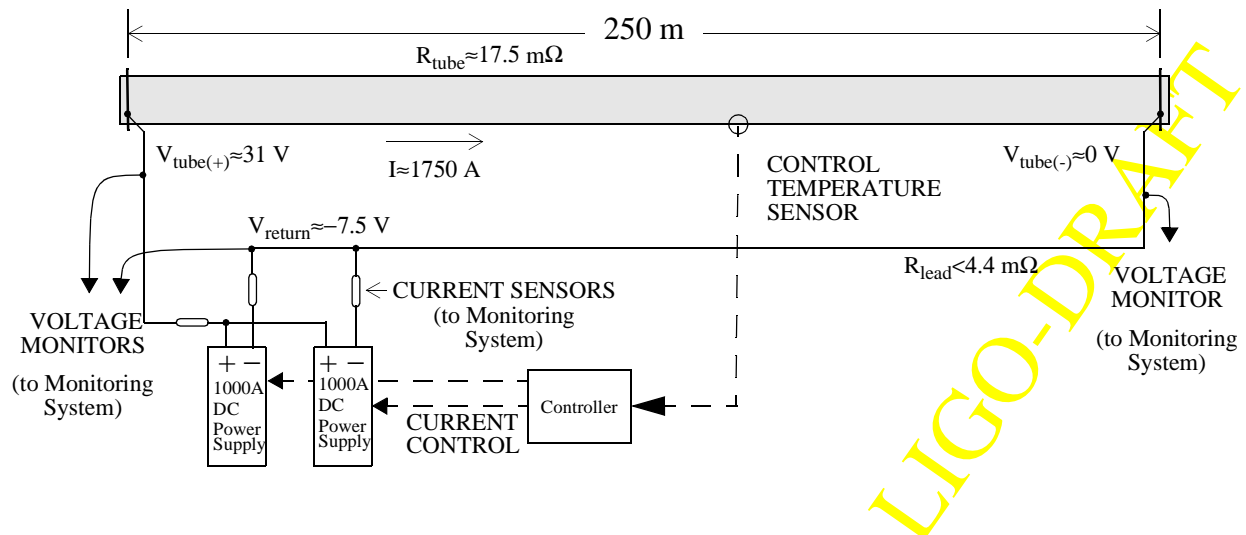

Figure 7: DC power supply control and connections to beam tube

The 1000 A DC power supplies to be used for the beam tube module heating will be commercial grade arc welding power sources with acceptable characteristics on both constant voltage and constant current usage. They have a power factor of 0.74 and power efficiency of 79% at an operating load of 1200 A. The power supplies will be able to operating continuously at 100% duty cycle for more than 30 days. The power supplies can be controlled by an external voltage (0 to 10 V) to adjust the output current.

3.2.3. Temperature Control of Tube Wall

The beam tube bakeout temperatures will be ramped up in 10 °C steps to a nominal bakeout temperature of 150 °C. The temperature is controlled by adjusting the current output of the DC power supplies which in turn are controlled by four I/O modules located at the power supply clusters, connected to the monitoring system I/O bus (see Section 3.4). The control function will be implemented in the monitoring system computer (a PC running a commercial data acquisition and control software program). Temperature feedback information from designated beam tube temperature sensors as well as DC current and voltage information from the current sensors will be used to adjust the currents in each of the eight 250 m loops to maintain a temperature set by the operator (see Figure 7).

3.2.4. Heating and Temperature Control of Ends/Ports

The gate valves at the ends of the module and the pump port hardware along the module will be heated to bake temperature with custom thermal heater jackets fit tightly over the gate valves, termination anchor supports and pump inlets. The jacketed elements will be maintained at the bake temperature with standalone, manually operated temperature controllers and dedicated temperature sensors, separate from the monitoring system. Power for the gate valve and pump port hardware bakeout heaters and controllers will be provided from the power distribution panels.

3.3. VACUUM PUMPS AND VACUUM INSTRUMENTATION

3.3.1. Vacuum Pumping and Monitoring During Bakeout

Pumping during bakeout will be provided by one 500 liter/second(l/s) turbomolecular pump for pumping H₂ and other non-condensable gases and nine 10 inch He cryo (refrigerating) pumps for pumping of H₂O and other condensable gases. The arrangement of shown schematically in Figure 8. The cryo pumps will be commercially available single stage refrigeration units, cooled by refrigeration compressors located near the pump ports. The pumping surface temperature is adjustable and will be set to 100 K. The cryo pumps will provide about 2,500 l/s pumping speed for H₂O at each port, which yields the same pump speed per unit of beam tube surface area as used during the earlier beam tube qualification test (QT). Power for the vacuum pump hardware will be provided from the power distribution panels.

Partial pressures will be monitored during the bakeout and cool down by a single RGA located at the module mid-point (see Figure 8). The RGA output will be displayed and recorded remotely at the location of the monitoring system display and operator's controls for the bake temperature. A cold cathode gauge to measure total pressure and a Pirani gauge to measure turbo pump back-pressure will be connected to the monitoring system (Section 3.4).

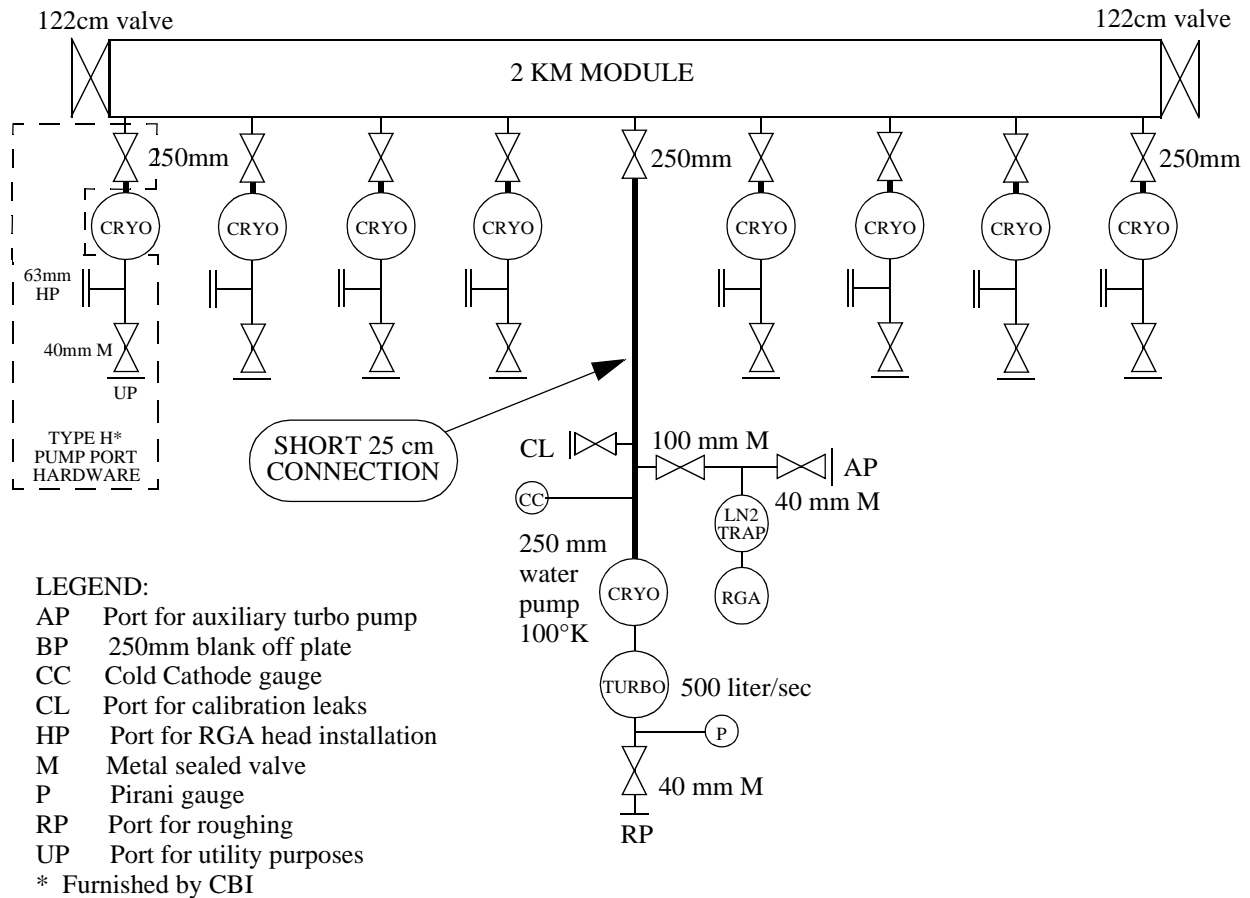

Figure 8: Schematic of vacuum pumps and RGA during bakeout

3.3.2. Vacuum Pumping and Measurement After Bakeout

Pumping during post-bake measurements will be provided by a single 500 l/s turbo pump. After the beam tube module has cooled to ambient temperature, the 250 mm gate valves will be closed and the bakeout pumps, RGA and associated hardware will be removed. A separate, clean turbo pump will be installed, along with a clean, pre-baked, high-sensitivity RGA, cold cathode and Pirani gauges. The RGA and gauges will have only local control and display (at the module mid-point). The equipment arrangement is shown in Figure 9. The expected partial pressures are shown in Table 1. A portable calibration module (Figure 10) will be used to verify RGA partial pressure measurements.

Table 1: Estimated Partial Pressures at 23 °C After Bakeout

| | Mid-point Pressure (torr) |
|-------------------------------|---------------------------|
| H ₂ | $< 7 \times 10^{-9}$ |
| CO | $< 8 \times 10^{-11}$ |
| CO ₂ | $< 3 \times 10^{-11}$ |
| H ₂ O | $< 1.4 \times 10^{-12}$ |
| Hydrocarbons Σ 41,43,55,57 | $< 1.8 \times 10^{-12}$ |

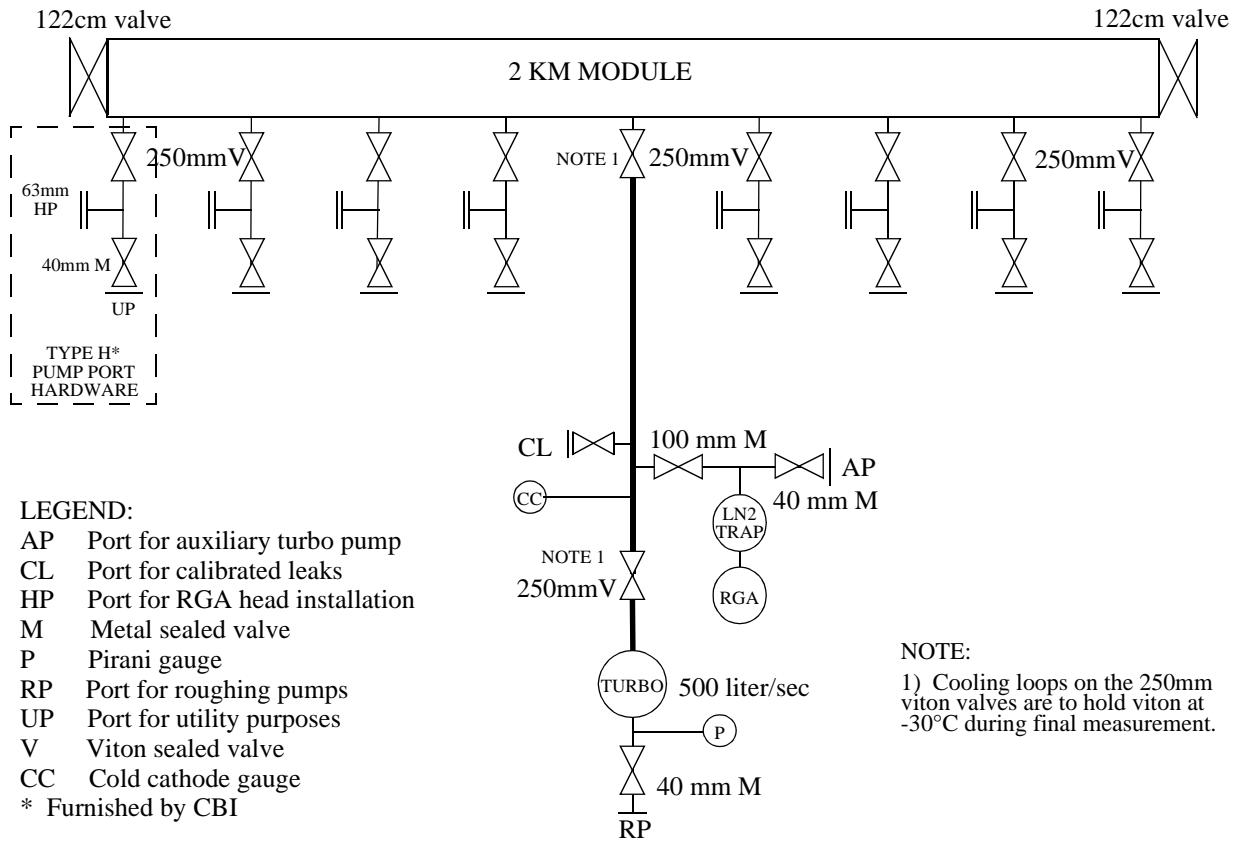

Figure 9: Final (post-bake) test configuration

LIGO-DA

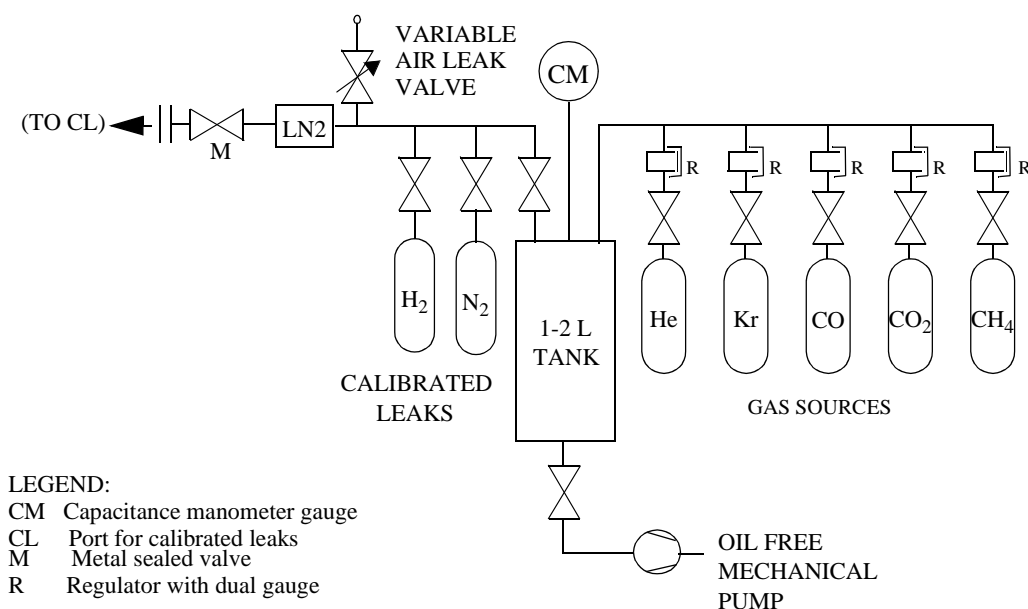

Figure 10: Portable Calibration Module

3.4. MONITORING SYSTEM

The monitoring system will consist of a standard PC computer running a commercial data acquisition and control software program. Commercially available I/O modules operating on a proprietary I/O bus with a range of 7,500 ft will be distributed along the beam tube module to measure temperatures, power supply electrical parameters, pressures, and equipment status and provide analog outputs to control the DC power supplies. The layout is shown schematically in Figure 11.

Table 2 provides a sample list of measurement channels. Temperature measurements will be taken at representative locations, mostly concentrated around the tube ends and pump ports, to ensure that the temperature behavior of the entire beam tube module is understood. Selected temperature channels will be used to set the current outputs of the power supplies to maintain all sections of the beam tube at a temperature set by the operator.

From the computer operator interface terminal, the operator will be able to access, record and alarm all DC current and voltage data and all temperature data. A complete sample of all data (< 256 channels) will take about 1 Kbyte, so if samples are logged once per minute, a 30 day bakeout will need about 50 Mbyte, which can easily fit onto the PC's hard disk drive. An ethernet connection to the corner station's networking facilities will allow the data to be downloaded over the Internet for permanent archiving and remote analysis.

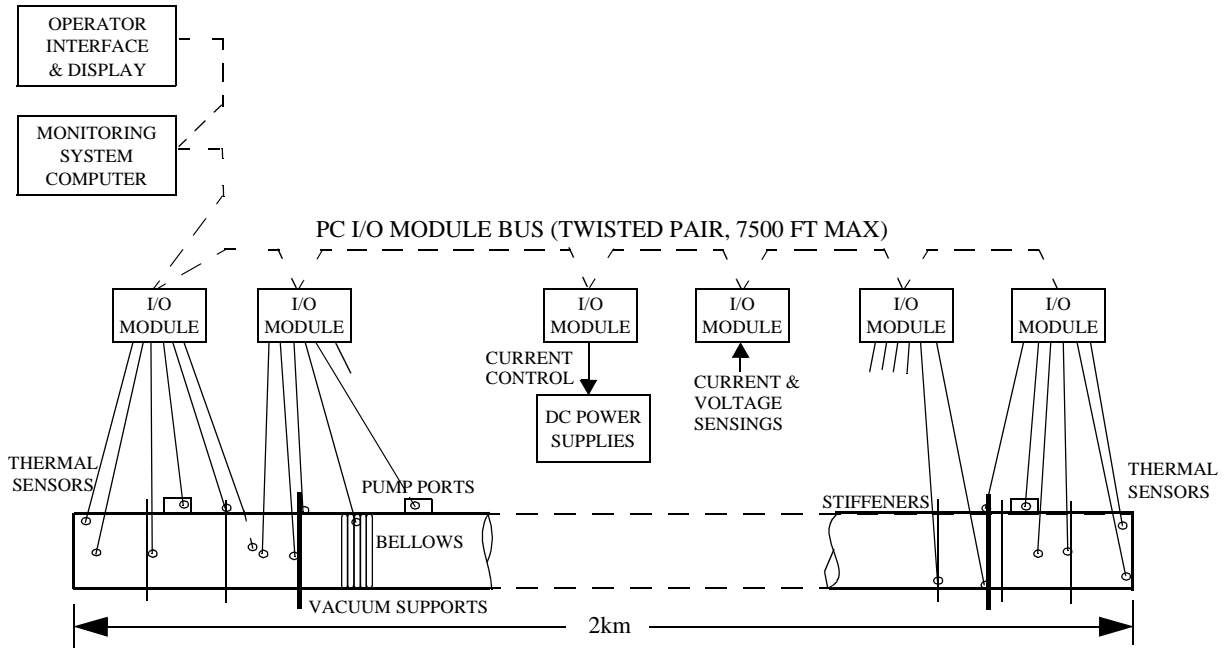

Figure 11: Monitoring system layout

Table 2: Monitoring System Channels

| Signal Name | Station (m) | Description |
|---|-------------|--|
| Temperatures: | | |
| T1-T32 | | Temperatures at near end beam tube gate valve, pump port, and tube wall in representative locations along the first 100 m of beam tube |
| T33-T64 | | Temperatures at far end beam tube gate valve, pump port, and tube wall in representative locations along the last 100 m of beam tube |
| T65-T106 | | Six representative temperatures at each pump port location (7 places) |
| T107 | | Ambient air temperature (outside) |
| T108 | | Ambient air temperature inside enclosure |
| T109-T128 | | Spare channels |
| Bakeout power supply electrical: | | |
| V1-V4 | | Voltages on tube and at power supply for first heater section |
| V5-V32 | | Voltages on tube/power supplies for remaining 7 heater sections |
| I1-I3 | | Currents in + and - power supply legs for first heater section |
| I4-I24 | | Currents for remaining 7 power supplies |

Table 2: Monitoring System Channels

| | | | |
|---|--|---|--|
| Vacuum gauges: | | | |
| P1-P3 | | Pressures at cold cathode, Pirani and capacitance manometer (Calibration Module) gauges | |
| RGA1 | | RGA analog output | |
| Miscellaneous channels and status indicators: | | | |
| W1 | | Digital output from weather station (wind speed, temperature, humidity) | |
| CR1-CR9 | | Status of cryo pumps | |
| TP1 | | Status of turbo pump | |
| CT1-CT9 | | Cold trap stations | |
| LN1 | | Status of LN2 trap at RGA | |
| ETC1 | | Etc. | |
| Output channels: | | | |
| PS1-PS16 | | Set current outputs of the 16 DC power supplies for heating | |

LIGO-DRAFT