

- NOTES CONTINUED:
5. SCRIBE, ENGRAVE (A VIBRATORY TOOL MAY BE USED), LASER MARK OR MECHANICALLY STAMP (NO INKS OR DYES) DRAWING PART NUMBER, REVISION (AND VARIANT OR "TYPE" IF APPLICABLE) ON NOTED SURFACE OF PART FOLLOWED ON THE NEXT LINE WITH A THREE DIGIT SERIAL NUMBER. SERIAL NUMBERS START AT 001 FOR THE FIRST ARTICLE AND PROCEED CONSECUTIVELY. USE MINIMUM 0.12" HIGH CHARACTERS, UNLESS THE SIZE OF THE PART DICTATES SMALLER CHARACTERS. EXAMPLE: DXXXXXX-VY, TYPE-XX, S/N XXX
  6. APPROXIMATE WEIGHT = 4.773 LB.
  7. MACHINE ALL SURFACES TO REMOVE OXIDES AND MILL FINISH. USE OF ABRASIVE REMOVAL TECHNIQUES IS NOT ALLOWED. REFER TO LIGO-E0900364
  8. ALL PARTS SHALL BE MANUFACTURED IN ACCORDANCE WITH LIGO SPECIFICATION E0900364.
  9. ALL MATERIAL IS TO BE VIRGIN MATERIAL (i.e. NO WELD REPAIRS, PLUGS OR RECYCLED MATERIAL). NO REPAIRS SHALL BE MADE UNLESS APPROVED IN ADVANCE, AND IN WRITING, BY LIGO LABORATORY. REFER TO LIGO-E0900364.
  10. SURFACE FINISH TO BE AS-PROCESSED FROM MILL/SUPPLIER, FREE FROM SCRATCHES OR GOUGES.

REV.	DATE	DCN #	DRAWING TREE #
v2	16 FEB 2011	E1000883-v2	E1000884-v2

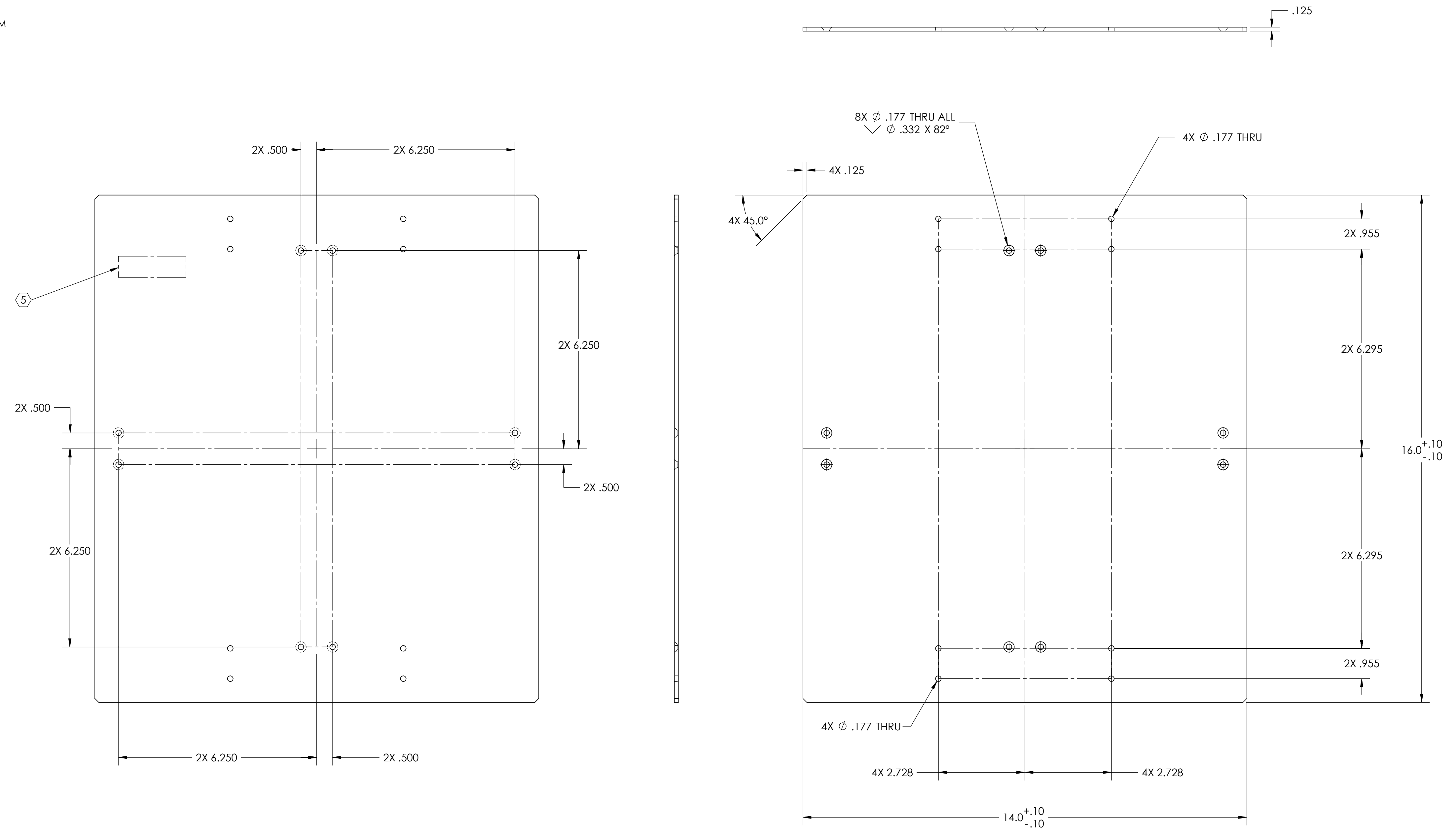

NOTES AND TOLERANCES: (UNLESS OTHERWISE SPECIFIED)				LIGO CALIFORNIA INSTITUTE OF TECHNOLOGY MASSACHUSETTS INSTITUTE OF TECHNOLOGY		PART NAME	
DIMENSIONS ARE IN INCHES TOLERANCES: .XX $\pm$ .01 .XXX $\pm$ .005 ANGULAR $\pm$ 0.5°				1. INTERPRET DRAWING PER ASME Y14.5-1994. 2. REMOVE ALL SHARP EDGES, .005-.015, FOR MACHINED PARTS. 3. DO NOT SCALE FROM DRAWING. 4. ALL MACHINING FLUIDS MUST BE FULLY SYNTHETIC, FULLY WATER SOLUBLE AND FREE OF SULFUR, SILICONE, AND CHLORINE.		<b>aLIGO TCS FIXTURE BASE PLATE</b>	
<b>MATERIAL</b> 6061 Alloy		<b>FINISH</b> 63 $\mu$ inch		<b>SYSTEM</b> ADVANCED LIGO		<b>SUB-SYSTEM</b> AOS	
<b>NEXT ASSY</b> D1100263				<b>DESIGNER</b> M. JACOBSON		<b>DATE</b> 10 FEB 2011	
<b>APPROVAL</b> P. WILLEMS				<b>CHECKER</b> J. LEWIS		<b>DATE</b> 15 FEB 2011	
<b>SCALE:</b> 1:2				<b>PROJECTION:</b>		<b>SIZE</b> <b>DWG. NO.</b> <b>D</b> <b>D1100265</b>	
<b>REVISION</b> v2				<b>SHEET 1 OF 1</b>			

D1100265\_aLIGO TCS FIXTURE BASE PLATE, PART PDM, REV: X-007, DRAWING, PDM, REV: X-004