

LIGO ADVANCED SYSTEM TEST INTERFEROMETER

Conceptual Design Review
LIGO Science Collaboration Meeting
17 August, 2000

M. E. Zucker, D. Shoemaker, K. Mason

G000203-00-R

Mission

- Test LIGO components, systems at full mechanical scale
- Practice installation & commissioning
- Minimize delays & downtime for LIGO site upgrades

LIGO II specialization:

- Test LIGO II seismic isolation & suspension system and associated controls at full scale
- Develop detailed SEI/SUS installation & commissioning handbook
- Look for unforeseen interactions & excess displacement noise
- Goal: complementarity to 40m, other performance demonstrations

Plan

- Set up and test the **infrastructure**: vacuum system, optical sensing system, and data handling
- test **seismic isolation** systems 'stand-alone' using seismometers
- to measure **relative displacement** between the two seismic systems using interferometry
- to test the **suspensions** as stand-alone elements
- to assemble a **Mode Cleaner suspension cavity** between the two seismic isolation systems, perform tests of relative motion
- to form a short **Test-Mass suspension cavity** on the BSC isolation system, illuminated with mode-cleaned light, perform tests of relative motion
- Suspension tests to be done first for '**controls prototypes**' of the suspensions; and then for final '**noise performance prototypes**' of the suspensions.

Goals, Questions for this review

- Conceptual Design Review
 - want to proceed with design, acquisition of equipment
 - are our conceptual design and measurement goals consistent with the realistic aspirations for lab-scale tests of the mechanical system for the next generation LIGO
- Key questions:
 - Are we choosing a reasonable trade of sensitivity vs. heroism?
 - Is the system simple enough to succeed in the allotted time?
 - Are we at some kind of sweet spot for the exploitation of the installation and the manpower?
 - Can it respond to changes in the program due to (incremental) changes in suspension or isolation design, e.g., Sapphire/Silica?
 - additions of tasks (tests of the Mode Cleaner and possibly Laser)?
 - Is there a sense of the response to a different schedule for the next generation LIGO?

Vacuum envelope, left (S) arm

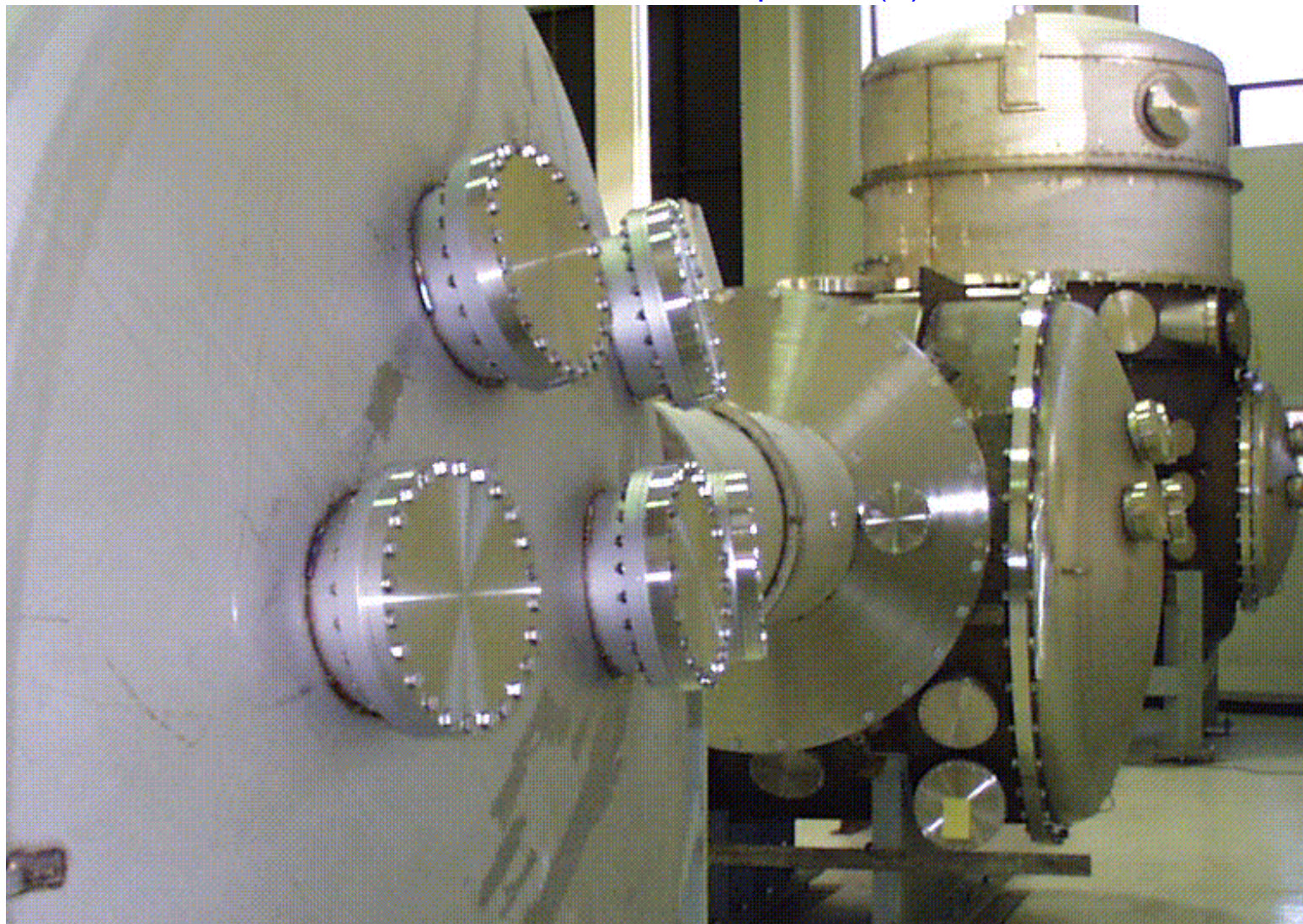

General vacuum equipment arrangement plan

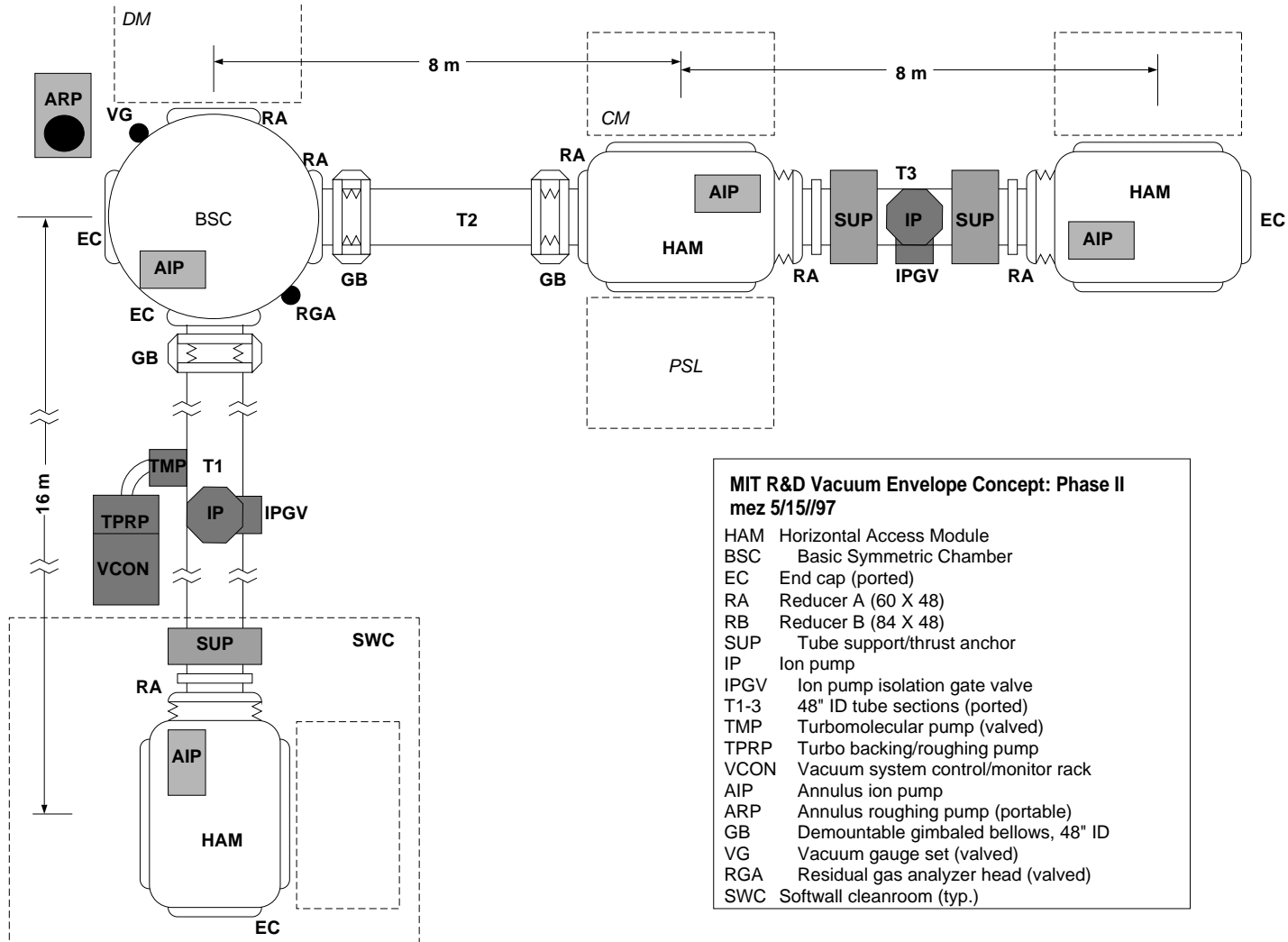

MIT R&D Vacuum Envelope Concept: Phase II mez 5/15/97

- HAM Horizontal Access Module
- BSC Basic Symmetric Chamber
- EC End cap (ported)
- RA Reducer A (60 X 48)
- RB Reducer B (84 X 48)
- SUP Tube support/thrust anchor
- IP Ion pump
- IPGV Ion pump isolation gate valve
- T1-3 48" ID tube sections (ported)
- TMP Turbomolecular pump (valved)
- TPRP Turbo backing/roughing pump
- VCON Vacuum system control/monitor rack
- AIP Annulus ion pump
- ARP Annulus roughing pump (portable)
- GB Demountable gimbaled bellows, 48" ID
- VG Vacuum gauge set (valved)
- RGA Residual gas analyzer head (valved)
- SWC Softwall cleanroom (typ.)

Test target

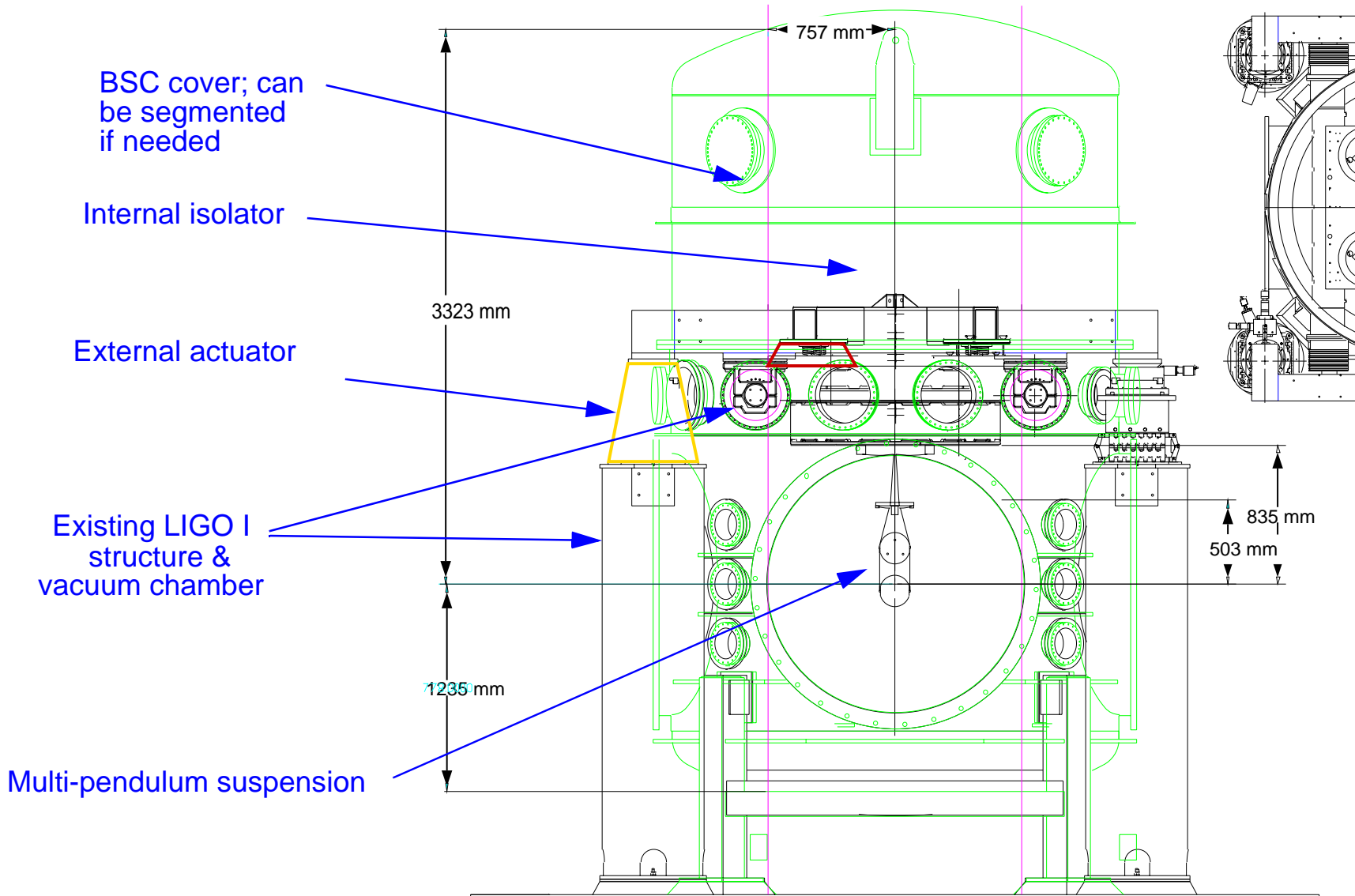

Proposed optical configuration

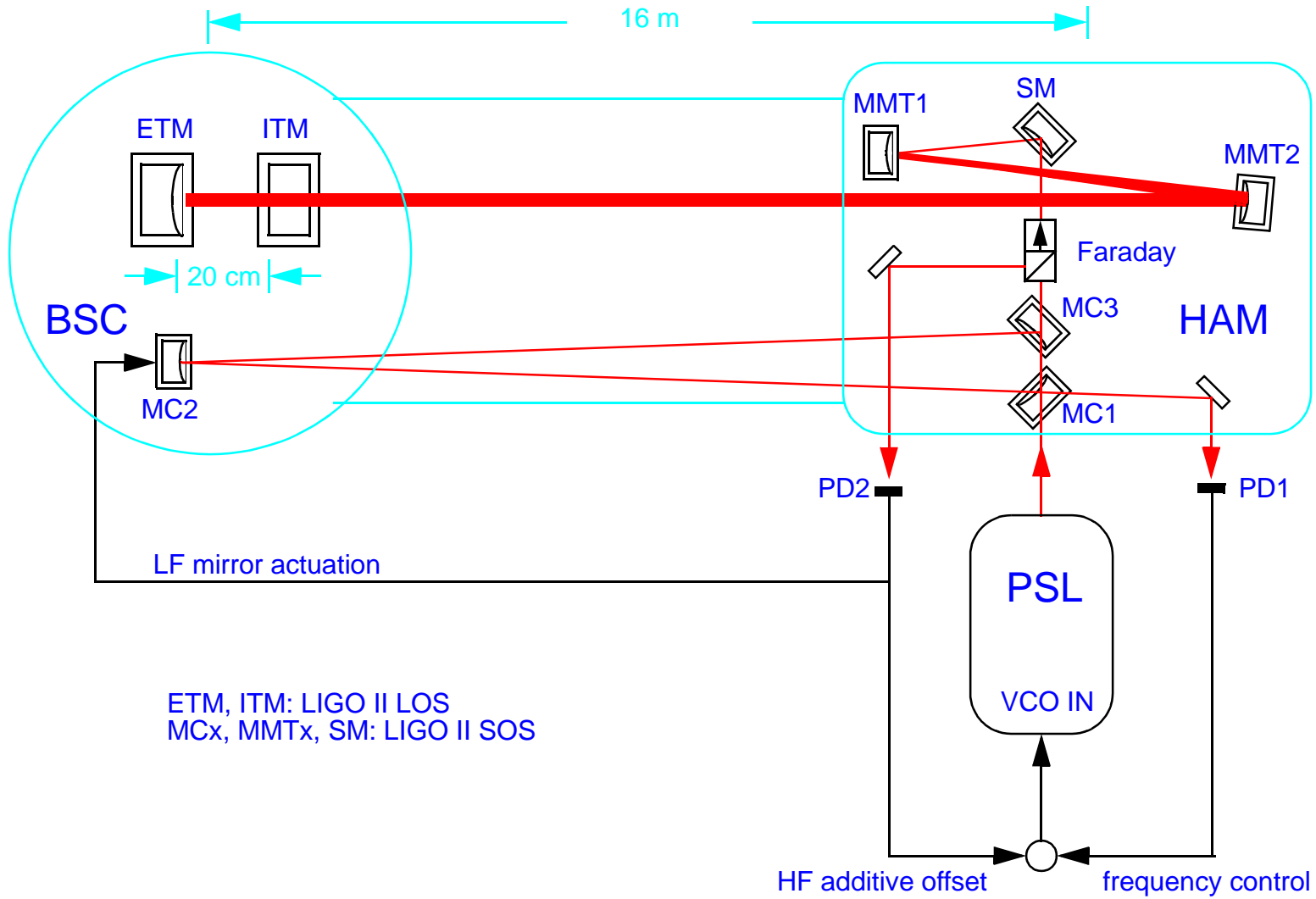

Measurement challenges and foci

- Thermal noise
- Seismic noise
- Sensing noises
- Pacing from subsystems
- Controls vs. noise testing
- Tests beyond seismic isolation and suspensions

Thermal noise

- Internal thermal noise will probably dominate spectrum (sapphire or silica masses)
 - could be frequency noise, esp. if silica test masses
- Beam spots smaller than LIGO
 - needs some theoretical work for small spots - maybe quieter?
- short cavity (0.1-1m): spot size $w \sim 0.5$ mm
- high-finesse and well-aligned nearly unstable cavity: $w \sim 5$ mm?
- long cavity (~ 16 m)
 - formed of one TM and one MC suspension
 - MC suspension noise critical; if fused silica fibers, probably ok
 - spot size ~ 5 mm if $g=1/3$, could possibly force a larger beam

Silica TM substrates

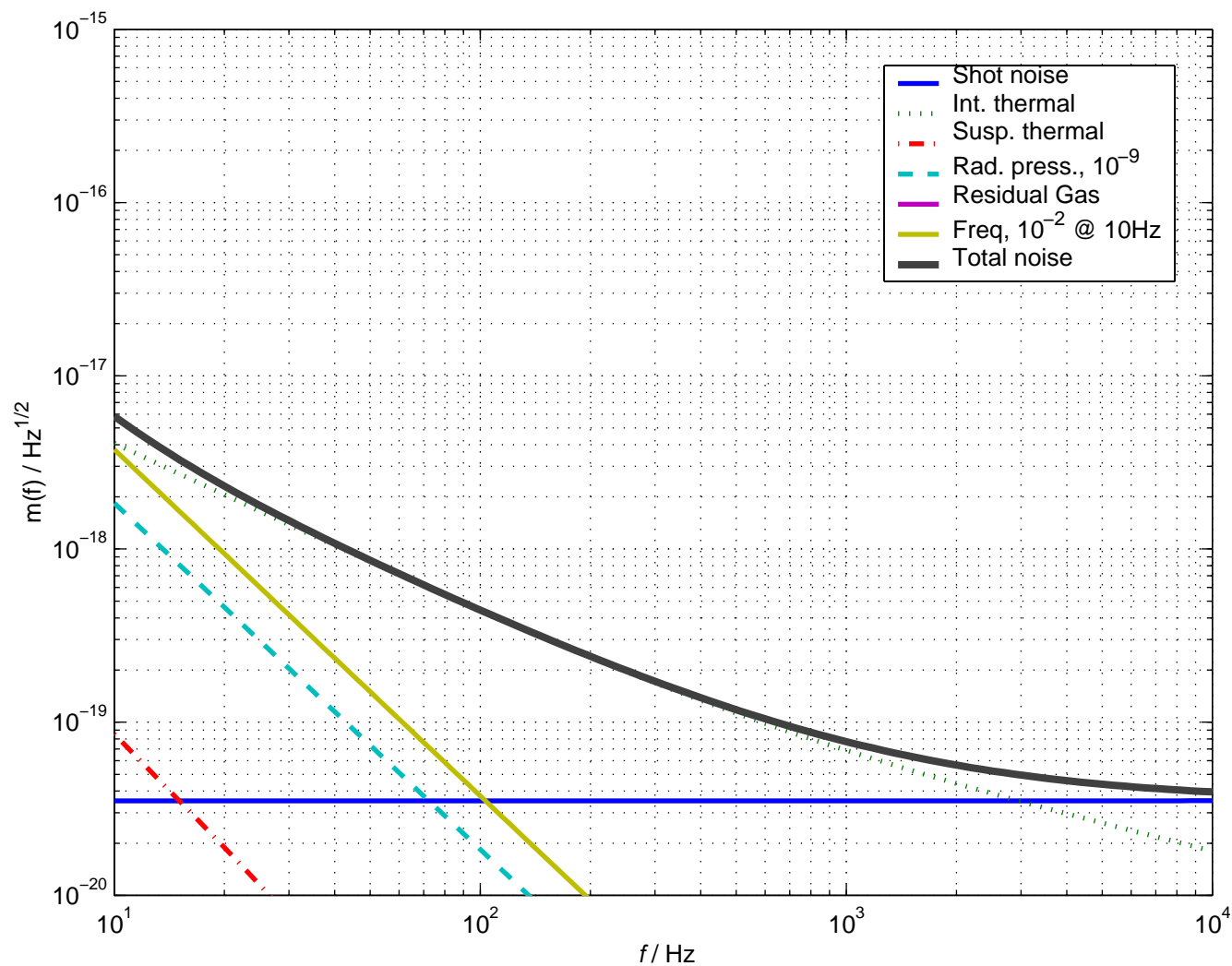

Sapphire TM substrates

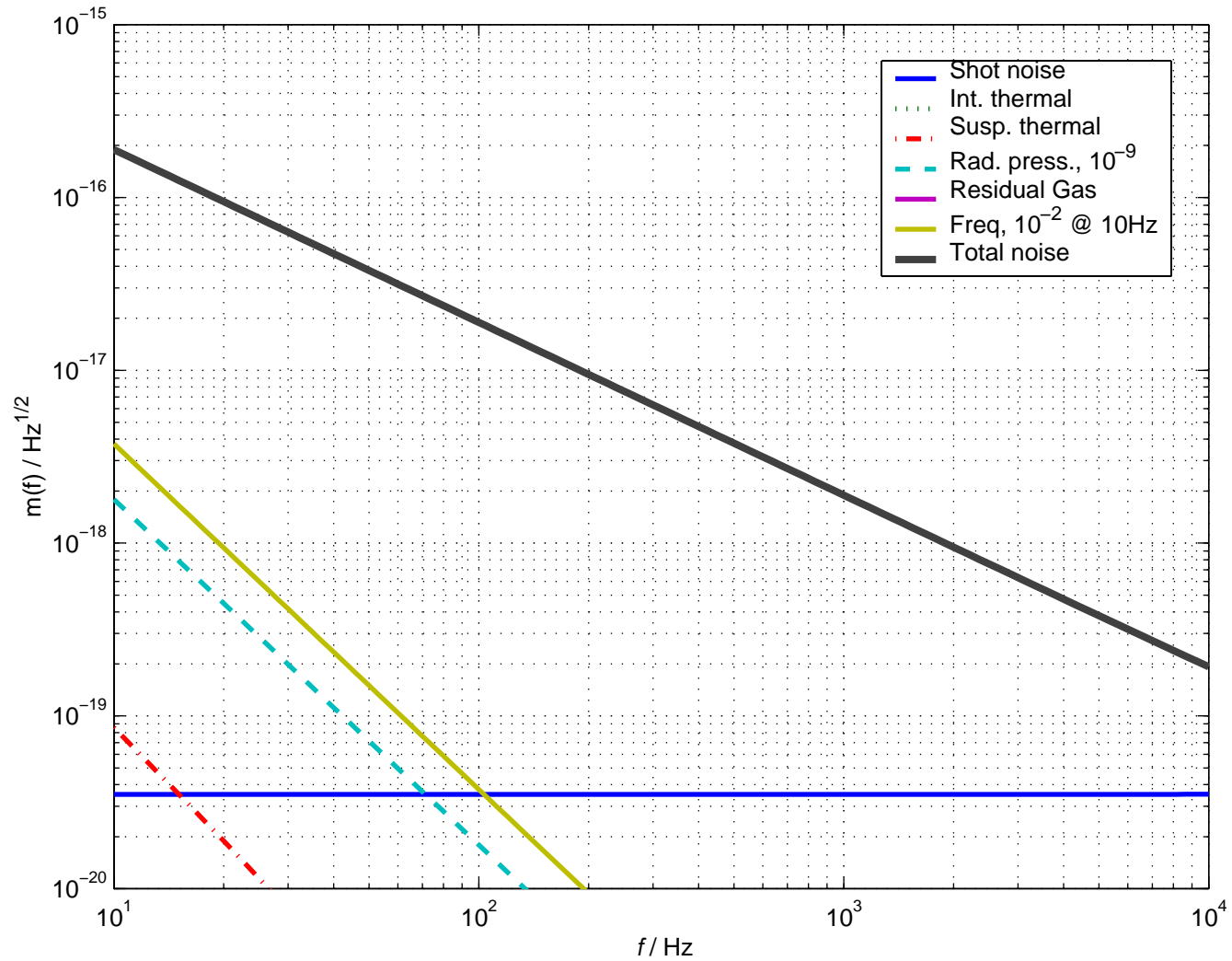

Seismic noise

- Seismic noise at MIT Campus site greater than sites
 - similar RMS (dynamic ranges ok, performance test realistic) larger at e.g., 10 Hz by 10x to 100x
 - makes only small change in test start frequency
- Stiff seismic isolation falling as $\sim 1/f^2$, so similar noise at 30 Hz to LIGO
- Suspension falling as $1/f^8$ (TM) or $1/f^6$ (MC); at LIGO noise by 15 Hz
- For masses on a common table, common mode motion to some level (10^2 ?)

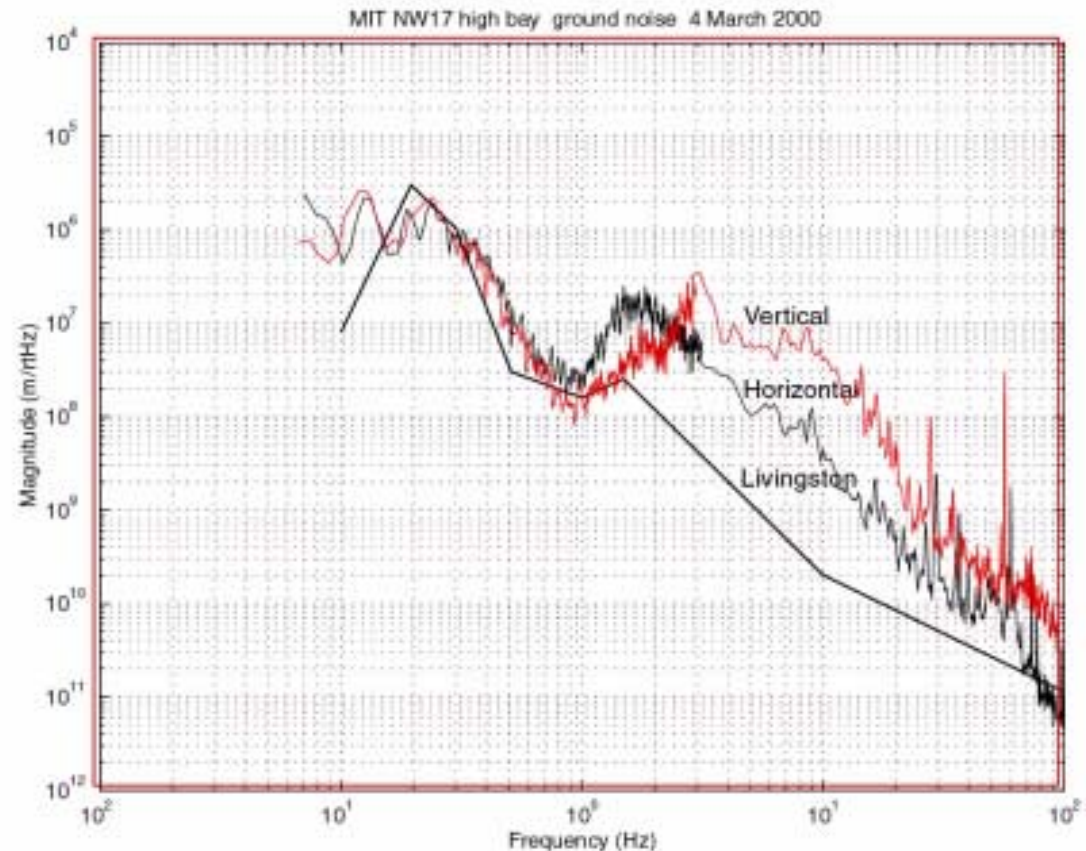

Frequency Noise

- minimum LIGO II MC requirement: 10^{-2} at 10 Hz, 10^{-3} at 100 Hz
- corresponds to $3e-16$ m/rHz for all three mirrors
- influence scales in ratio of length of TM cavity to MC cavity (typ. 1:50)
- more probable requirement $\sim 10^{-3}$ at 10 Hz, 10^{-4} at 100 Hz

- Shot Noise - want it well below thermal noise in broad frequency range; easy with LIGO I laser ($\sim 5-10$ W), finesse of both cavities ~ 2000
- Radiation pressure noise - ditto on requirement; assume 10^9 (LIGO II components but used at $< 1/10$ power)

Schedule constraints

- Interleaved availability of critical prototype hardware for nominal dates:
- HAM Seismic isolation pathfinder: available 3Q01
 - 2 months to assemble/install, 6 months of test
- ‘Controls’ suspension prototypes: 3Q01
 - 3 months to assemble, test in air
 - install as soon as the HAM isolation system is ‘safe’, 3 months test
- BSC Seismic isolation pathfinder: available 1Q02
 - 3Q01, 2 months to assemble/install, 6 months of test
- TM Controls suspension prototype - ready back in 3Q01?
 - install as soon as the BSC isolation system is ‘safe’, 3 months test
- Controls testing: a TM/BSC and MC/HAM cavity testbed, or.....
- ‘Noise’ suspension prototypes available 2Q03 - maybe jump over cavity testing with ‘Controls’ suspensions?

Controls vs Noise testing

- Cannot reasonably test at LIGO II displacement noise levels due to thermal noise
- All other infrastructure requirements become stiffer if strive ‘heroically’
- Controls testing is necessary, and possible, and a precursor to noise testing
- Propose to perform initial controls testing with just two suspensions: one TM, one MC, forming simple linear cavity
 - limits number of crude prototypes to be made
 - controls work can, nay, must continue with ‘noise’ suspensions
- PROBLEM: noise testing of actual LIGO II components will wait until actual installation, after commitment to designs and fabrication.
- Best solution involves clearly some noise testing. More time available, more testing.

Tests beyond suspension and isolation

- Can study many other controls problems perfectly, in particular
 - LIGO II mode cleaner: same length, same optics, same controls, the same environment in a practical sense
 - pre-stabilized laser: could install serial #1 LIGO II laser, test in hierarchical servo loop with mode cleaner and a test cavity
- First 6 months of LIGO II (I) commissioning could be (could have been) performed at LASTI.

Demands on subsystems

- Seismic Isolation
 - one HAM in 3Q01 (parts and people arrive)
 - one BSC in 1Q02 (parts and people)
 - may need external attenuator (agressive hydraulic system)
- Suspensions
 - (2 LIGO I SOS like suspensions/optics for start-up tests)
 - one MC ‘controls’ prototype (dummy masses, steel fibers) ready to install in 1Q02 (parts and people)
 - one TM controls prototype in 3Q02
 - 3 (or maybe 4) MC ‘noise’ (fused silica fibers) in 2Q03
 - 1 ITM ‘noise’ prototype in 2Q03
 - 1 ETM ‘noise’ prototype in 2Q03

Demands on subsystems

- Core Optics
 - (1” optics for ‘controls’ prototypes, 1Q02, 3Q02)
 - 3 (or maybe 4) MC real optics in 2Q03
 - 1ETM sapphire/silica optic in 2Q03 (can be e.g., a pathfinder)
 - 1 ‘custom’ (short radius of curvature, only good in center) ITM sapphire/silica optic in 2Q03
- Laser
 - 10 W LIGO I PSL in 4Q00
 - if pursued, LIGO II PSL in 1Q04 (complete and installed)
- Input Optics support
 - if MC testing pursued, modulation, controls to complement Mode Cleaner by ~2Q03

Demands on subsystems

- DAQ/GDS (by 4Q02)
 - small-scale LIGO I system; like 40m
 - just disk storage
- ISC (by 4Q02)
 - 2 LIGO I length photodiodes, demod
 - 4 quad alignment sensors, demod
 - subset of LIGO I controls (2 copies of LIGO I MC controls)
 - (controls for SUS and SEI delivered with them)
 - (supervisory control either LIGO I or LIGO II derived)

Proposed controls implementation (mostly 'generic LIGO II')

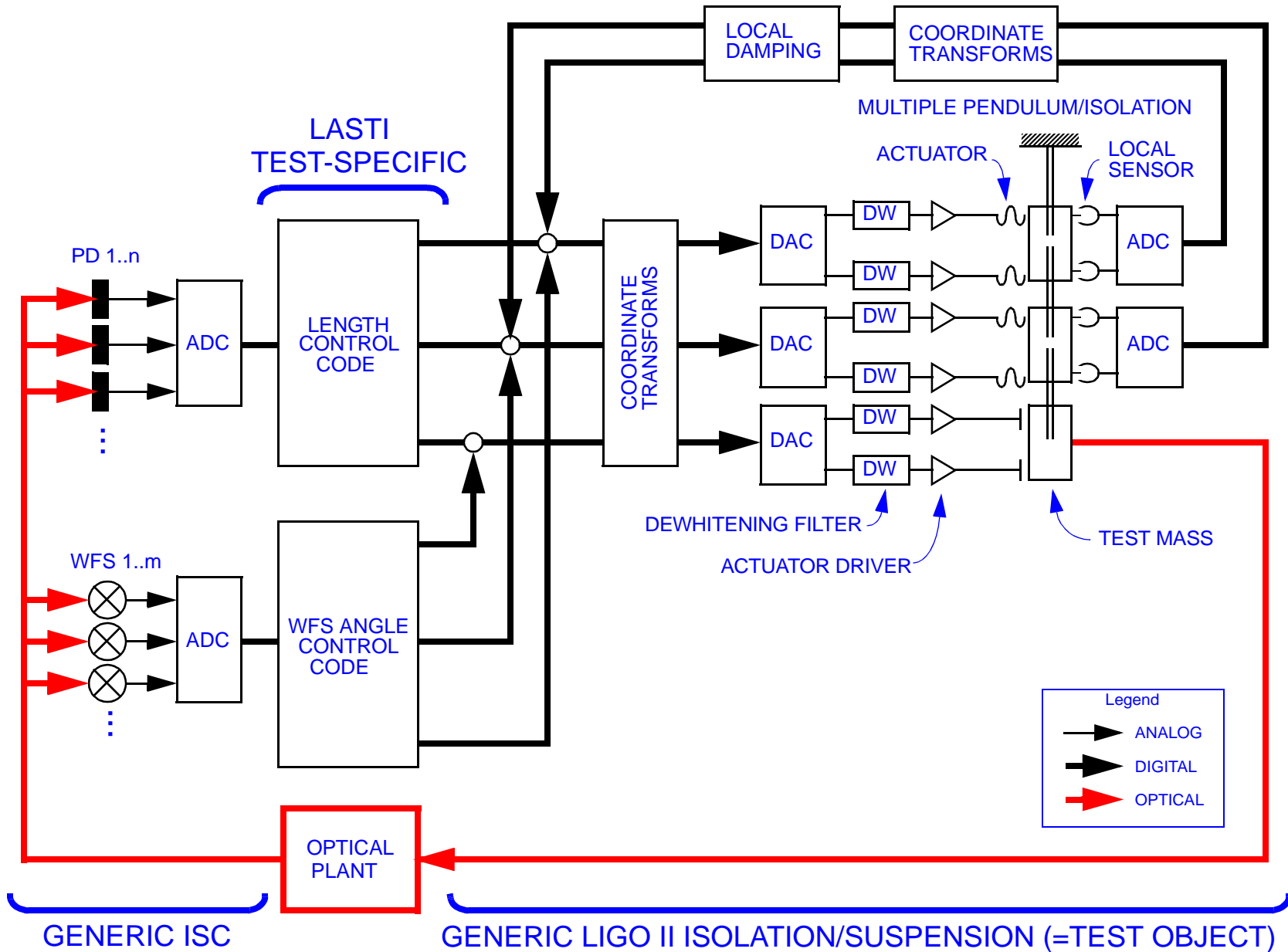

Schedule

- Dates as per White Paper; needs review/revision for near-term
- 4Qq99: LASTI envelope commissioned **DONE**
 - The vacuum envelope is installed and aligned; the vacuum pumping system is commissioned, and the system is pumped down for the first time.
- 1Q00: LASTI external structures installed **SEPT !5**
 - The seismic piers are erected around the HAMS and BSC. We wish to delay this milestone until a firmer baseline for the seismic isolation is established to avoid any backtracking.
- 2Q00: LASTI infrastructure design review **HERE AND NOW**
 - covers noise sources; models for the performance of the system; estimates for the optical sensing system, control and data, mechanical interfaces to LASTI; and the experimental program.

- 3Q01: LASTI infrastructure complete
 - sensing system, control and data,
and a trial cavity test of the complete system function
- 1Q02: HAM pathfinder installation complete, standalone testing starts
- 2Q02: MC controls SUS installation complete, testing starts
- 3Q02: BSC pathfinder installation complete, standalone testing starts
- 4Q02: TM controls SUS installation complete, testing starts
- 3Q03: LASTI controls test review
 - An understanding of the controls performance of the seismic isolation systems and of the suspensions
- 2Q04: LASTI noise prototype installed
 - The 'controls prototypes' for suspensions changed out and fused silica fiber, sapphire test mass Test Mass suspensions installed.
- 2Q05: LASTI final test review
 - This milestone should indicate the status of tests to meet the noise performance verification.



Schedule

- 3Q05: (maybe) LIGO II PSL/MC tests start, or
- 3Q05 LASTI first article installation starts
 - using the planned installation jigs and procedures, for seismic isolation and suspensions.

Personpower

- The success of this endeavor will require significant contributions from LSC members in and out of the Lab for success.
- presently a technician and bits and pieces of Zucker, Mason, and Shoemaker working on the vacuum system and experimental design.
- will ramp up this year to perform the design, procure and install the infrastructure; principally in-Lab personnel (at both MIT and Caltech, the latter for fabrication of PSL and CDS components).
- roughly 5-6 FTEs in the MIT Lab for the latter stages: 1 technician, 1 net FTE engineer, 2 students, 1-2 postdocs/scientists.
- need roughly again as many LSC Folk in moderate-term visits to MIT or thinking hard about the data and making frequent visits
- These manpower guesses do not include the staff associated with specific subsystems; there will clearly be constructive overlap in manpower.

The Last Slide (once again)

- clear that a significant test of the LIGO mechanical system can be performed
 - controls
 - performance - possible reduction in thermoelastic estimate TBD
- schedule workable, coordinated
- personpower requires strong collaborative effort, as for all of LIGO II

