

## Modal testing facility for Advanced LIGO

Caroline Cantley  
University of Glasgow  
Advanced LIGO SUS Workshop, Caltech, Oct 17 '03

LIGO-G030534-01-K  
Oct 28, 2003

- Experimental process of characterising the dynamic behaviour of a structure in terms of its modal properties (frequencies / mode shapes / damping factors)

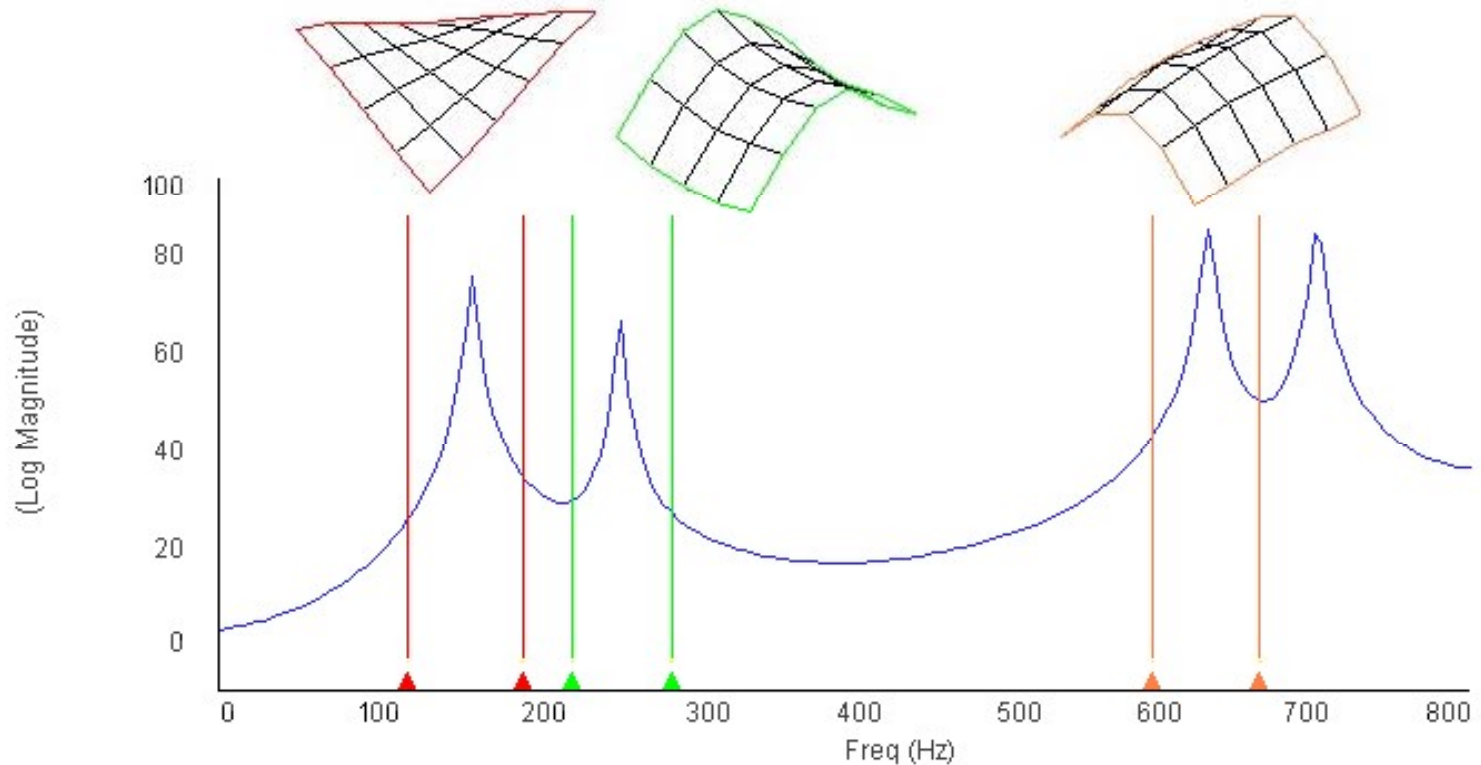

- **Modal analysis of structure**
  - Establish modal parameters (dynamic properties)
    - Natural frequencies
    - Mode shapes
    - Damping factors
- **Can be done by:**
  - **Theoretical FE analysis**
    - *Approximate* theoretical method
    - *Accuracy* always should be questioned
    - *Validation* is important consideration
  - or**
  - **Experimental modal analysis**
    - *Accurate* since based on *measured* not predicted behaviour
    - Design/troubleshooting tool
    - Validation tool for FE
    - restriction - the physical structure must exist
  - or**
  - **Both (complementary tools)**

Design stage FE analysis → manufacture prototype → experimental modal analysis → modal model → verification or structural modification within modal model → structural modification of prototype → FINAL STRUCTURE

- 5 main steps:
  - (1) MODEL – creation of the structure
    - Points, lines and surfaces used to define the shape of an object
  - (2) MEASUREMENTS - acquire the data
    - Driving point DOF (may be more than one)
    - Response (3 DOF multi-point)
  - (3) ANALYSIS - analyse the data
    - Frequency , identify peaks and curve fit, FRF synthesis

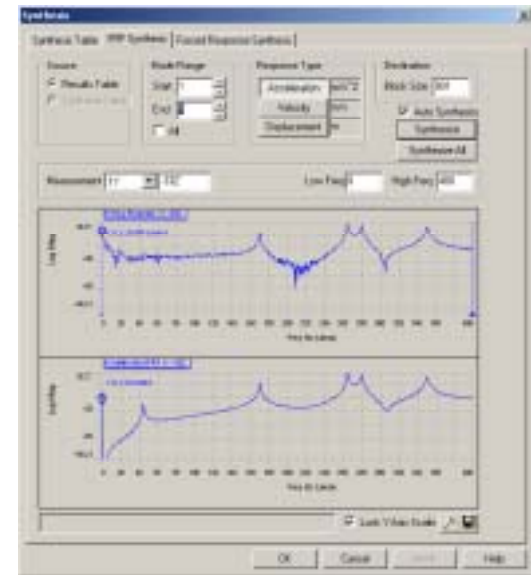
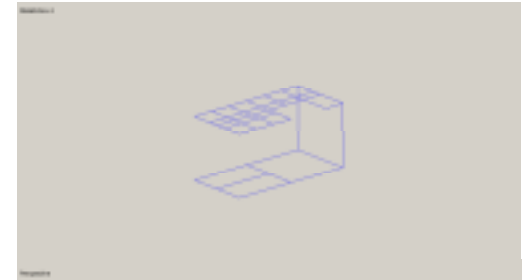

- (4) RESULTS – synthesis of mode shapes  
time domain animation



- (5) MODIFICATIONS – modify the structure
  - To simulate the effects of a structural modification
    - Mass, stiffness, damping

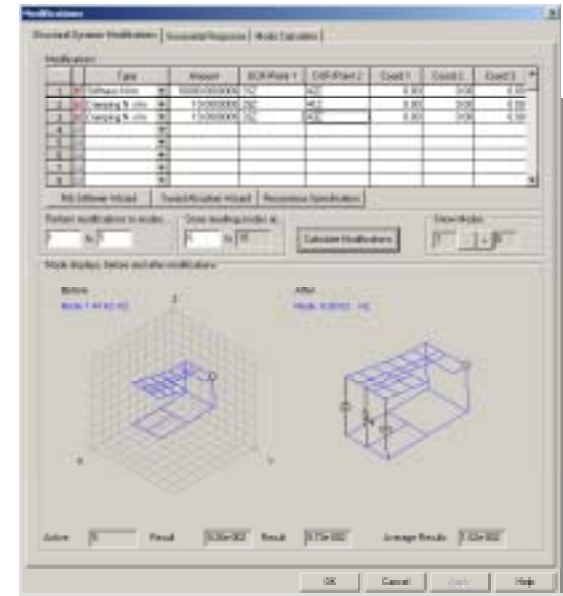

- Suspension design:
  - 1) Support structures (1<sup>st</sup> mode <150Hz?)
  - 2) Cantilever blades (internal modes)
  - 3) Other substructures e.g. tablecloth modes
- Other:
  - 1) Optics table
  - 2) Silica/sapphire mirror substrates (thermal noise predictions)
  - 3) Silica fibres/ribbons

- Source suitable equipment for proposed 'Modal Testing Facility' for Advanced LIGO
- Three equipment functions to consider in the process of modal testing:
  - Excitation method
  - Response measurement method
  - Data acquisition & analysis software

<i>Applications</i>	<i>Requirements</i>				<b>Data Acquisition &amp; Analysis Software</b>
	<b>Excitation Method</b>		<b>Response Measurement Method</b>		
	CONTACT (shaker or impact hammer)	NON-CONTACT (acoustic or electrostatic)	CONTACT (accelerometers)	NON-CONTACT (laser vibrometer)	
<b>Suspension support structures</b>	●		●	●	<b>Rule of thumb – don't overspecify</b>
<b>Cantilever blades</b>	●		(●)	●	
<b>Mirror substrates</b>		●		●	
<b>Silica ribbons/fibres</b>		●		●	



- Mechanical shaker
  - White noise
    - wide range of frequencies
  - Sinusoidal testing
    - sweep through frequency until hit resonance – test at this frequency
- Impact hammer
  - Impulse response
    - frequency range depends on properties of hammer tip so choose the tip for the application
      - hard tip (high frequency modes)
      - soft tip (low frequency modes)

- Electrostatic
  - Swept sine
    - Currently used to locate modes on mirror substrates and then perform Q measurements (ringdown)
  - White noise
- Acoustic
  - White noise
    - would work for ribbon/fibre excitation (limited to measurements in air only)

- **Impact Hammers**

- PCB Impact Hammers by Techni measure
- instrumented hammers for measuring the force input during modal impact testing. Kits which include power supplies, two accelerometers and cabling, are also supplied.
- General purpose hammer kit £2.5K
- Sledge hammer kit £3.5K

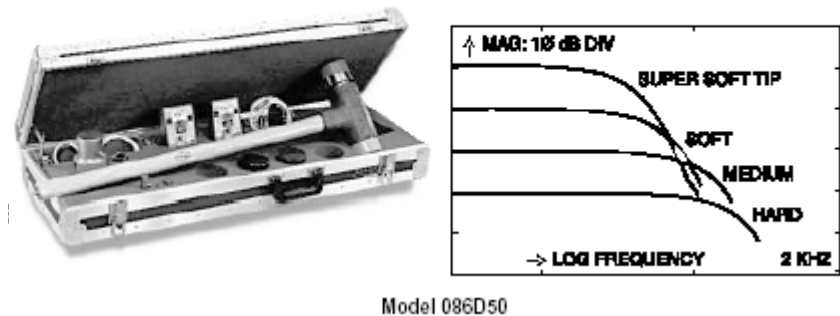
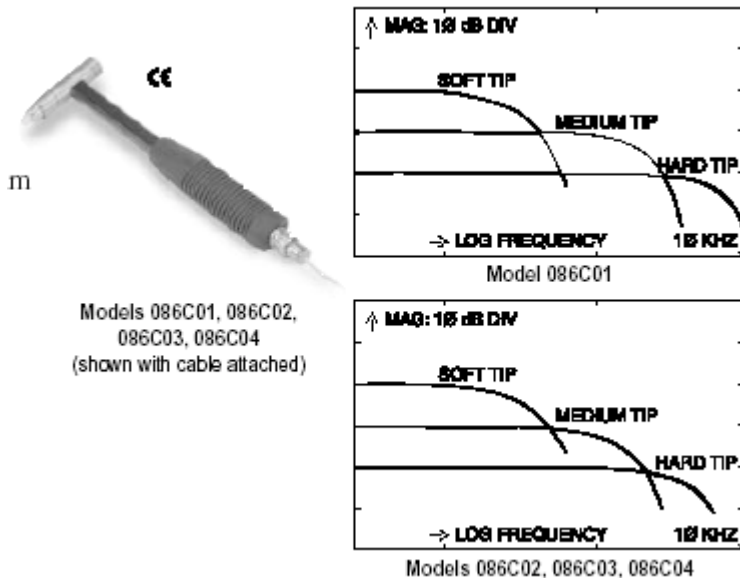

- Accelerometers (contact)
  - Two main types
    - (Capactive – simple battery hookup – static acceleration measurement)
    - Piezoelectric – ICP charge output (integrated circuit piezoelectric) with built-in signal conditioning
      - e.g. ICP structural test / array accelerometers (PCB 333 series)
      - Lightweight for multi-point modal and structural testing
- Laser systems (non-contact)
  - Laser vibrometer – Doppler effect
    - 1D - basic
    - 3D – measures shear from perpendicular offset
    - Scanning – precision applications
    - Lambda Photometric (Polytec)

- 1D general purpose use ~ £28K
- 3D contains 3 independent laser Doppler sensors in one common optical head ~ £32K



- Data acquisition
  - Dual channel (~£15K)
    - Larson Davis FFT analyser
  - Multi-channel (x few £10K's)
    - Zonic data acquisition system
- Data analysis software
  - STAR6 modal - simple, PC basec user friendly (<£11K)
  - IDEAS – advanced (x few £10K's)
  - LMS -advanced (x few £10K's)

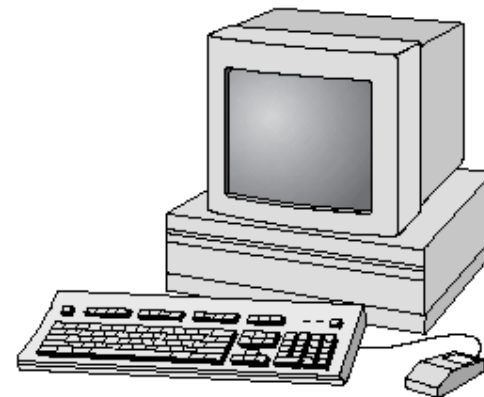

Data  
Acquisition  
or  
Modal Analysis  
Workstation

- Testing time is not a major consideration. Facility required intermittently.
- OPTION '1'
  - Impact hammer kit. ICP accelerometers with dual channel Larson Davis. STAR6 modal analysis software mounted on available PC (~£23K to ~£31K depending on STAR6 edition)
- OPTION '2'
  - Impact hammer kit. Dual channel Larson Davis with 1D laser vibrometer with STAR6 modal on available PC (~£49K to ~£57K depending on STAR6 edition).
- Laser vibrometer modal tests will be starting soon at Glasgow.

- Feedback from this discussion
- Detailed prices
- Final recommendations to follow