

SEI Technical Status – NSF Review 2011

G1100447-v3

April 26, 2011

Fabrice Matchard for the SEI Team

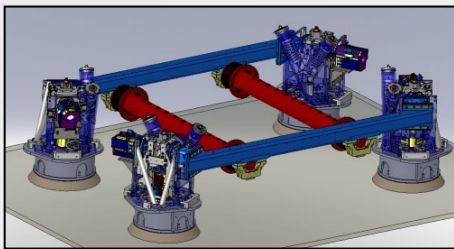

▪ HAM-HEPI



▪ HAM-ISI

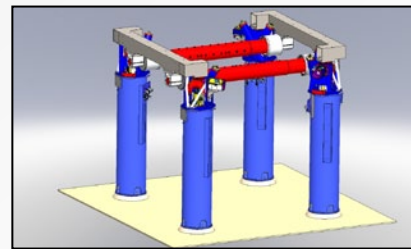

▪ BSC-HEPI

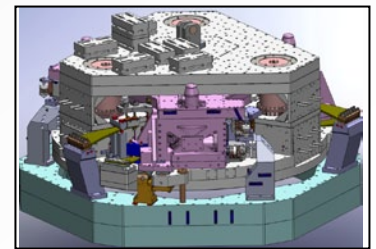

▪ BSC-ISI

- Provide quiet, well controlled platform for the optics in 6 DOF.
- Provide low-frequency, large-throw positioning of the optics.
- From Initial LIGO/Enhanced LIGO to Advanced LIGO

\$38.3 M

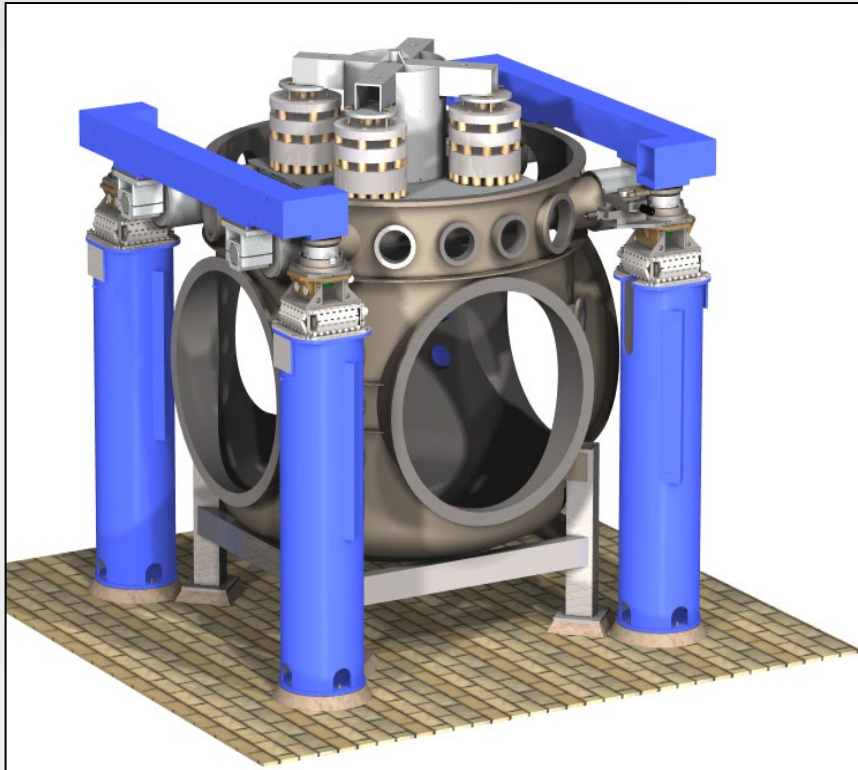

▪ Initial LIGO – BSC Chambers Equipment

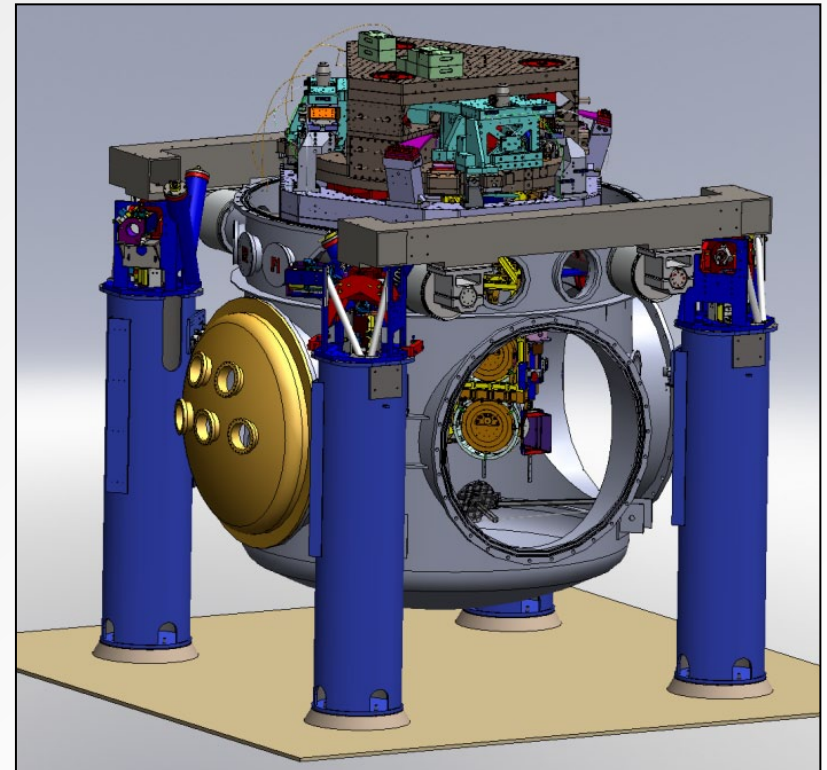

▪ Advanced LIGO – BSC Chambers Equipment

- Small Test Mass Motions: needs for high performance seismic isolation

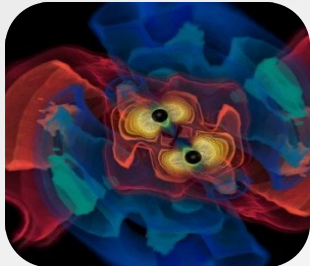
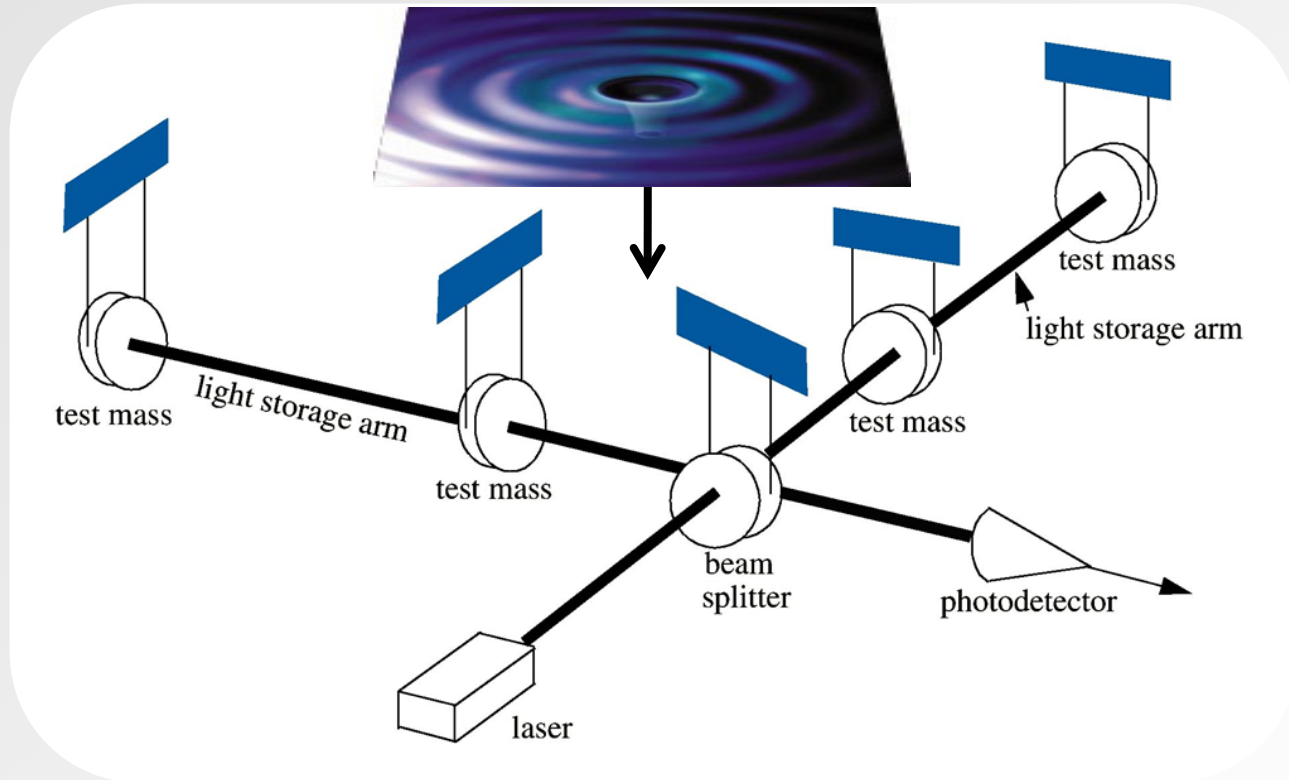

$$M \approx 10^{30} \text{ kg}$$

$$R \approx 20 \text{ km}$$

$$f \approx 400 \text{ Hz}$$

$$r \approx 10^{23} \text{ m}$$



$$h \sim 10^{-21}$$



Noise Isolation:

- Seismic
- Thermal
- Shot



LIGO Livingston System Layout

Livingston, Louisiana

Y End Station

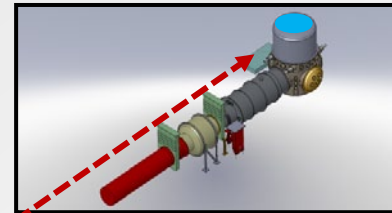

4 Km Y Arm

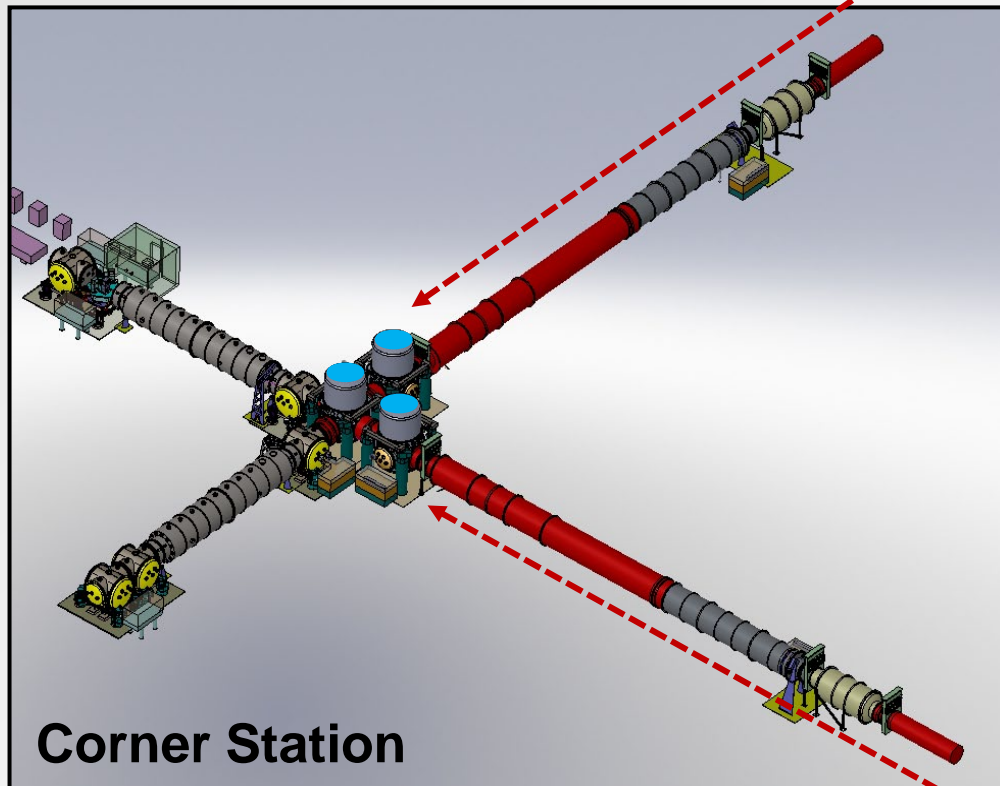

Corner Station

4 Km X Arm

X End Station

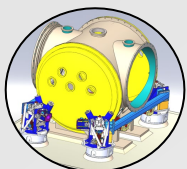
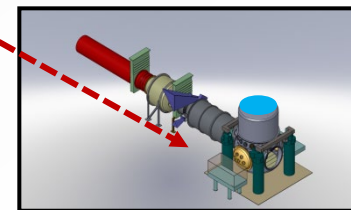

Auxiliary Optics
(5 + 1 Chambers)

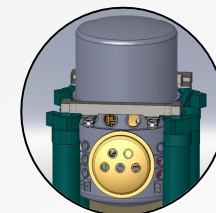
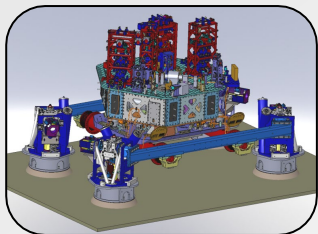

Core Optics
(5 Chambers)

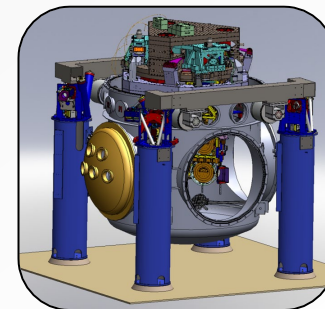

Optical Layout

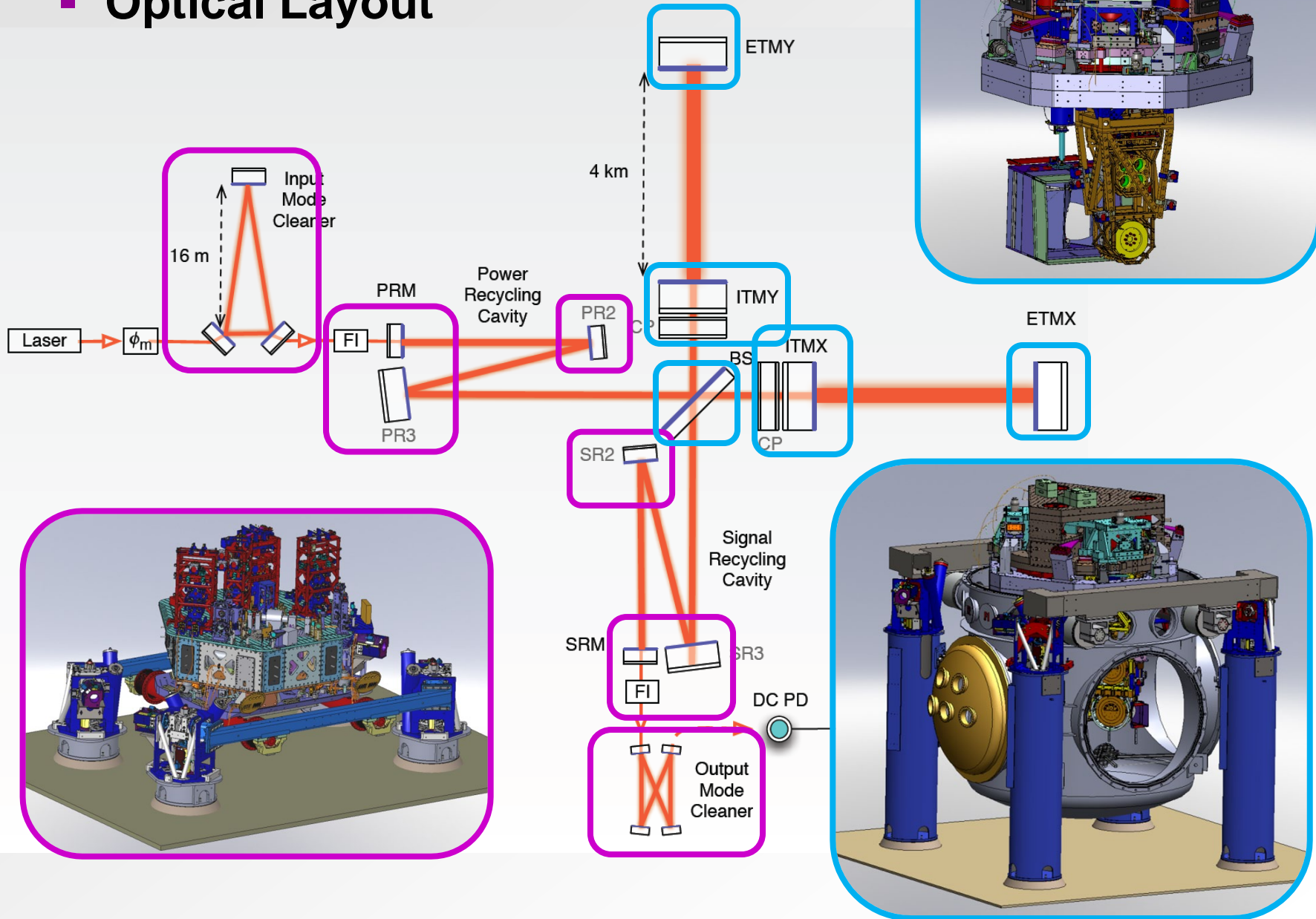



LIGO Hanford System Layout (H1 and H2)

Y End Station

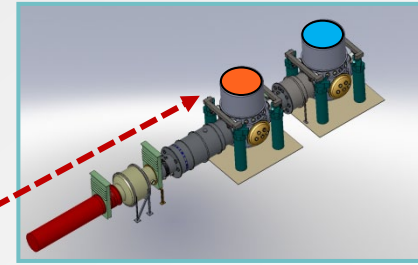

4 Km Y Arm

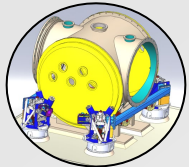
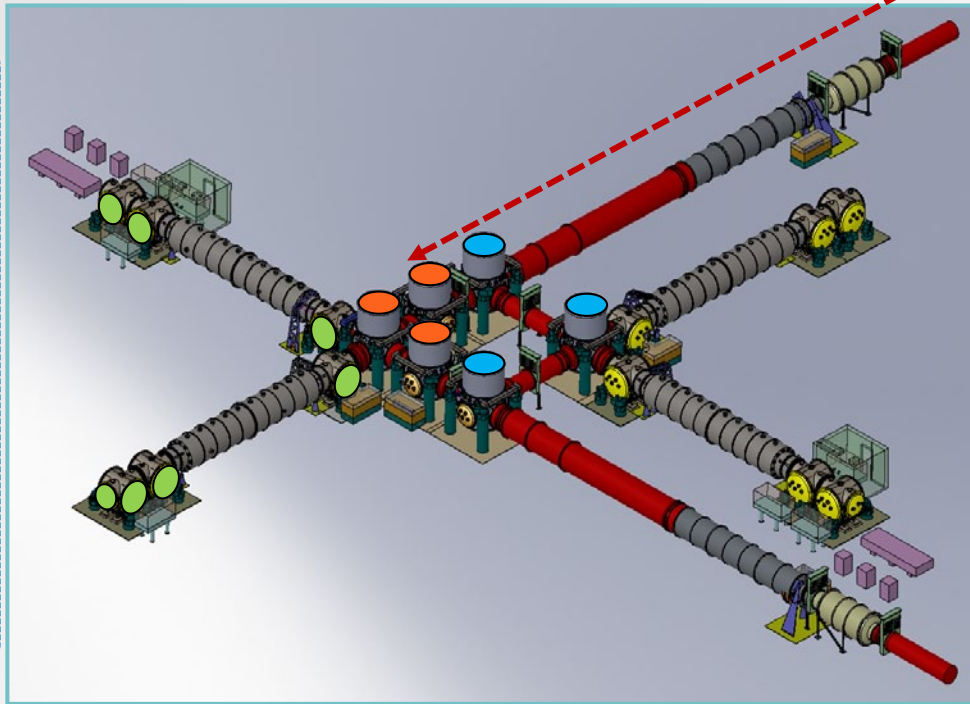

Support Auxiliary Optics (10+2 Chambers)

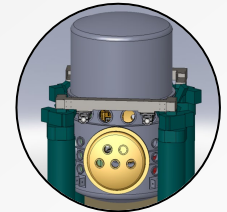
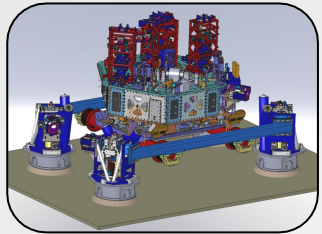

Support Core Optics (10 Chambers)

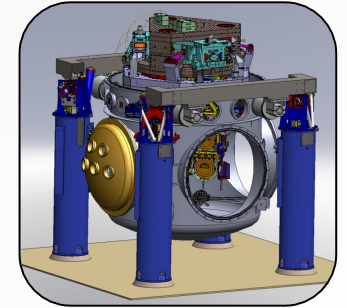

- 6 HAM Chambers for H1
- 5 BSC Chambers for H1
- 6 HAM Chambers for H2
- 5 BSC Chambers for H2

X End Station

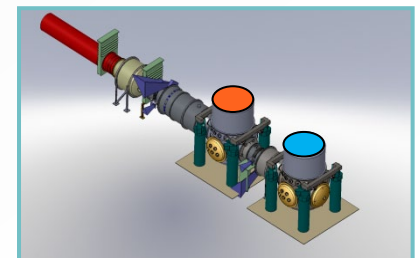

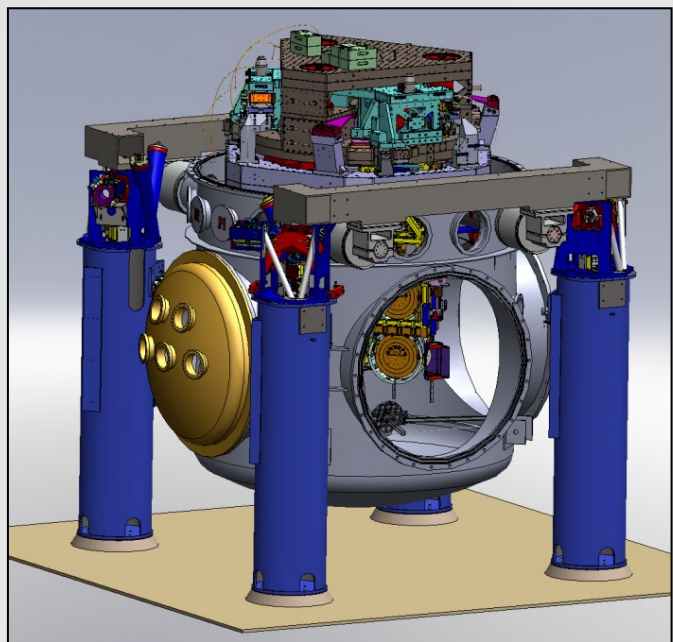

Up to 7 Stages of Isolation in Series

- HEPI (1) - SEI subsystem
Pre-Isolator
Low frequency positioning
Isolation from 0.1 to ~5 Hz
- BSC-ISI (2) - SEI subsystem
Internal Seismic Isolation
Isolates above ~0.2 Hz
Quiet, well controlled table
- Quad pendulum (up to 4) – SUS
- Req: 10^{-19} m/ $\sqrt{\text{Hz}}$ at 10 Hz

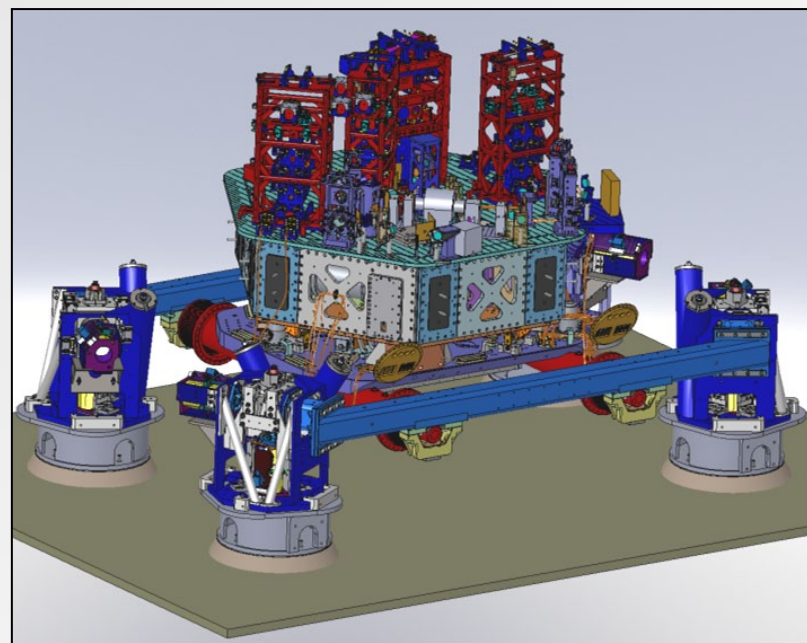

Up to 5 Stages of Isolation in Series

- HEPI (1) - SEI subsystem
Pre-Isolator
Low frequency positioning
Isolation from 0.1 to ~5 Hz
- BSC-ISI (1) - SEI subsystem
Internal Seismic Isolation
Isolates above ~0.2 Hz
Quiet, well controlled table
- Triple pendulum (up to 3) – SUS
- Req: 10^{-17} m/ $\sqrt{\text{Hz}}$ at 10 Hz

- Seismic Isolation Group responsibility:

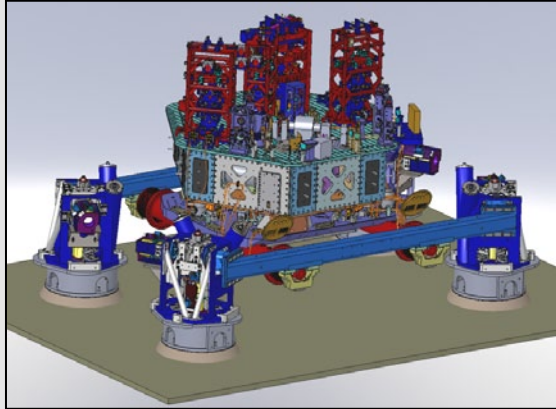

HAM Chambers Equipment

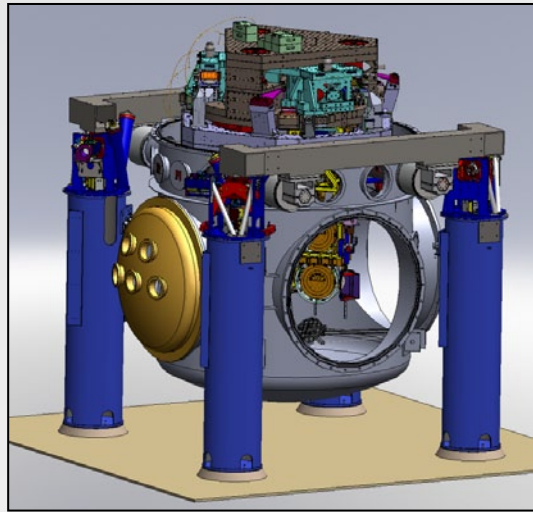

BSC Chambers Equipment

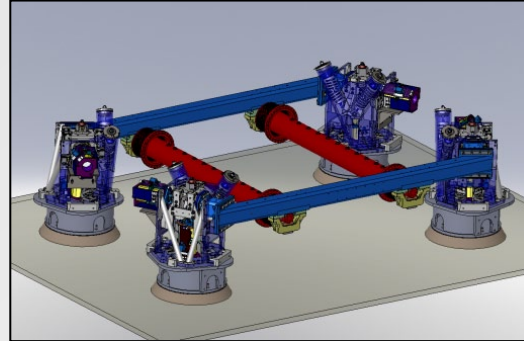

HAM-HEPI:
Hydraulic External Pre Isolator

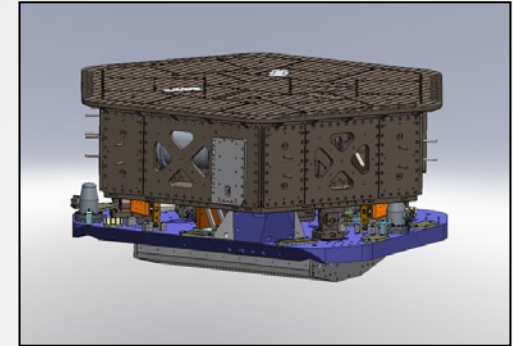

HAM-ISI:
Single Stage
Internal Seismic Isolator

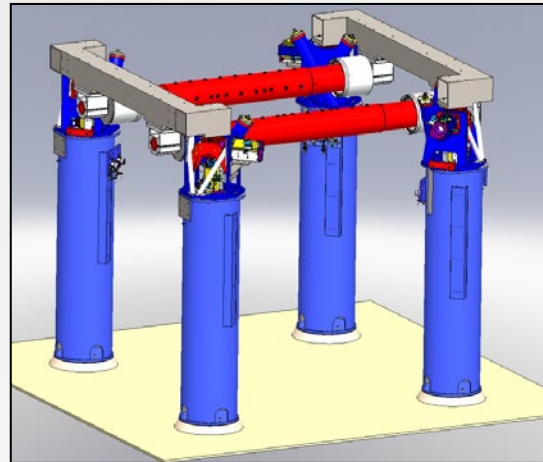

BSC-HEPI:
Hydraulic External Pre Isolator

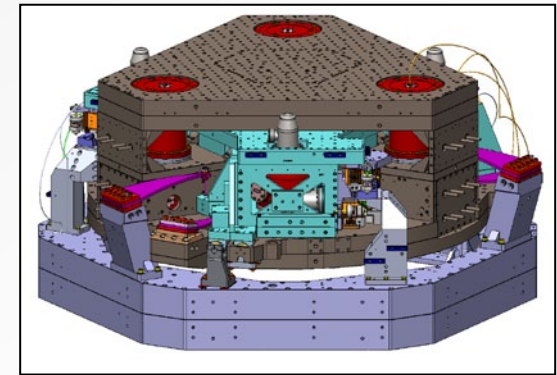

BSC-ISI:
Two-Stage Internal Seismic Isolator

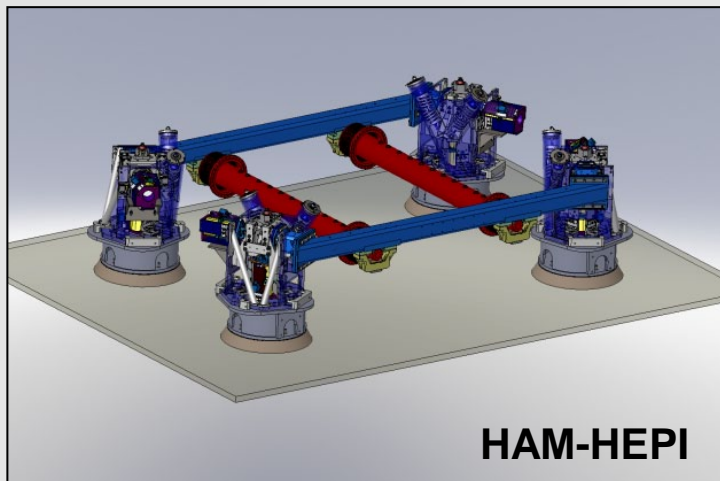

□ 2.1 Overview

□ 2.2 Pre-Assembly Testing

□ 2.3 Assembly

□ 2.4 Performance

April 2010 – April 2011
HEPI Progress Highlights

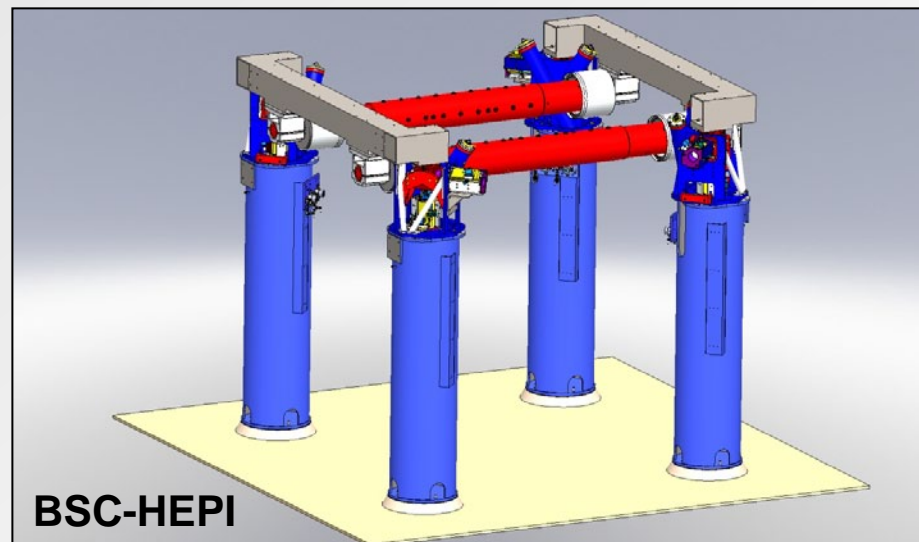

HEPI OVERVIEW:

- Pre-Isolator, Out of Vacuum
- Minimize heat dissipation in-vacuum
- 6 Degrees of freedom
- Positioning and alignment, length and angle
- Low Frequency active isolation (0.1 Hz to ~5 Hz)
- Micro Seismic, Tidal Correction
- Was used for iLIGO and eLIGO at LLO
- Will be used on all chambers (18 HAM and 15 BSC).
- HAM Cross beams re-designed
- LLO HAM will become LHO BSC

- Installed at LLO for Initial LIGO. Running for many years. Intended for Advanced LIGO, but installed to remediate large ground motion at first 2 stack modes.
- LLO gets new electronics and new HAM units. LHO gets full installation.
- All HAM crossbeams will be upgraded.
- Recent performance improvements from optimal feedforward filtering based on interferometer signals.
- A few of the new actuators may need to be rebuilt, tests underway on those at Stanford.
- Many components of LHO system now assembled as modules, actuators being tested, installation and plumbing begins in early 2011.

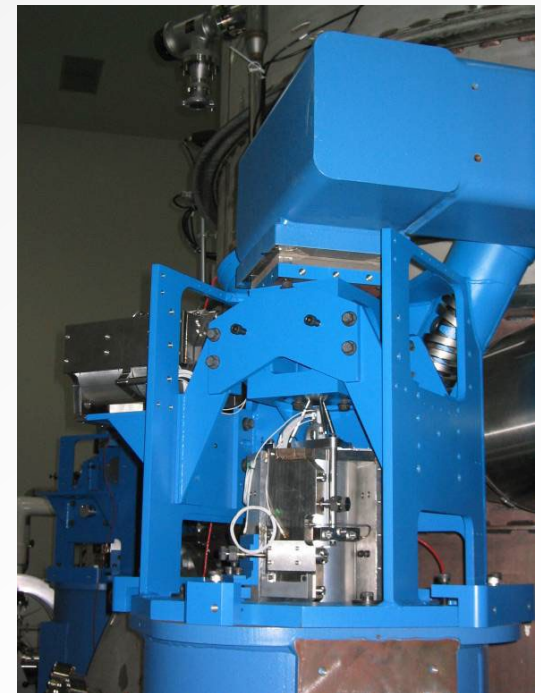
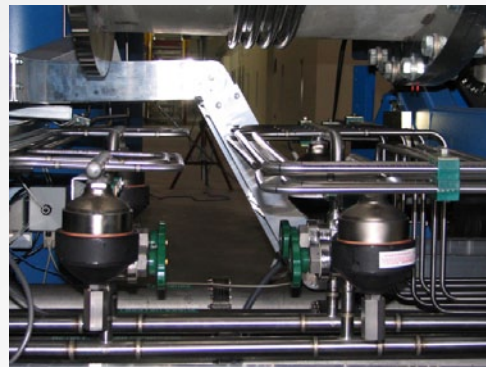
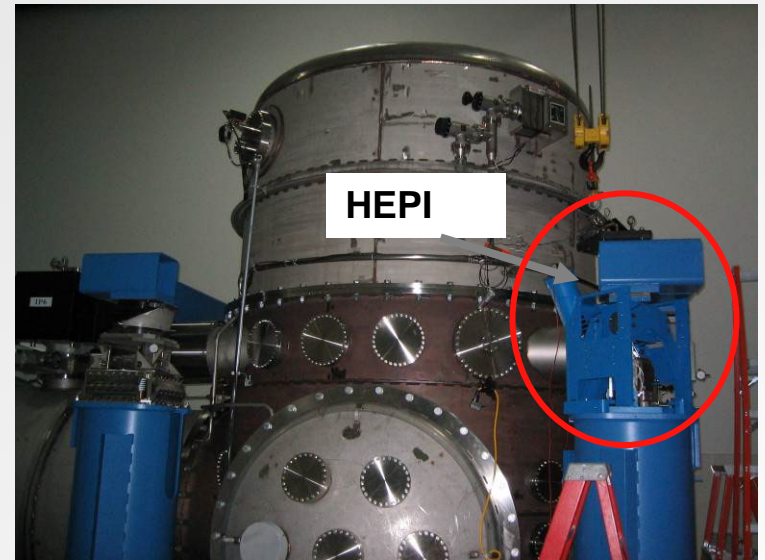

2. HEPI (Hydraulic Pre-Isolator)

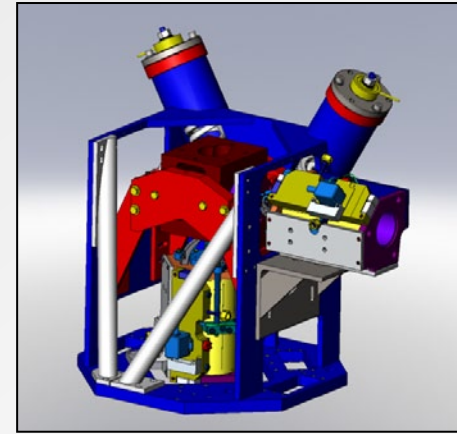
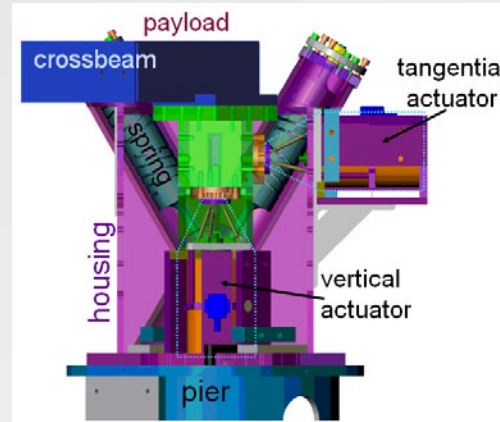
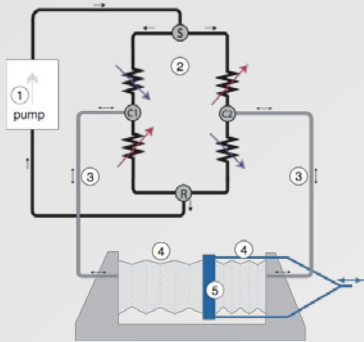
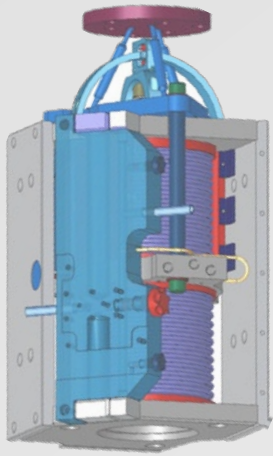

More range than PZTs (+/- 1 mm)

More force than voice coils (~400 lbs, static offset)

Quiet (<1 nm/√Hz at 1 Hz)

HEPI housing on pier top holds:

Actuators and sensors for vertical and tangential directions

Offload springs & payload adjustment

Caging, stops, alignment features...

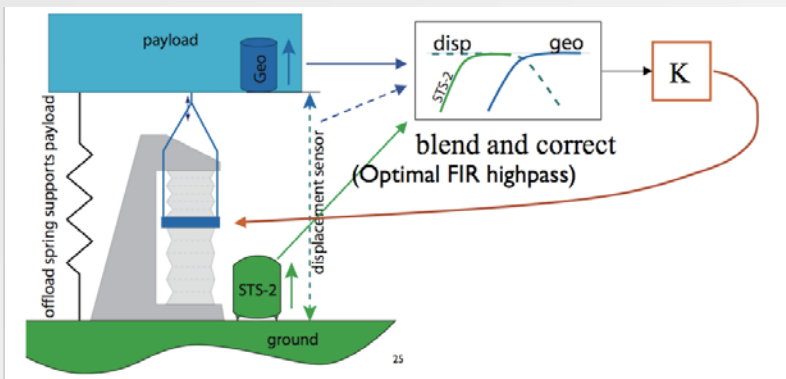

Low frequency control topology

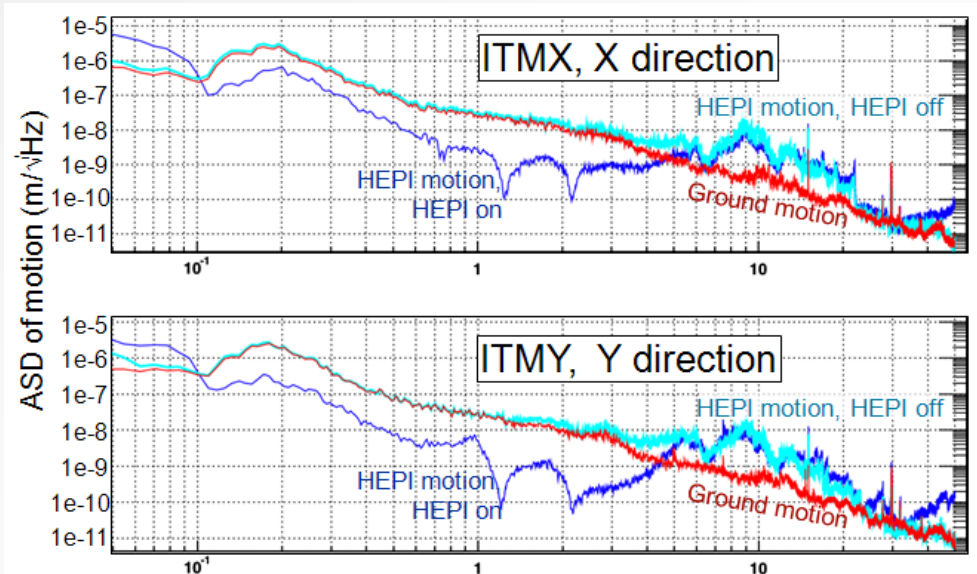

data from Shyand Wen, March 2006, SEI loq entry 604

HEPI performance at LLO

- ❑ Sensors: done (presented last year)
- ❑ Actuators:

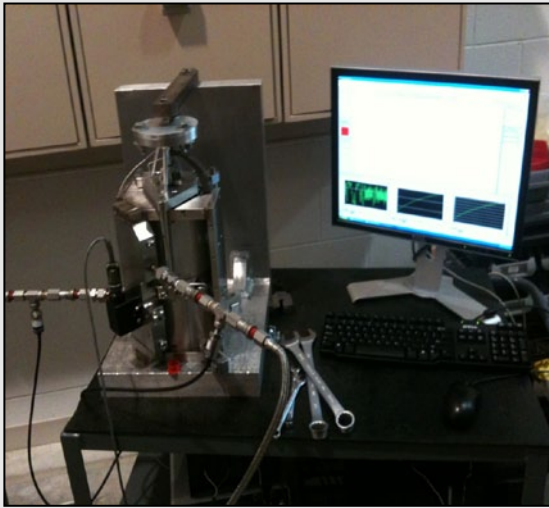

Test Stand Set-Up

- Actuator attached to a calibrated force load cell.
- Capacitive displacement sensors mounted to monitor displacement. Typical maximum response range is from +/- 1.3mm.
- Actuators driven through a range of currents to the Parker valves that control the pressure differential of the HEPI fluid.
- The linear relationship of this drive current to displacement response is desired for at least 2 mm of displacement.

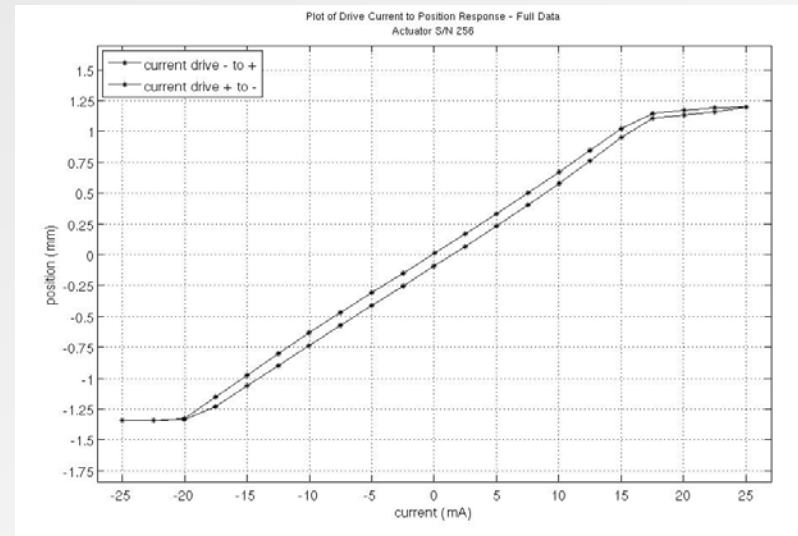

Test Results

- Linearity is confirmed for an actuation range of +/- 1mm.
- Specification calls for +/- 1mm of linear actuation and response.
- Maximum displacement is typically +/- 1.3mm, with none less than +/-1.1m
- So far, 125 of the 144 HEPI actuators needed at LHO show a good linear response for at least 2mm of displacement.
- Only 2 thus far display a slight non-linearity through a limited actuation range.

LHO - BSC HEPI Assembly Support:



- HEPI Support Structure



- HEPI Support Insertion



- HEPI Actuators



- Actuators Installation

LLO - HAM 2 HEPI Assembly Support:

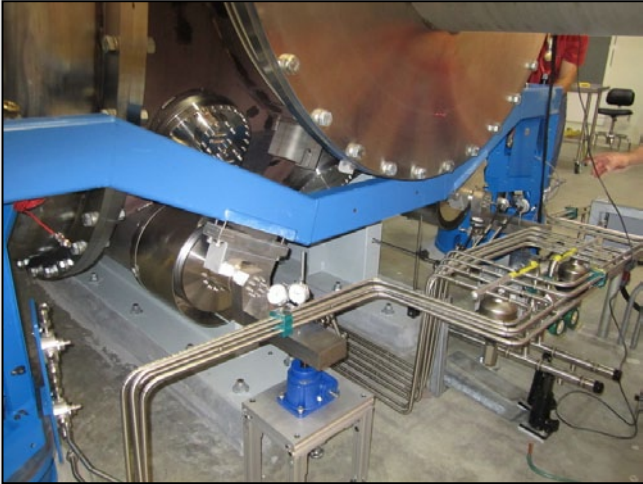

- Old Cross Beams



- New Cross Beams

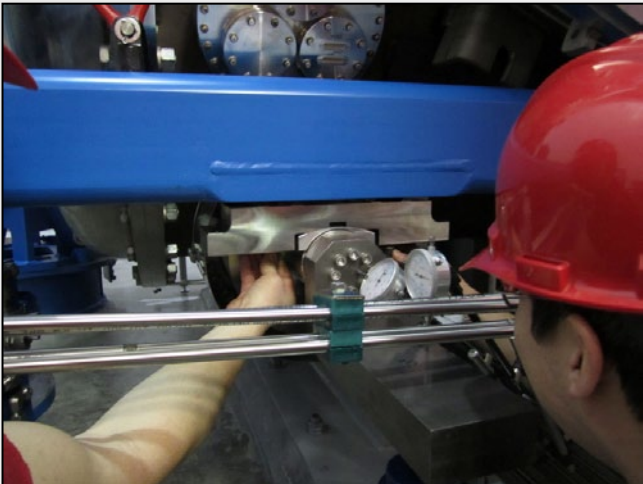

- Clamps Adjustments



- Advanced LIGO HAM 2

Example of control enhancements using HEPI

Feedforward controller From HEPI to BSC-ISI
Stage 1 Motion Z axis - 15 April 2011

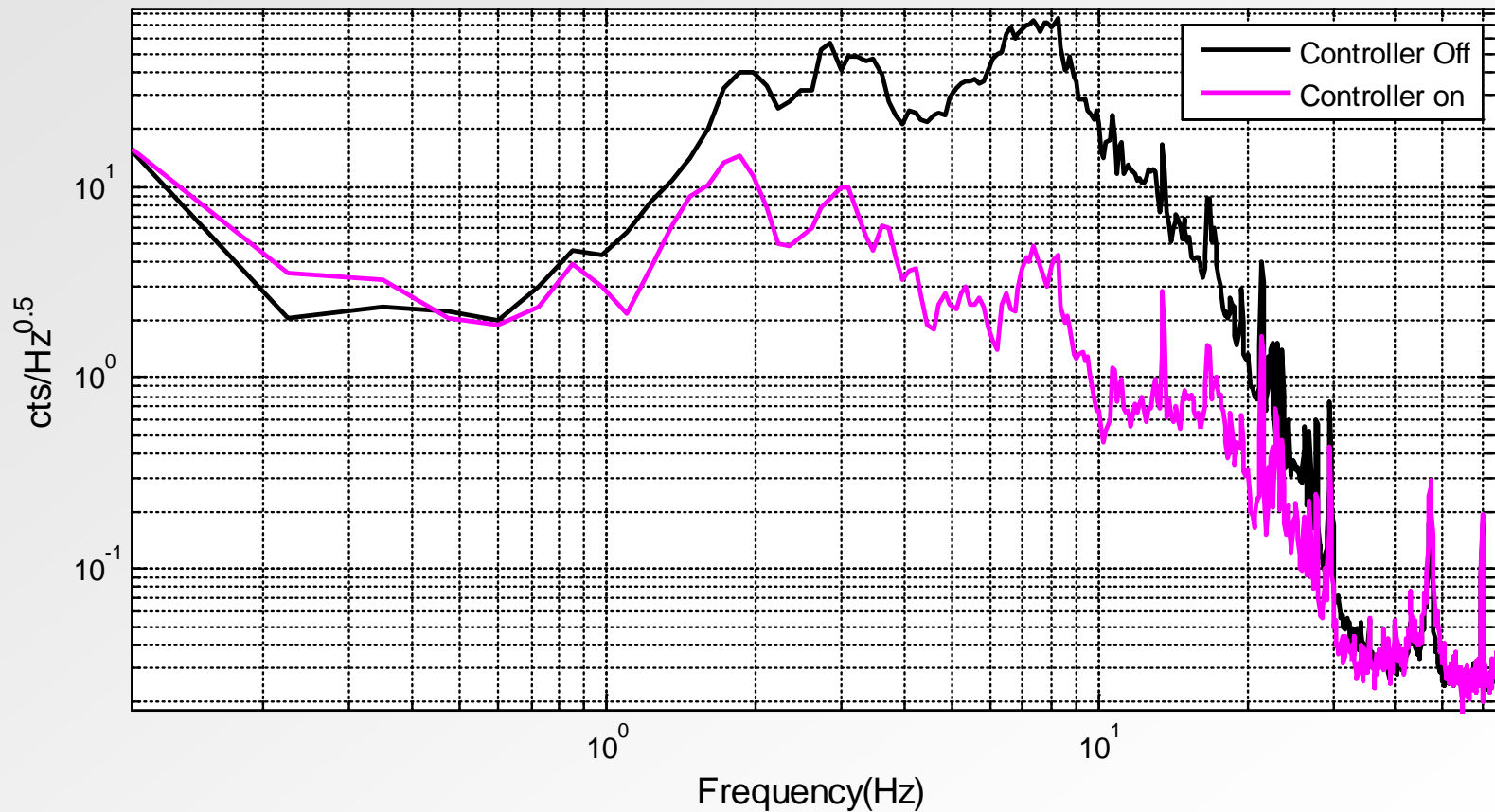

HAM-ISI Overview:

- Single-Stage Isolator
- Internal (In Vacuum)
- 6 Degrees of freedom
- Positioning and alignment
- Active isolation (0.1 Hz to ~25 Hz)
- Passive Isolation ($1/f^2$ from a few Hz to ~100Hz)
- Used in HAM6 at LLO and LHO to supports the OMC
- Will be used in all of the 15 HAM chambers
- 6 Already assembled and tested
- Defects un walls
- Back on pace

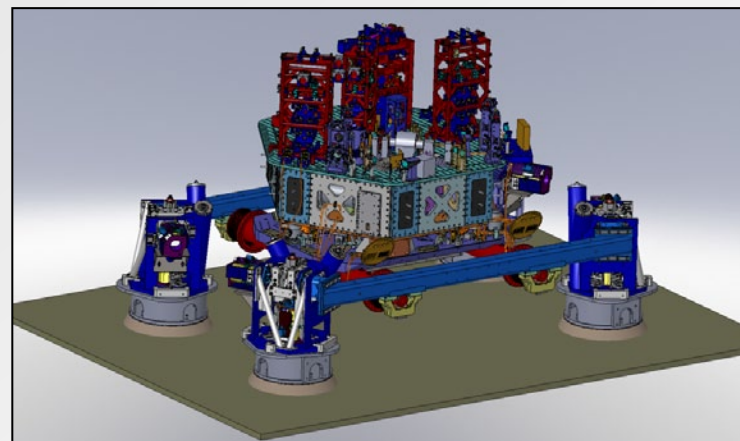

- HAM-ISI on HEPI and Supporting Triple Suspensions (HAM 2)

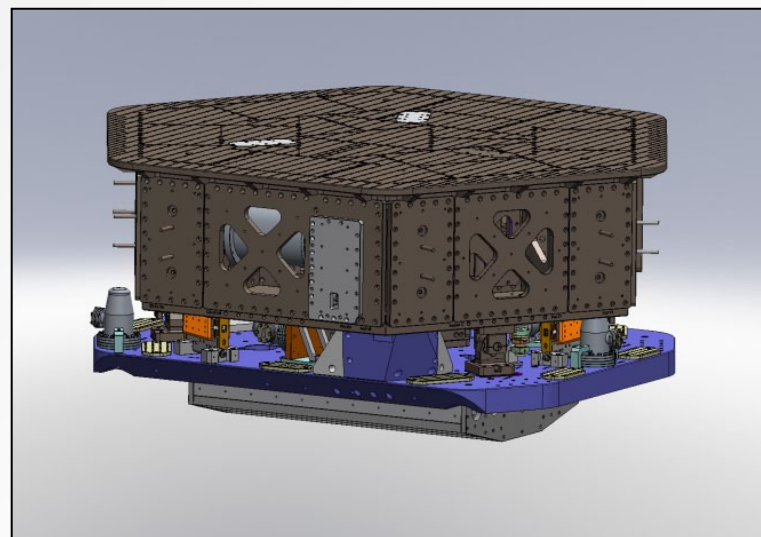

- HAM-ISI Stage 0 (blue) supporting Stage 1 (brown)

- HAM-ISI Architecture:

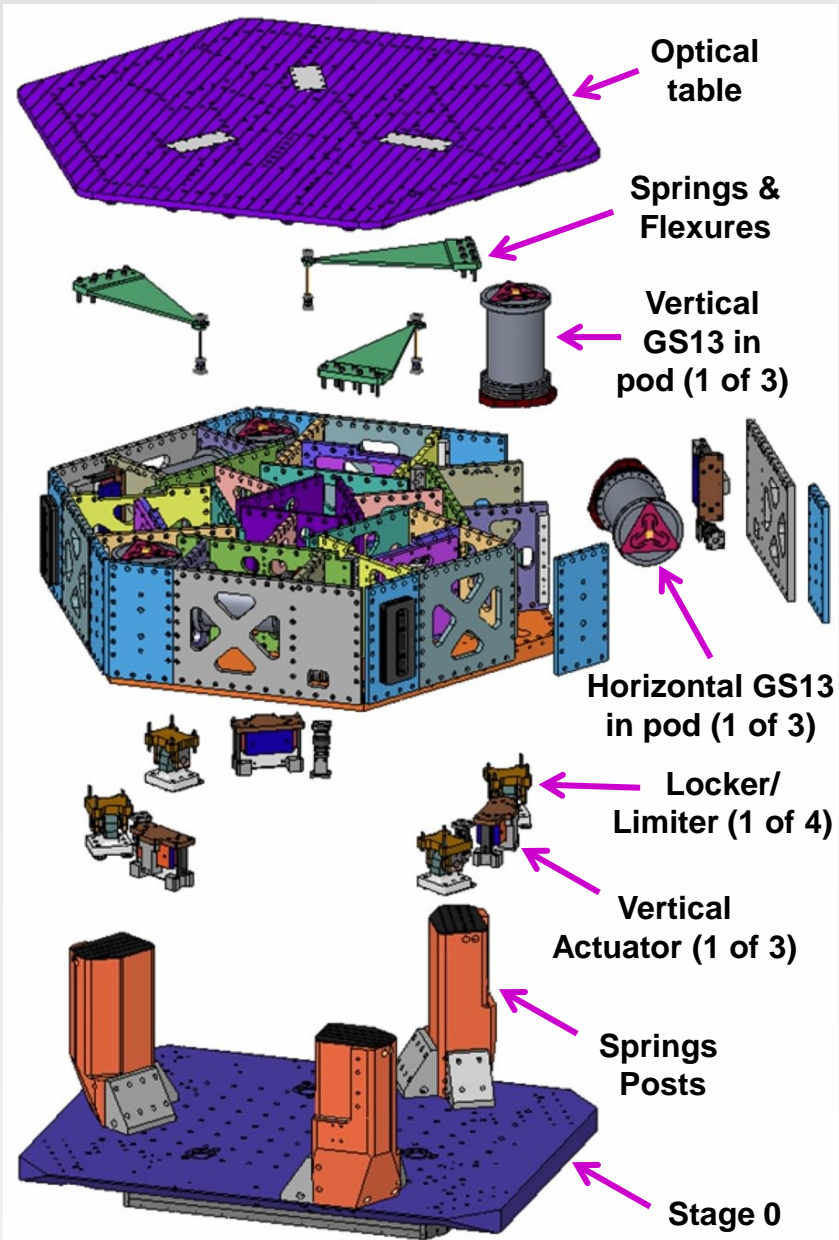

- Springs and sensors under the optical table:

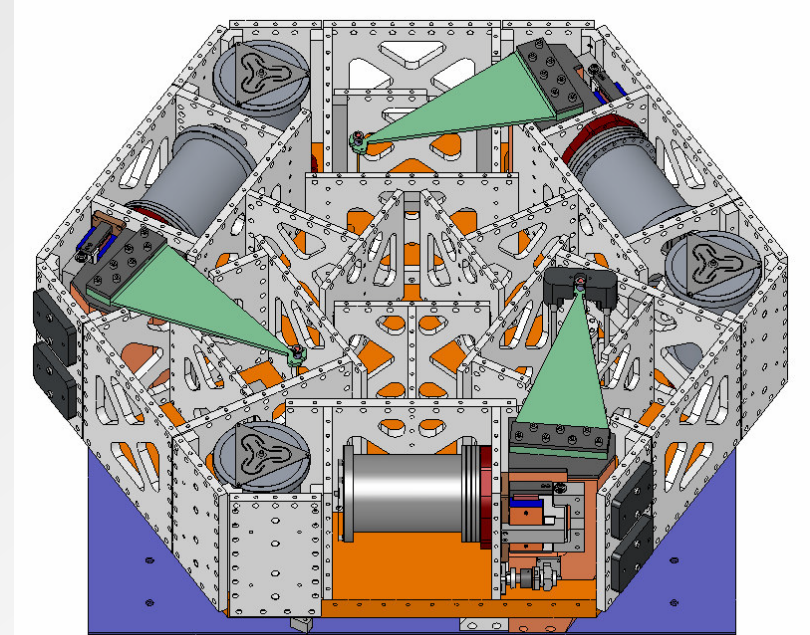

- Access to a vertical sensor:

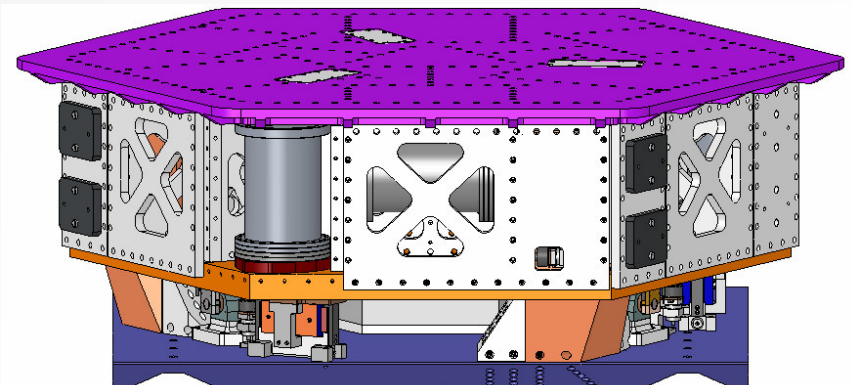

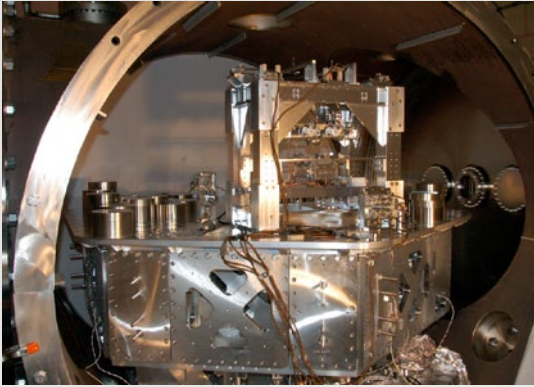

- Enhanced LIGO HAM6 Installation



- OMC on HAM-ISI in HAM 6

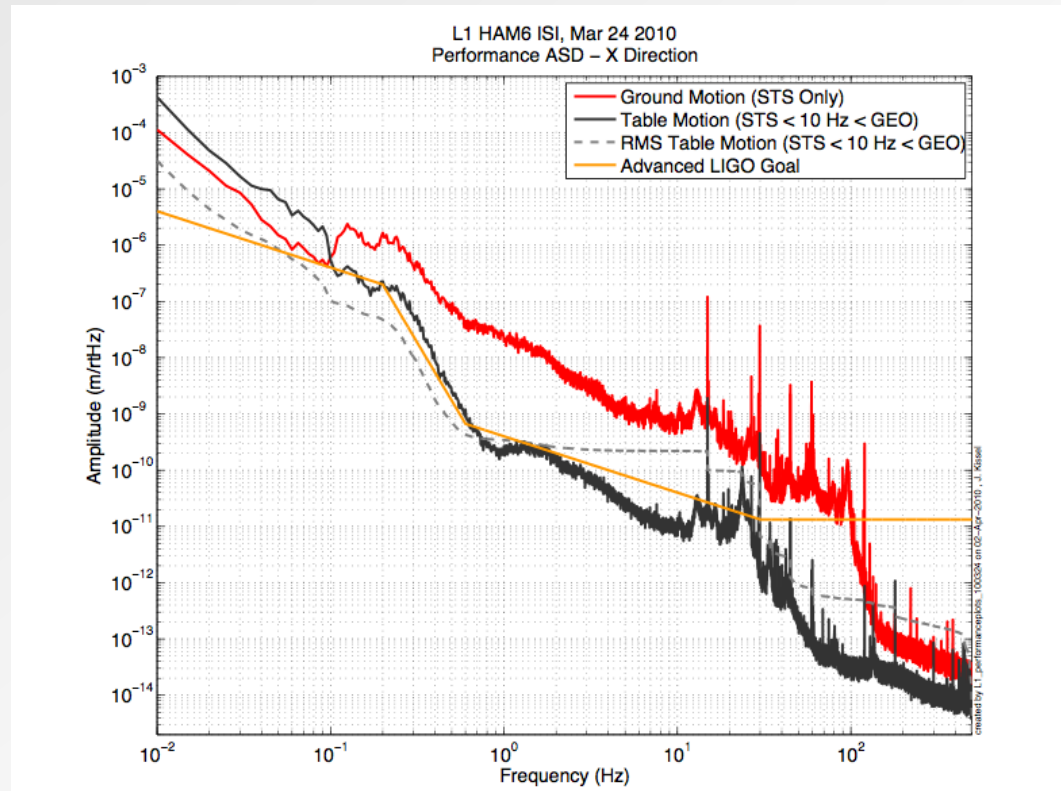

- HAM ISI Performance, X

April 2010 – April 2011

HAM-ISI Progress Highlights

- 3.1 Procurement, Clean & Bake**
- 3.2 Assembly**
- 3.2 Testing**

Facility Modifications and Preparation (FMP)

LLO:

- 3 Vacuum Bake Ovens
- 1 large Air Bake Oven

LHO:

- 3 Vacuum Bake Ovens
- 1 large Air Bake Oven



- Vacuum Prep Warehouse Drying Station



- Vacuum Bake Oven



- Clean Parts ready for HAM-ISI assembly

- **Helicoils Inserts**



- **Pitch Forks Assembly**



- **Blades Posts on Stage 0:**



- **Top view of the Blades Assembly:**

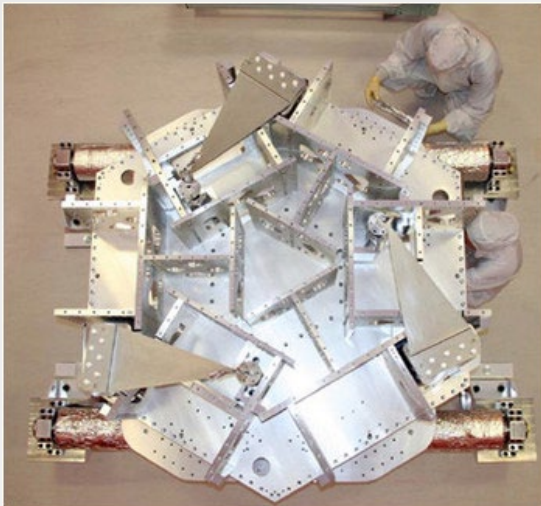

- **Seismometers and Actuators:**



- **Capacitive Position Sensors:**



- Storage Containers Prep



- HAM-ISI Lift



- Storage Containers Closing



- Transport



Parts repairs:

- Welded plugs
- Risk of out gassing
- No accurate list or records
- Intensive investigation
- X-Rays Inspection
- Vacuum review board: no risk may be taken
- Procurement of new plates
- Back to assembly
- Statement of work, drawings updated
- More details in G1100463 QAME presentation

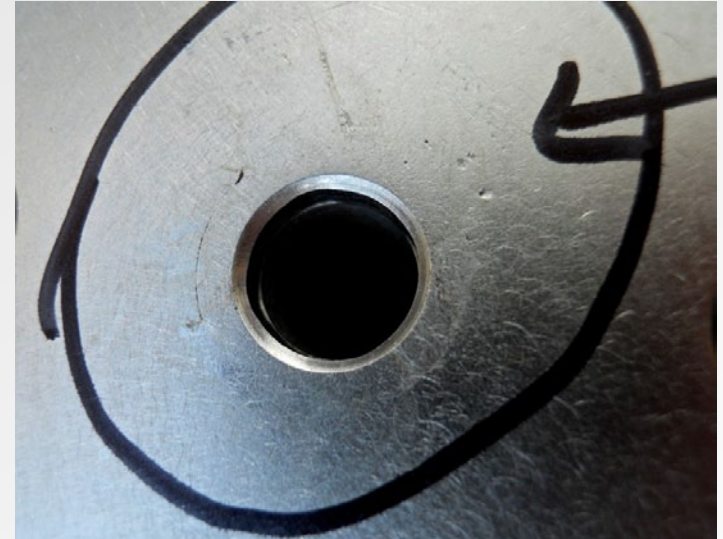
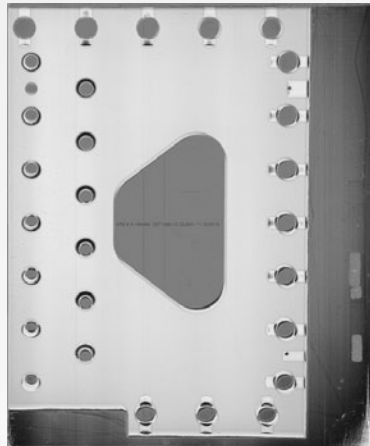
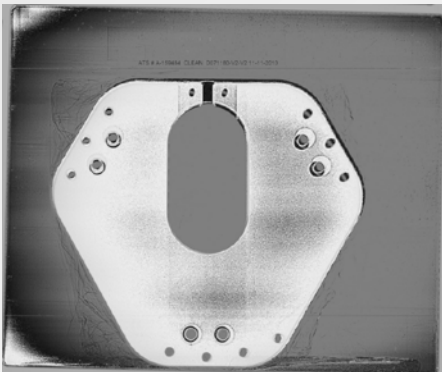

- LLO HAM-ISI Unit #3 re-assembled on 03/10/11

Seismometer Pods Leak Testing

Helium Leak Test

- At NorCal
- Before cleaning
- Max Leak Rate: 1×10^{-9} Torr L.s-1

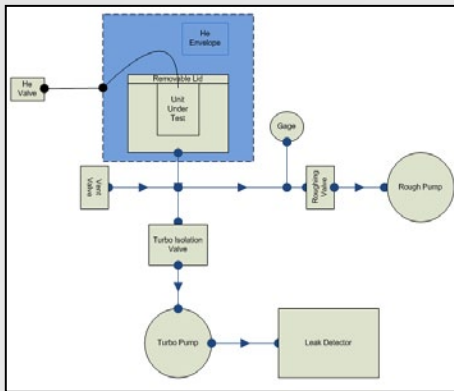

- Helium Leak Test System

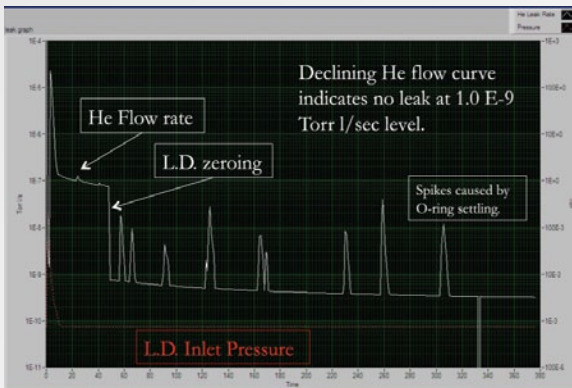

- VPW Drying Station

Neon Leak Test

- At LLO
- After cleaning & assembly
- Max Leak Rate: 1×10^{-9} Torr L.s-1

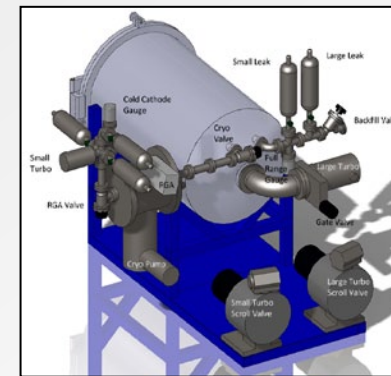

- Neon Leak Test CAD

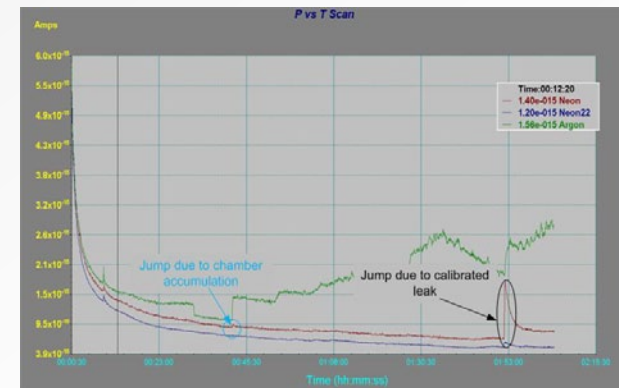

- Leak Test Plot

Seismometer Huddle Testing



- Seismometers to be tested

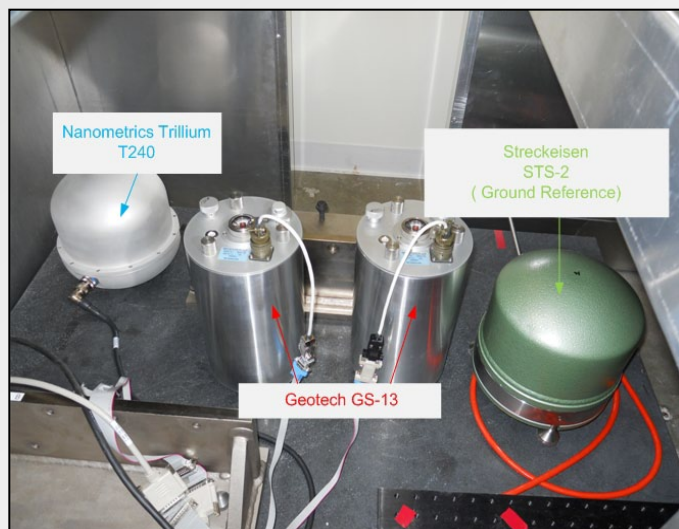

- Huddle Bench

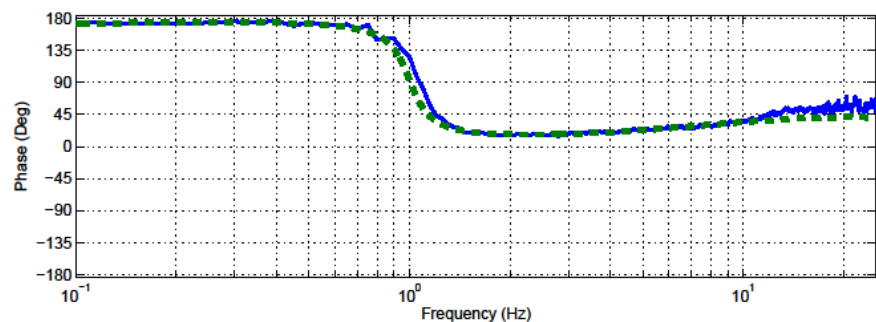
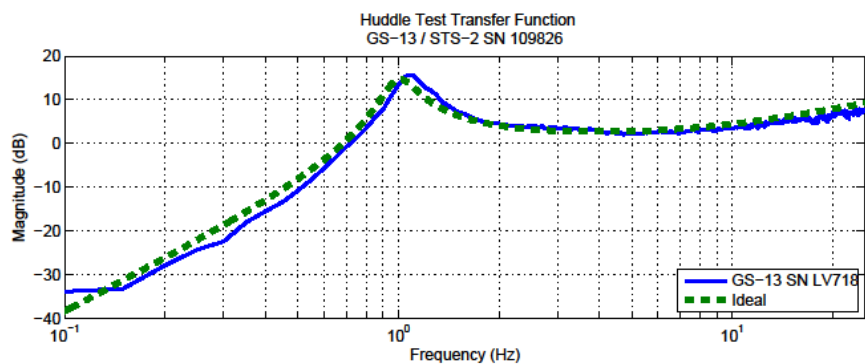

- GS13 Transfer Functions

Testing Overview

Several Levels of Testing

- Device Level testing
- Sub-assembly testing
- Major assembly testing

Major assembly testing

- Phase I: Post-assembly
- Phase II: After SUS integration
- Phase III: Commissioning in the chamber

Procedures

- Detailed description of the tests to perform
- Acceptance criteria
- Where the data must be saved in the SVN

Test reports

- Spreadsheets, Results, SVN Location, etc...
- Comparison with reference results



Testing Automation and Status

Automation of the testing process:

- Measure transfer functions, Power spectra with calibration
- Digitize filters
- To engage/disengage filters, ramp up/down control gain
- Perform Tests automatically
 - ✓ Static tests
 - ✓ Hysteresis-linearity test
 - ✓ Range of motion
 - ✓ Calibrated power spectra
 - ✓ “Auto-generate” table report, “Auto-save” data and figures at the right location and the right name

Status:

- LHO
 - ✓ 3 units tested
 - ✓ Tests restart next week
- LLO
 - ✓ 3 units tested
 - ✓ Tests restart this week

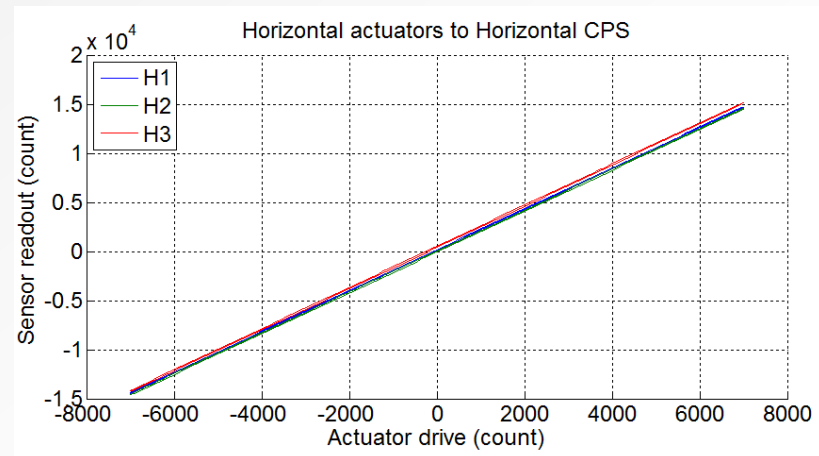

- A support structure (Stage 0) and Two suspended active stages (Stage 1 & 2).
- Will be installed for Advanced LIGO into the BSC chambers.
- A BSC-ISI system in each of the 15 BSC chambers.
- Optic table supports the core optics.

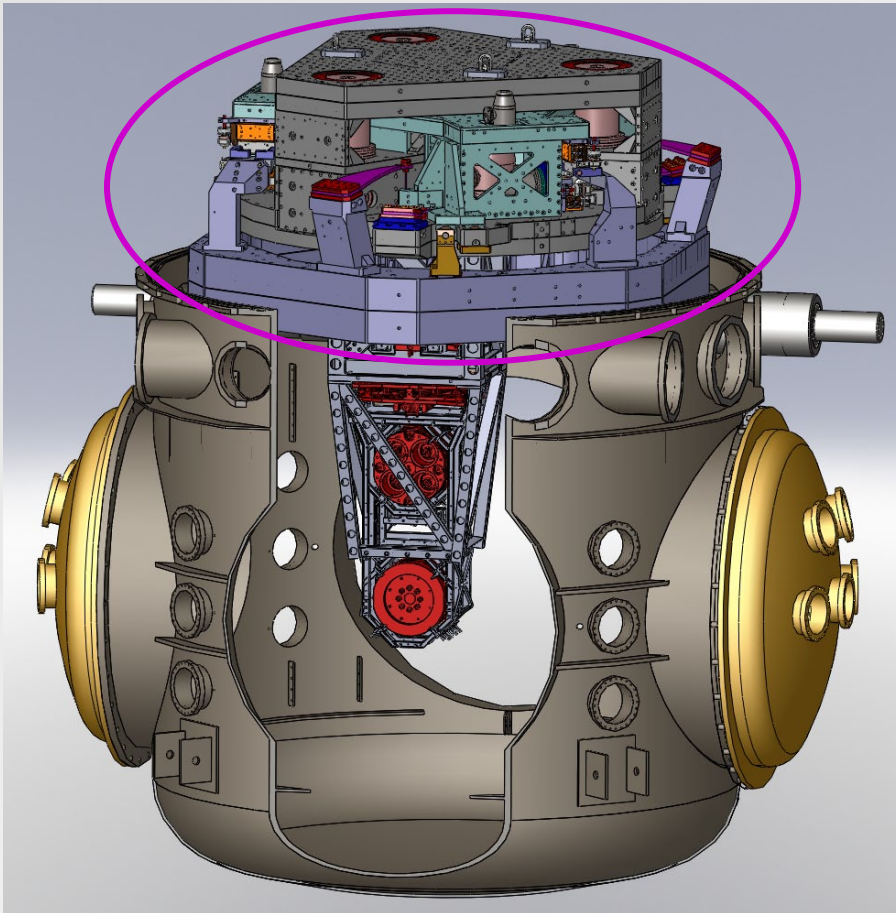

CAD Model of the aLIGO BSC-ISI supporting a Quadruple Pendulum

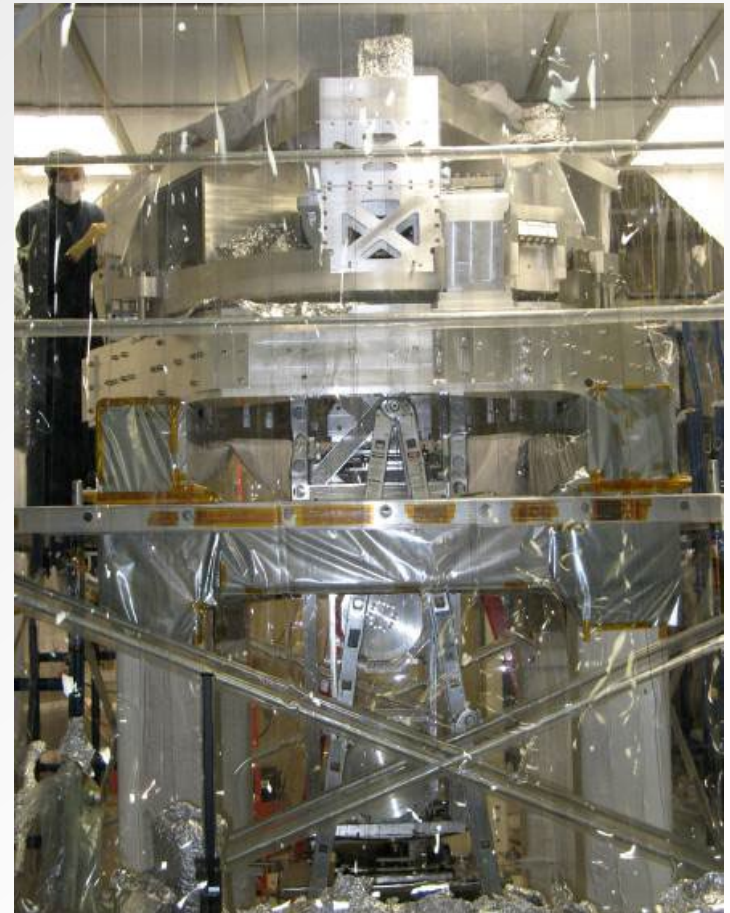

Prototype BSC-ISI on its assembly stand at LASTI.

BSC-ISI Overview:

- Two-Stage Isolator
- Internal (In Vacuum)
- 12 Degrees of Freedom
- Positioning and alignment
- Active isolation
(0.1 Hz to ~25 Hz)
- Passive Isolation
($1/f^4$ from a few Hz to ~100Hz)
- Prototype at LASTI since 2006
- Advanced LIGO First Unit Built at LASTI in 2010.
- Will be used on all of the 15 BSC chambers

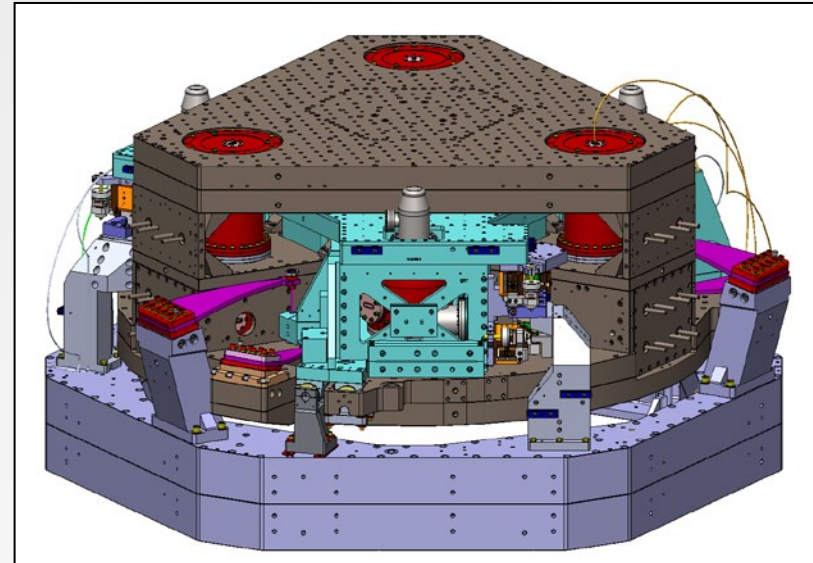

Both suspended stages and have 6 degrees of freedom:

- Blades provide the vertical flexibility
- Rods provide the horizontal one
- Suspension frequencies in the 1Hz-7Hz range
- Passive isolation from few Hz to ~ 100Hz
- Active isolation in the 0.1Hz-20Hz range.
- Active control positioning



BSC-ISI as built for the prototype installed at LASTI

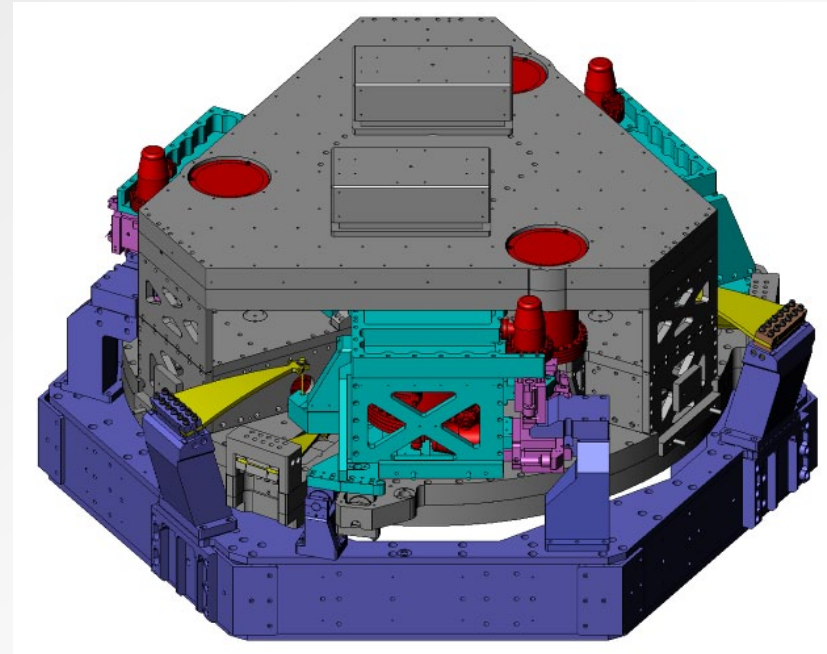

- Stage 0 in violet
- Stage 1 in cyan
- Stage 2 in grey
- Blades and flexure in yellow
- Sensors in Red
- Actuators in Pink

- Dirty assembly at LASTI (2006)

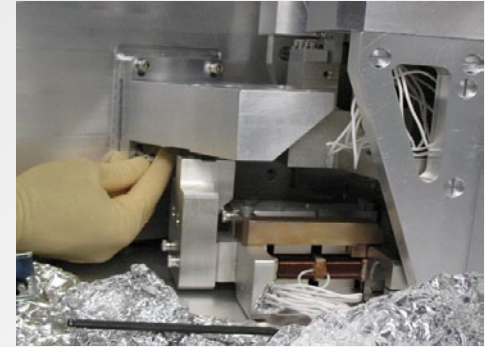
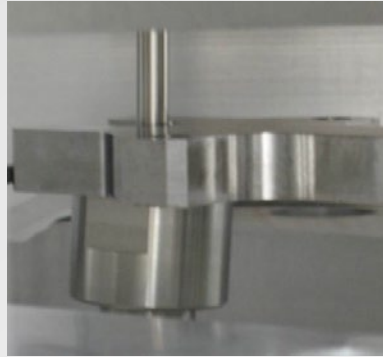

- Clean assembly (2007)



- Commissioning (2008)

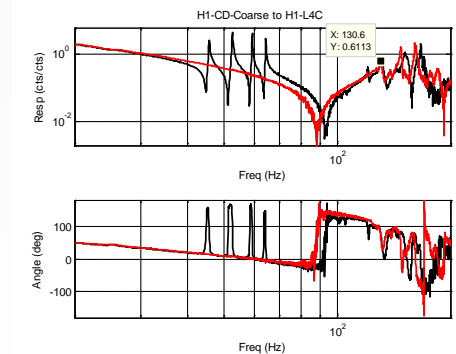
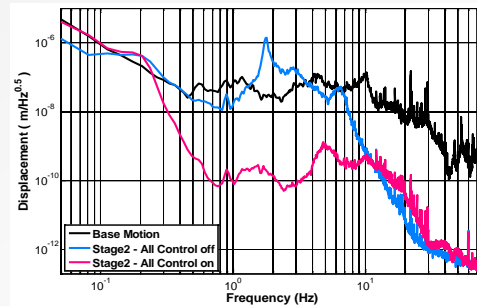
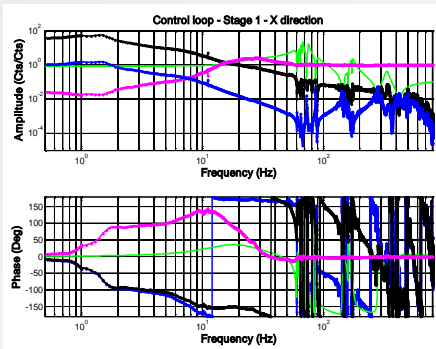

Global isolation (Active & Passive)

- The ground motion is shown in Black. It is measured with a STS.
- The HEPI motion is shown in Blue. It is measured with HEPI L4Cs.
- The motion of stage 2 when the control is off is presented in Red
- The motion of stage 2 when the control is on is presented in Purple
- The relative requirements are presented in Grey

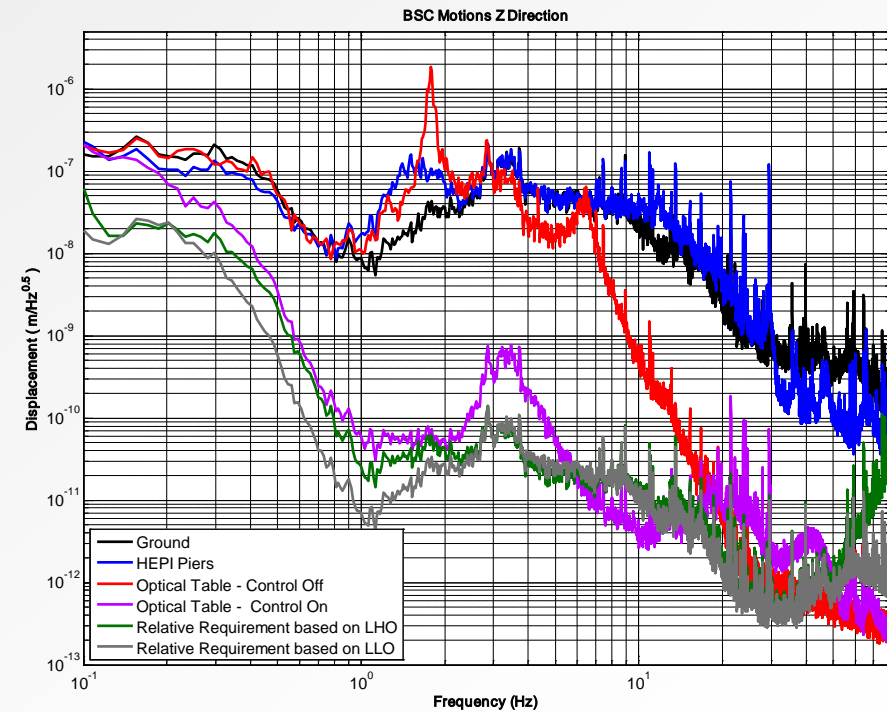
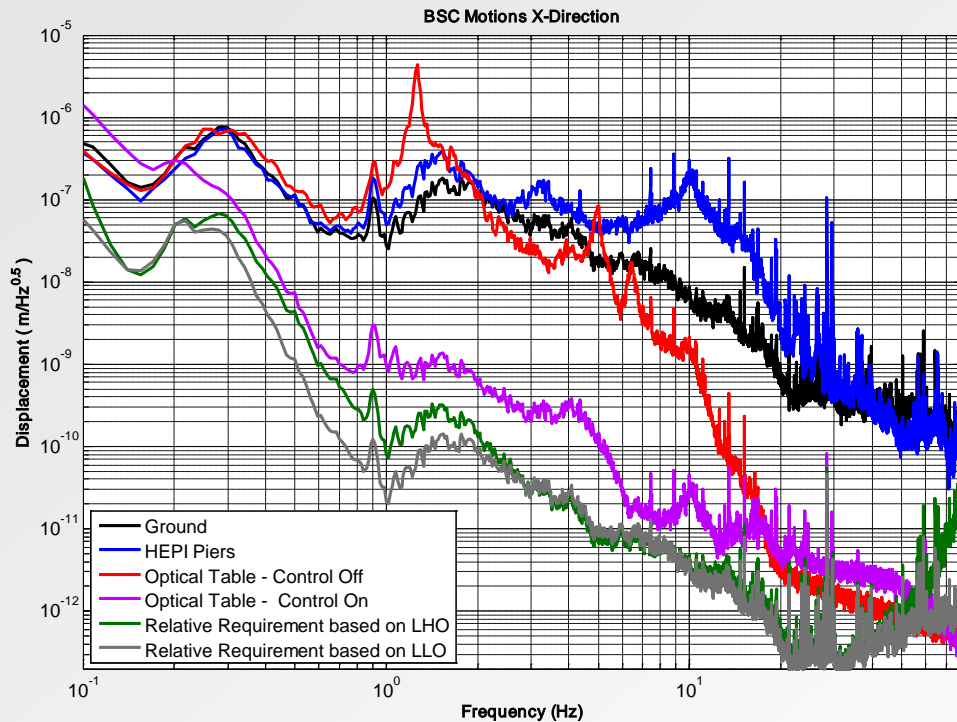

- Predictive noise budget for Advanced LIGO, the document G0810021-v1
- At 17Hz the seismic noise was below the other sources of noise.
- Estimation based on the BSC-ISI performances as of November 2008.
- Performance improved since

Factor of 50 Improvement at 10 Hz.

Active Control Isolation performance: Z-GS13

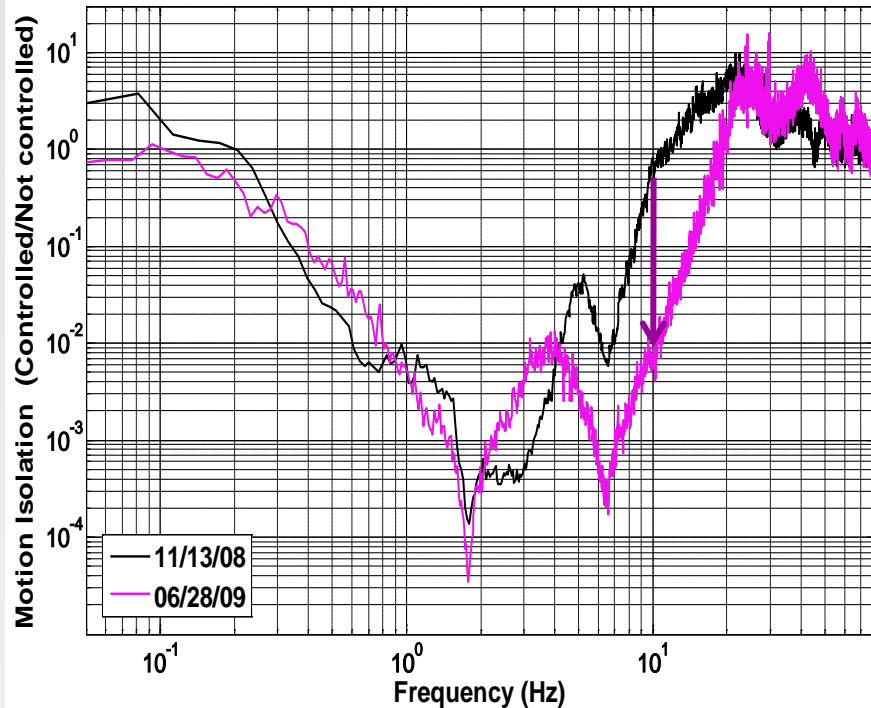

Low Frequency noise

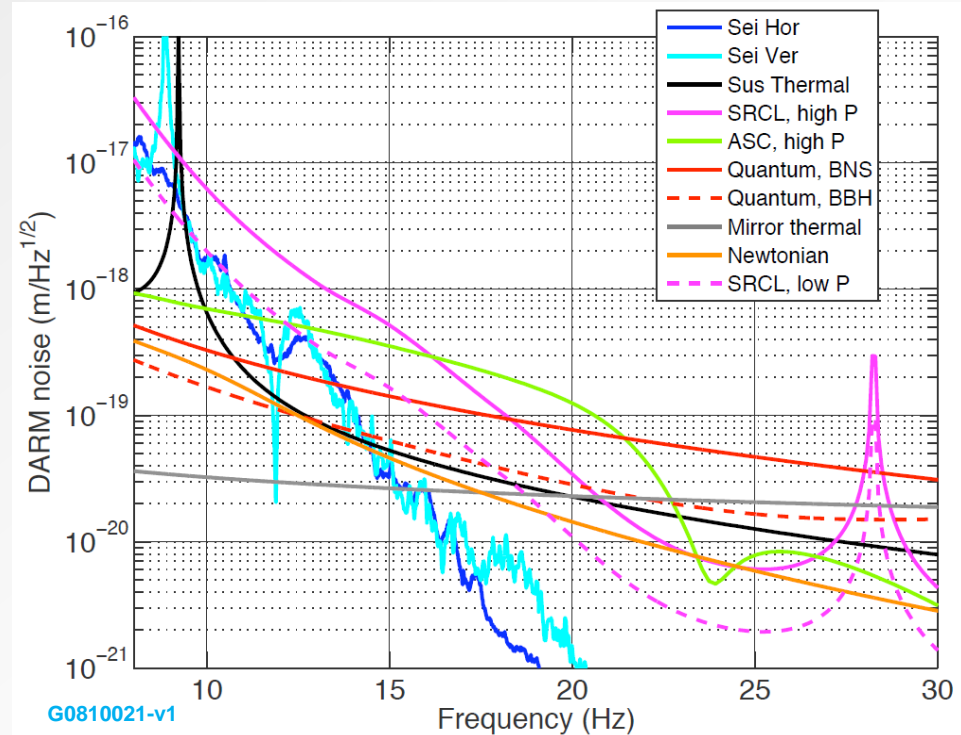

BSC-ISI Re-design (2009-2010)

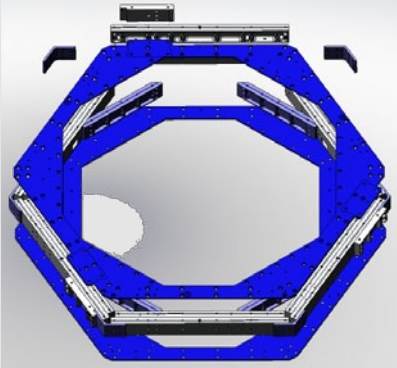

- Stage 0 Before Re-Design

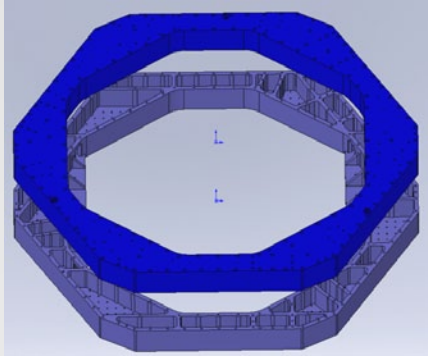

- Stage 0 After Re-Design

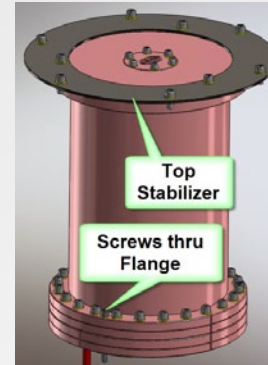

- Pods Stiffener

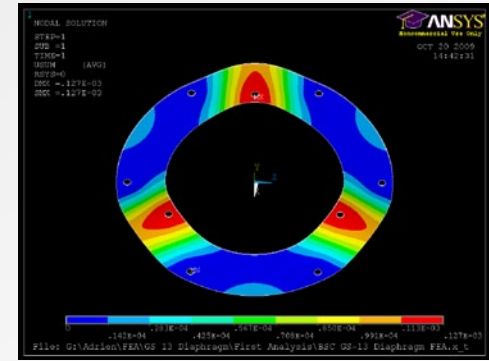

- Stiffness Optimization

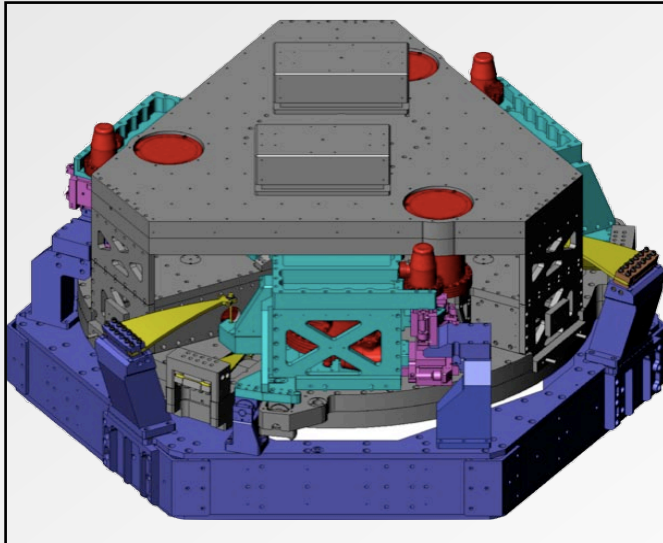

- Initial Design

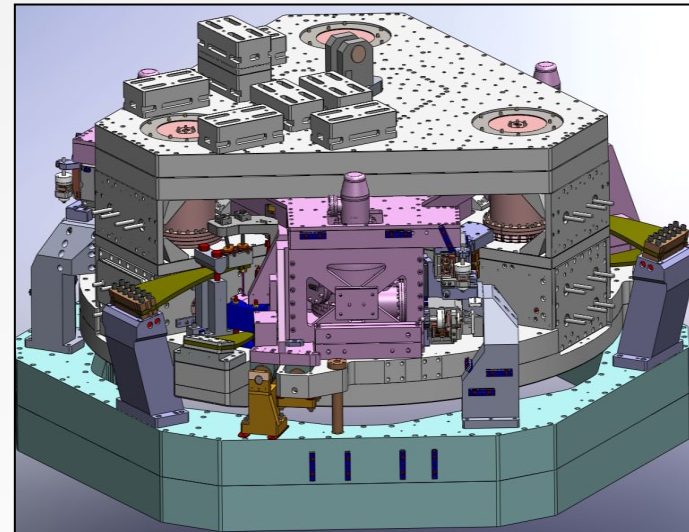

- Final Design

April 2010 – April 2011

BSC-ISI Progress Highlights

- **4.1 Design**
- **4.2 Procurement**
- **4.3 Assembly**
- **4.4 Performance**
- **4.5 Testing**

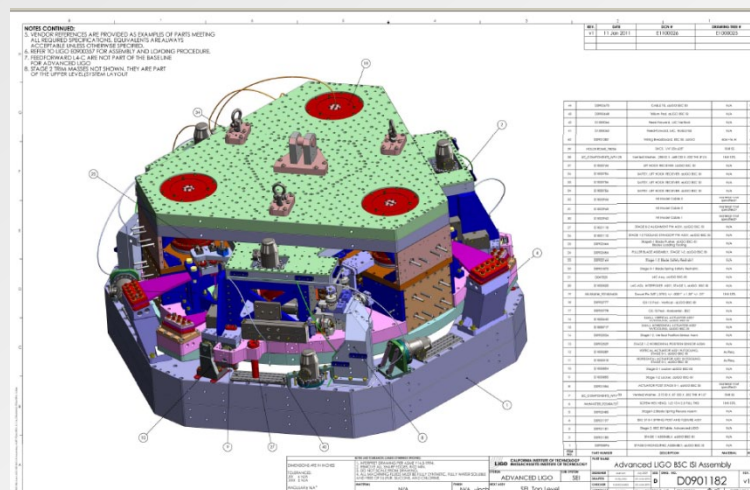
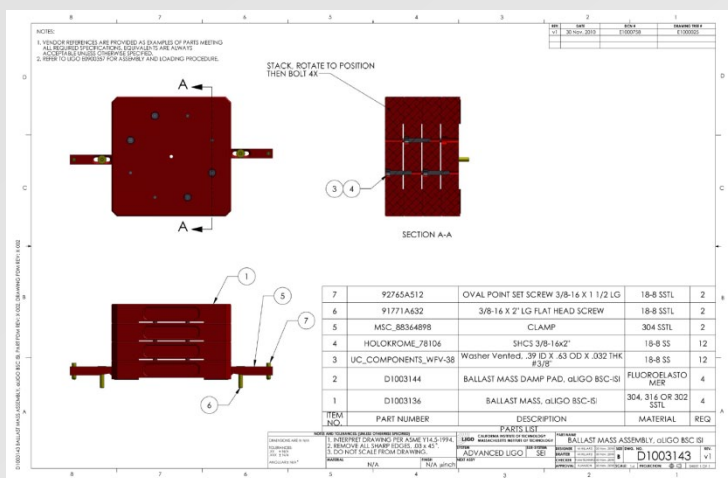

- Design Completed (+200 drawings)
- Design adjustments upon discussions with shops
- Assembly Drawings
- Bill of materials
- List of Parts
- Assembly Procedure. Main assembly and sub-assemblies: Sensors, Actuators, Flexures Assembly, Lockers...

SEI Integration at the system Level

- Layout, Mass budgets and Balancing:

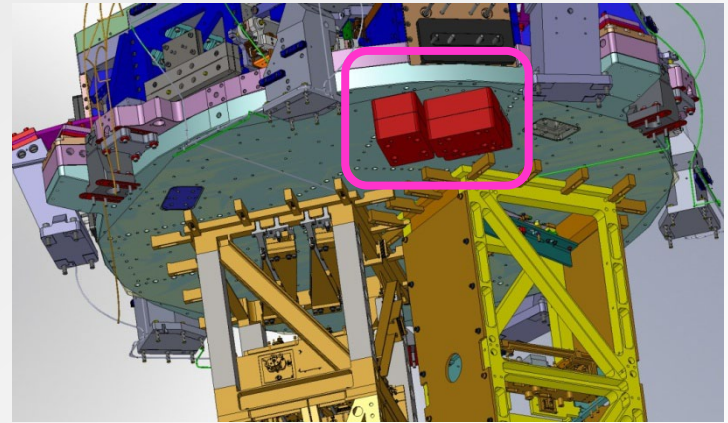
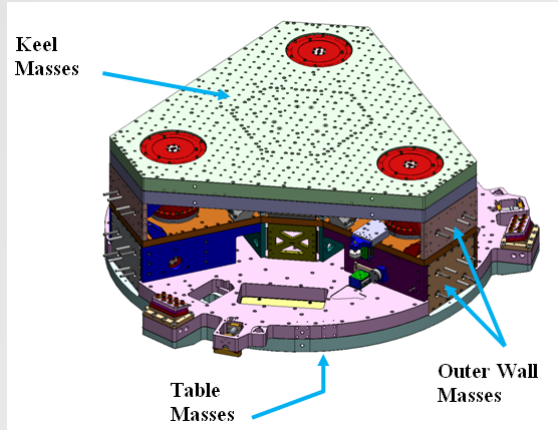

- Cabling and Flanges Layout:

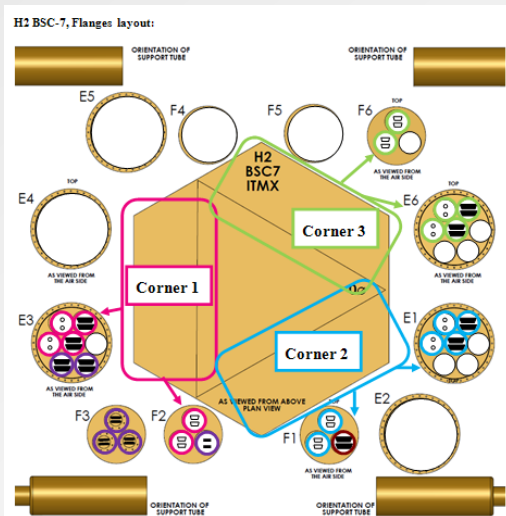

- **Procurement Process**
 - Statements of work
 - Bidding Process
 - PO issuing
 - Communication with shops

- **Quality Control**
 - Shipment
 - Cleanliness
 - Parts Cleaning
 - Inspection
 - Process improvements
(Machining, Cleaning...)

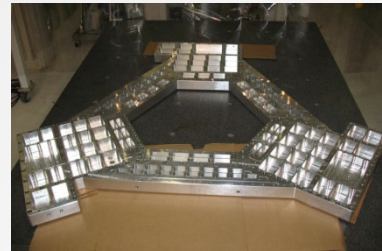

Black splotches (as-received)



Inventory , Cleaning



- Actuators Posts and Parts



- Parts ready for cleaning



- More Parts ready for cleaning

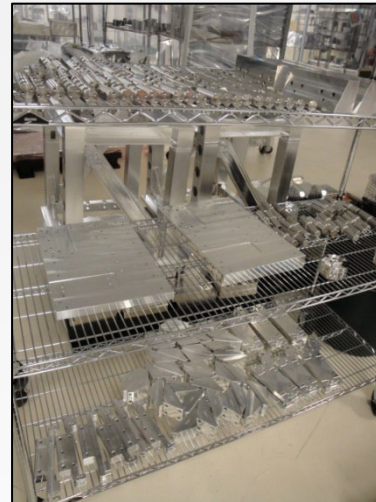

- And more parts



- Cleaned and labeled by sub-assembly

First Assembly at LASTI

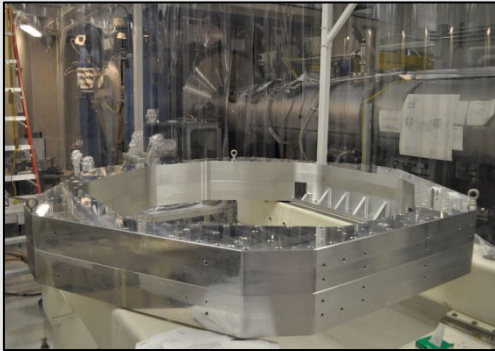

■ Stage 0

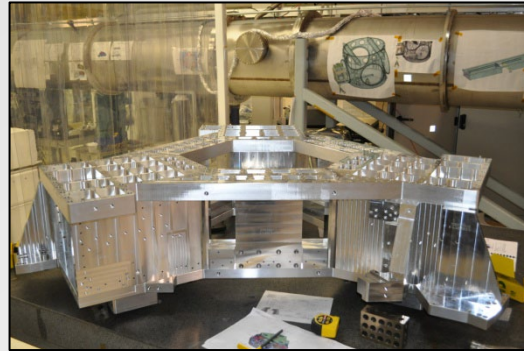

■ Stage 1

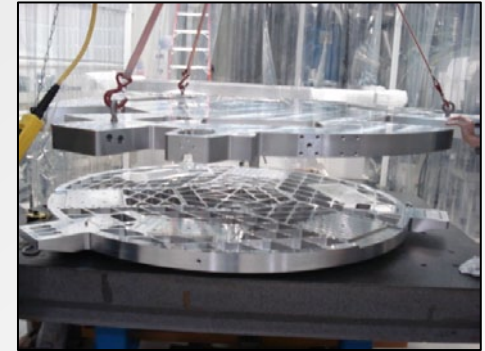

■ Optical Table



■ Sub-structures Connection



■ Stage 0, 1 and 2

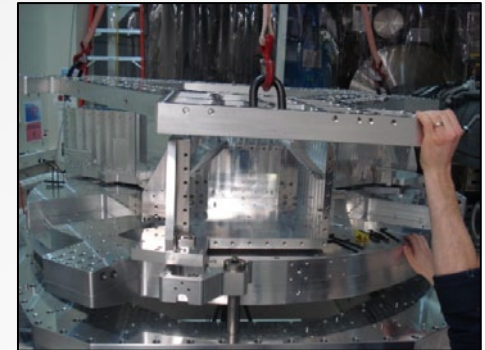

■ Closing Stage 1

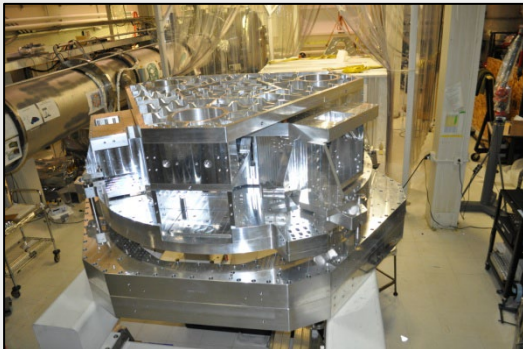

■ Closing Stage 2



■ Actuators



■ GS13

First Assembly at LASTI



- A few seismometers



- Trilliums in pods

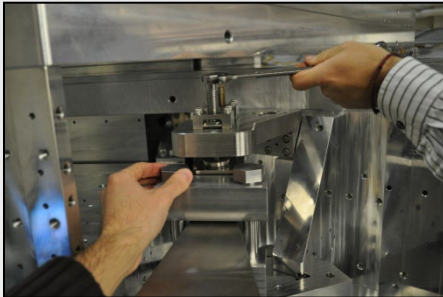

- Small
Blades
Loading



- Large
Blades
Loading

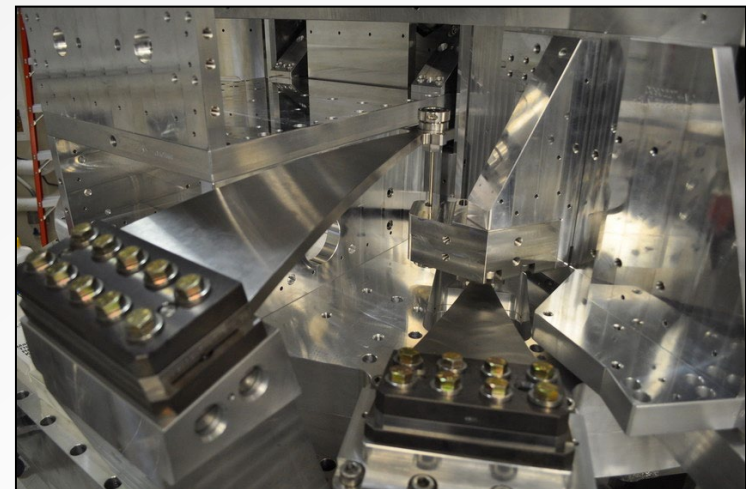

- Blades Loaded

Modal Testing results of the new Stage 1

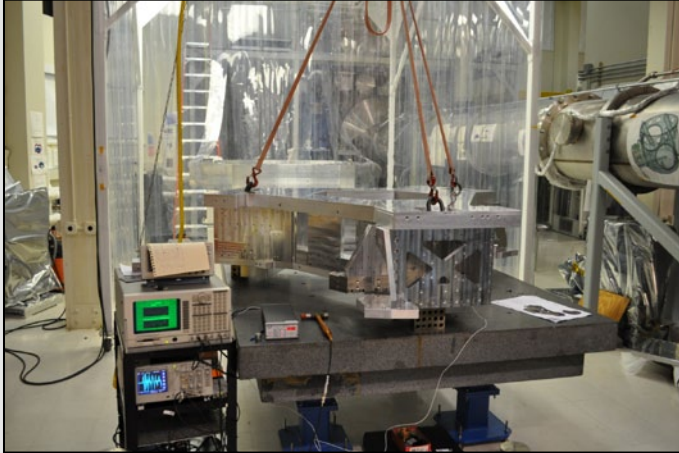

■ Testing Set Up

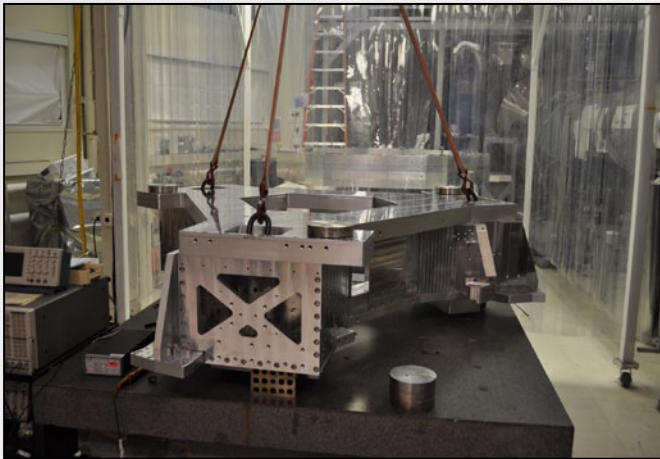

■ Damping Tests

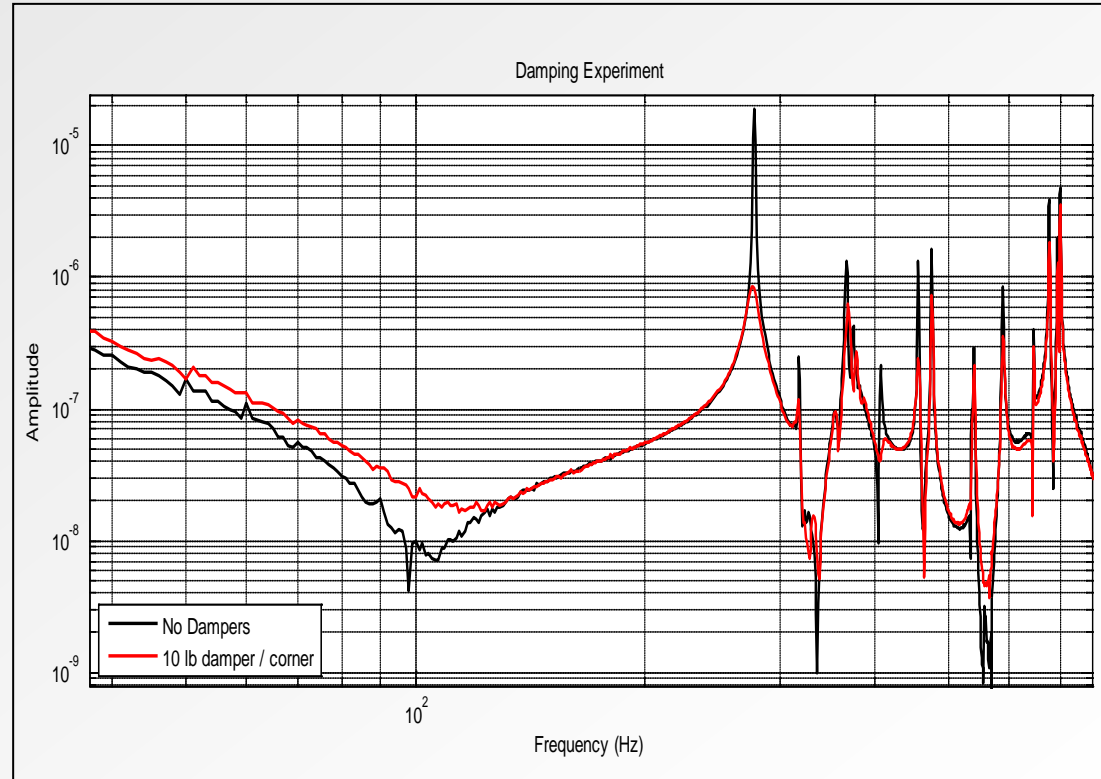

■ Testing Results

Low Frequency and high frequency investigation :

Stage 2 - RY to RY, GS13 - 05/26/09

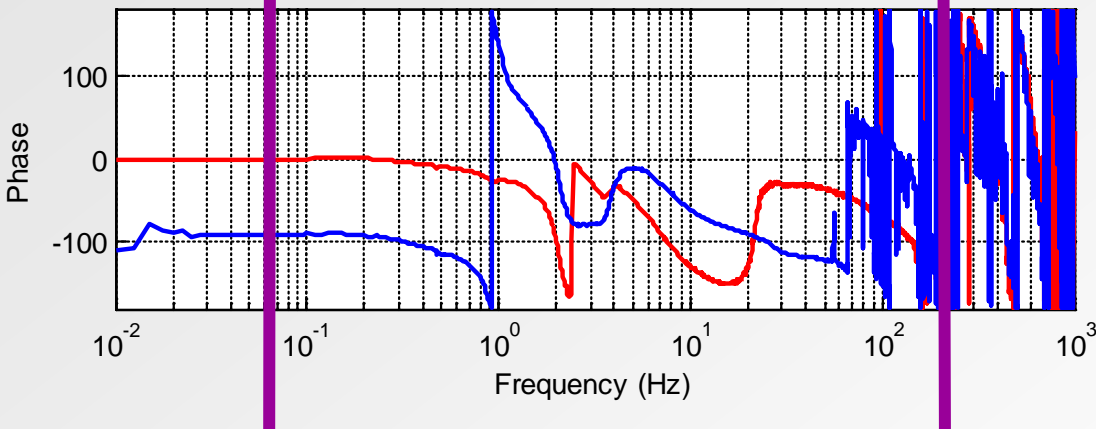
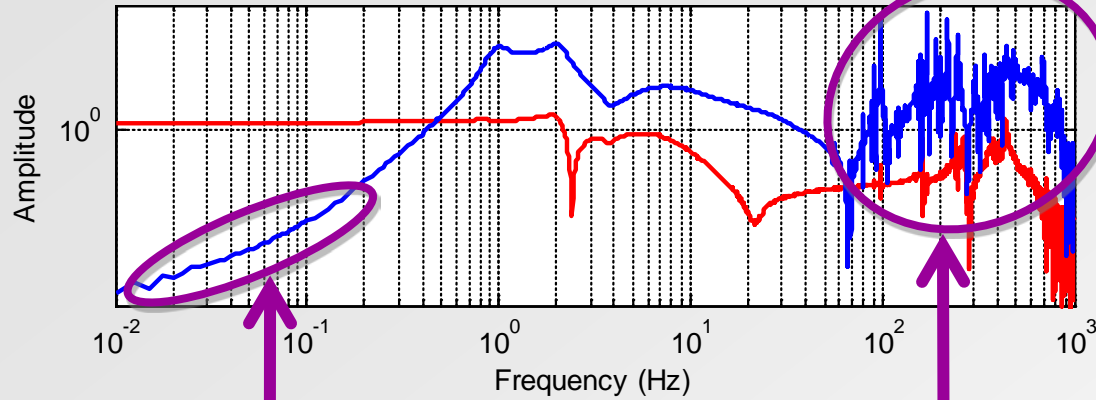

Electromagnetic Couplings

Structural Resonances:

- Global Modes
- Pods
- Quad Structure

Mu Metal Cans:

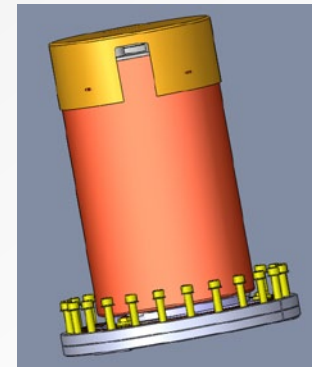

□ Structural Modes Damping

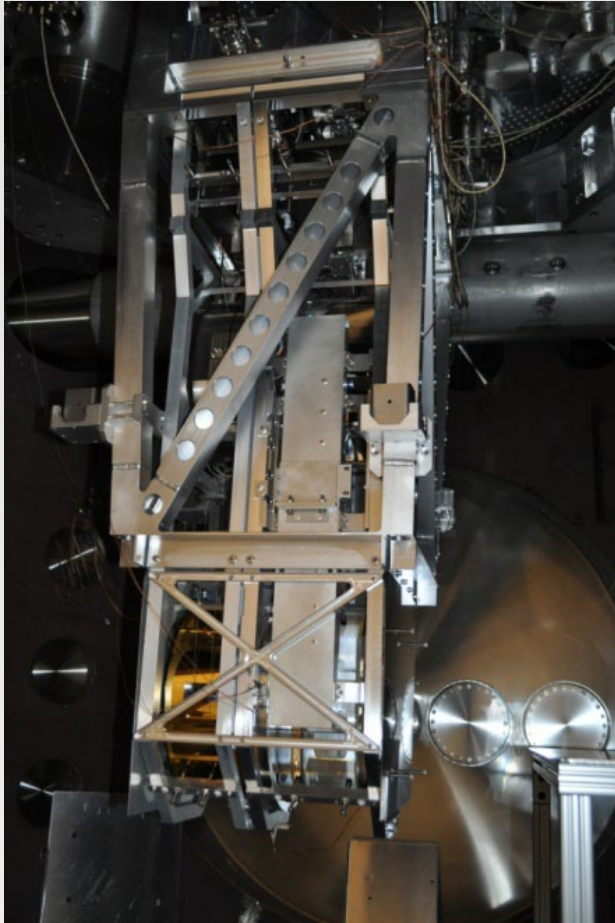

- **Vibration absorbers on the Quad Structure at LASTI**

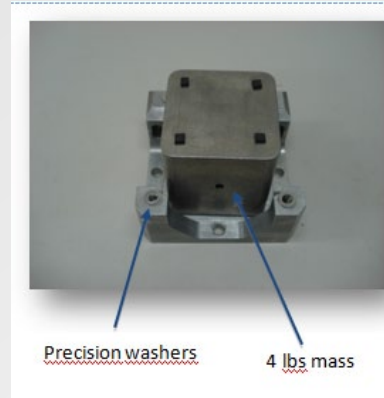

- **Vibration absorbers**

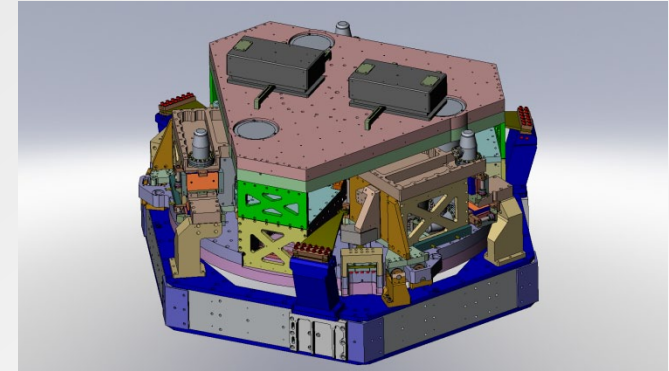

- **Counter-balance masses used as Vibration absorbers**

Stage 2 RY - GS13 Transfer Function

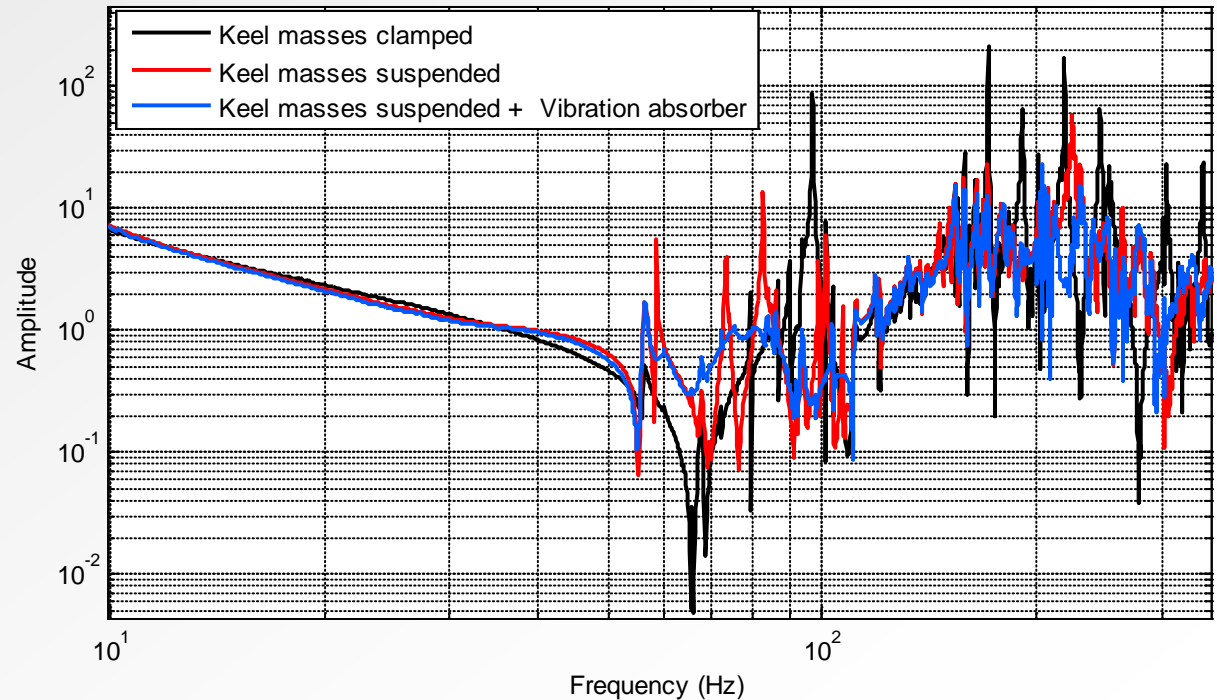

- **Transfer Functions Improvement**

- About 150 Vibration absorbers for all types of suspensions:

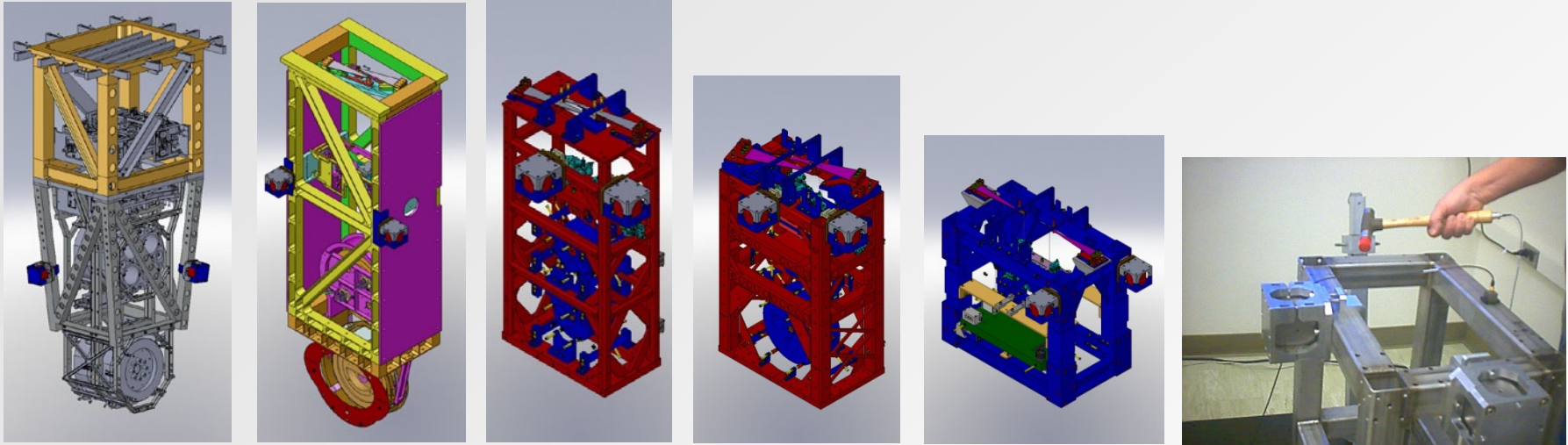

- Vibration absorbers for Stage 2 and Stage 1:

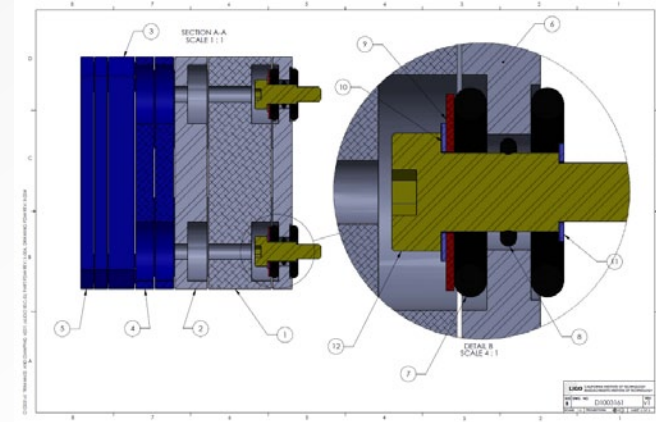
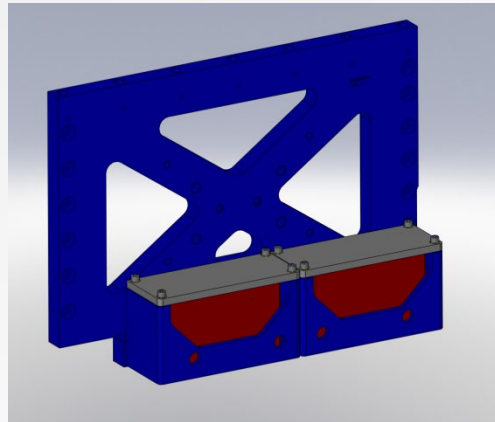
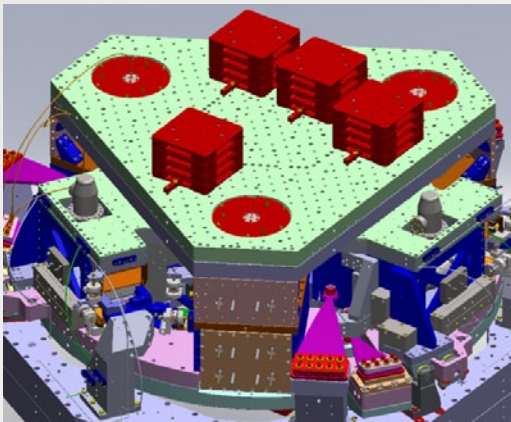

Progress on Testing preparation list from April 2010

Preparation of the commissioning of 15 articles:

- Procedure and instruction for testing, commissioning
- Definition of standards for data acquisition and control design
- Preparation of templates for expected results
- Data storage subsystem by subsystem
- Coordination of subsystems parallel commissioning
- Handoffs preparation
- Definition of acceptance tests
- Manpower
- Training

Testing and Commissioning Preparation

Preparation

- DCC Structure similar to the HAM-ISI
- Testing procedure – Phase I in progress
- Control commissioning scripts ready

Needs for automation

- Strongly coupled system (Stage by Stage and $H \Rightarrow V$)
- Controlling one degree of freedom affects all the dynamic
- Low frequency measurements (from 10mHz) \Rightarrow Long measurements
- Implementation of the control in 15 Steps (~ 100 filters)
- Experimental MIMO response (~ 400 transfer functions)
- Needs to Reduce the number of measurements

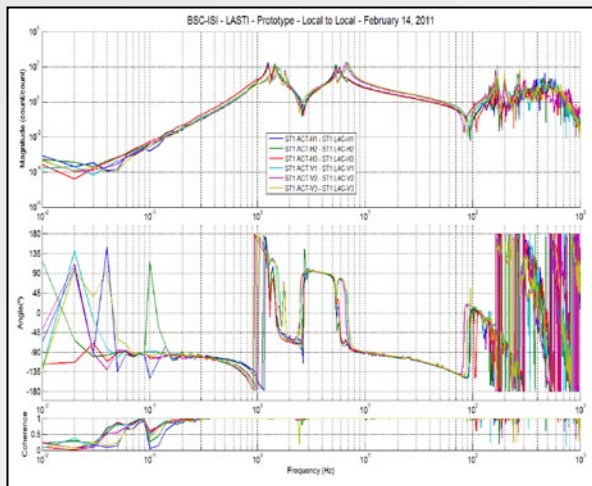

● Local to Local measurements

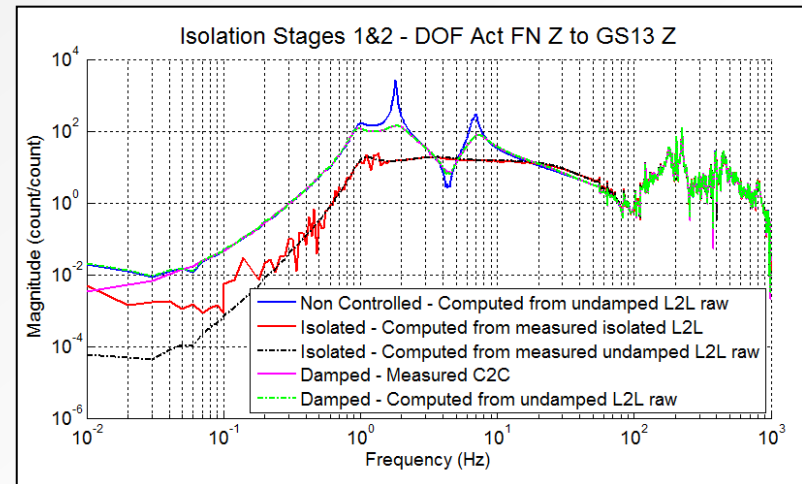

● Control (Level II) with one set a measurements (13h)

Commissioning Scripts

- “Symetrization”, calibration, dynamic, electronic compensation
- Basis change (Local to Cartesian)
- Damping filters
- Blend filters
- Isolation filters
- Filters digitization
- Engaging/disengaging the filters
- Ramping up/down the gain

Levels of Control performances

- Level 0: Damping Loops
- Level 1 - UUG=7.5Hz - (Design ~ 3 min)
- Level 2 - UUG=15Hz - (Design ~ 3 h)
- Level 3 - UUG=30Hz - (Design ~ 3 days)

Status

- Testers trained and ready for the BSC
- Procedure, scripts ready
- Working on the hardware

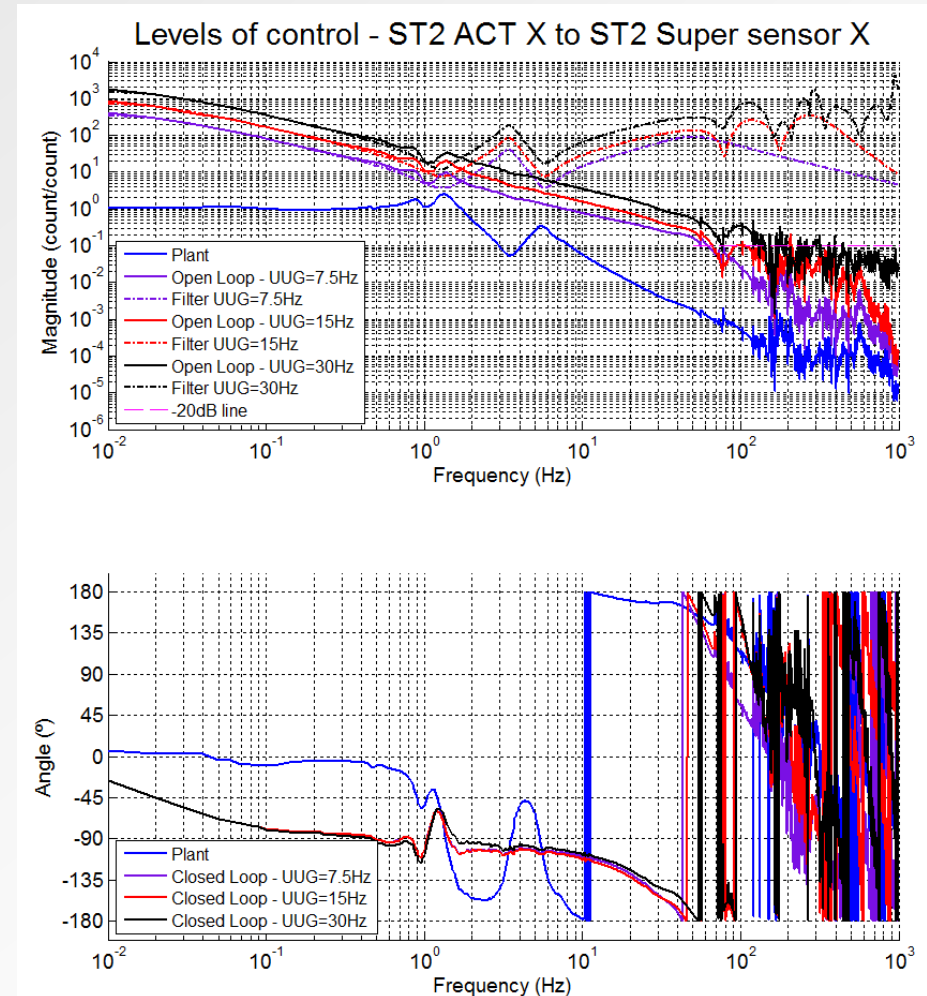

- Example with Stage 2 isolation

If Hydraulic actuator assembly problems occur, then redesign and/or rework will be required.

All actuators assembled and successfully tested. Risk is retired.

If Parker servo valves become unavailable or fail during bench testing, then alternative design may be required.

No failure happened during bench testing. 20% spares have been procured. Risk is retired.

If hydraulic plumbing leak occurs, then repairs will be required.

Design includes plenty of valves and purge plugs to isolate any potential leak. Thoroughly leak check manifolds and tubing before adding fluid. Initial LIGO plumbing went very smoothly. No major leaks in 6 years of operations at LLO. Risk is low.

Contamination of hydraulic system will cause valve failures.

Additional flushing steps are being done for advanced LIGO plumbing. All valves, actuators, and filters are being flushed. We have spare valves to minimize down time. Accumulators are being changed. Risk is lower thanks to actions taken during the past year.

If Sercel L-4C Geophones failure rate increases, new design may be required.

Failures most likely to occur during shipment, initial assembly, and installation. Spares have been procured. Recent experience indicates all is in handling. They are handled very carefully. Risk is low.

If Steckheisen STS-2 seismometers are discontinued, then replacements may be required (STS-3); that may cause interface problems.

Switched to Nanometrics T-240. All T-240s have been delivered. We have procured spares. Risk is retired.

If Pod assemblies leak and require replacement, costs will be increased.

All pods components are Helium leak checked at supplier. Pod assemblies are filled with Neon and RGA scanned. Production run to date, including installation, demonstrates success to date. Have internal pressure sensors to help ID catastrophic leaks if they occur. Maintain adequate supply of preassembled neon gas filled pods available. Risk is reduced.

If BSC isolation does not meet requirements, additional R&D or lowered performance may result.

BSC at LASTI has demonstrated performance which does not limit the GW band. Keep R&D going on suppressing chamber modes, feedforward, tilt sensors. Focus on horizontal-tilt coupling. Very promising feed forward results. Also very promising testing on the first unit assembled. Risk is low.

If HAM isolation does not meet requirements, then additional R&D or lowered performance may result.

HAM6-ISI has demonstrated excellent performance. New cross beams will help. Feedforward isolation can improve the performance around 10 Hz. About to be tested at LASTI. Risk is low.

Wandering plant resonances in combined SEI-SUS system limit performance in SEI

One source of wandering resonance was the tall stacks of trim mass, which have been redesigned (and fixed). The other is from the quad frame, which will be damped by the new vibration absorbers. Risk is much lower thanks to the damping development done this year.

If GS-13 instrument vendor is lost, then delays to schedule occur for long lead procurement items and costs are increased.

All GS-13s have been delivered, including spares. Risk is retired.

Seismometer locks are weak point in reliability.

Trillium substituted for STS-2: eliminates one locker. More robust flexures adopted for GS-13, eliminates other locker. Risk is retired.

BSC-ISI take longer to build and clean than expected.

The first Advanced LIGO assembly at LASTI is promising. The re-design considerably speeds up the assembly process. One remaining issue regarding the balancing is currently investigated. Risk still exist. Must define a plan to fix the balancing issues in a timely manner.

SEI systems take longer to commission than expected.

Procedure has been designed and tested at LASTI. Control performance implementation will be incremental. We'll start with very robust and easy to implement servo control. Team has been completed and trained. We keep improving the procedure, automating the process, and work on training.

HEPI:

- Strong experience from Initial LIGO
- All HEPI hardware has already arrived.
- Assembly in progress. One BSC already installed at LHO. One HAM already installed at LLO.
- Performance enhancements are investigated

HAM:

- Two built and used in Enhanced LIGO. Very positive program.
- 6 new assemblies were completed and tested for Advanced LIGO.
- Partial disassembly, re-assembly and re-testing due to part defects
- First aLIGO installation scheduled for this summer

BSC:

- Procurement is in very good shape.
- First unit built at LASTI for testing
- Assembly went very well
- Preliminary Testing very encouraging
- Assembly has started at LHO
- Ready for testing and commissioning

Upcoming work:

- Build Two BSC at LHO
- One arm test commissioning at LHO
- Build the remaining HAM-ISI needed for the LLO IFO
- Start the BSC-ISI assembly at LLO