

Facility Modifications and Preparations (FMP)

Technical Status
Annual NSF Review of Advanced LIGO Project
April 25 - 27, 2011

John Worden
LHO

FMP Functions

Prepare for assembly tasks (buildings, laboratories): \$3M, WBS .2.1, .3, .5

Create spaces for use as clean assembly areas

Procure large, soft-walled, clean rooms for assembly

Procure vacuum bake ovens, parts washers.

Create clean/bake & conditioned storage space

Purchase supplies for wrapping, palletizing, storing assembled components

Purchase additional material handling equipment, installation fixtures, optics lab supplies, clean room supplies, etc.

Store completed assemblies

Provide clean/bake service, support the assembly groups.

→ **DONE**

Design & Build Vacuum System Modifications \$5.7M, WBS .4

Convert 2 km at Hanford Observatory to 4 km

Move HAM Chambers for Input Optics (IO) and Interferometer Sensing & Control (ISC) use

Supply new IO tubes (input and output mode cleaner tubes)

→ **Underway with GNB Corp.**

Prepare for installation tasks: \$2.4M, WBS .1, .2.2, .2.3, .2.4

Stage completed assemblies, procure installation equipment

Does not include installation (INS WBS scope) or system/subsystem test/acceptance (PM/systems WBS scope)

Parts processing and assembly performed in Class 100 clean room work spaces.

Processing includes either vacuum bake or air bake (for large plates) to remove Low-Volatile Residue (out-gassing)

Clean storage for parts and completed assemblies.

Track processing and storage of parts and assemblies.

New IO Tubes to meet LIGO vacuum requirements, new mid/end station spools for 2K-4K conversion.

Work spaces completed and commissioned fall of 09.

Ongoing effort to support assembly activity – clean and bake, shipping/receiving, packaging, storing, hiring techs. This is a bigger effort than originally thought.

**Procurement activity for IO Tubes/Vacuum System mods –
–GNB – contract awarded in April 2010, first components undergoing vacuum bake April 2011 with shipment of Mid Station Spools by end of April.**

aLIGO Corner Station LHO

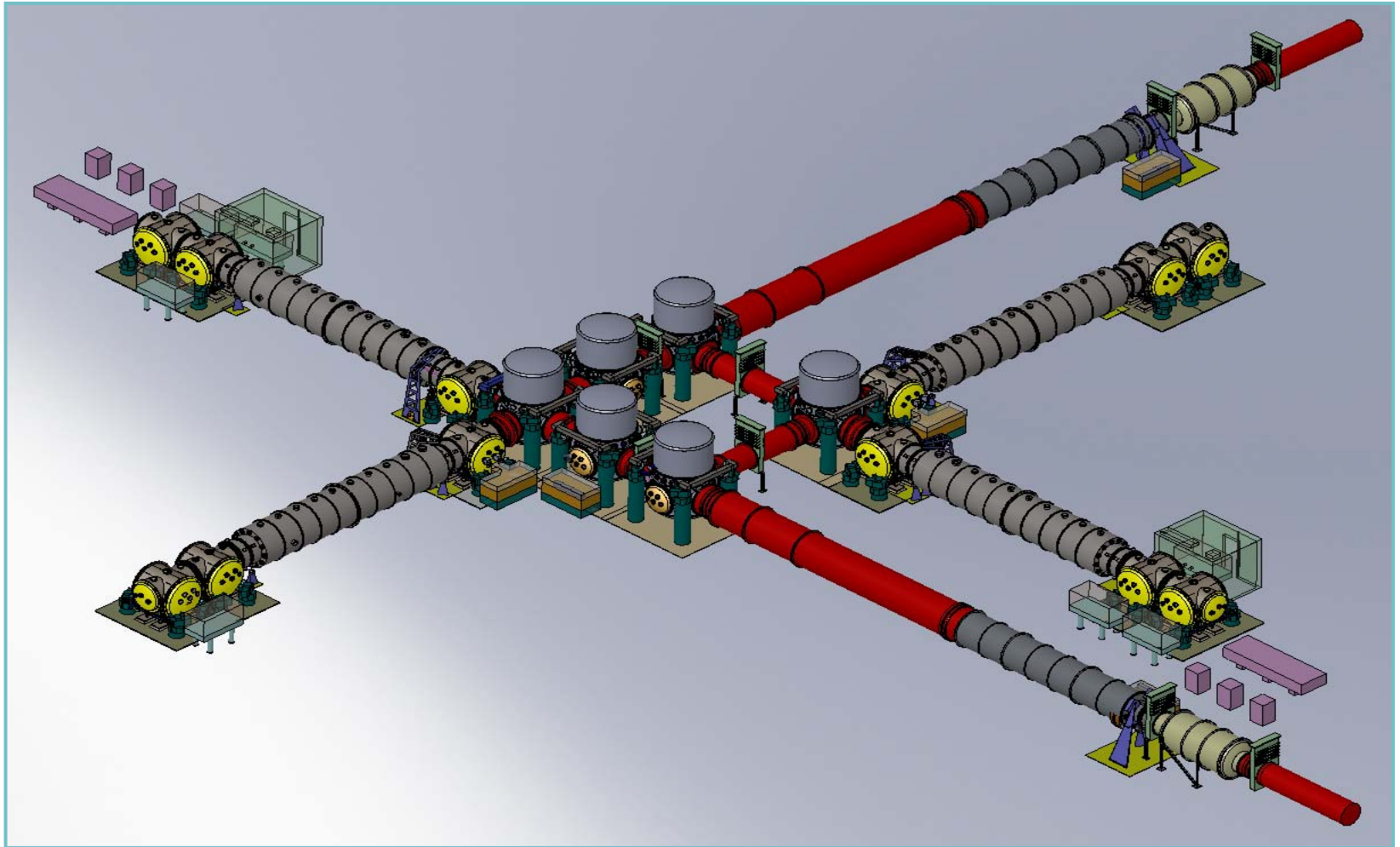

aLIGO End Station LHO

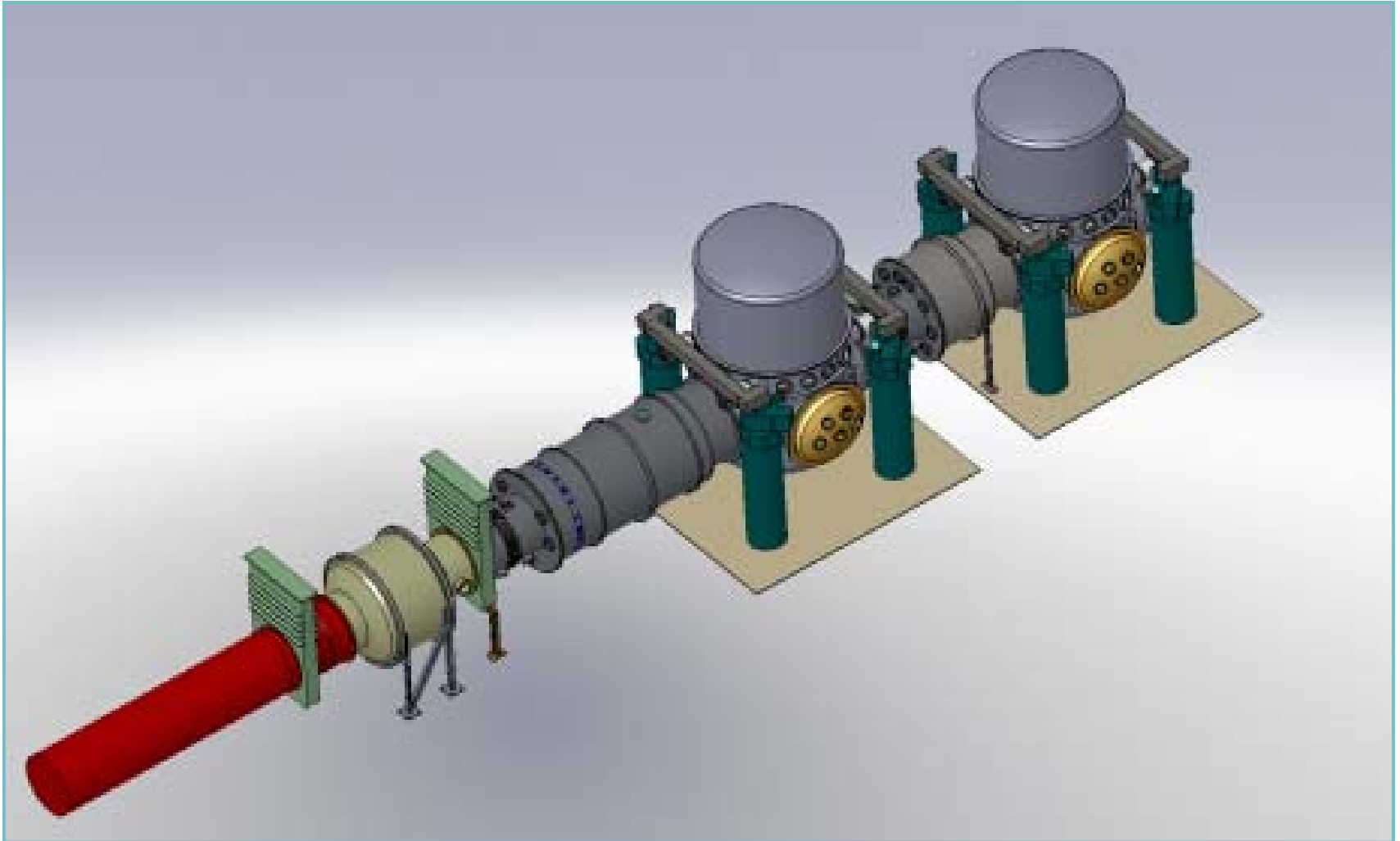

Assembly Space LHO



Clean/Bake LHO



LHO HEPI Pump Carts



Assembly Space LLO



Clean/Bake LLO



LLO:

3 Vacuum Bake Ovens

1 large Air Bake Oven

LHO:

3 Vacuum Bake Ovens

1 large Air Bake Oven



4/25/11
G1100469-v3

- Vacuum Prep Warehouse Drying Station



- Vacuum Bake Oven



- Clean Parts ready for HAM-ISI assembly

FMP to do

Design & Build Vacuum System Modifications WBS .4

Convert 2 km at Hanford Observatory to 4 km

Move HAM Chambers for Input Optics (IO) and Interferometer Sensing & Control (ISC) use

Does not include installation (INS WBS scope)

Get RFP out on the street in Fall of 2009

Fabrication underway.

Underway:

Procure H2 Electronics Building – Slab is in place, modular building delivery ~May 5 (\$130K)

Procure Install Cleanrooms. – First delivery has arrived at LHO. (\$384K)

Procure Cartridge Install Test Stands. – First unit complete April 28 (\$296K)

Procure Cartridge Install Work Platforms. - In design and fab with vendor (\$472K)

Remaining work:

HVAC required for H2 electronics building, H1 electronics, PSL Diode Room

Mezzanine for H1 electronics.

Mid Station Spool Washing



MC Tube Rollups



Cartridge Install Test Stand

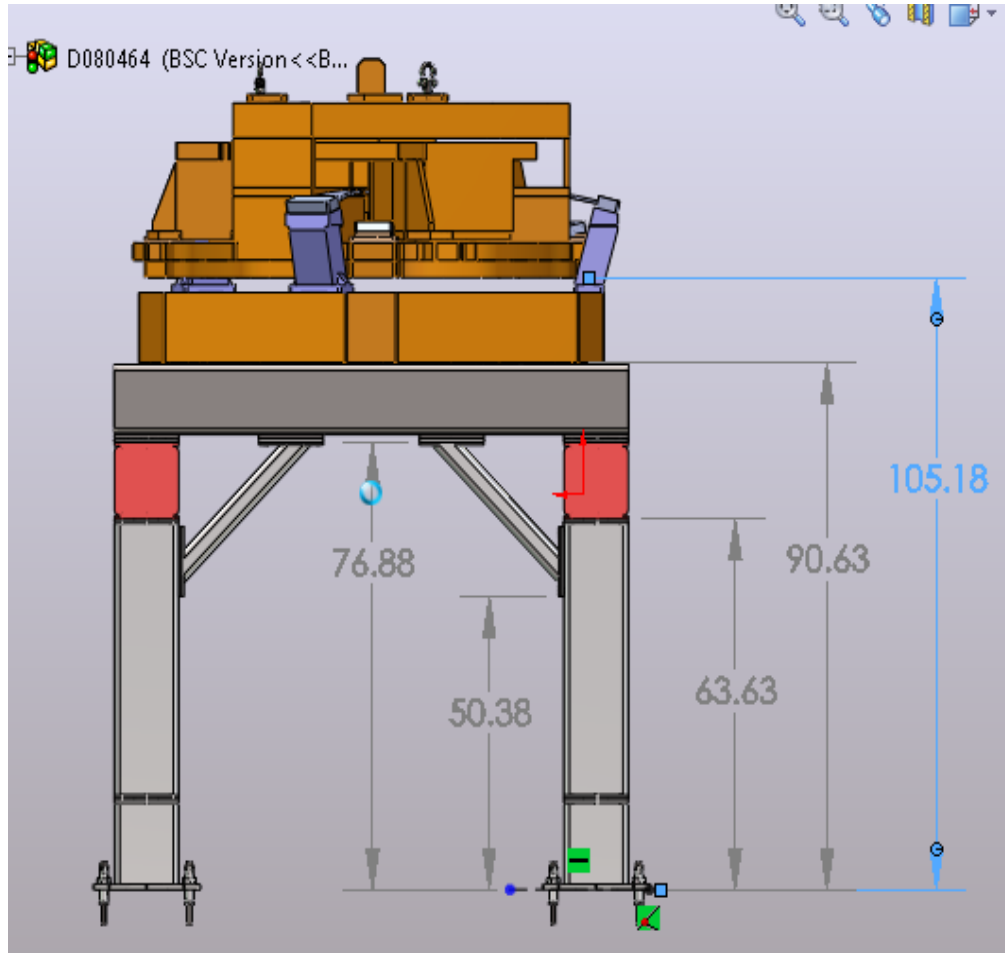

Work Platforms

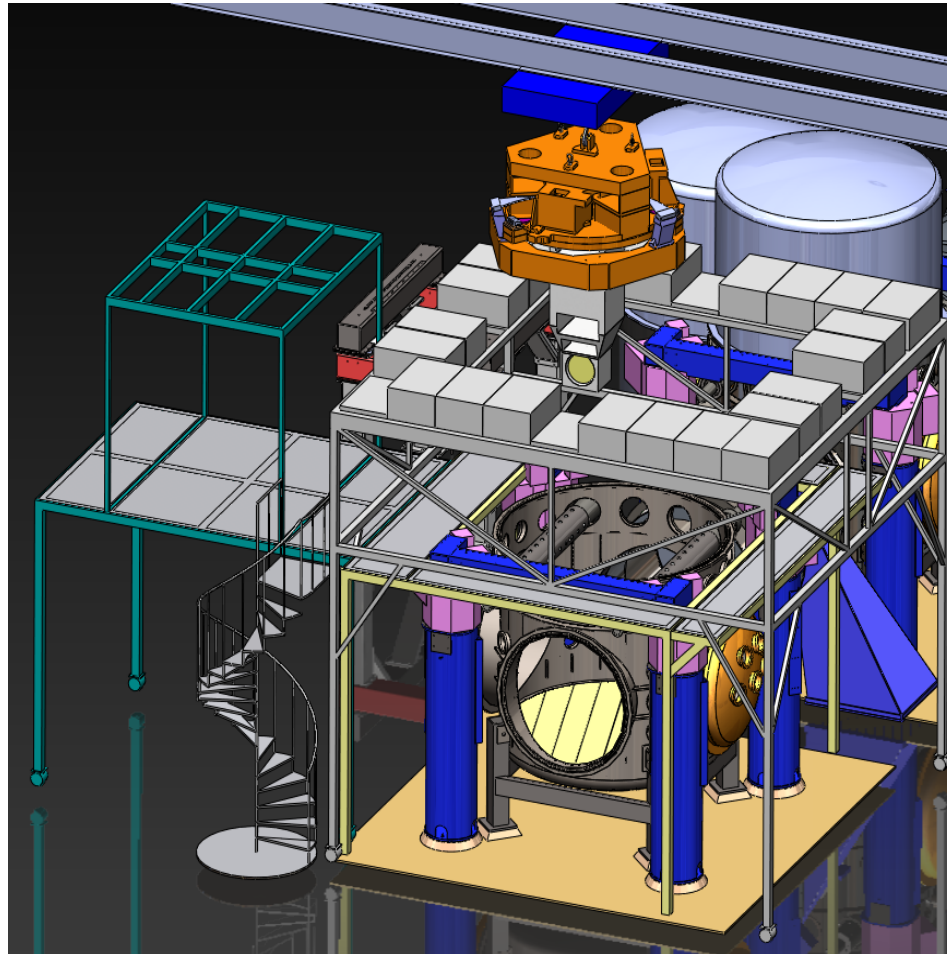

Install Cleanrooms

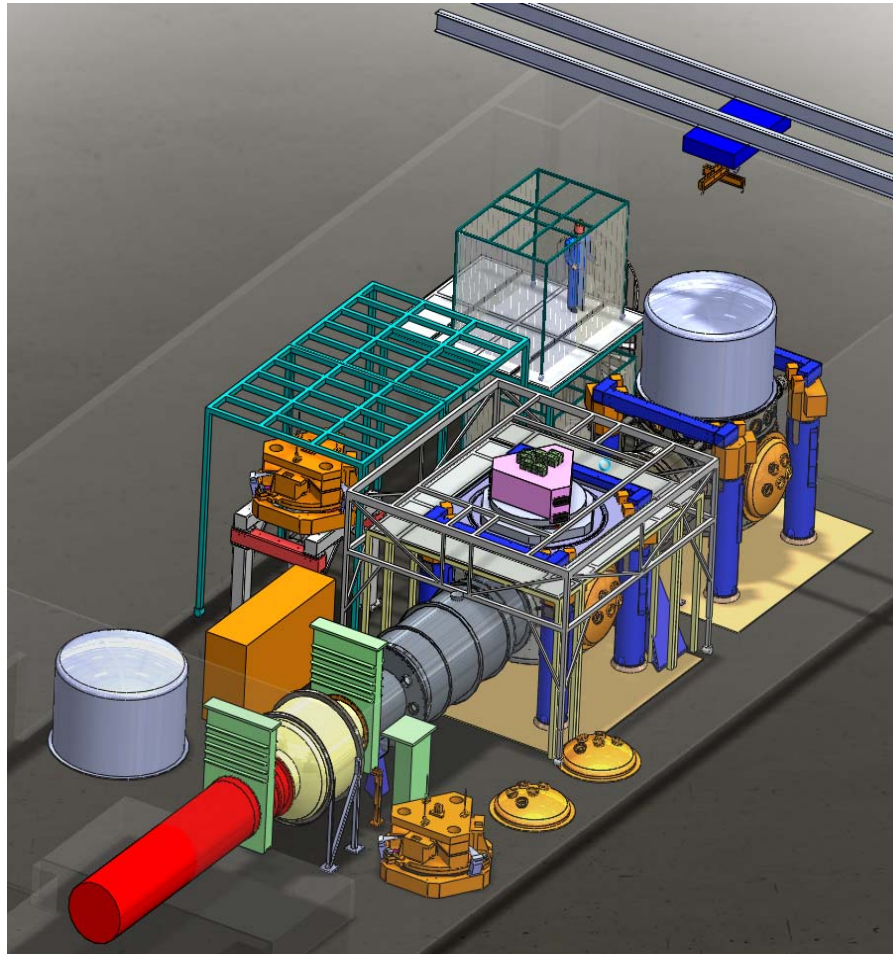

Low technical risk

Maintaining Particulate Cleanliness

**Handling the Simultaneous Assembly Tasks and Space Needs
will be Challenging**

**Will need to fit “noisy” construction activities around operating
IFO schedules.**

**Safety – assembly and on site transport of heavy components
(8000 pounds for assembled BSC system). New laser safety
issues – higher power in test labs.**

**Track and store many parts – will need some manpower and an
inventory system to control incoming materials as well as
completed components.**

**Small quantities of cleaning fluids to be stored and disposed of.
Not new for us.**

Take delivery of new Vacuum components and supervise the install.

Install modular building for H2 electronics.

Procure HVAC for H2 modular building, H1 and Laser Diode room.