

REV.	DATE	DCN #	DRAWING TREE #
v1	18 JUL 2011	E1100681-x0	-
-	-	-	-
-	-	-	-

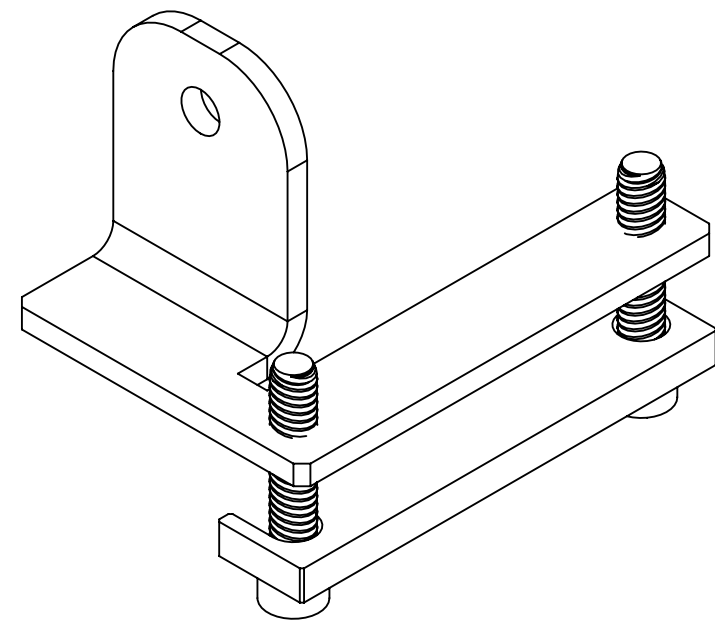

ISO VIEW

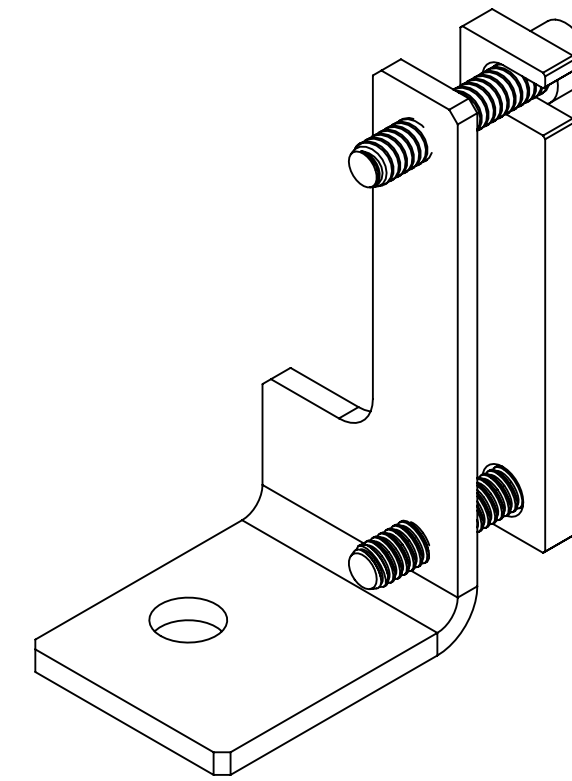

ISO VIEW

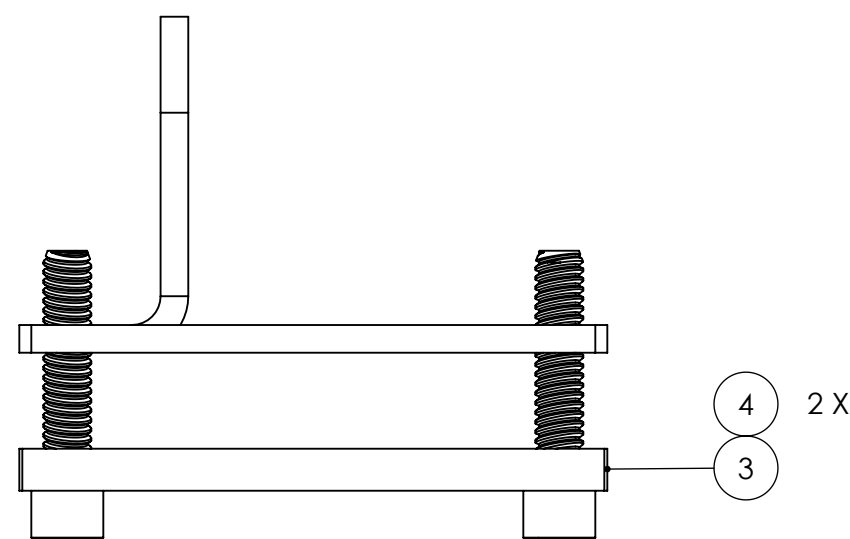
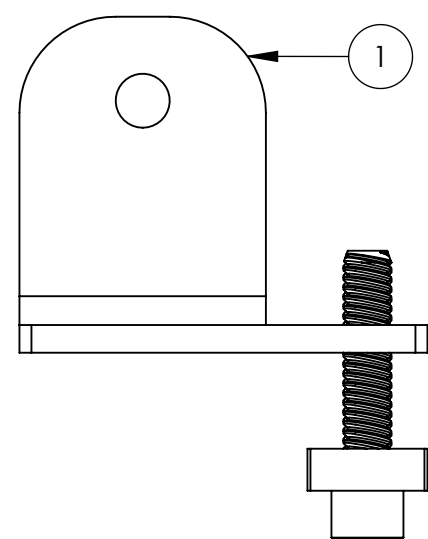

BASIC CONFIGURATION

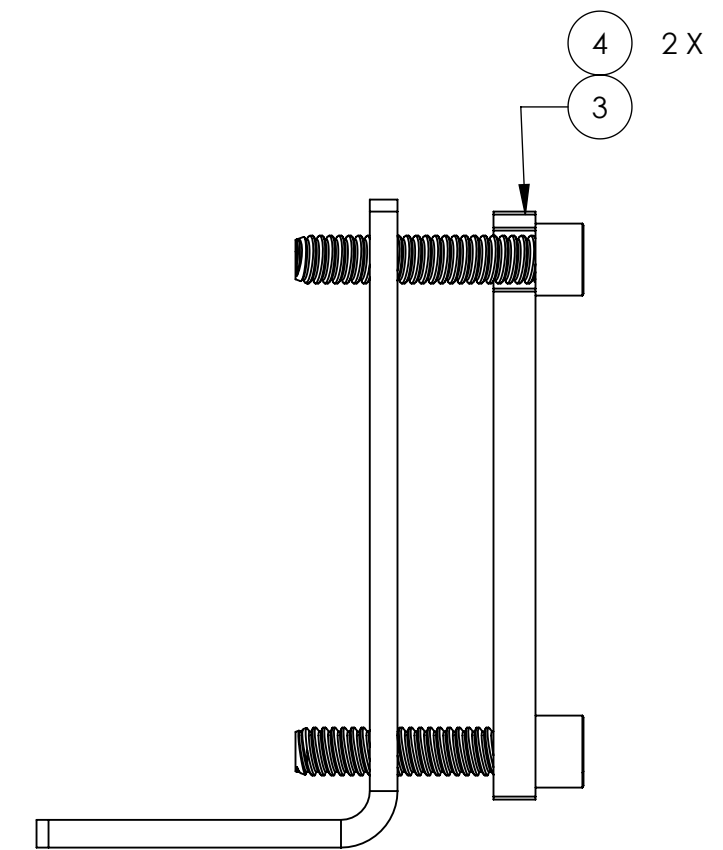
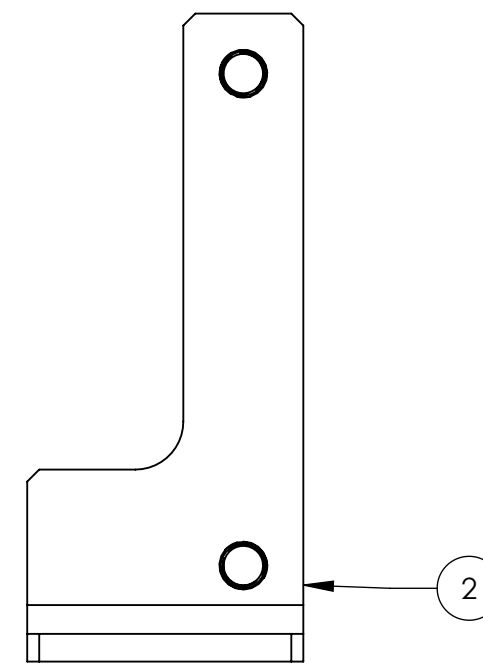

-1 CONFIGURATION

ITEM NO.	PART NUMBER	DESCRIPTION	MATERIAL	D1101305/QTY.	D1101305-1/REQ
4	MS16995-53	SCREW, SHC, 1/4-20 X 1.25 LG.	300 SERIES SSSL	2	2
3	D1101304	ALIGO, SUS, UHV CONNECTOR CLAMP, JAW	6061 AL ALLOY	1	1
2	D1101303-1	ALIGO, SUS, UHV CONNECTOR CLAMP, MT. BRACKET (TABLE MT.)	6061 AL ALLOY	-	1
1	D1101303	ALIGO, SUS, UHV CONNECTOR CLAMP, MT. BRACKET	6061 AL ALLOY	1	-

PARTS LIST

NOTES AND TOLERANCES: (UNLESS OTHERWISE SPECIFIED)

LIGO CALIFORNIA INSTITUTE OF TECHNOLOGY
 MASSACHUSETTS INSTITUTE OF TECHNOLOGY

PART NAME
ALIGO, SUS, UHV CONNECTOR CLAMP ASSY.

SYSTEM
 ADVANCED LIGO

SUB-SYSTEM
 SUS

DESIGNER
 E.SANCHEZ 11 JUL 2011

DRAFTER
 E.SANCHEZ 11 JUL 2011

CHECKER

APPROVAL

SIZE DWG. NO.
 c **D1101305**

REV.
 v1

SCALE: 1:1 PROJECTION:

SHEET 1 OF 1

MATERIAL
 N/A

FINISH
 N/A μinch

NEXT ASSY
 D0901346