

- NOTES CONTINUED:
- SCRIBE, ENGRAVE, OR MECHANICALLY STAMP (NO INKS OR DYES) DRAWING PART NUMBER AND REVISION ON NOTED SURFACE FOLLOWED ON THE NEXT LINE BY A THREE DIGIT SERIAL NUMBER. SERIAL NUMBERS START AT 001 FOR THE FIRST ARTICLE AND PROCEED CONSECUTIVELY. USE 07" HIGH CHARACTERS. EXAMPLE: DXXXXXXV, S/N 001. VIBRATORY TOOL MAY BE USED.
 - APPROXIMATE WEIGHT = X.XXXX LB.
 - MACHINE ALL SURFACES TO REMOVE OXIDES AND MILL FINISH. USE OF ABRASIVE REMOVAL TECHNIQUES IS NOT ALLOWED. REFER TO LIGO-59190364
 - ALL PARTS SHALL BE MANUFACTURED IN ACCORDANCE WITH LIGO SPECIFICATION E090364.
 - ALL HELI-COIL HOLES TO BE PREPARED ACCORDING TO EMHART HELI-COIL PRODUCT CATALOG, HC2000, REV 4
 - ALL HELI-COIL INSERTS TO BE INSTALLED BY LIGO PERSONNEL. AFTER DELIVERY OF FINISHED PARTS, USE NITRONIC 40 THREADED INSERTS.
 - ALL MATERIAL IS TO BE VIRGIN MATERIAL (I.e., NO WELD REPAIRS, PLUGS OR RECYCLED MATERIAL). NO REPAIRS SHALL BE MADE UNLESS APPROVED IN ADVANCE AND IN WRITING, BY LIGO LABORATORY. REFER TO LIGO-59190364.
 - SURFACE FINISH TO BE AS-PROCESSED FROM MILL/SUPPLIER, FREE FROM SCRATCHES OR GOUGES.
 - PART WILL BE PORCELAIN COATED PER LIGO SPECIFICATION E100083. AFTER FABRICATION, THE INDICATED HOLES WILL BE MASKED PRIOR TO PORCELAIN COATING TO APPROXIMATELY 2-3X HOLE DIAMETER, CENTERED ON BOTH SIDES OF THE HOLE.
 - DIMENSIONS APPLY BEFORE PORCELAIN COATING UNLESS SPECIFIED.
 - BEND RADIUS: UNLESS OTHERWISE NOTED, THE BEND RADIUS SHOULD BE THE MINIMUM REQUIRED TO FORM WITHOUT CRACKING OR REQUIRING ADDITIONAL WORK WHEN FORMING. IN PARTICULAR IF SHEET METAL IS TO BE PORCELAIN COATED, THE BEND RADIUS SHALL BE A MINIMUM OF .12" OUTSIDE RADIUS OF BEND UNLESS OTHERWISE NOTED.

25 PIN D CONNECTOR MALE J1

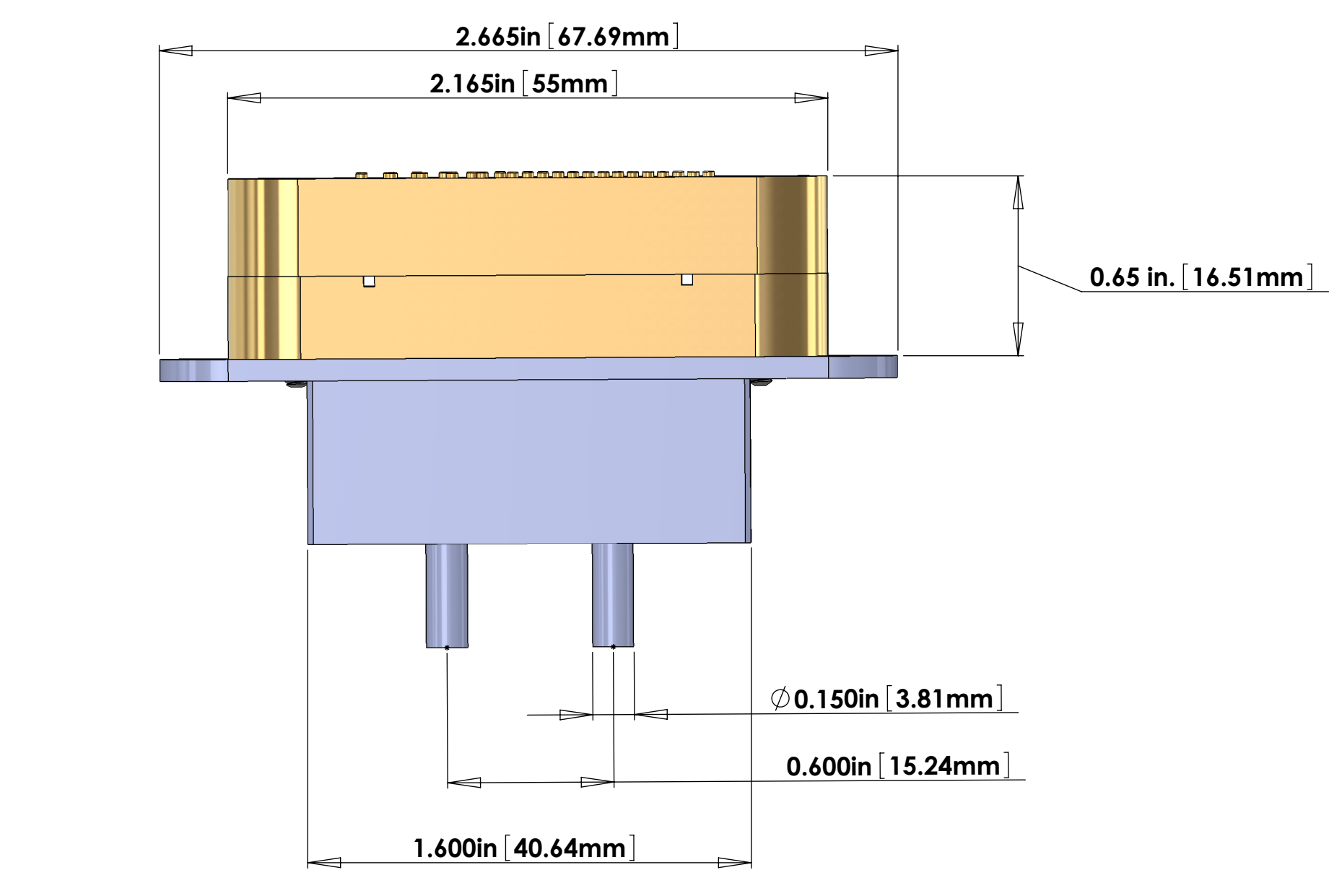

J1 GOLD METALIZED OVER ELECTRO-LESS NICKEL SELECTIVELY METALIZED PEEK

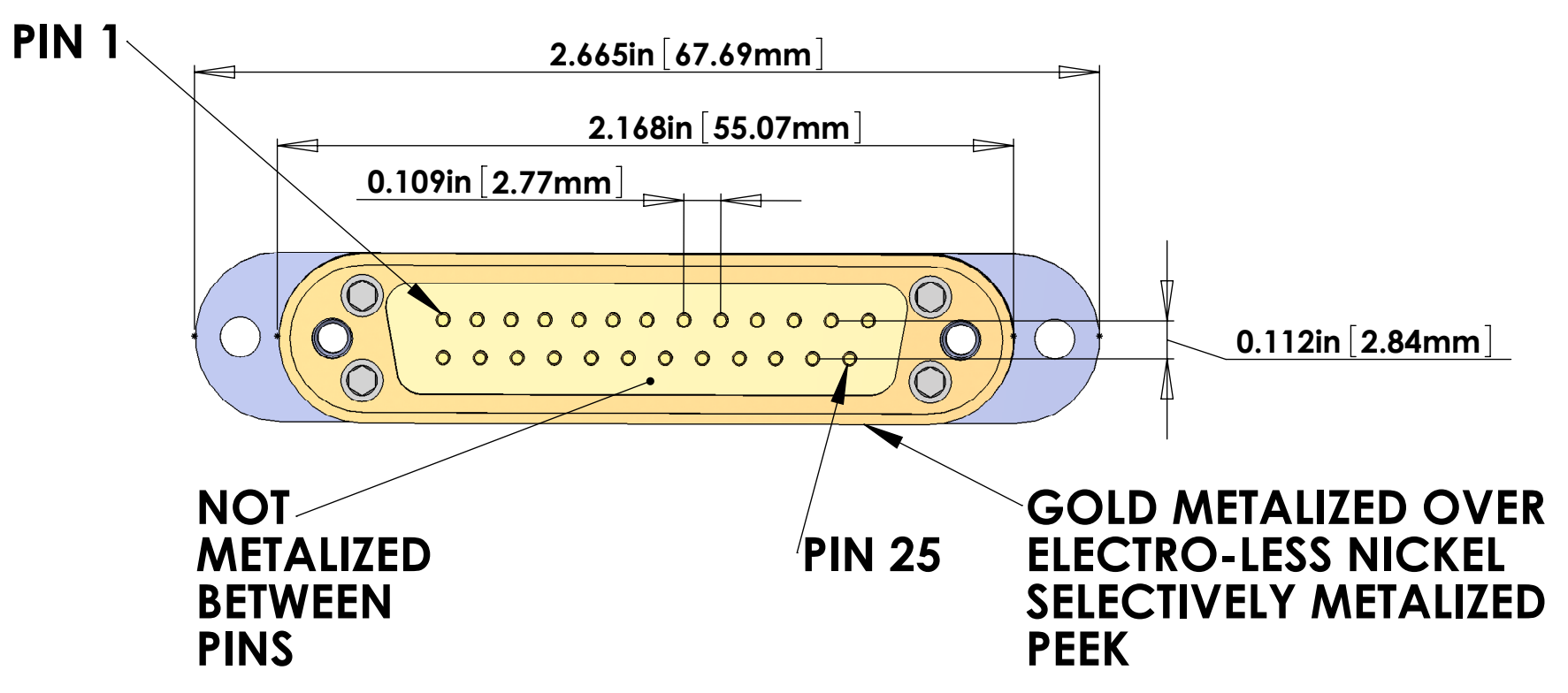
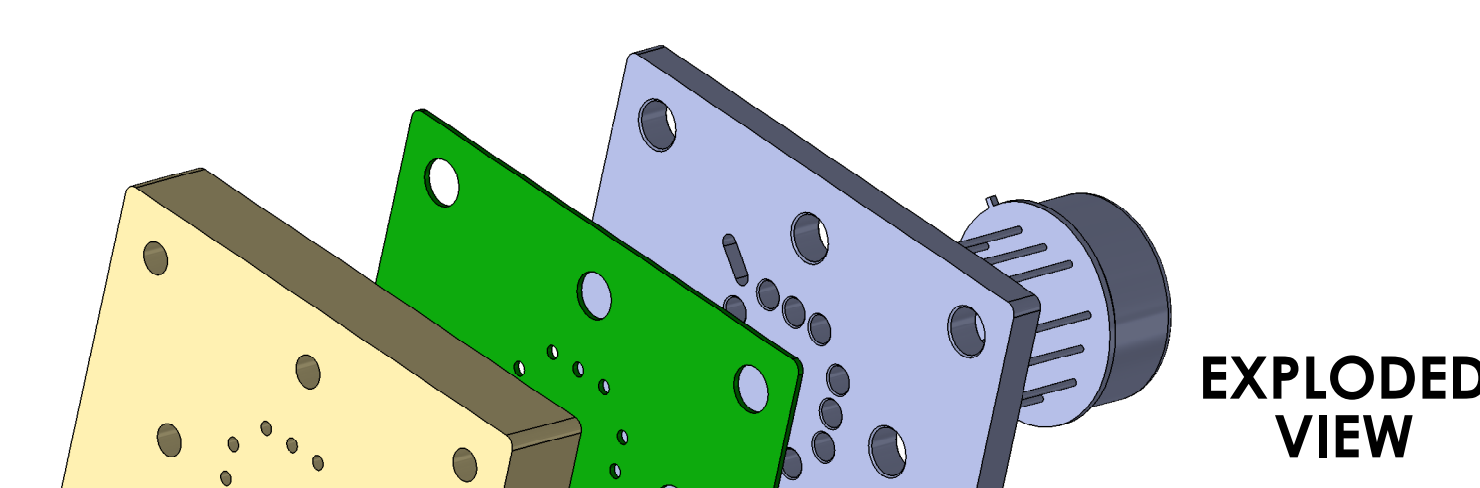
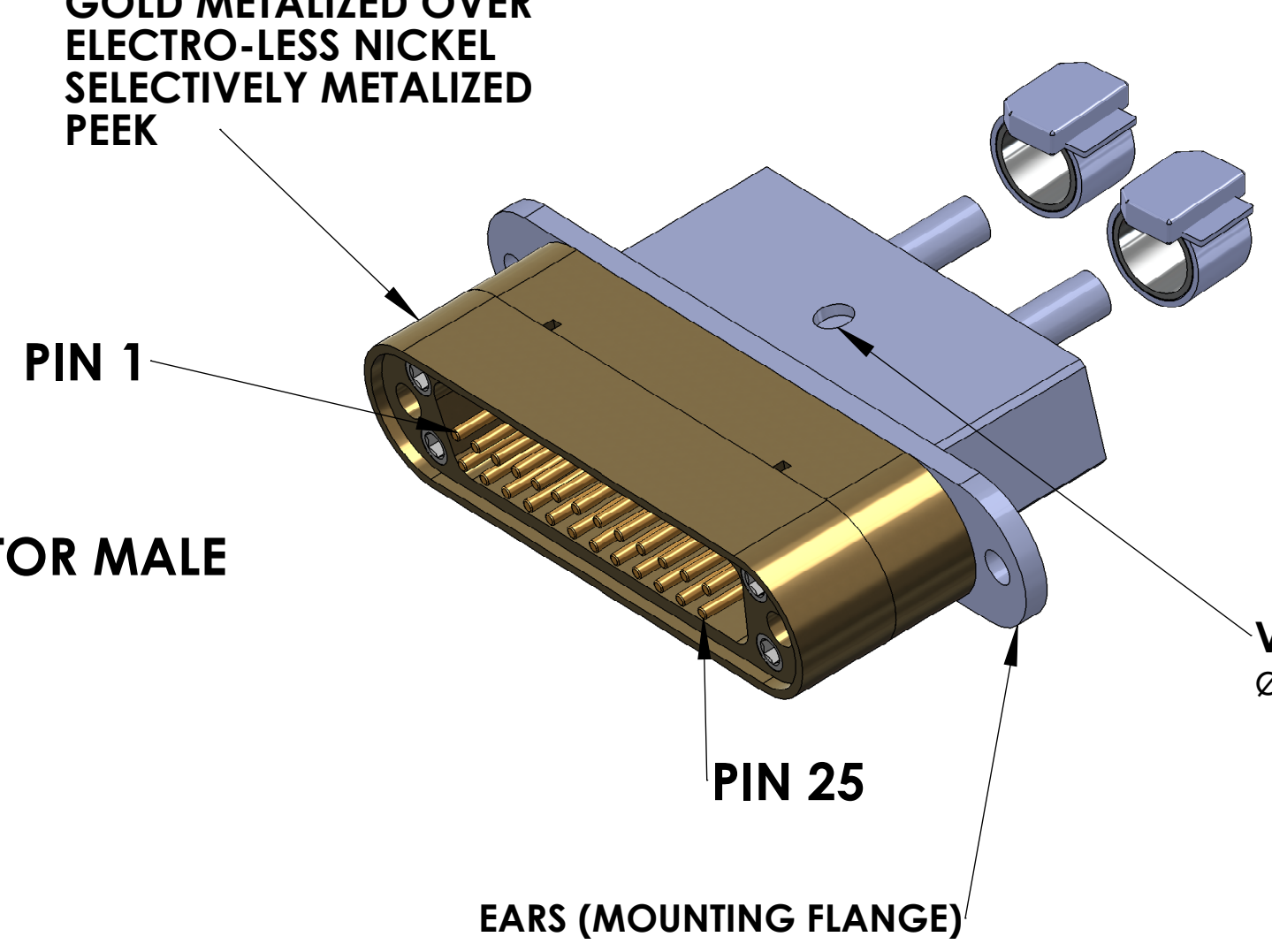

SEE DRAWING DCC#-LIGO-D1002106 FOR MOUNTING

SANDWICHED VIEW

WHEN MAKING THIS CABLE WITH PIGTAILS (WITHOUT QPD CONNECTORS ATTACHED) LEAVE 6in. EACH OF THE 6 WIRES STICKING OUT PAST THE CLAMP AND TUBE INSERT.

QPD CONNECTOR J2, J3

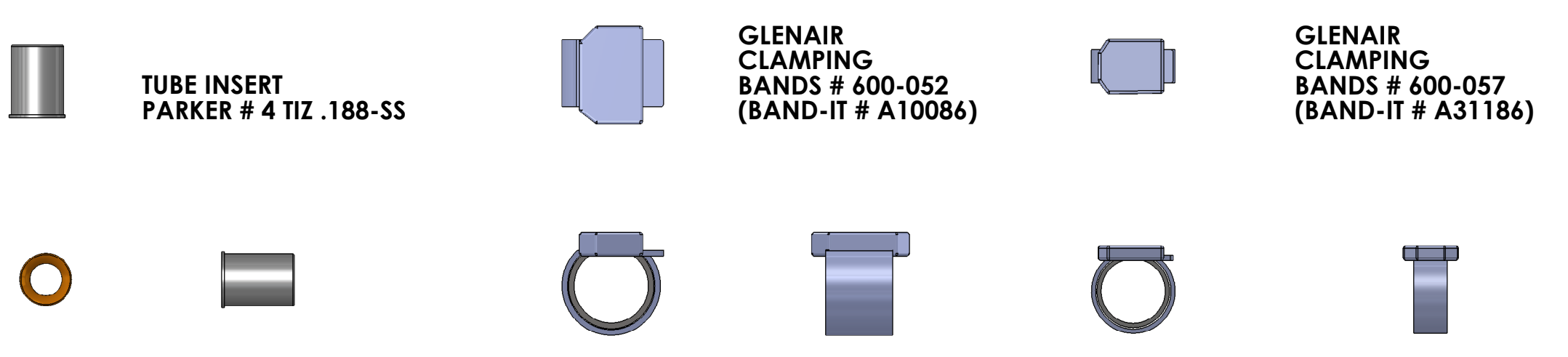
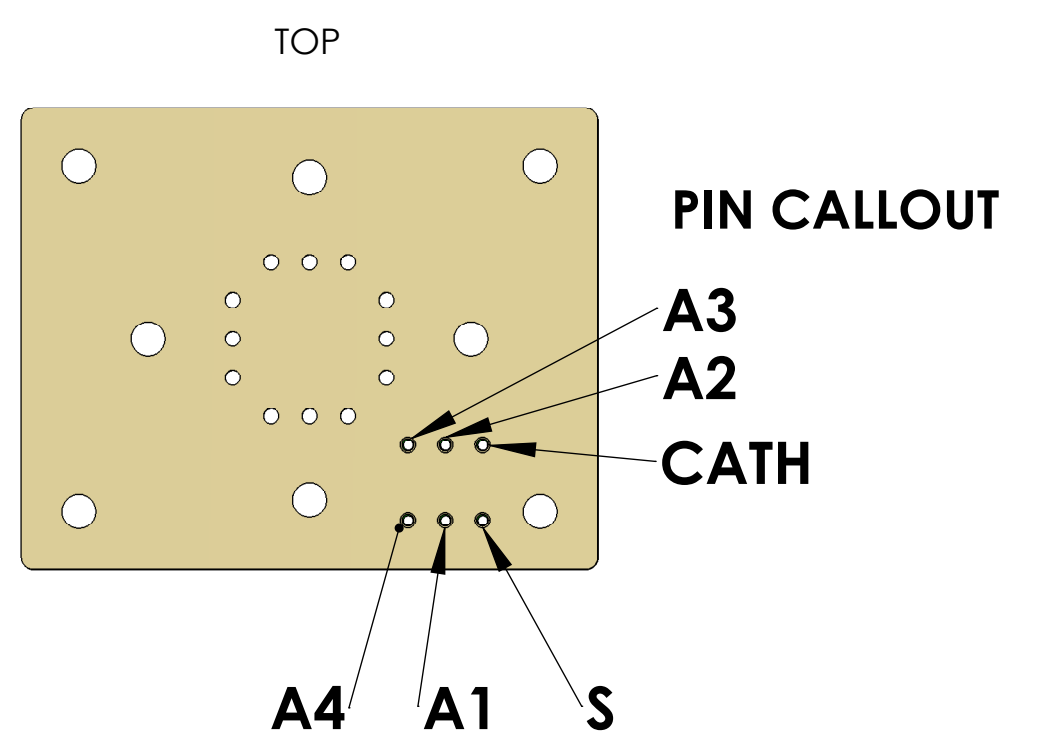
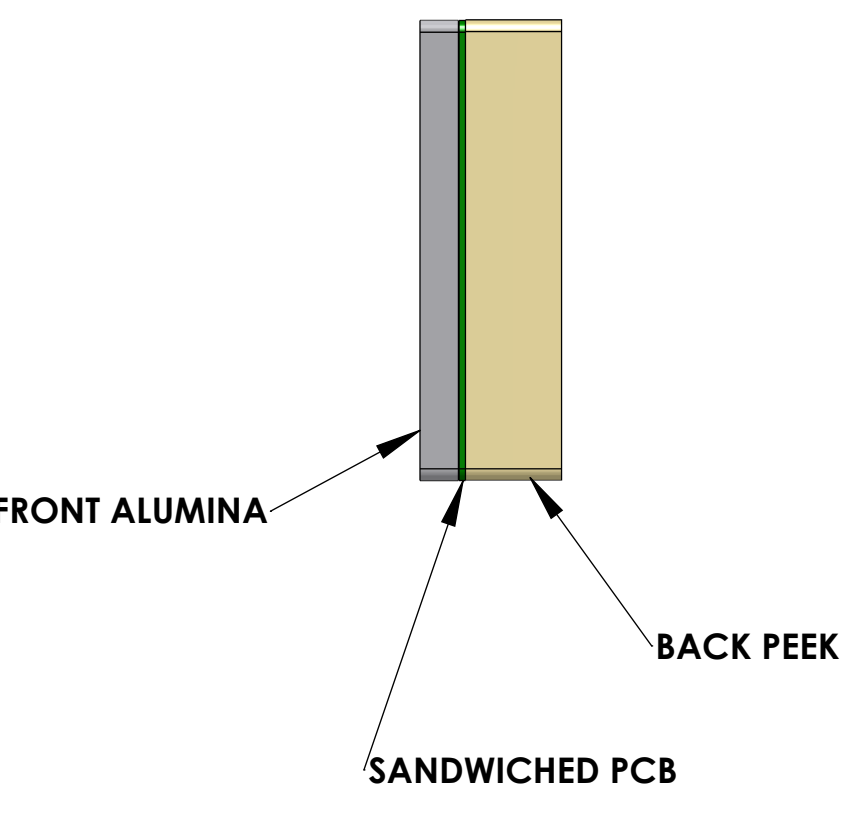
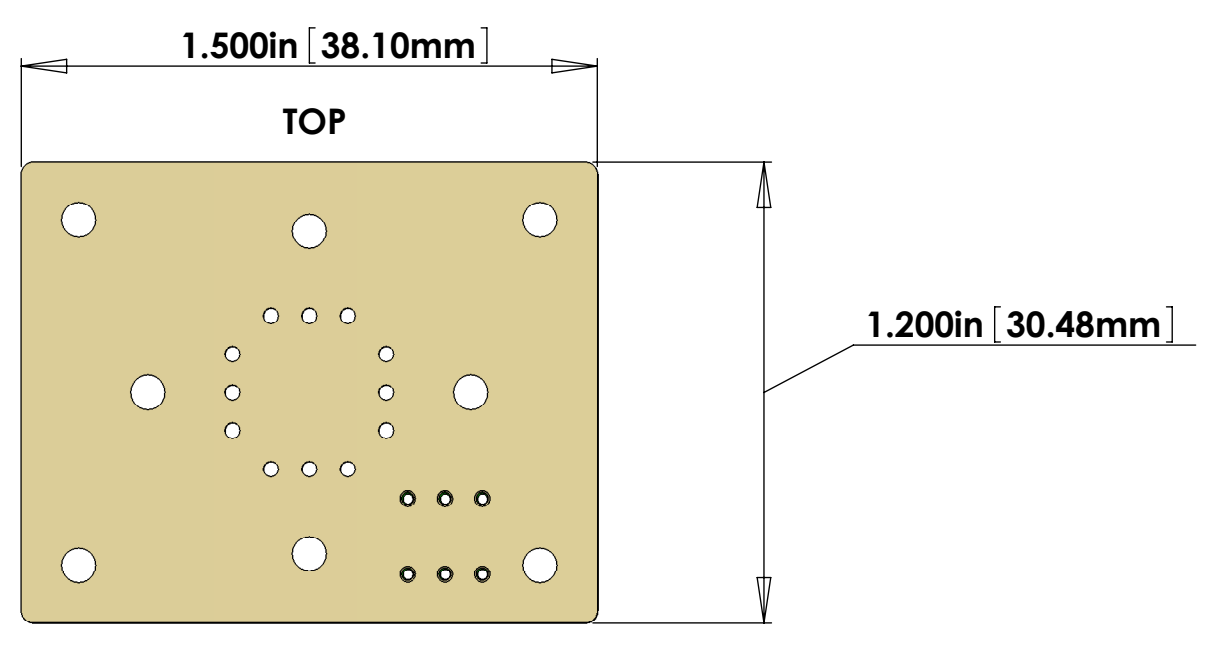
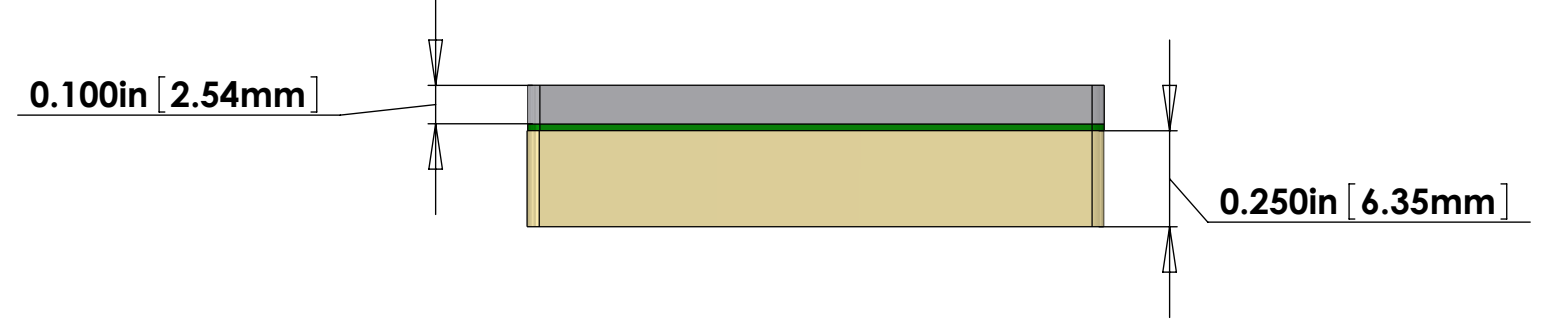

V25T CABLE ASSEMBLY CIRCUIT SUMMARY V-DB25 M/S1-40,40-2_QPD

FROM					TO			
CONNECTOR J1 - 25 PIN SUBMINI D MALE CONNECTOR SELECTIVELY METALIZED (PEEK)					CONNECTOR J2 - QPD FEMALE CONNECTOR (PEEK)			PCB CONNECTION
PIN	WIRE NAME	COLOR	LENGTH	TWISTED PAIR	PIN	WIRE NAME	SIGNAL	
1, SHELL	SHIELD (BRAID)		40 in.*		CONNECTED ONLY TO BRAID CLAMP	SHIELD (BRAID)	SHIELD	N/C
13	(CABLE 1) WIRE 13	White	40 in.*	TP-1	A4	(CABLE 1) WIRE 13	QPD 1 ANODE 4	A4
25	(CABLE 1) WIRE 25	White	40 in.*		A3	(CABLE 1) WIRE 25	QPD 1 ANODE 3	A3
12	(CABLE 1) WIRE 12	White	40 in.*	TP-2	A2	(CABLE 1) WIRE 12	QPD 1 ANODE 2	A2
24	(CABLE 1) WIRE 24	White	40 in.*		A1	(CABLE 1) WIRE 24	QPD 1 ANODE 1	A1
11	(CABLE 1) WIRE 11	White	40 in.*		S	(CABLE 1) WIRE 11	QPD 1 SENSE	S
23	(CABLE 1) WIRE 23	White	40 in.*	TP-3	CAT	(CABLE 1) WIRE 23	QPD 1 CATHODE	CAT
					CONNECTOR J3 - QPD FEMALE CONNECTOR (PEEK)			PCB CONNECTION
					PIN	WIRE NAME	SIGNAL	
1, SHELL	SHIELD (BRAID)		40 in.*		CONNECTED ONLY TO BRAID CLAMP	SHIELD (BRAID)	SHIELD	N/C
10	(CABLE 2) WIRE 10	White	40 in.*	TP-4	A4	(CABLE 2) WIRE 10	QPD 2 ANODE 4	A4
22	(CABLE 2) WIRE 22	White	40 in.*		A3	(CABLE 2) WIRE 22	QPD 2 ANODE 3	A3
9	(CABLE 2) WIRE 9	White	40 in.*	TP-5	A2	(CABLE 2) WIRE 9	QPD 2 ANODE 2	A2
21	(CABLE 2) WIRE 21	White	40 in.*		A1	(CABLE 2) WIRE 21	QPD 2 ANODE 1	A1
8	(CABLE 2) WIRE 8	White	40 in.*	TP-6	S	(CABLE 2) WIRE 8	QPD 2 SENSE	S
20	(CABLE 2) WIRE 20	White	40 in.*		CAT	(CABLE 2) WIRE 20	QPD 2 CATHODE	CAT
PIN 14,2,15,3,16,4,17,5,18,6,19,7 N/C (NOT CONNECTED)								
* USE WHATEVER LENGTH IS NECESSARY FOR THE INTERNAL WIRING OF THE CONNECTORS AND STRIP LENGTH TO ACHIEVE THE CORRECT OVERALL LENGTHS. INCLUDE NOM. 40in. LENGTH + STRIP LENGTH + INTERNAL SERVICE LOOPS + 6in. FOR PIGTAILS.								

BILL OF MATERIALS

ITEM NO.	PART NUMBER	DESCRIPTION	QTY.	LENGTH
1	CUSTOM DB25 MALE TICOR# IS0145-1 INCLUDING TICOR #'S 034-1206-2520 (1ea.), 034-1202-2520 (1ea.), 1185-04CN336 (2ea.), 013-2701-0001 (4ea) and M39029/58-363 (2ea)	DB25 MALE CONNECTOR (J1) FOR UHV - ELECTRO-LESS NICKEL SELECTIVELY METALIZED (COMPLETE CONNECTOR)	1	
2	TICOR #040-2725-2502	DB25 CONNECTOR BACKSHELL (TWO PORT) FOR UHV (STAINLESS)	1	
3		QPD FEMALE CONNECTOR (J2,J3) FOR UHV (PEEK)	2	
4	C1	6 COND. CABLE WITH COPPER BRAID (SHIELD) AND PEEK OVERBRAID INCLUDING 6 28GA. WIRES WITH CZ1105 PFA INSULATION	2	40in.* 40in.*
5	PARKER# 4 TIZ .188-SS	1/4" TUBE INSERT 1/4" LENGTH 0.188" o.d.	2	
6	GLENAIR # 600-052 or BAND-IT # A10086	GLENAIR # 600-052 STANDARD BRAID CLAMP or BAND-IT PART # A10086 (0.240" WIDE) ("BAG OF 100" # A10089)	2	
7	GLENAIR # 600-057 or BAND-IT # A31186	GLENAIR # 600-057 STANDARD BRAID CLAMP or BAND-IT PART # A31186 (0.120" WIDE) ("BAG OF 100" # A31189)	2	

* NOTE: USE WHATEVER LENGTH IS NECESSARY FOR THE INTERNAL WIRING OF THE CONNECTORS AND STRIP LENGTH TO ACHIEVE THE CORRECT OVERALL LENGTHS.

NOTES: (UNLESS OTHERWISE SPECIFIED)

- MATERIAL: a. J1 CONNECTOR SHELL - SELECTIVELY METALIZED OVER PEEK VICTREX 450GL30
b. BACKSHELL - STAINLESS STEEL WITH VENT HOLE
c. CONTACTS - BERYLLIUM COPPER ALLOY C17300 0.00050 MIN. GOLD OVER NICKEL
d. HARDWARE: CORROSION RESISTANCE STEEL, PASSIVATED
e. PEEK BRAID - PEEK VICTREX GRADE TDS-450CA30 CARBON LOADED - SUPPLIED BY LIGO
- CABLE 6 COND. 28 AWG (40 STRD 44 AWG) WITH PFA INSULATION COONER WIRE # CZ1105 OVERALL 40AWG COPPER BRAID 90% COVERAGE - SUPPLIED BY LIGO OVERALL PEEK BRAID MIN. 50% COVERAGE - SUPPLIED BY LIGO OVERALL CABLE O.D. WILL BE APPROX. 0.240 IN.
- CONNECTORS WILL BE SUPPLIED WITH HARDWARE. LENGTH OF SCREWS AS SHOWN ARE APPROXIMATE SCREWS SHOULD BE THE PROPER LENGTH FOR PROPER MATING

V-DB25 M/S1-40,40-2_QPD STANDARD USE FOR THIS CABLE

SUBSYSTEM	AIR/VAC	STANDARD USE
ISC	IN-VAC	QPD'S FOR TRANSMON

NOTES AND TOLERANCES: (UNLESS OTHERWISE SPECIFIED)

DIMENSIONS ARE IN INCHES

TOLERANCES: .XX ± .XXX ±

ANGULAR ± °

NOTES AND TOLERANCES: (UNLESS OTHERWISE SPECIFIED)

- INTERPRET DRAWING PER ASME Y14.5-1994
- REMOVE ALL SHARP EDGES. .005-.015. FOR MACHINED PARTS. ROUND ALL EDGES APPROXIMATELY R.02 FOR SHEET METAL PARTS.
- DO NOT SCALE FROM DRAWING.
- ALL MACHINING FLUIDS MUST BE FULLY SYNTHETIC, FULLY WATER SOLUBLE AND FREE OF SULFUR, SILICONE, AND CHLORINE.

MATERIAL: Material <not specified>

FINISH: μinch

SYSTEM: CALIFORNIA INSTITUTE OF TECHNOLOGY MASSACHUSETTS INSTITUTE OF TECHNOLOGY

SUB-SYSTEM: ISC

NEXT ASSY:

PART NAME: CUSTOM CABLE SPECIFICATION V25T-40

DESIGNER: R. ABBOTT

DRAFTER: E. BROWN

CHECKER:

APPROVAL:

DATE: OCT/03/2011

SIZE: DWG. NO. E D1101654

SCALE: 2:1

PROJECTION:

REV. v3

SHEET 1 OF 1