

NOTES CONTINUED:

5. SCRIBE, ENGRAVE, LASER MARK OR MECHANICALLY STAMP (NO DYES OR INKS) A UNIQUE THREE DIGIT SERIAL NUMBER & REVISION NUMBER ON EACH PART. SERIAL NUMBERS START AT 001 FOR THE FIRST ARTICLE AND PROCEED CONSECUTIVELY. BAG AND TAG PARTS WITH THEIR DRAWING PART NUMBER, REVISION, VARIANT OR "TYPE" (IF APPLICABLE), AND QUANTITY. IF PARTS ARE TOO SMALL TO SCRIBE, BAGGING AND TAGGING ALONE IS SUFFICIENT.
 EXAMPLE (PART): 001-v1
 EXAMPLE (TAG): DXXXXXX-VY, TYPE-XX, QTY: TBD

6. APPROXIMATE WEIGHT = 1.13 LB.

7. MACHINE ALL SURFACES TO REMOVE OXIDES AND MILL FINISH. USE OF ABRASIVE REMOVAL TECHNIQUES IS NOT ALLOWED. REFER TO LIGO-E0900364

8. ALL PARTS SHALL BE MANUFACTURED IN ACCORDANCE WITH LIGO SPECIFICATION E0900364.

9. ALL MATERIAL IS TO BE VIRGIN MATERIAL (i.e. NO WELD REPAIRS, PLUGS OR RECYCLED MATERIAL). NO REPAIRS SHALL BE MADE UNLESS APPROVED IN ADVANCE, AND IN WRITING, BY LIGO LABORATORY. REFER TO LIGO-E0900364.

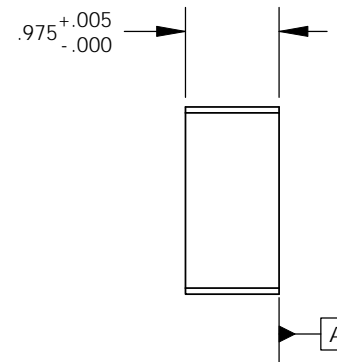
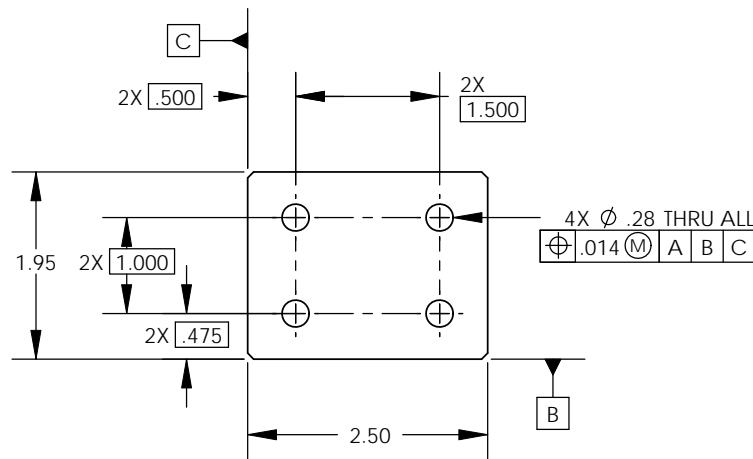
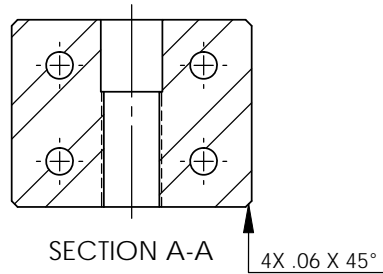
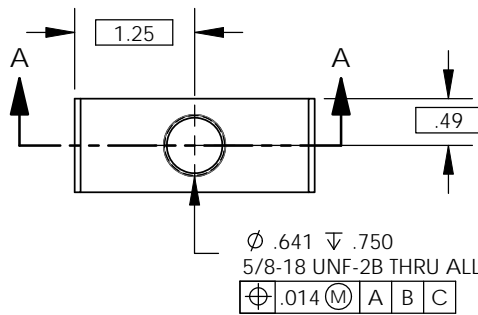

NOTES AND TOLERANCES: (UNLESS OTHERWISE SPECIFIED)

DIMENSIONS ARE IN INCHES

TOLERANCES:

XX ± .01
XXX ± .005

ANGULAR ± 0.5°

- INTERPRET DRAWING PER ASME Y14.5-1994.
- REMOVE ALL SHARP EDGES: .005-.015. FOR MACHINED PARTS. ROUND ALL EDGES APPROXIMATELY R.02 FOR SHEET METAL PARTS.
- DO NOT SCALE FROM DRAWING.
- ALL MACHINING FLUIDS MUST BE FULLY SYNTHETIC, FULLY WATER SOLUBLE AND FREE OF SULFUR, SILICONE, AND CHLORINE.

MATERIAL

Nitronic 60

FINISH

63 μin/ch



CALIFORNIA INSTITUTE OF TECHNOLOGY
MASSACHUSETTS INSTITUTE OF TECHNOLOGY

SYSTEM

ADVANCED LIGO

SUB-SYSTEM

AOS

NEXT ASSY

D1101939

PART NAME

ALIGO, AOS, VIEWPORT LEAK TEST FIXTURE, THREADED LEAD SCREW MT. BLOCK

DESIGNER

J.LEWIS

07 OCT 2011

DRAFTER

E.SANCHEZ

11 OCT 2011

CHECKER

SEE DCC

SEE DCC

APPROVAL

SEE DCC

SEE DCC

SIZE

A

DWG. NO.

D1101934

REV.

v1

SCALE: 1:2

PROJECTION:



SHEET 1 OF 1