

NOTES CONTINUED:

5. BAG AND TAG INDIVIDUAL PARTS WITH THE PARTNUMBER, REVISION NUMBER AND UNIQUE THREE DIGIT SERIAL NUMBER. SERIAL NUMBERS START AT 001 FOR THE FIRST ARTICLE AND PROCEED CONSECUTIVELY.

EXAMPLE:

D1102209-V1-001

6. APPROXIMATE WEIGHT = 0.028 LB.

REV.	DATE	DCN #	DRAWING TREE #
V3	-	-	-
-	-	-	-
-	-	-	-

60/40 OPTICAL FINISH

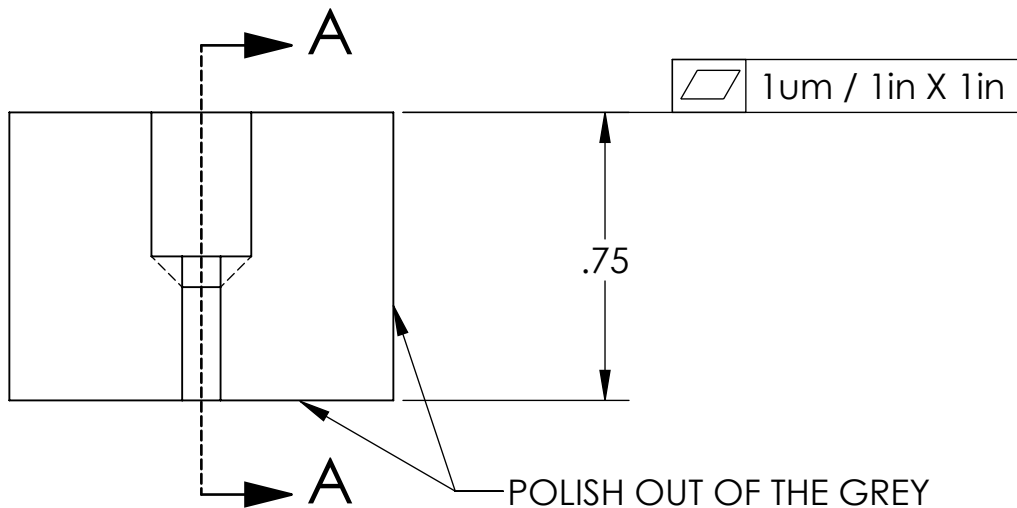
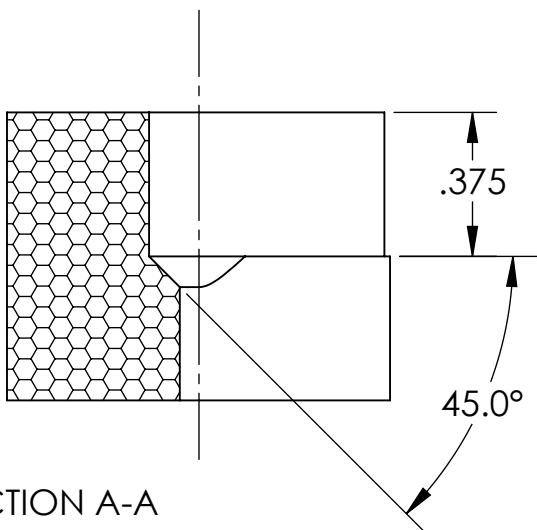
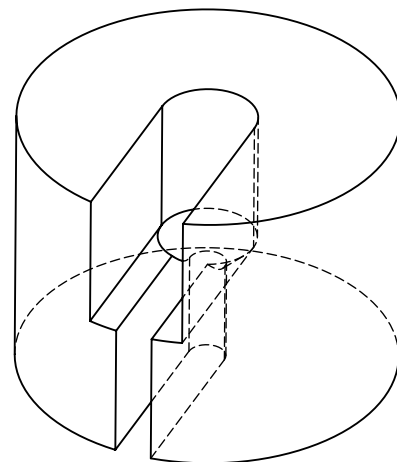
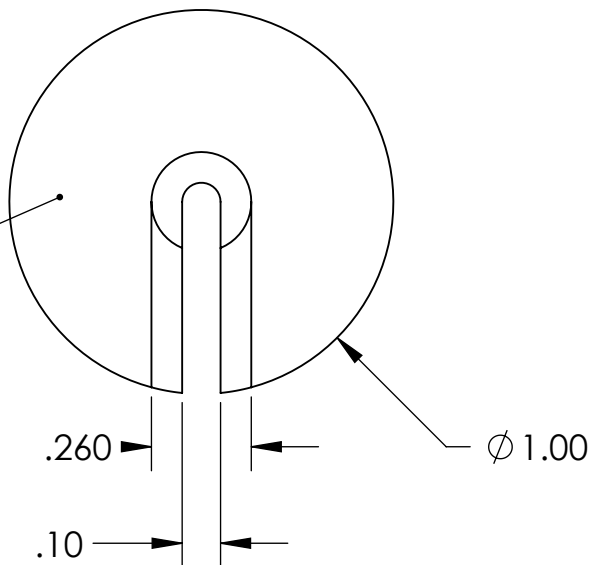

NOTES AND TOLERANCES: (UNLESS OTHERWISE SPECIFIED)

DIMENSIONS ARE IN INCHES [MM]

TOLERANCES:

.XX ± .01
.XXX ± .005

ANGULAR ± 0.5°

1. INTERPRET DRAWING PER ASME Y14.5-1994.
2. REMOVE ALL SHARP EDGES: .005-.015. FOR MACHINED PARTS. ROUND ALL EDGES APPROXIMATELY R.02 FOR SHEET METAL PARTS.
3. DO NOT SCALE FROM DRAWING.
4. ALL MACHINING FLUIDS MUST BE FULLY SYNTHETIC, FULLY WATER SOLUBLE AND FREE OF SULFUR, SILICONE, AND CHLORINE.

MATERIAL

Fused Silica

FINISH

See Notes



CALIFORNIA INSTITUTE OF TECHNOLOGY
MASSACHUSETTS INSTITUTE OF TECHNOLOGY

SYSTEM

ADVANCED LIGO

SUB-SYSTEM

ISC

NEXT ASSY

D1101965

PART NAME

aLIGO OMC Mounting Bracket

DESIGNER

SBARNUM 20 Dec 2011

DRAFTER

SBARNUM 20 Dec 2011

CHECKER

SWALDMAN

APPROVAL

PFRITCHEL

SIZE

A

DWG. NO.

D1102209 Cone v3

REV.

v3

SCALE: 2:1

PROJECTION:



SHEET 1 OF 1