

8 7 6 5 4 3 2 1

- NOTES CONTINUED:**
- BAG AND TAG PARTS SEPARATELY WITH THEIR DRAWING PART NUMBER, REVISION, AND SERIAL NUMBER. SERIAL NUMBERS START AT 001 (UNLESS OTHERWISE SPECIFIED) FOR THE FIRST ARTICLE AND PROCEED CONSECUTIVELY.
EXAMPLE:
DXXXXXX-vY
S/N-001
 - MASS: APPROX. 86 LBS.
 - CYLINDER MASSES ARE SHOWN IN SUGGESTED POSITION PER CALCULATED MASS PROPERTIES OF TELESCOPE ASSEMBLY.

REV.	DATE	DCN #	BOM #
v1	06 APR 2012	E1101152	E1101161-v1
v9	20 JUN 2013	E1300559-x0	-
-	-	-	-

D
C
B
A

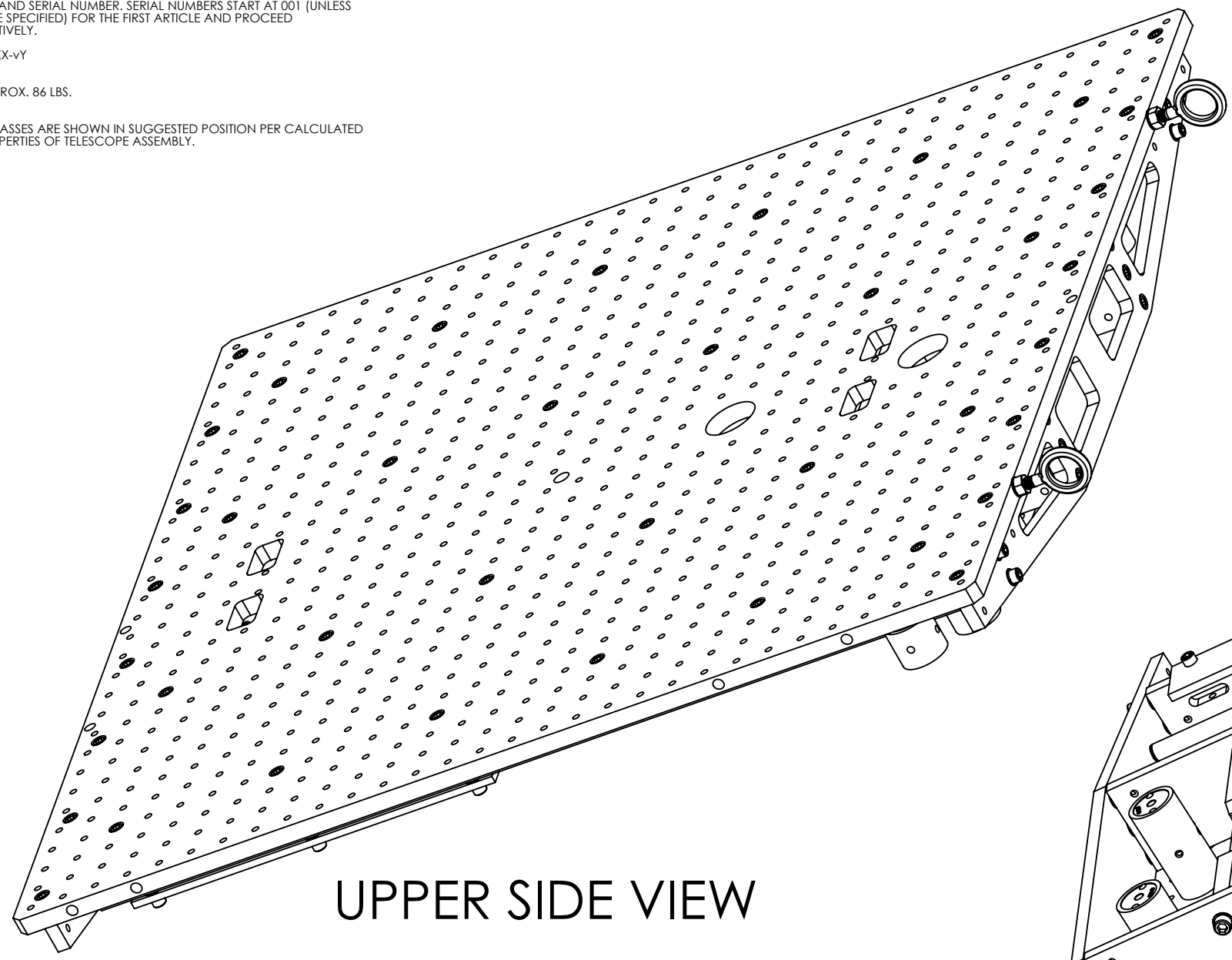

UPPER SIDE VIEW

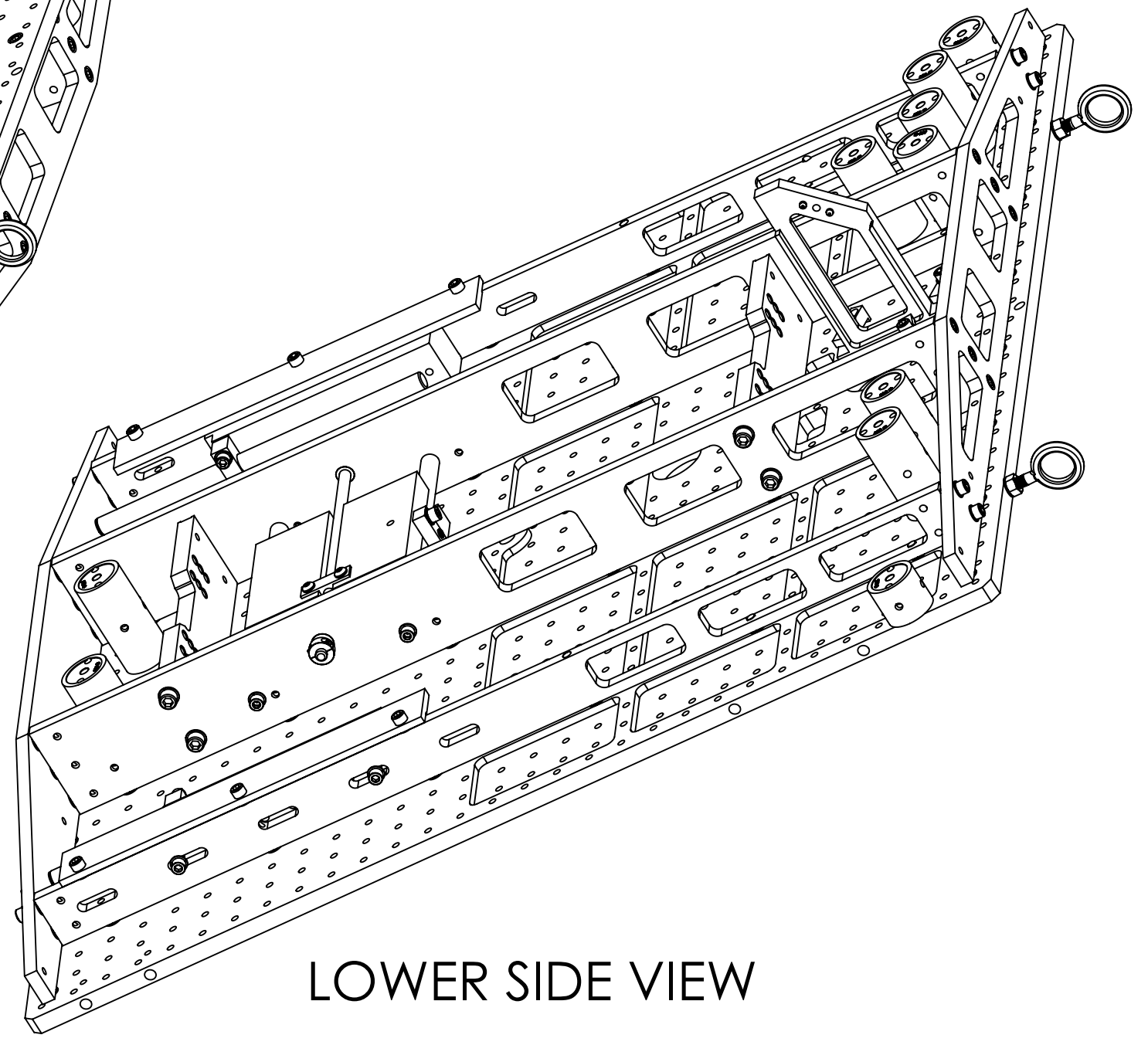

LOWER SIDE VIEW

D
C
B
A

D1102291 aLIGO TMS ISC Table Structural Assembly, PART PDM REV: X-063, DRAWING PDM REV: X-020

NOTES AND TOLERANCES: (UNLESS OTHERWISE SPECIFIED)				LIGO CALIFORNIA INSTITUTE OF TECHNOLOGY MASSACHUSETTS INSTITUTE OF TECHNOLOGY		PART NAME																	
MATERIAL		FINISH		NEXT ASSY		SYSTEM		SUB-SYSTEM		DESIGNER		DRAFTER		CHECKER		APPROVAL		SIZE		DWG. NO.		REV.	
N/A		N/A		D1000484		ADVANCED LIGO		AOS		K. MAILAND		C. CONLEY		SEE DCN		SEE DCN		B		D1102291		v9	
												SCALE: NONE		PROJECTION:		SHEET 1 OF 9							

8 7 6 5 4 3 2 1

D

C

B

A

D

C



B

A

20	99934A760 McMASTER-CARR OR EQ.	SKT SET SCRW, 1/4-20 X 3/8 L, SILVER TIP	1
19	-	SCREW, SHC, 1/4-20 X 1.0 LG., Ag PLATED	4
18	C-2012-NA UC COMPONENTS OR EQ.	SCREW, SHC, 1/4-20 X .75 LG., Ag PLATED	6
17	D1002759	αLIGO TMS TELESCOPE ROLL LOCK	1
16	D1002698	αLIGO TMS TELESCOPE ROLL SLIDE MASS	1
15	C-2012-A UC COMPONENTS OR EQ.	1/4"-20 X 0.75" SHCS, VENTED, SILVER PLATED	4
14	D1002755	αLIGO TMS TELESCOPE ROLL SLIDE ROD	2
13	D1102292	αLIGO ETM TELESCOPE BRIDGE SUPPORT TEE PLATE, BACK	1
12	D1002696	αLIGO ETM TELESCOPE BRIDGE SUPPORT TEE PLATE, FRONT	1
11	D1001164	αLIGO OPTICS TABLE GUSSET PLATE, SMALL	2
10	D1200310	αLIGO OPTICS TABLE SPEADER BRIDGE	2
9	WFV-10 UC COMPONENTS OR EQ.	WSHER, FLAT, #10, VENTED	2
8	WFV-31 UC COMPONENTS OR EQ.	WASHER, FLAT, 5/16, VENTED	12
7	WFV-25 UC COMPONENTS OR EQ.	WASHER, FLAT, 1/4, VENTED	95
6	-	SCREW, SOCKET HEAD CAP, 1/4-20 UNC-2A X 0.5 LONG	12
5	-	SCREW, SOCKET HEAD CAP, 1/4-20 UNC-2A X 0.75 LONG	11
4	C-1814-N UC COMPONENTS OR EQ.	SCREW, SOCKET HEAD CAP, 5/16-18 UNC-2A X 0.875 LONG	8
3	C-2010-N UC COMPONENTS OR EQ.	SCREW, SOCKET HEAD CAP, 1/4-20 UNC-2A X 0.625 LONG	46
2	D1001163	αLIGO OPTICS TABLE GUSSET PLATE, LARGE	2
1	D1102293	αLIGO ETM OPTICAL TABLE	1
ITEM NO.	PART NUMBER	DESCRIPTION	QTY.
PARTS LIST			

39	C-406-NA UC COMPONENTS OR EQ.	SCREW, SHC, #4-40 X .38 LG., Ag PLATED	2
38	C-404-NA UC COMPONENTS OR EQ.	SCREW, SHC, #4-40 X .25 LG., Ag PLATED	4
37	D1002504	TMS, SISKIYOU MOUNT BRACKET, LOWER OUTBOARD	1
36	D1100904	αLigo_TMS_Periscope_Mount_Clamp	3
35	D1200471	αLIGO TMS OPTICS TABLE SMALL CYLINDER MASS	2
34	D1100358	TMS TELESCOPE MASS ATTACHMENT SCREW	10
33	D1200470	αLIGO TMS OPTICS TABLE CYLINDER MASS	8
32	D1100989	NICKEL-COPPER ALLOY 400 .312-18 HEX NUT, MODIFIED	2
31	D1001161	αLIGO OPTICS TABLE TOP MODIFIED EYEBOLT	2
30	9421T300 McMASTER-CARR OR EQ.	1/4" ID SHAFT COLLAR	2
29	D1003162	αLIGO TMS TELESCOPE PITCH MASS ADJ. ROD	2
28	D1002757	αLIGO TMS TELESCOPE PITCH SLIDE BKT.	2
27	D1002699	αLIGO PITCH SLIDE MASS	2
26	D1002758	αLIGO TMS TELESCOPE PITCH GUIDE	2
25	BU-2406-NA UC COMPONENTS OR EQ.	BUTTON HEAD SOCKET SCREW 10-24 X 3/8	2
24	D1002769	αLIGO TMS TELESCOPE ROLL SLIDE BKT.	1
23	60705K46 McMASTER-CARR OR EQ.	THREADED COLLAR, CLAMP ON 5/16"-18 UNC, 11/16" OD, 9/32" WIDTH	2
22	D1201364	SHAFT GUIDE BUSHING	2
21	D1002768	αLIGO TMS TELESCOPE ROLL MASS ADJ. ROD	1
ITEM NO.	PART NUMBER	DESCRIPTION	QTY.
PARTS LIST			

D1102291 αLIGO TMS ISC Table Structural Assembly, PART PDM REV: X-063, DRAWING PDM REV: X-020

 CALIFORNIA INSTITUTE OF TECHNOLOGY
 MASSACHUSETTS INSTITUTE OF TECHNOLOGY
 SIZE DWG. NO. **B** D1102291 REV. **v9**
 SCALE: NONE PROJECTION:  SHEET 2 OF 9

TMS BREADBOARD HOLE TABULATION

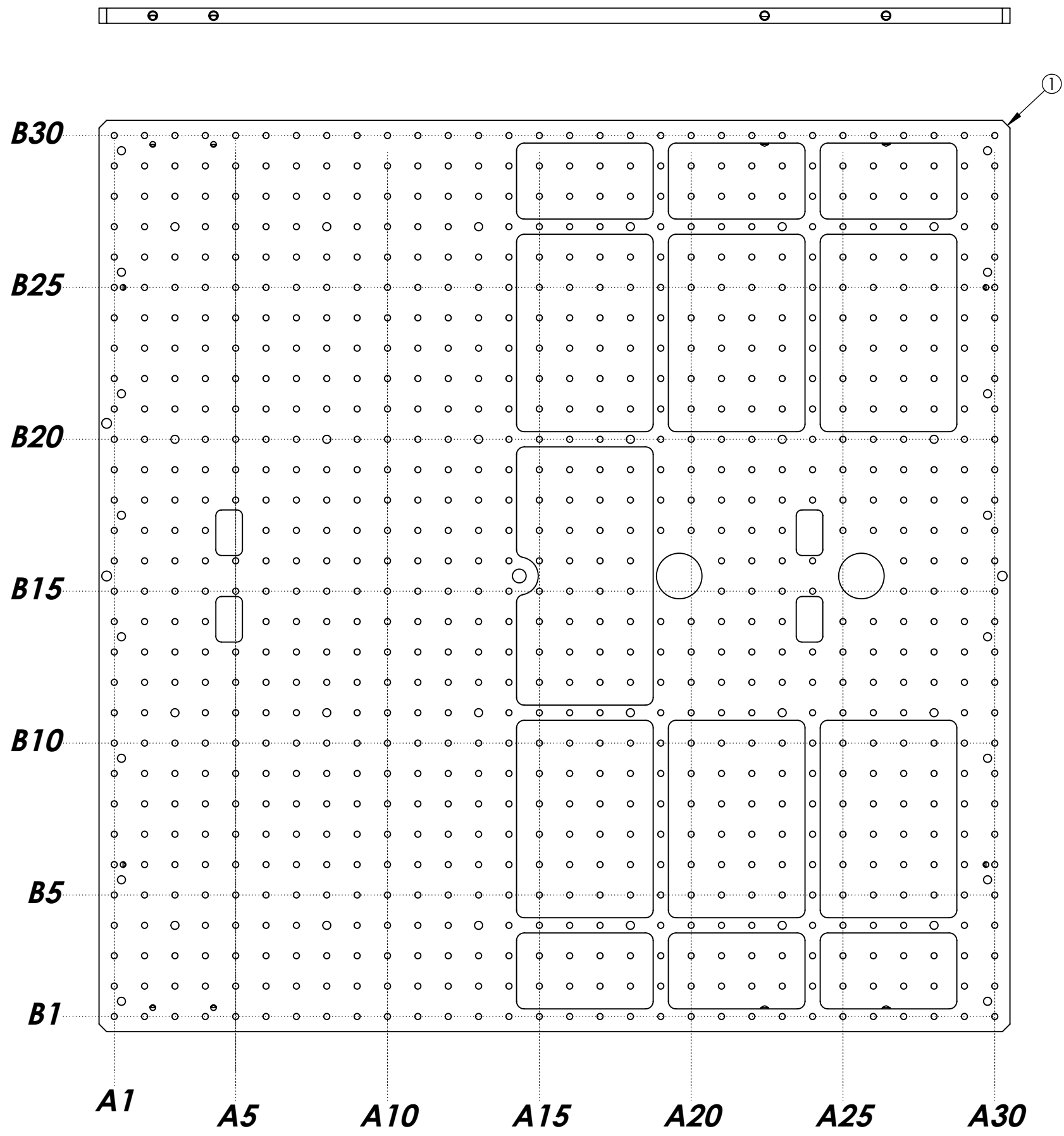

BOTTOM VIEW

D1102291 aLIGO TMS ISC Table Structural Assembly, PART PDM REV: X-063, DRAWING PDM REV: X-020

 CALIFORNIA INSTITUTE OF TECHNOLOGY MASSACHUSETTS INSTITUTE OF TECHNOLOGY		
SIZE	DWG. NO.	REV.
B	D1102291	v9
SCALE: 1:4	PROJECTION:	SHEET 3 OF 9

④ PRESS FIT NICKEL PLATED DRILL BRUSHING AS SHOWN.

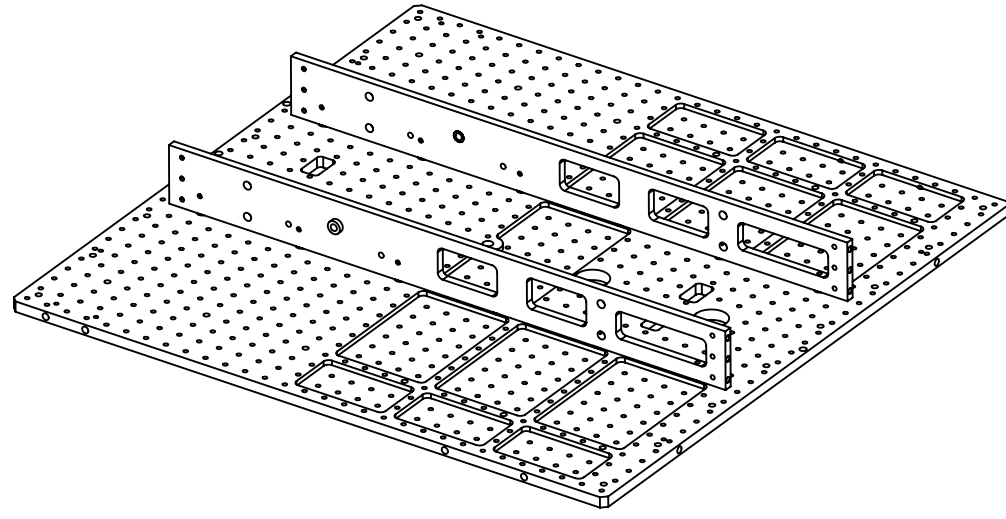

ISO VIEW - ASSEMBLED
(FOR REFERENCE ONLY)

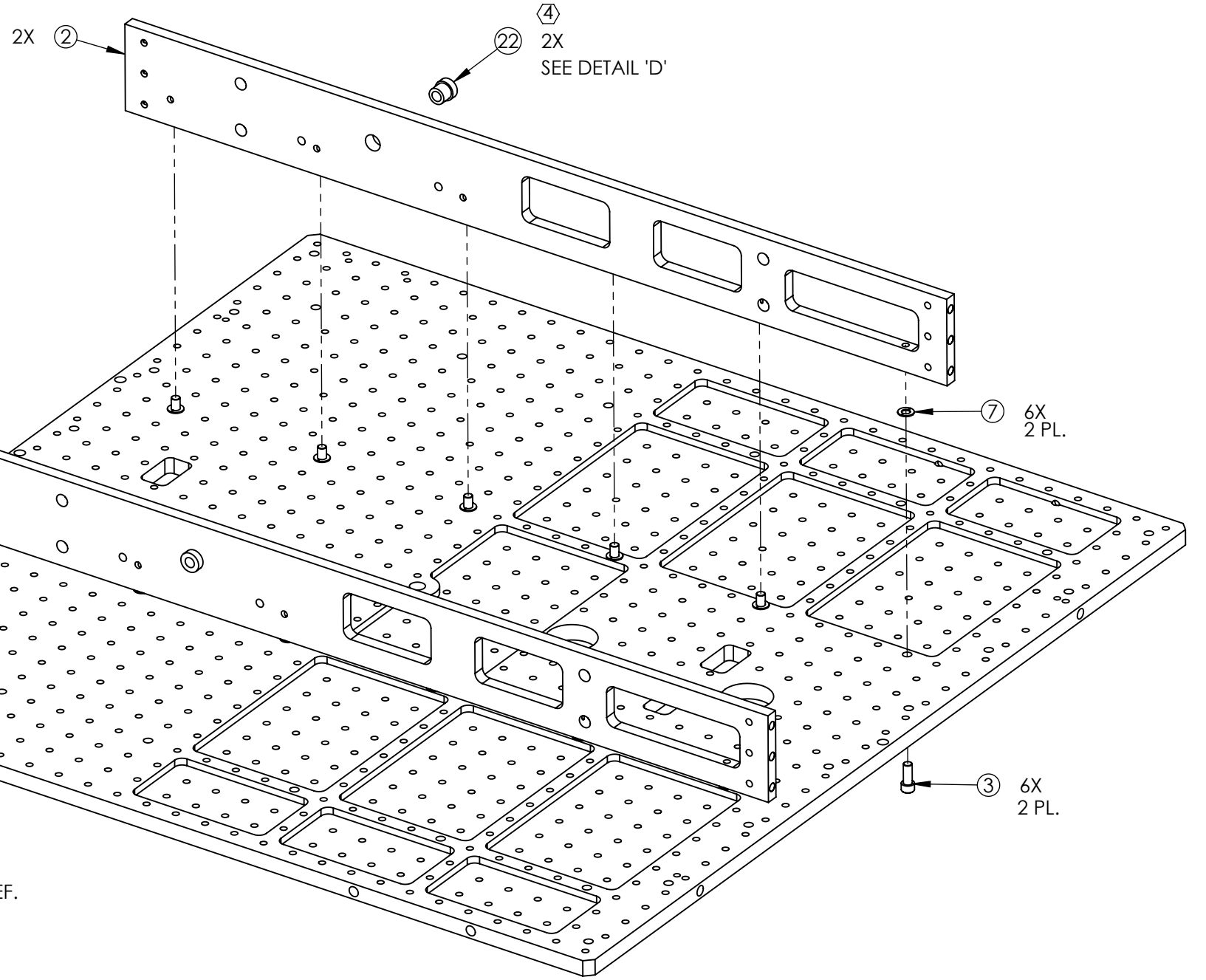

ASSY. STEP 1

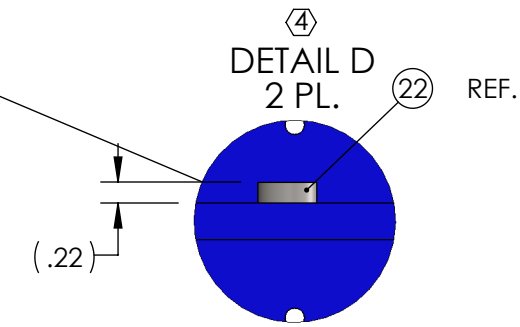
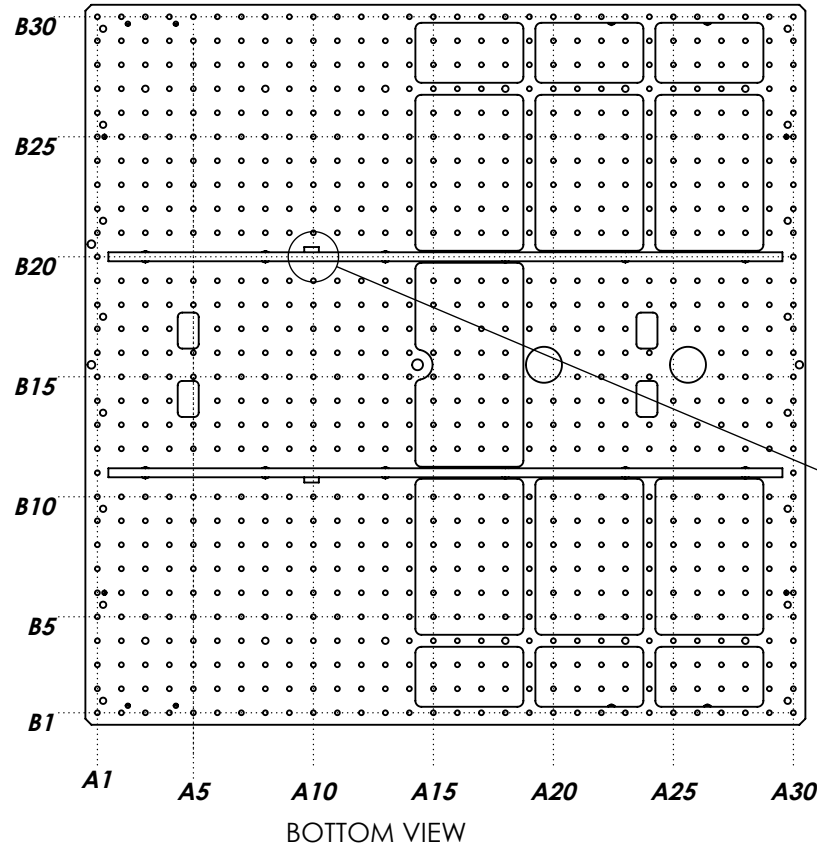

D1102291 dLIGO TMS ISC Table Structural Assembly, PART PDM REV: X-063, DRAWING PDM REV: X-020

LIGO CALIFORNIA INSTITUTE OF TECHNOLOGY MASSACHUSETTS INSTITUTE OF TECHNOLOGY	
SIZE DWG. NO. B	D1102291
SCALE: 1:4	PROJECTION:
REV. v9	SHEET 4 OF 9

⑤ ADJUST FOR FREE SHAFT ROTATION WITH MINIMUM END PLAY.

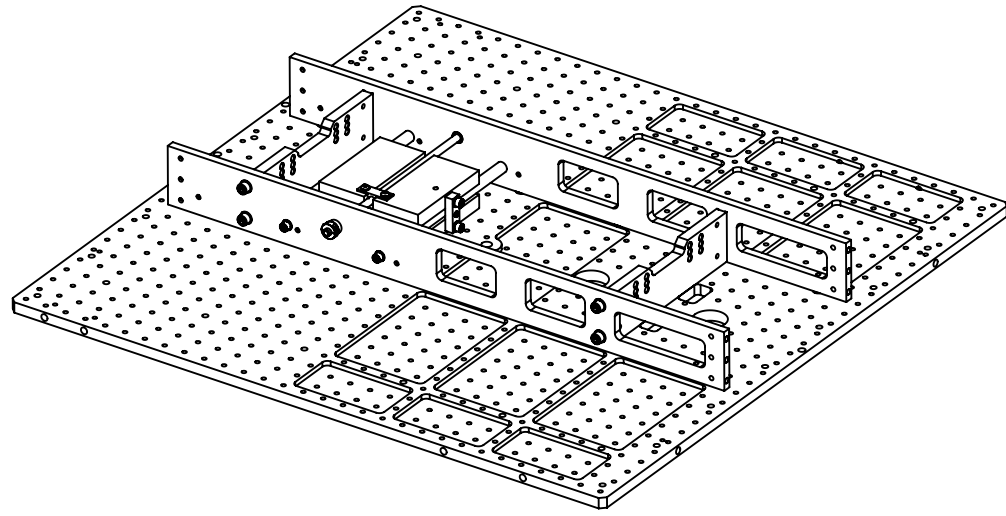

ISO VIEW - ASSEMBLED
(FOR REFERENCE ONLY)

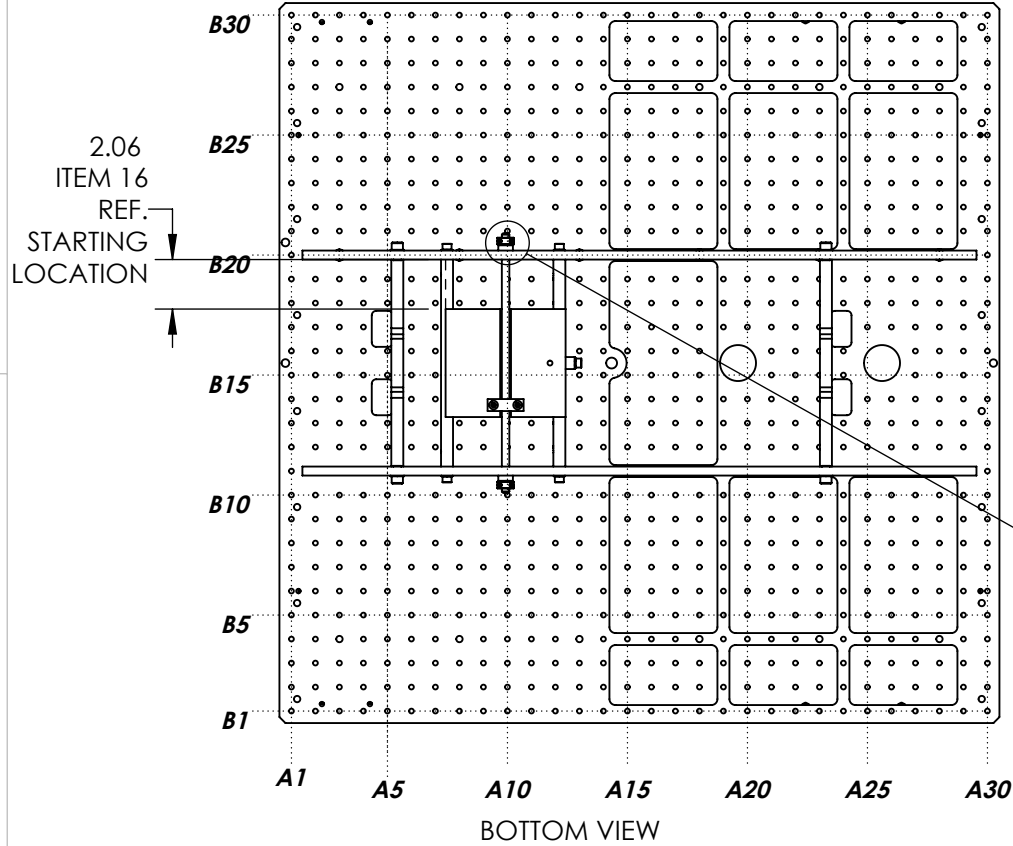

BOTTOM VIEW

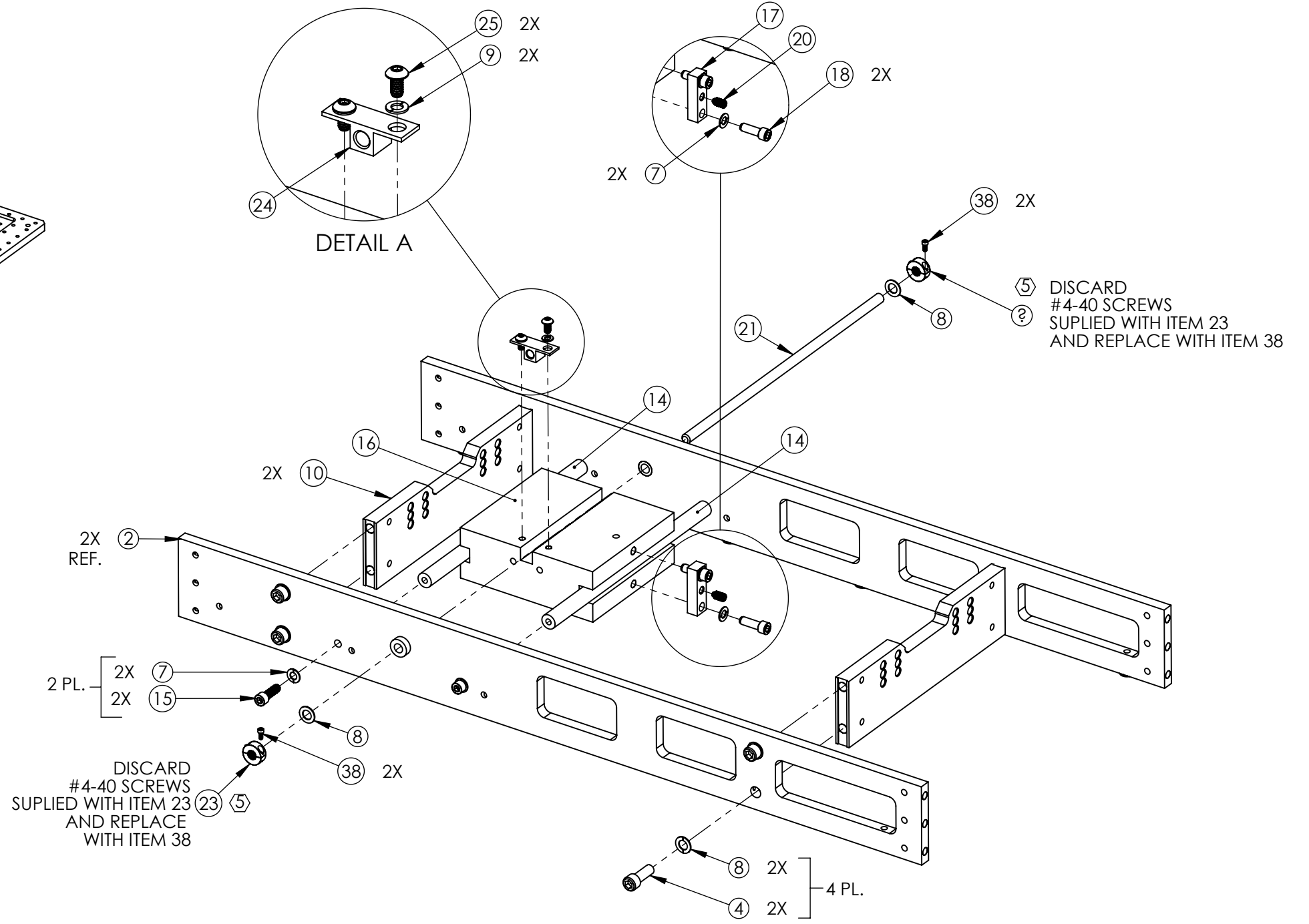

ASSY. STEP 2
(TMS TELESCOPE BREADBOARD, NOT SHOWN FOR CLARITY)

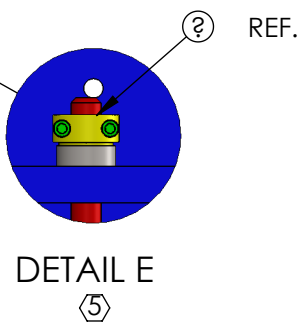

DETAIL E
⑤

D1102291 dLIGO TMS ISC Table Structural Assembly, PART PDM REV: X-063, DRAWING PDM REV: X-020

8 7 6 5 4 3 2 1

⑥ DO NOT CLAMP ITEM 26 TO BIND ADJUSTMENT OF ITEM 27. TIGHTEN ITEM 26 WHEN FINAL MASS LOCATION IS SET.

D

C

B

A

D

C

B

A

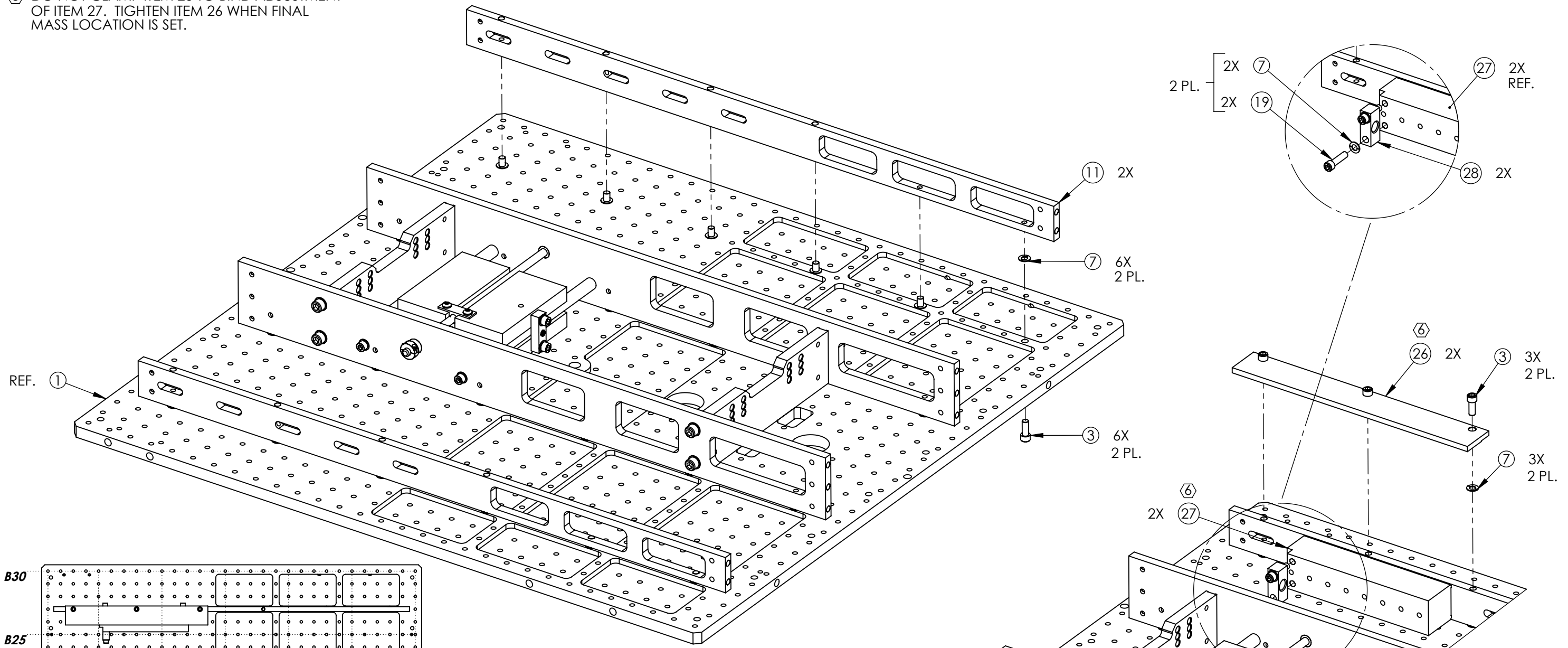

ASSY. STEP 3

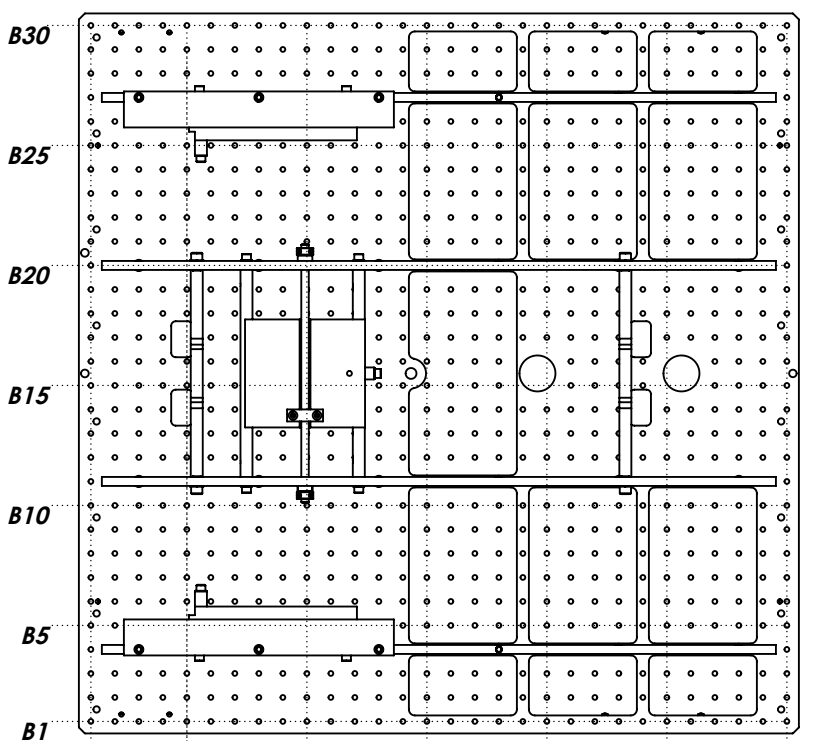

BOTTOM VIEW

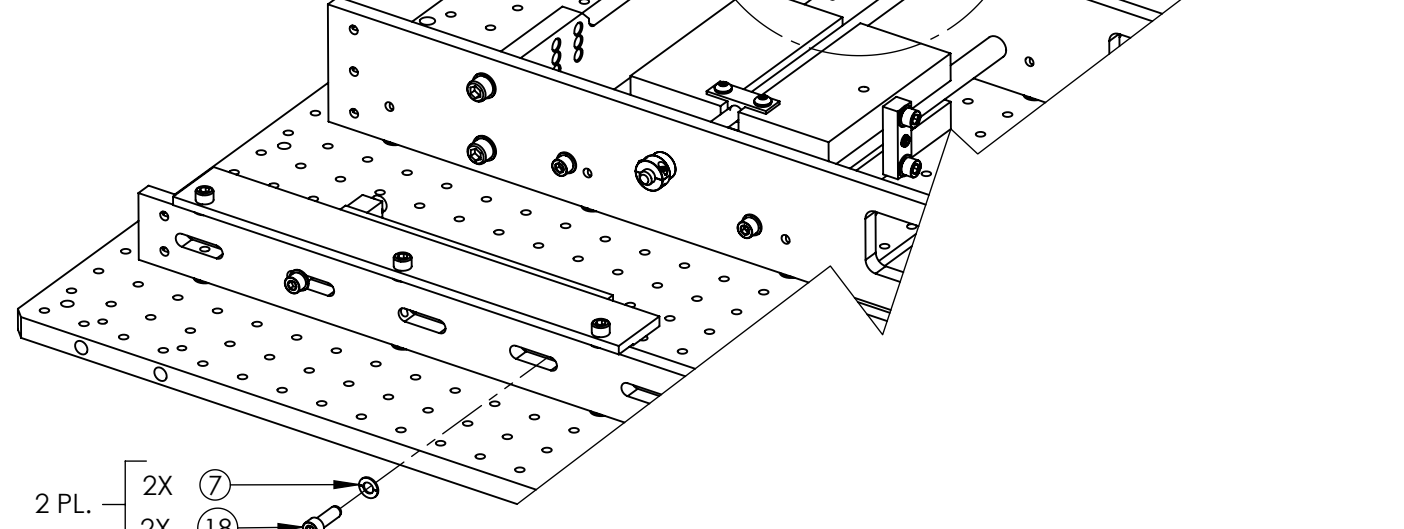

ASSY. STEP 4
(PARTIAL VIEW SHOWN)

D1102291 aLIGO TMS ISC Table Structural Assembly, PART PDM REV: X-063, DRAWING PDM REV: X-020

LIGO CALIFORNIA INSTITUTE OF TECHNOLOGY
MASSACHUSETTS INSTITUTE OF TECHNOLOGY

SIZE	DWG. NO.	REV.
B	D1102291	v9
SCALE: 1:4	PROJECTION:	SHEET 6 OF 9

8 7 6 5 4 3 2 1

D1102291 aLIGO TMS ISC Table Structural Assembly, PART PDM REV: X-063, DRAWING PDM REV: X-020

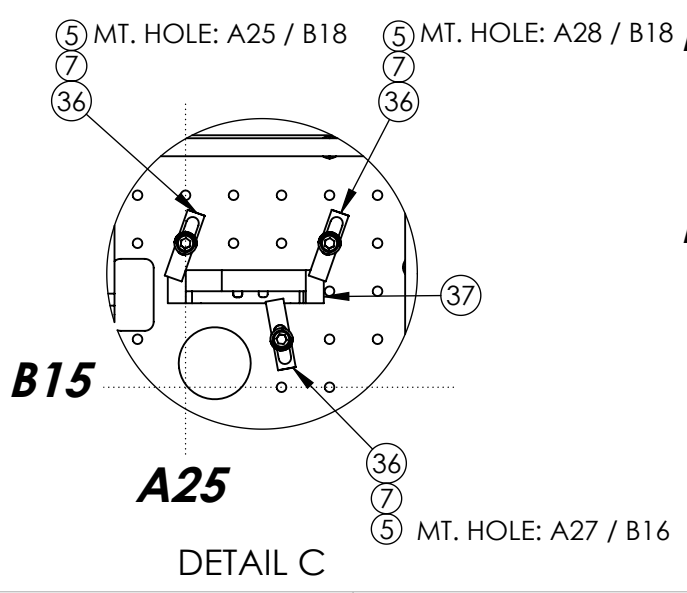
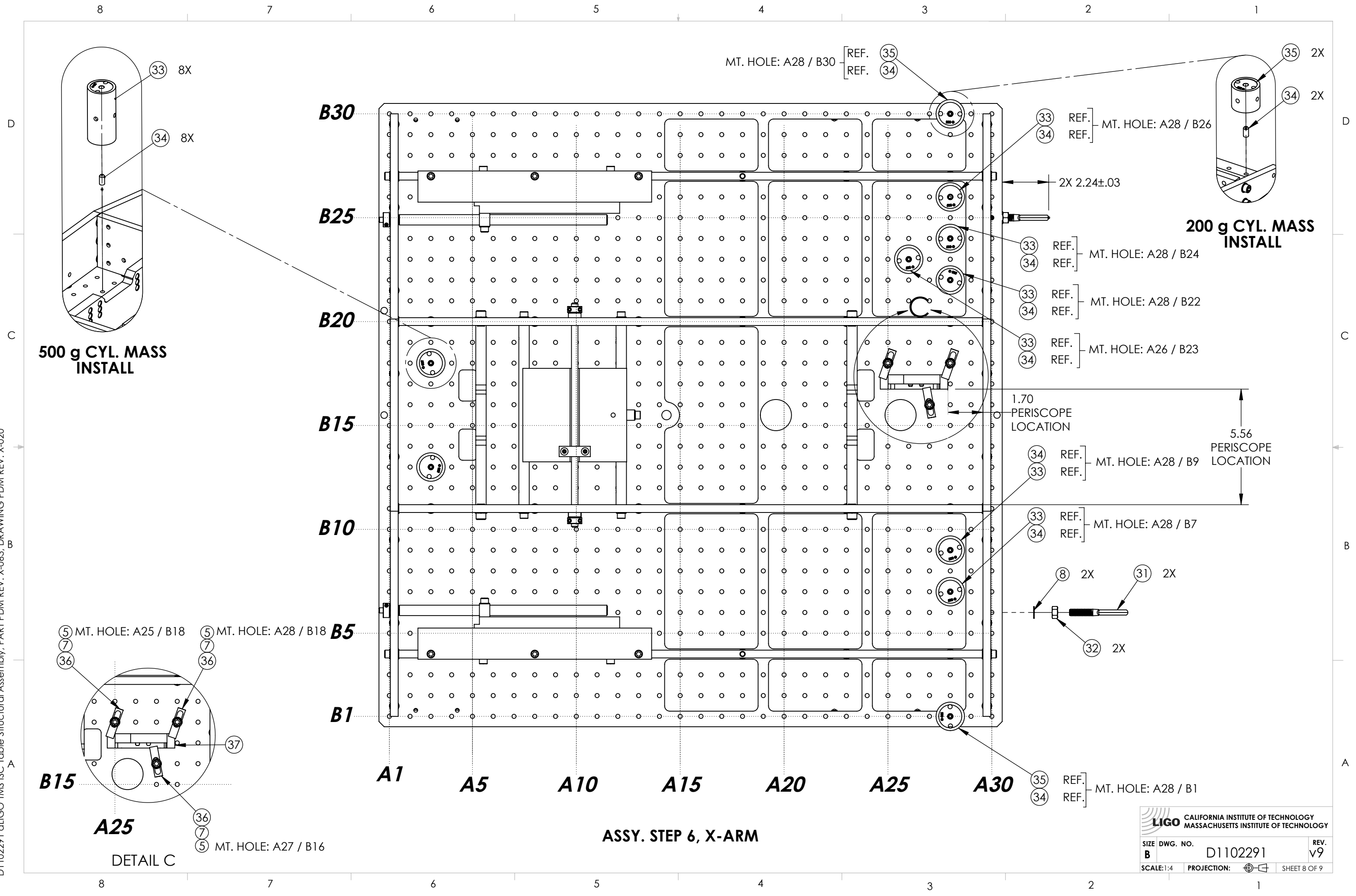

ASSY. STEP 6, X-ARM

LIGO CALIFORNIA INSTITUTE OF TECHNOLOGY
MASSACHUSETTS INSTITUTE OF TECHNOLOGY

SIZE	DWG. NO.	REV.
B	D1102291	v9
SCALE: 1:4	PROJECTION:	SHEET 8 OF 9

D1102291 aLIGO TMS ISC Table Structural Assembly, PART PDM REV: X-063, DRAWING PDM REV: X-020

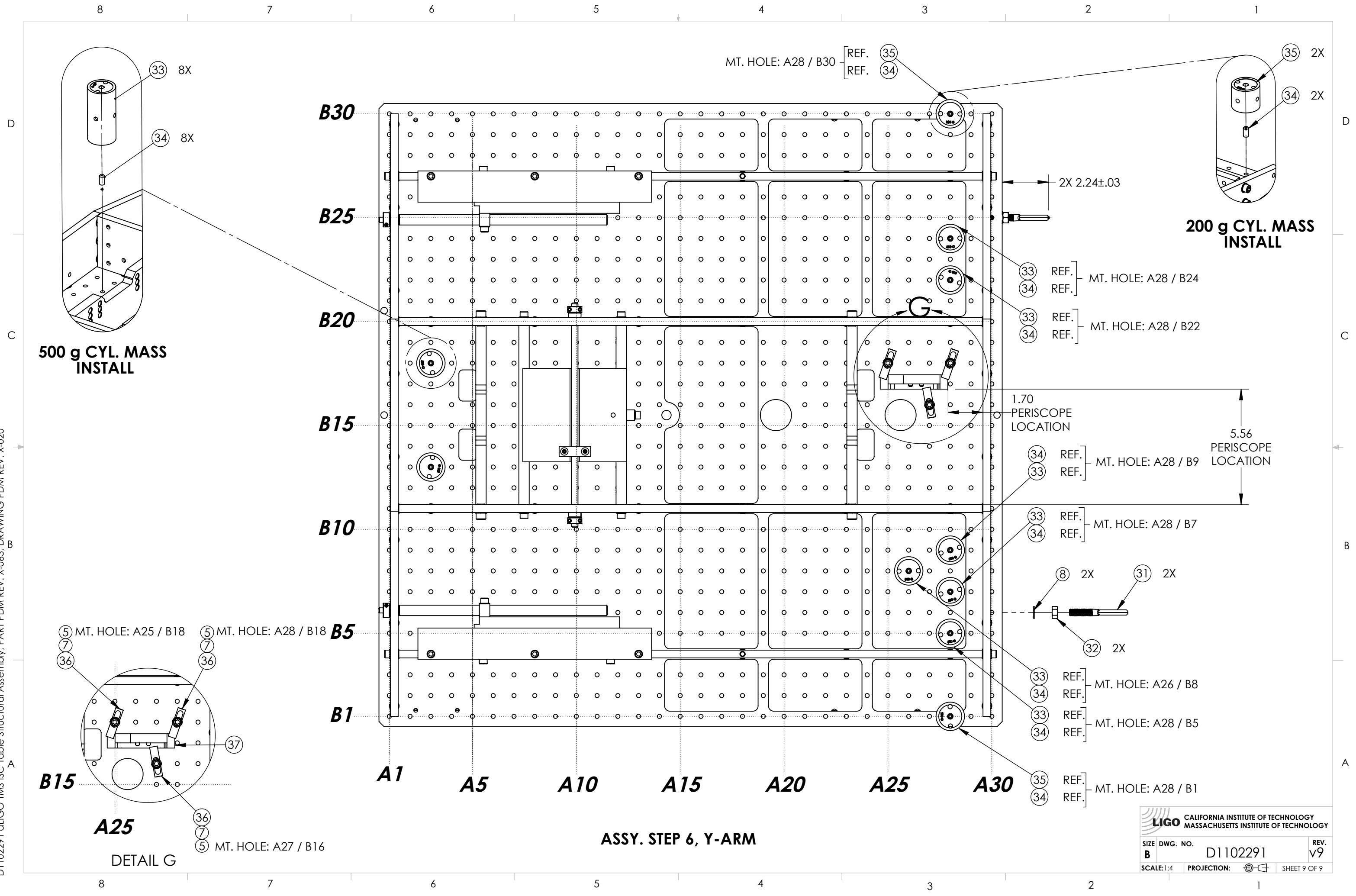

ASSY. STEP 6, Y-ARM

LIGO CALIFORNIA INSTITUTE OF TECHNOLOGY
MASSACHUSETTS INSTITUTE OF TECHNOLOGY

SIZE	DWG. NO.	REV.
B	D1102291	v9
SCALE: 1:4	PROJECTION:	SHEET 9 OF 9