

- SEE LIGO D1002741 FOR ETM AND TMON WIRING DIAGRAM.
- SEE LIGO D1003312 FOR RING HEATER WIRING DIAGRAM.
- SEE LIGO D1101462 FOR ISC/TRANSMON WIRING DIAGRAM.

④ THE LENGTH OF CABLE(S) BETWEEN CLAMPS (CABLE TIES) SHOULD BE SUFFICIENT TO FORM A LOOSE 'S' SHAPE, BUT WITHOUT CONTACTING ANY PART WHEN ROUTING FROM ANY ISOLATED STAGE (i.e.: OPTICS TABLE TO STAGE 2, STAGE 2 TO STAGE 1, STAGE 1 TO STAGE 0)

CABLE BRACKET DES.	LIGO PART NO.
CB-1	D1001347-1
CB-2	D1001347-1
CB-3	D1001347-2
CB-4	D1001347-2
CB-5	D1001347-2
CB-6	D1101305-1

REV.	DATE	DCN #	DRAWING TREE #
v1	06 MAY 2013	-	-
v2	10 OCT 2013	-	-
-	-	-	-

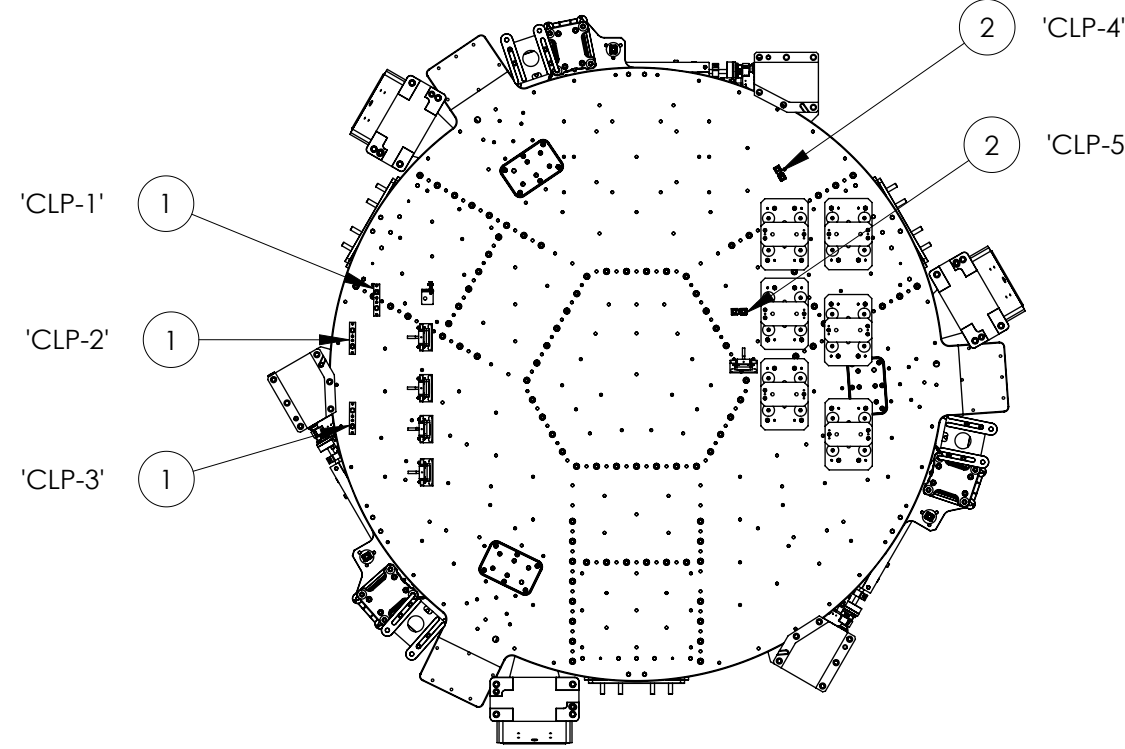
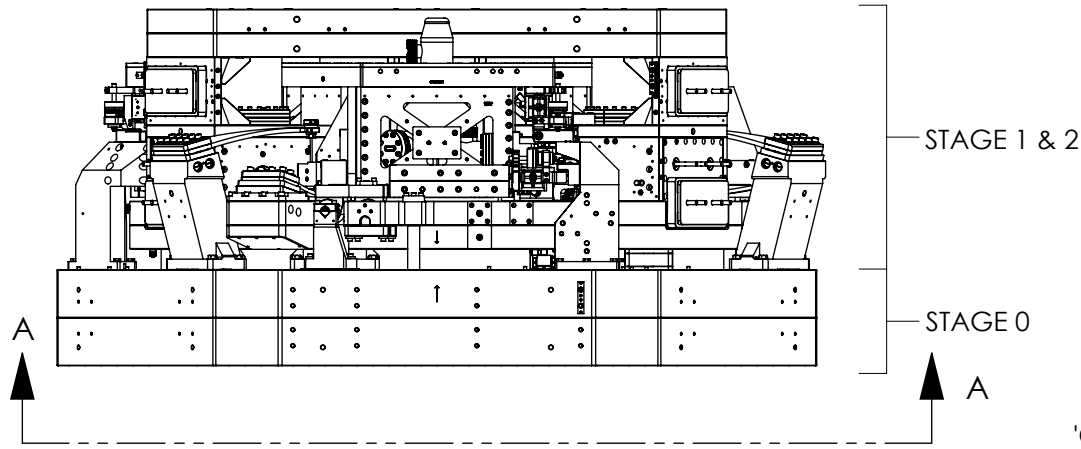

SECTION A-A
CLAMP IDENTIFICATION
(STAGE 0 MONOLITHIC TOP & BOTTOM, NOT SHOWN FOR CLARITY)

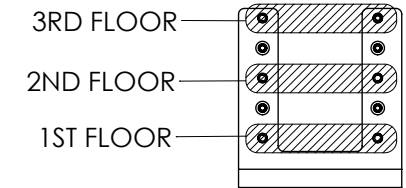

D1001347-2
(3 PORTS)

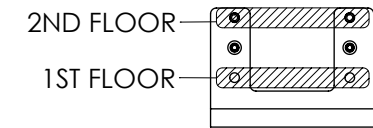

D1001347-1
(2 PORTS)

CABLE BRACKETS
TYP.

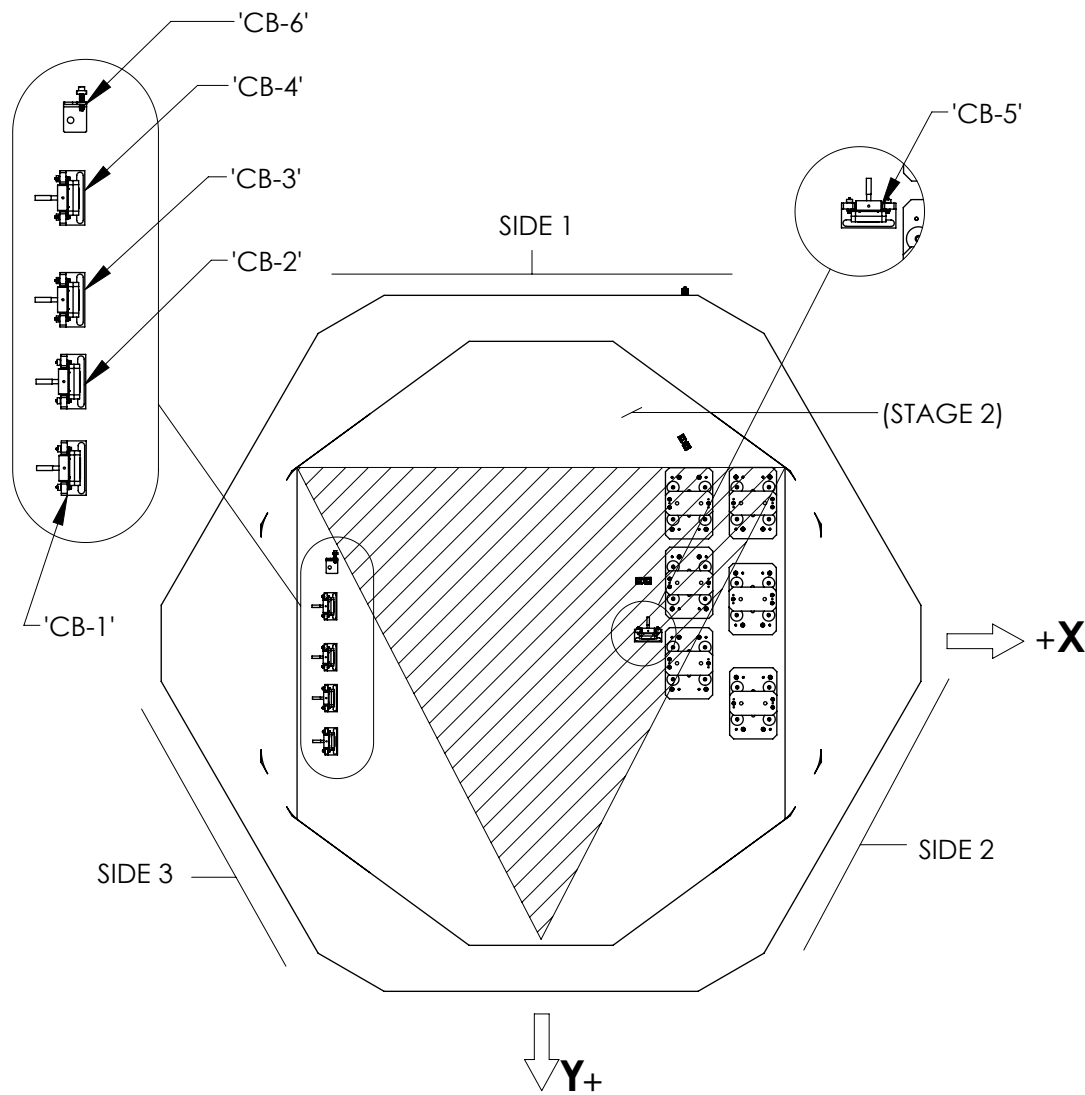

CABLE BRACKET IDENTIFICATION/ORIENTATION
AS VIEWED FROM BELOW (LOOKING UP)
(THE BASE OF THE TRIANGLE SPANS THE SUPPORT TUBES;
THE REST OF THE TRIANGLE FOLLOWS THE SHAPE OF THE KEEL PLATE)
SEE LIGO G1000125 FOR REFERENCE

ITEM NO.	PART NUMBER	DESCRIPTION	QTY.
5	D1001347-1	αLIGO, ASSY, CABLE BRACKET, BSC TABLE (2 PORT)	3
4	D1001347-2	αLIGO, ASSY, CABLE BRACKET, BSC TABLE (3 PORT)	2
3	D1101305-1	αLIGO, SUS, UHV CONNECTOR CLAMP ASSY. (TABLE MT.)	1
2	-	UHV COMPATIBLE CABLE CLAMP ASSY, .375-16	6
1	D0902670	CABLE TIE, ALIGO BSC ISI	10

NOTES AND TOLERANCES: (UNLESS OTHERWISE SPECIFIED)

MATERIAL	N/A	FINISH	N/A μinch
----------	-----	--------	-----------

LIGO CALIFORNIA INSTITUTE OF TECHNOLOGY
MASSACHUSETTS INSTITUTE OF TECHNOLOGY

SYSTEM: ADVANCED LIGO SUB-SYSTEM: SUS
NEXT ASSY: D0900506, D0901154

PARTS LIST			
PART NAME			
αLIGO, CABLE HARNESS ROUTING, BSC5 L1 / BSC10 H1			
DESIGNER	E.SANCHEZ	02 MAY 2013	SIZE DWG. NO.
DRAFTER	E.SANCHEZ	08 MAY 2013	B
CHECKER	SEE DCC	SEE DCC	D1200111
APPROVAL	SEE DCC	SEE DCC	REV. v2
SCALE: 1:24		PROJECTION:	SHEET 1 OF 10

D1200111 - Cable Harness Routing Configuration - BSC-5_BSC10, PART PDM REV: X-004, DRAWING PDM REV: X-001

*SEE D1101775, FOR FLANGE/SUBFLANGE PORT DESIGNATION.

ROUTE NO. 1

D
C
B
A

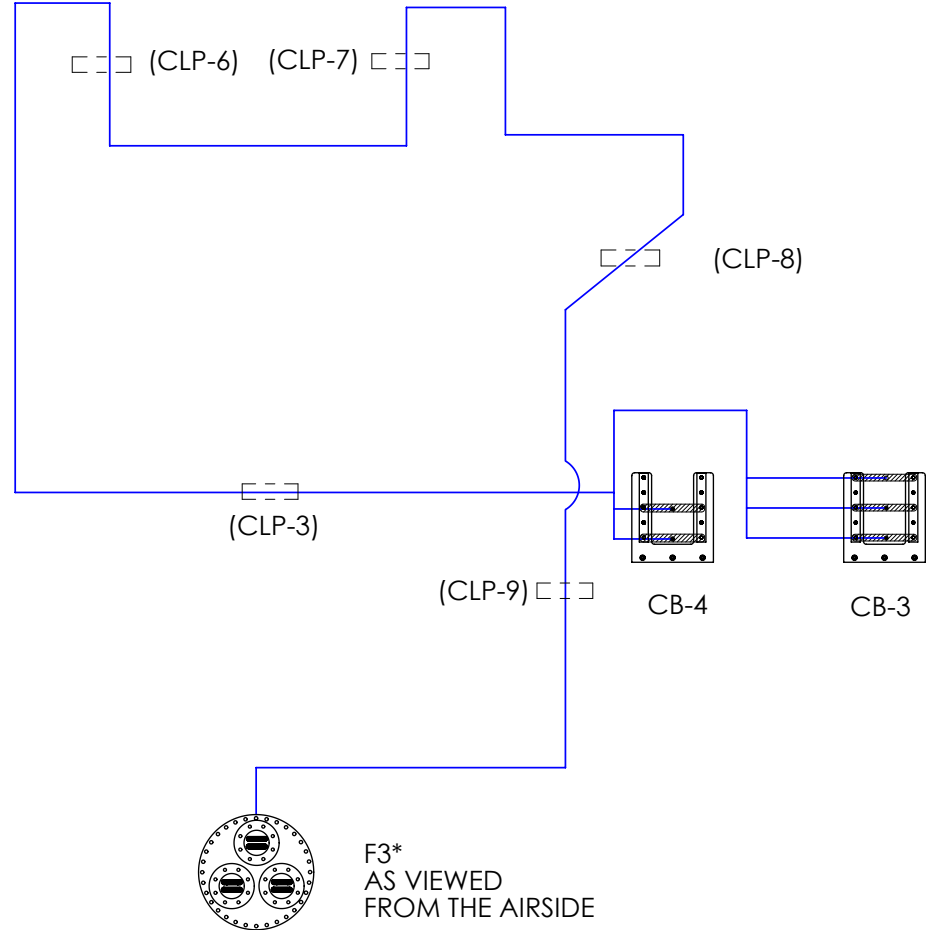
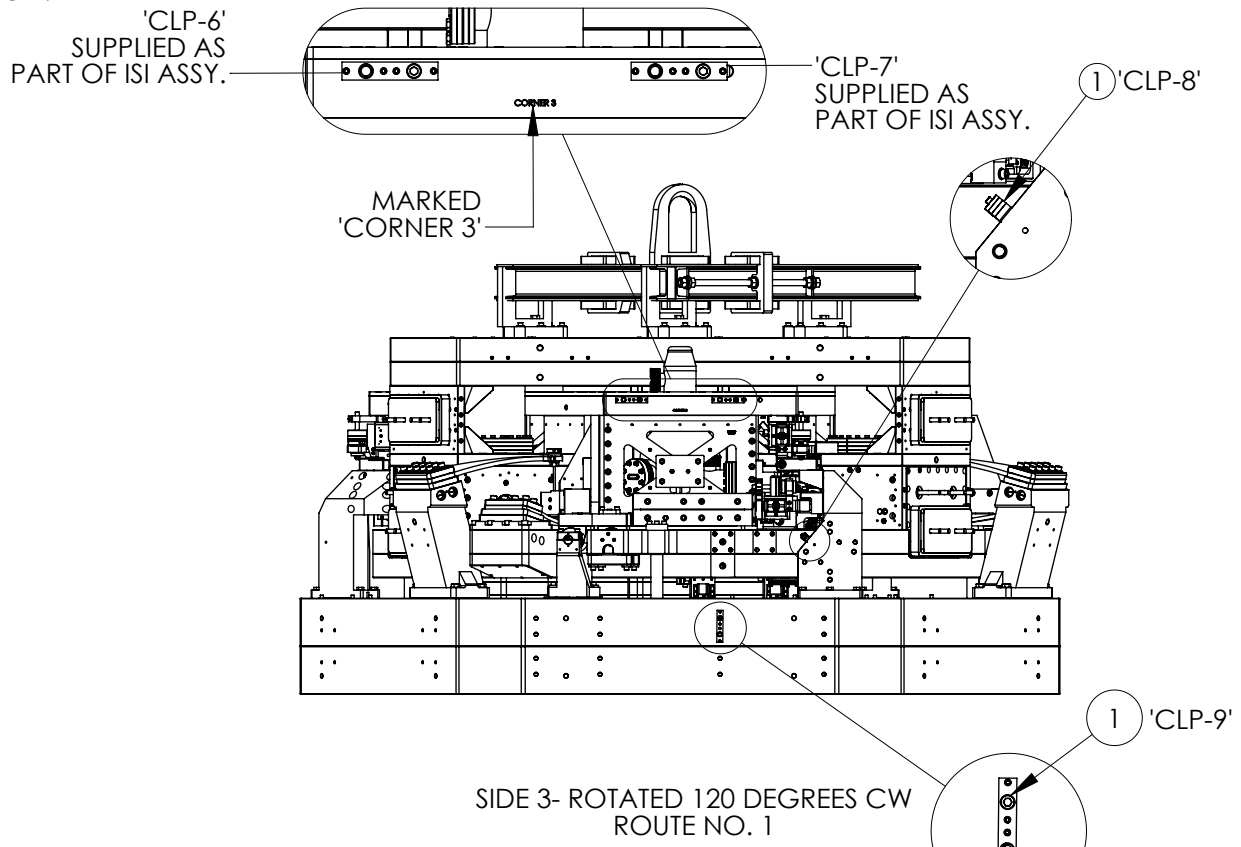

④ ROUTE NO. 1-SEE TABLE 1 FOR CABLING SPECS.
 (ROUTE CABLE/CABLES THROUGH REFERENCED CABLE CLAMPS)
 CABLE QTY. 5

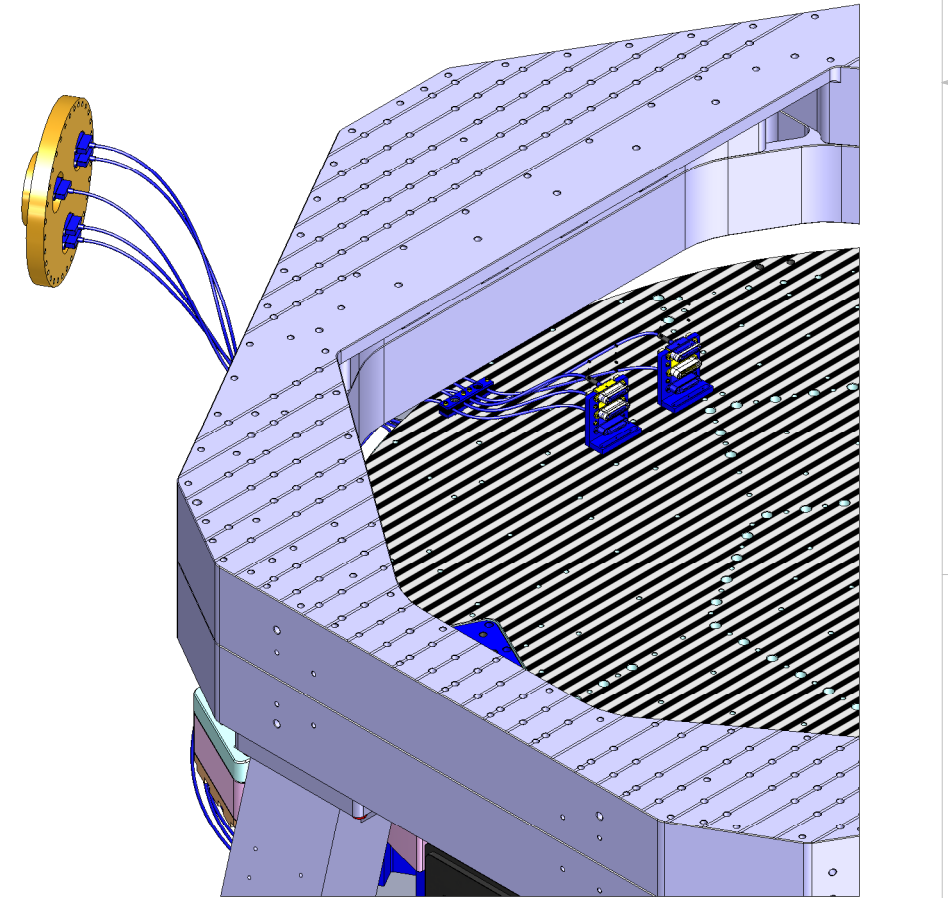
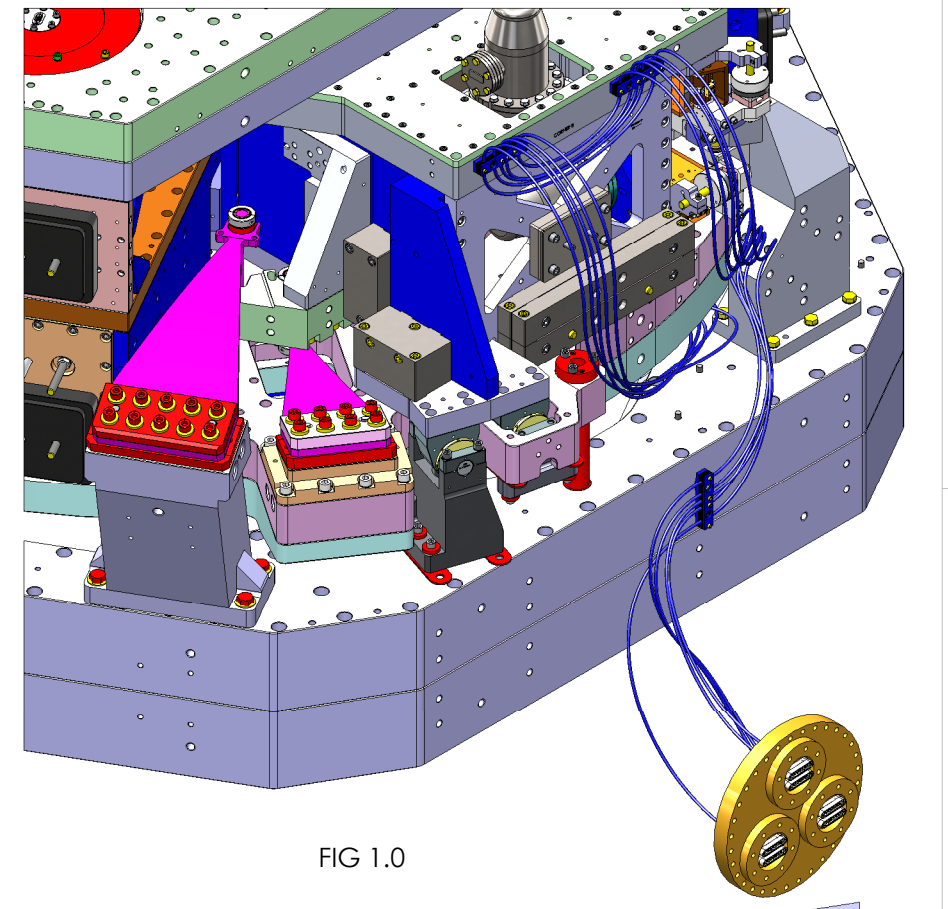
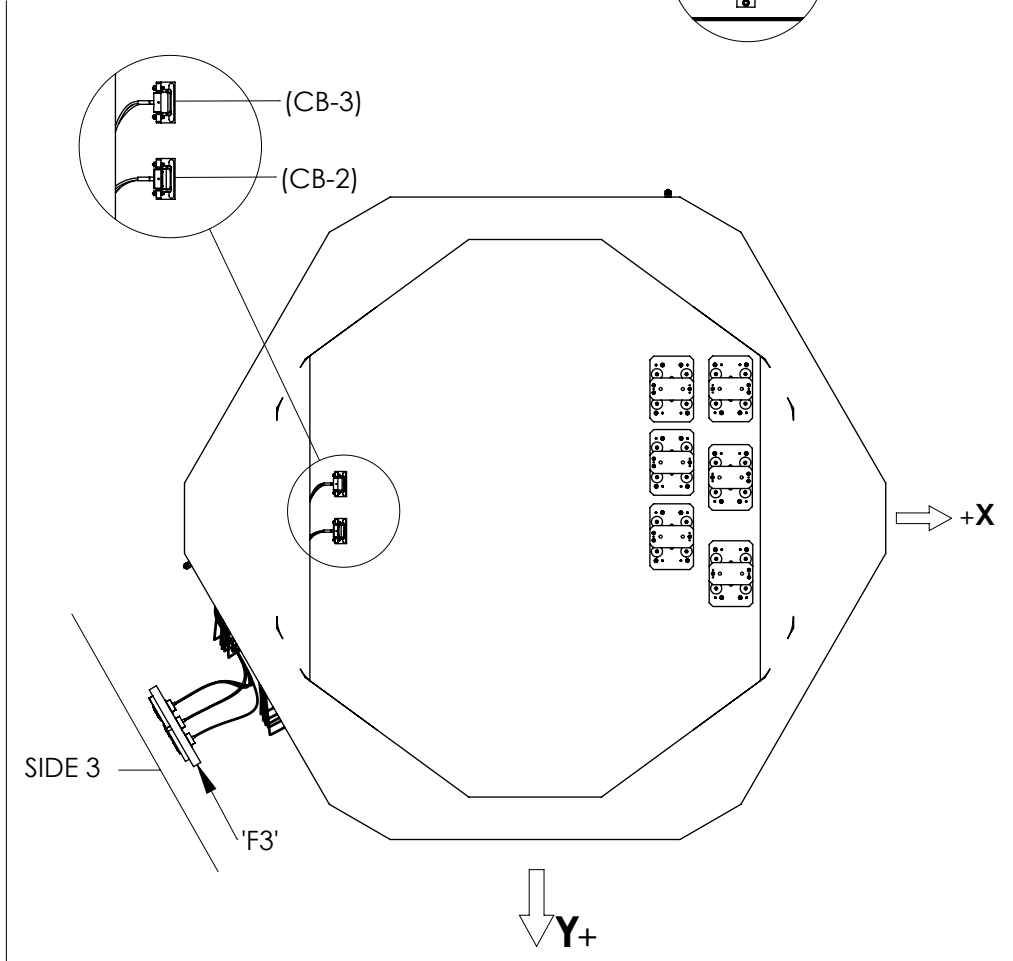

LIGO CALIFORNIA INSTITUTE OF TECHNOLOGY
 MASSACHUSETTS INSTITUTE OF TECHNOLOGY

SIZE DWG. NO. **B** D1200111 REV. **v2**

SCALE: 1:24 PROJECTION: SHEET 2 OF 10

8 7 6 5 4 3 2 1

D1200111 - Cable Harness Routing Configuration - BSC-5_BSC10, PART PDM REV: X-004, DRAWING PDM REV: X-001

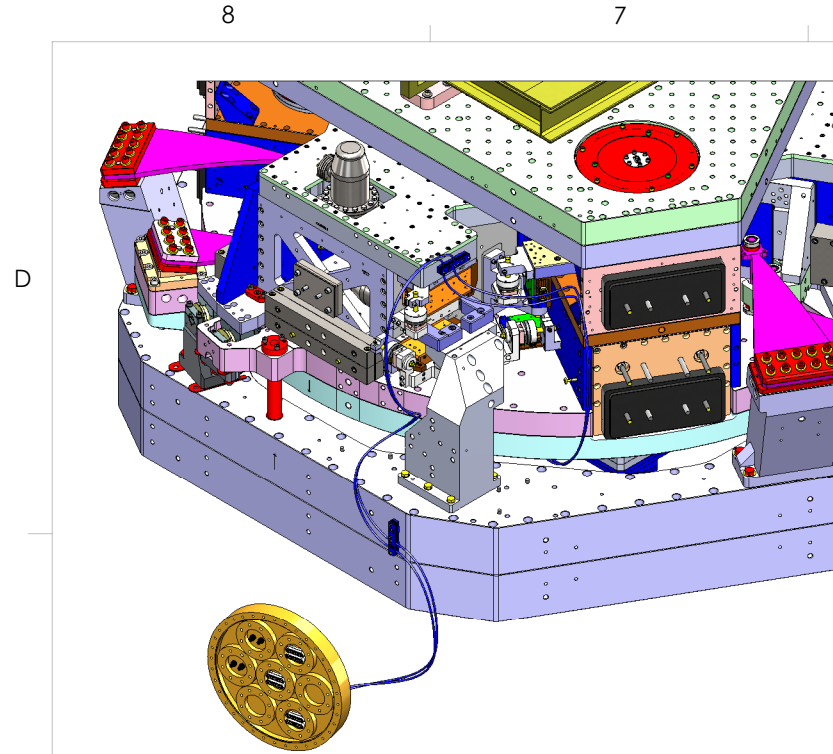
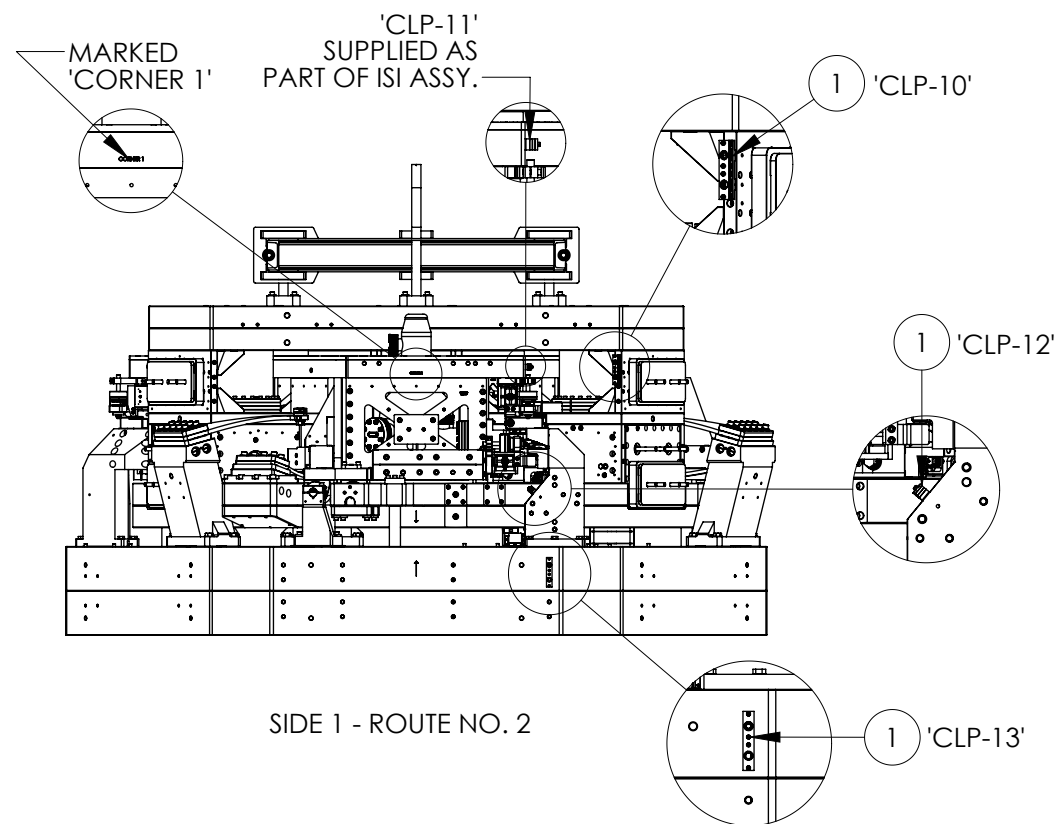

FIG 2.0



SIDE 1 - ROUTE NO. 2

SIDE 1

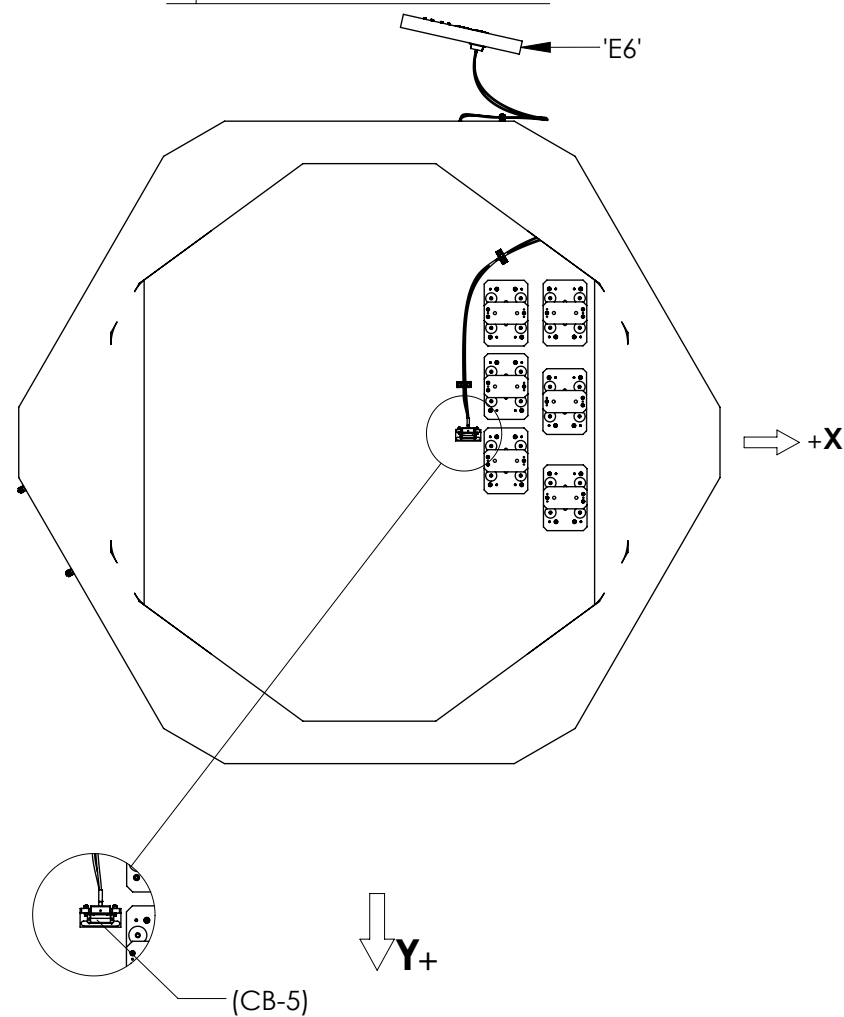
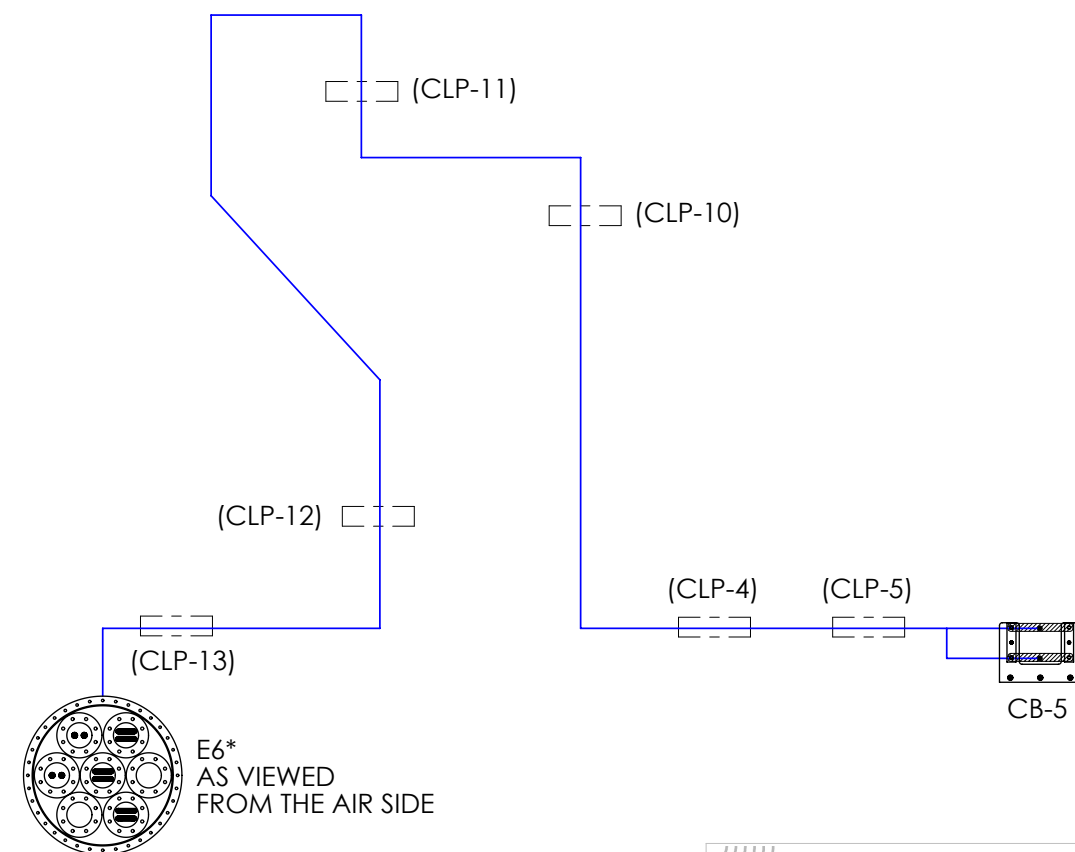

FIG 2.1
UNERSIDE VIEW

④ ROUTE NO. 2-SEE TABLE 1 FOR CABLING SPECS.
(ROUTE CABLE/CABLES THROUGH REFERENCED CABLE CLAMPS)
CABLE QTY. 2



ROUTE NO. 2

*SEE D1101775, FOR FLANGE/SUBFLANGE PORT DESIGNATION.

D1200111 - Cable Harness Routing Configuration - BSC-5_BSC10, PART PDM REV: X-004, DRAWING PDM REV: X-001

*SEE D1101775, FOR FLANGE/SUBFLANGE PORT DESIGNATION.

ROUTE NO. 3

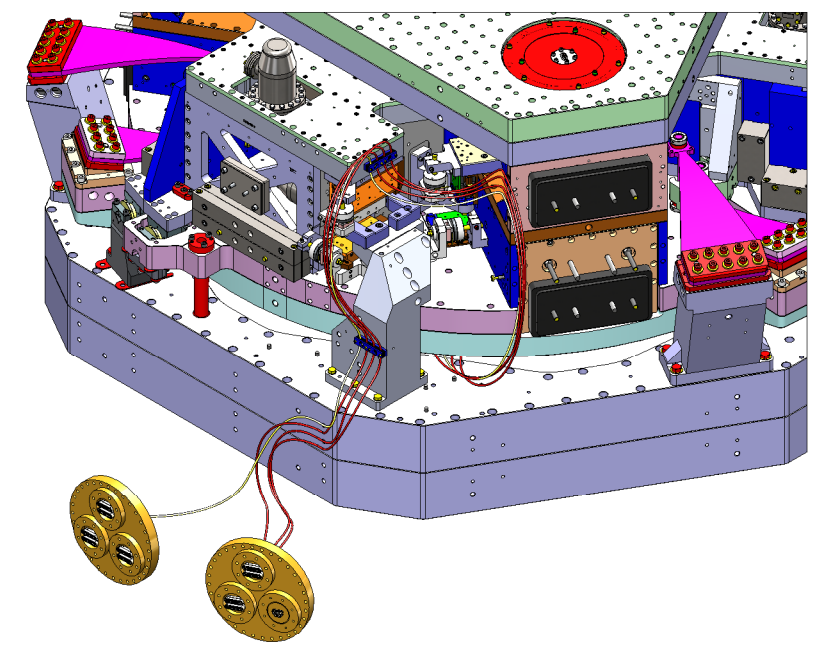
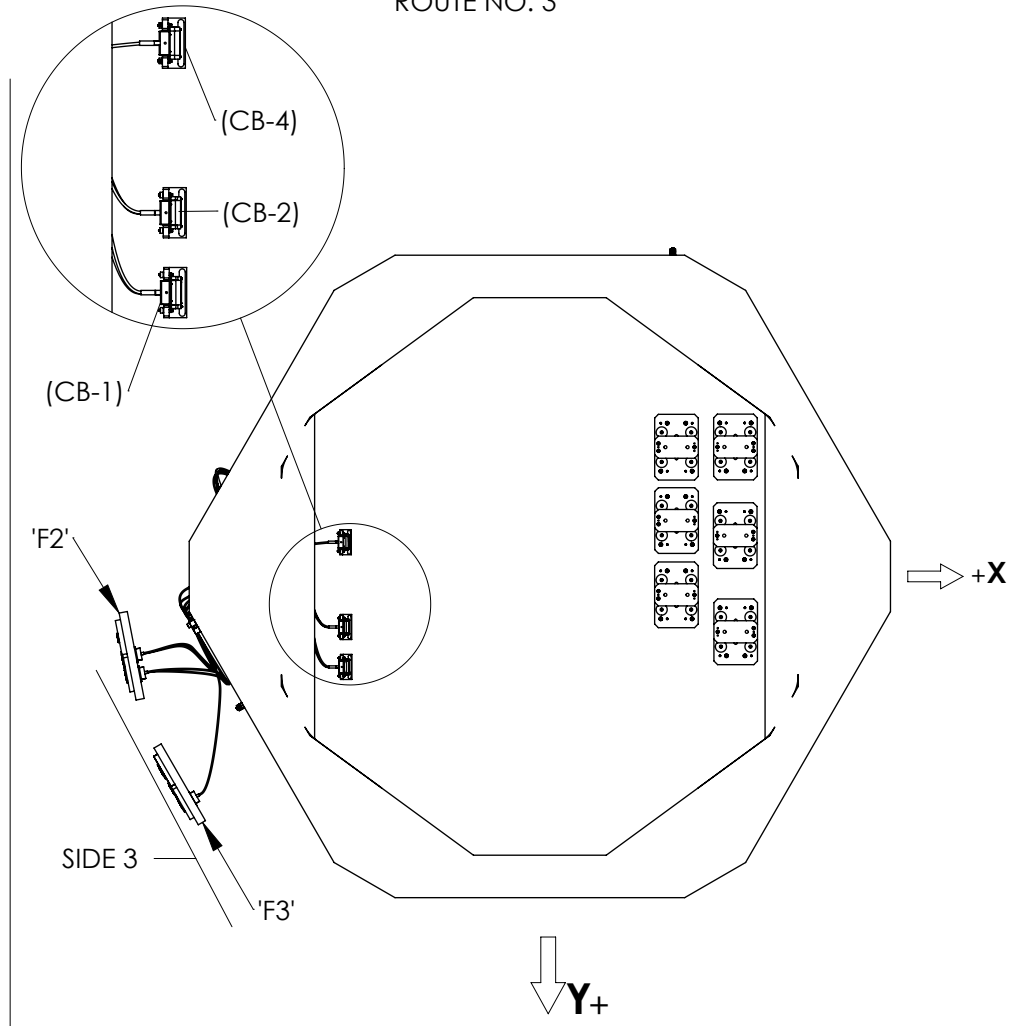
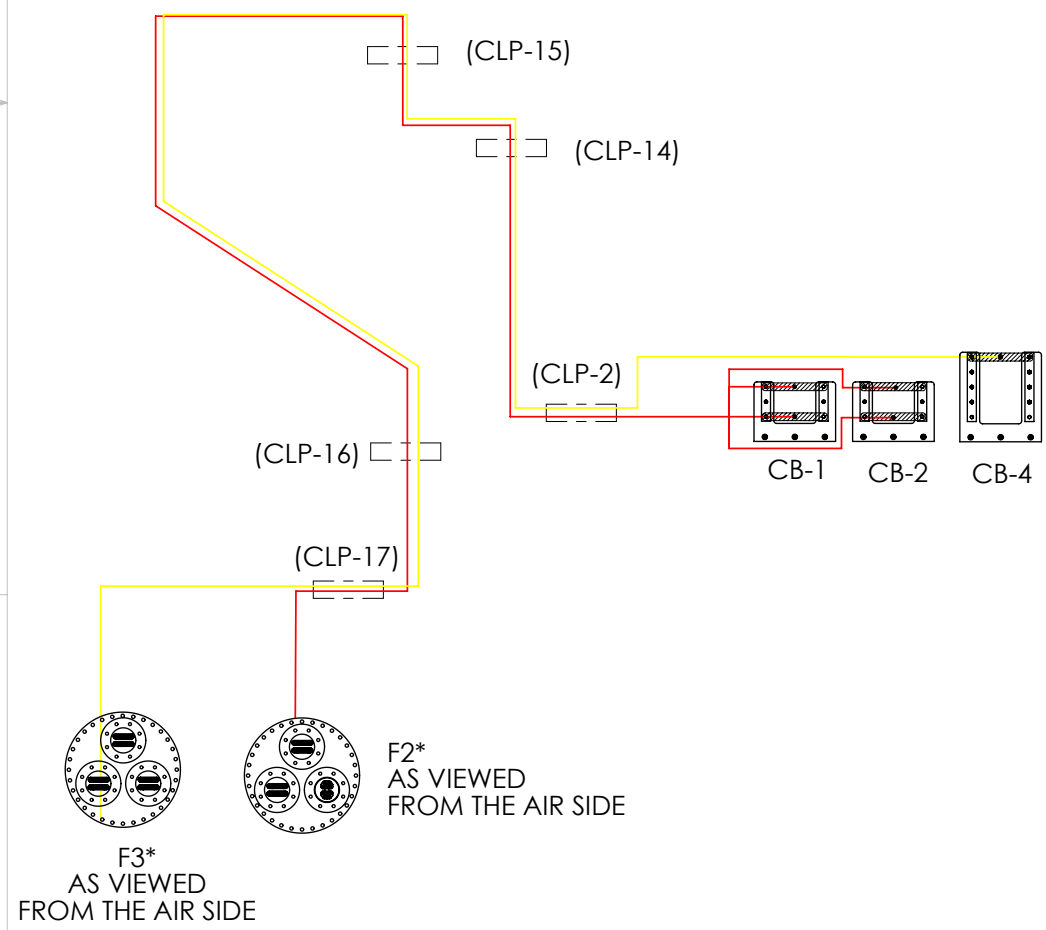
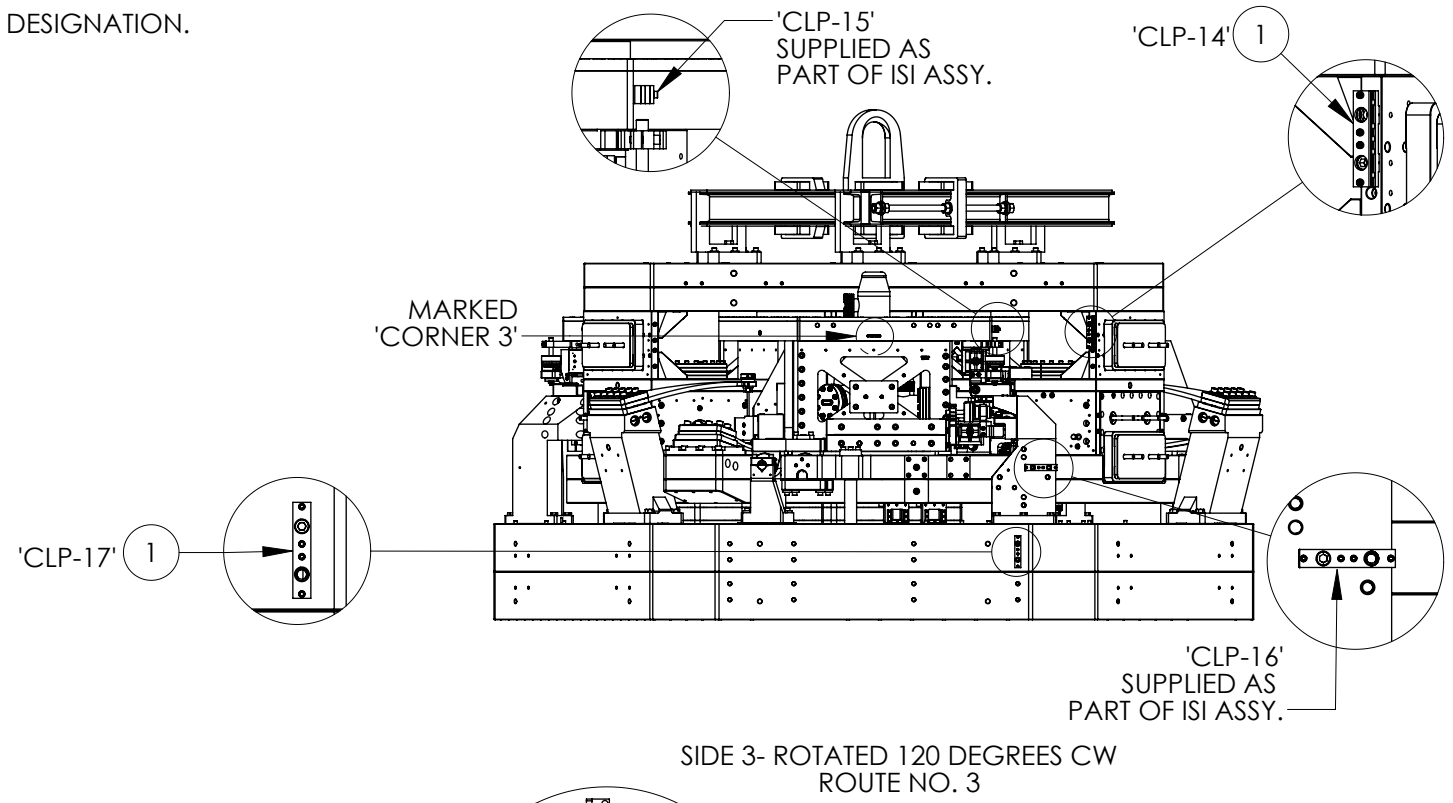

FIG 3.0

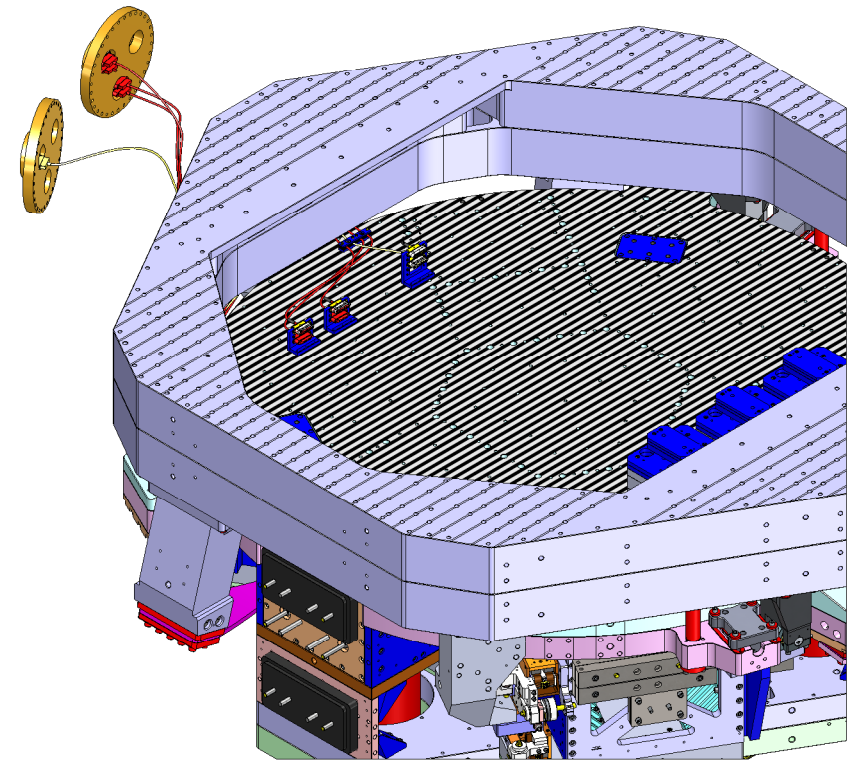

FIG 3.1
UNDERSIDE VIEW

④ ROUTE NO. 3-SEE TABLE 1 FOR CABLING SPECS.
(ROUTE CABLE/CABLES THROUGH REFERENCED CABLE CLAMPS)
CABLE QTY. 5

D1200111 - Cable Harness Routing Configuration - BSC5_BSC10, PART PDM REV: X-004, DRAWING PDM REV: X-001

*SEE D1101775, FOR FLANGE/SUBFLANGE PORT DESIGNATION.

ROUTE NO. 4

D
C
B
A

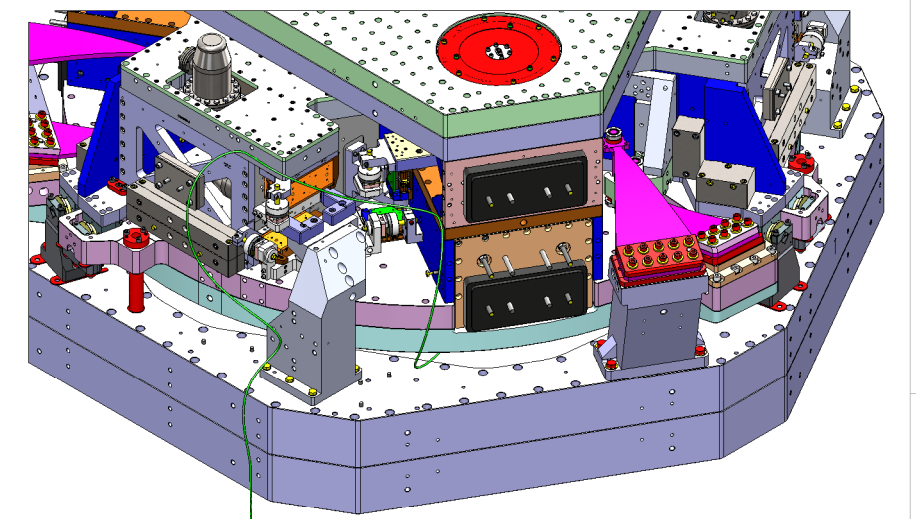
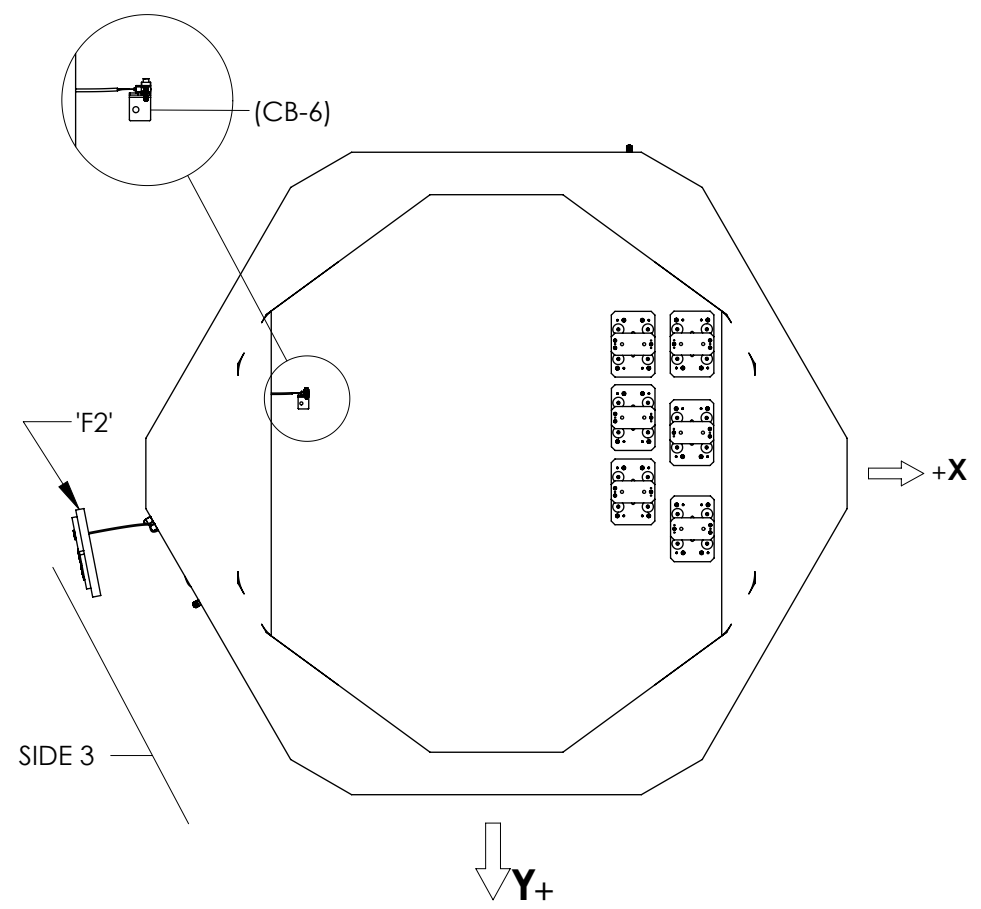
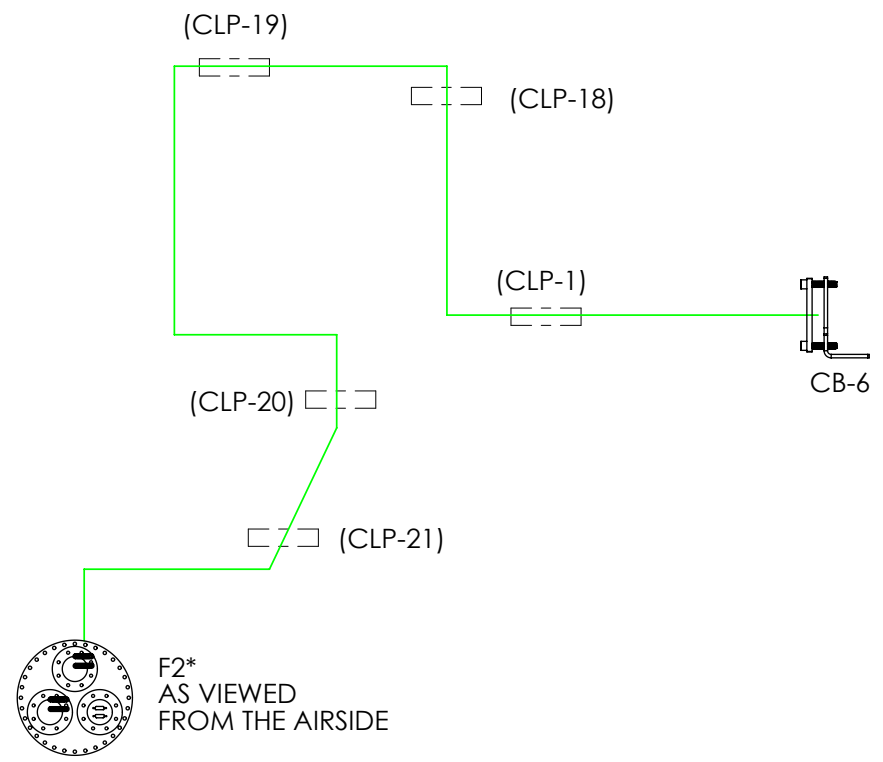
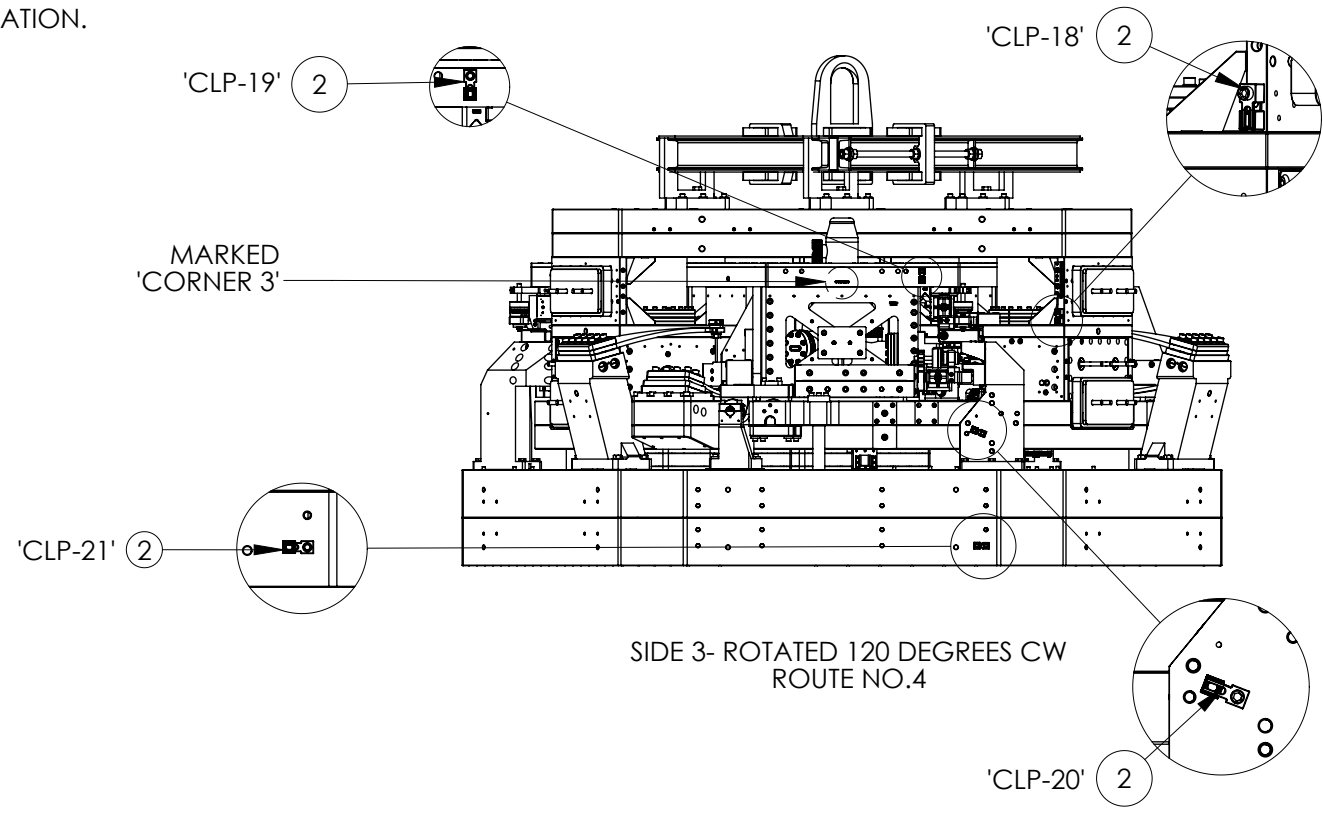

FIG 4.0

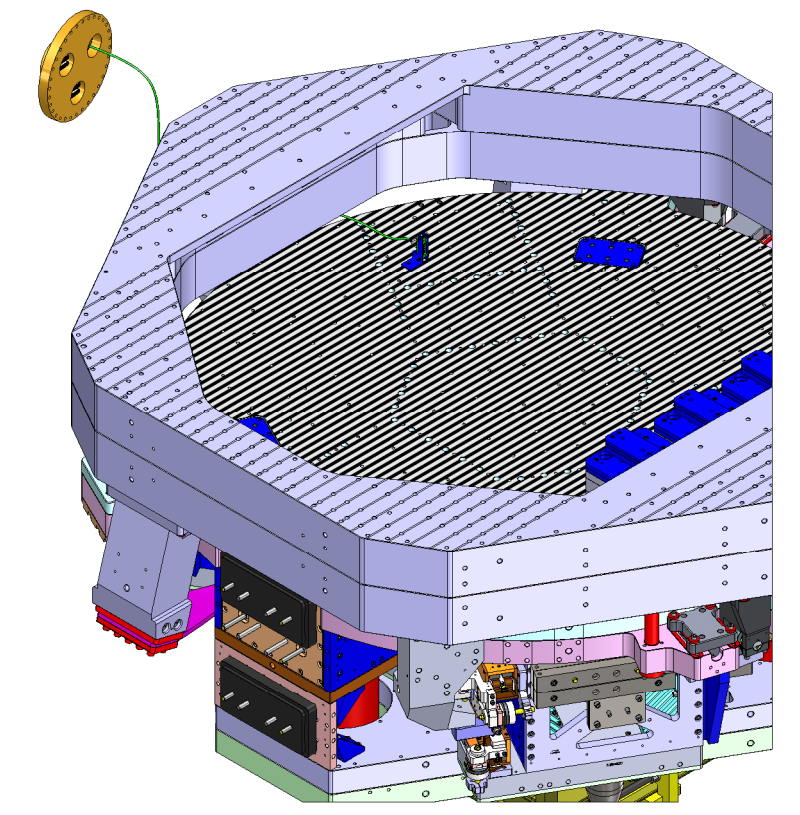

FIG 4.1
UNDERSIDE VIEW

④ ROUTE NO. 4-SEE TABLE 1 FOR CABLING SPECS.
(ROUTE CABLE/CABLES THROUGH REFERENCED CABLE CLAMPS)
CABLE QTY. 1

LIGO CALIFORNIA INSTITUTE OF TECHNOLOGY
MASSACHUSETTS INSTITUTE OF TECHNOLOGY

SIZE	DWG. NO.	REV.
B	D1200111	v2
SCALE: 1:24	PROJECTION:	SHEET 5 OF 10

8 7 6 5 4 3 2 1

D1200111 - Cable Harness Routing Configuration - BSC-5_BSC10, PART PDM REV: X-004, DRAWING PDM REV: X-001

TABLE 1- BSC 5 / BSC 10 CABLING SPECIFICATIONS: ROUTES, BRACKETS DES., SUBSYSTEM AND CABLE DESCRIPTIONS.

CABLE NO.	CABLE ROUTE	TOTAL CABLE QTY.	CABLE LENGTH (IN)	CABLE NO.	FROM FLANGE DES./PORT	TO ASSIGNED CABLE BRACKET REF.DES.	CABLE BRACKET FLOOR	TABLE CABLING SPECS.								TO SUSPENSION REF. DES.	DESCRIPTION	SUBSYSTEM
								CABLE NO.	CABLE LENGTH (IN)	FROM	TO	CABLE LENGTH (IN)	TO	CABLE LENGTH (IN)	TO			
1	ROUTE NO. 1	5	180	D1000225	F3-1C1	CB-3	1ST	D1000234	88	CB-3 (1ST)	-	-	-	-	M0	ETMY	SUS - QUAD 1	SUS
2					F3-1C2		2ND	D1000234	88	CB-3 (2ND)	-	-	-	-	M0, R0		SUS - QUAD 1	
3					F3-2C1		3RD	D1000234	88	CB-3 (3RD)	-	-	-	-	R0		SUS - QUAD 1	
4					F3-2C2	CB-4	1ST	D1002522	121	CB-4 (1ST)	-	-	D1002523	12	UIM		SUS - QUAD 1	
5					F3-3C1		2ND	D1002522	156	CB-4 (2ND)	-	-	D1002524	17	PUM		SUS - QUAD 1	
6	ROUTE NO. 2	2	199	D1000234	E6-7C1	CB-5	1ST	D1000234	88	CB-5 (1ST)	-	-	-	-	TMONY	TRANSMON	4 BOSEMS ON TOP STAGE	SUS /AOS
7					E6-7C2		2ND	D1000234	60	CB-5 (2ND)	-	-	-	-	TMONY		2 BOSEMS ON TOP STAGE	
8	ROUTE NO. 3	1	180	D1000223	F3-3C2	CB-4	3RD	D1001521	114	CB-4 (3RD)	D1001520	120	D1001519	28	LOWER RING HEATER	TCS	TCS - RING HEATER	TCS
9		1	216		F2-1C1		1ST	D1000921	143	CB-1 (1ST)	D1000238	36	-	-	-	ISC PM		
10		1	216		F2-2C2		2ND	D1000921	143	CB-1 (2ND)	D1000237	36	-	-	-	BEAM DIVERTER	ETM TRANSMON	ISC - TRANSMON BEAM DIVERTER
11		1	216		F2-2C1		1ST	D1000924	143	CB-2 (1ST)	D1000231	36	-	-	-	ISC QPD	QPD	ISC - ETM TRANSMON 532 nm
12	1	216	F2-1C2	2ND	D1000924	143	CB-2 (2ND)	D1000231	36	-	-	-	ETM TRANSMON	ISC - ETM TRANSMON 1064 nm				
13	ROUTE NO 4	1	199	D1101617	F2-3SRI	CB-6	N/A	D1101472	-	CB-6	D1101517	-	-	-	BOTTOM MASS	ETMY	SUS - ESD FOR QUAD 1	SUS

FOR INTERCONNECT CABLING DIAGRAM, SEE SHEETS 7, 8, 9, AND 10

CABLE COUNT (SUPPLIED FOR REF. ONLY)		CABLE COUNT (SUPPLIED FOR REF. ONLY)	
CABLE DCC NO.	QTY. NEEDED	CABLE DCC NO.	QTY. NEEDED
D1000223	2	D1001518	1
D1000225	8	D1001519	1
D1000231	2	D1001520	1
D1000234	5	D1001521	1
D1000237	1	D1002522	2
D1000238	1	D1002523	1
D1000568	2	D1002524	1
D1000921	2	D1101617	1
D1000924	2	D1101517	1
		D1101472	1

SEE E1100730 FOR DETAILED IN-VACUUM CABLE DATA
(i.e.: STATUS AND AVAILABILITY)

CALIFORNIA INSTITUTE OF TECHNOLOGY
MASSACHUSETTS INSTITUTE OF TECHNOLOGY

SIZE	DWG. NO.	REV.
B	D1200111	v2

SCALE: 1:24 PROJECTION:  SHEET 6 OF 10

D1200111 - Cable Harness Routing Configuration - BSC5_BSC10, PART PDM REV: X-004, DRAWING PDM REV: X-001

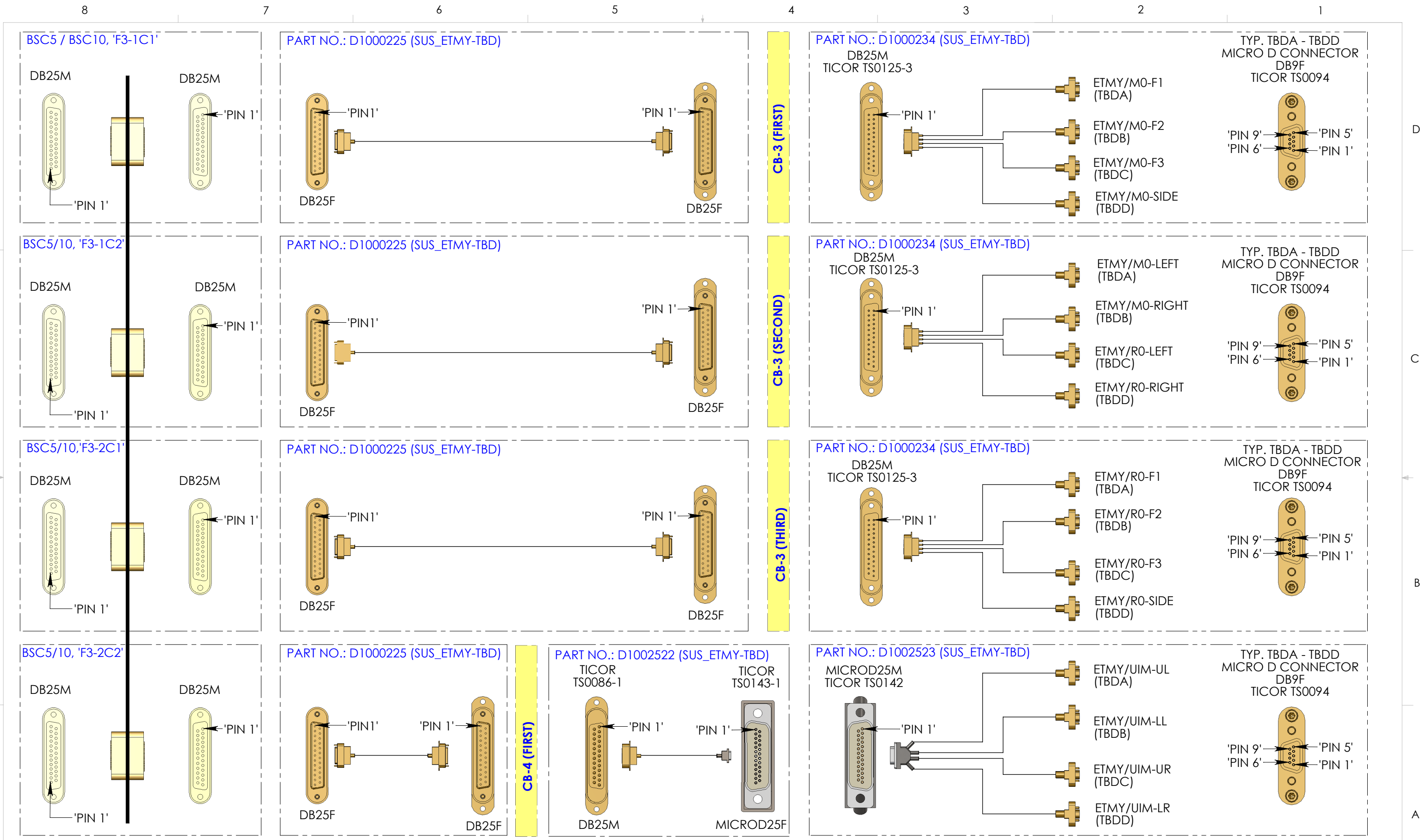

PARENTHESIS DESIGNATIONS REFERENCE WIRING SCHEMATIC, SEE D1002741.

PART NO. & REF. DES. SHOWN ARE FOR REFERENCE ONLY, AND DO NOT APPEAR ON CABLE ASSEMBLIES.

BSC5 / BSC10, INTERCONNECT CABLING DIAGRAM
(CONTINUED ON SHEET 8)

CALIFORNIA INSTITUTE OF TECHNOLOGY MASSACHUSETTS INSTITUTE OF TECHNOLOGY		
SIZE	DWG. NO.	REV.
B	D1200111	v2
SCALE: 1:4	PROJECTION:	SHEET 7 OF 10

D1200111 - Cable Harness Routing Configuration - BSC5_BSC10, PART PDM REV: X-004, DRAWING PDM REV: X-001

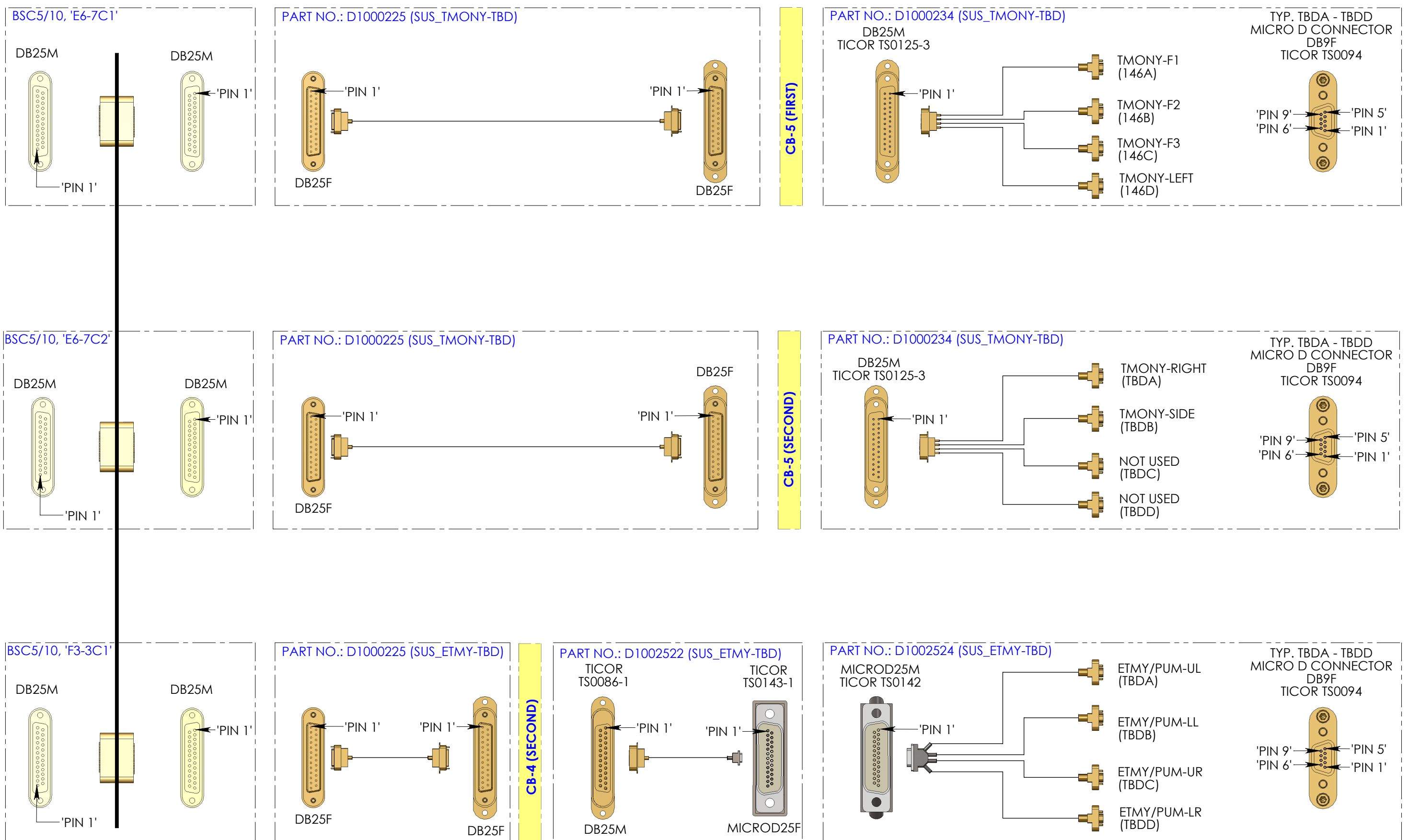

BSC5 / BSC10, INTERCONNECT CABLING DIAGRAM
(CONTINUED ON SHEET 9)

PARENTHESIS DESIGNATIONS REFERENCE WIRING SCHEMATIC, SEE D1002741.
PART NO. & REF. DES. SHOWN ARE FOR REFERENCE ONLY, AND DO NOT APPEAR ON CABLE ASSEMBLIES.

LIGO CALIFORNIA INSTITUTE OF TECHNOLOGY
MASSACHUSETTS INSTITUTE OF TECHNOLOGY

SIZE	DWG. NO.	REV.
B	D1200111	v2
SCALE: 1:4	PROJECTION:	SHEET 8 OF 10

D1200111 - Cable Harness Routing Configuration - BSC5_BSC10, PART PDM REV: X-004, DRAWING PDM REV: X-001

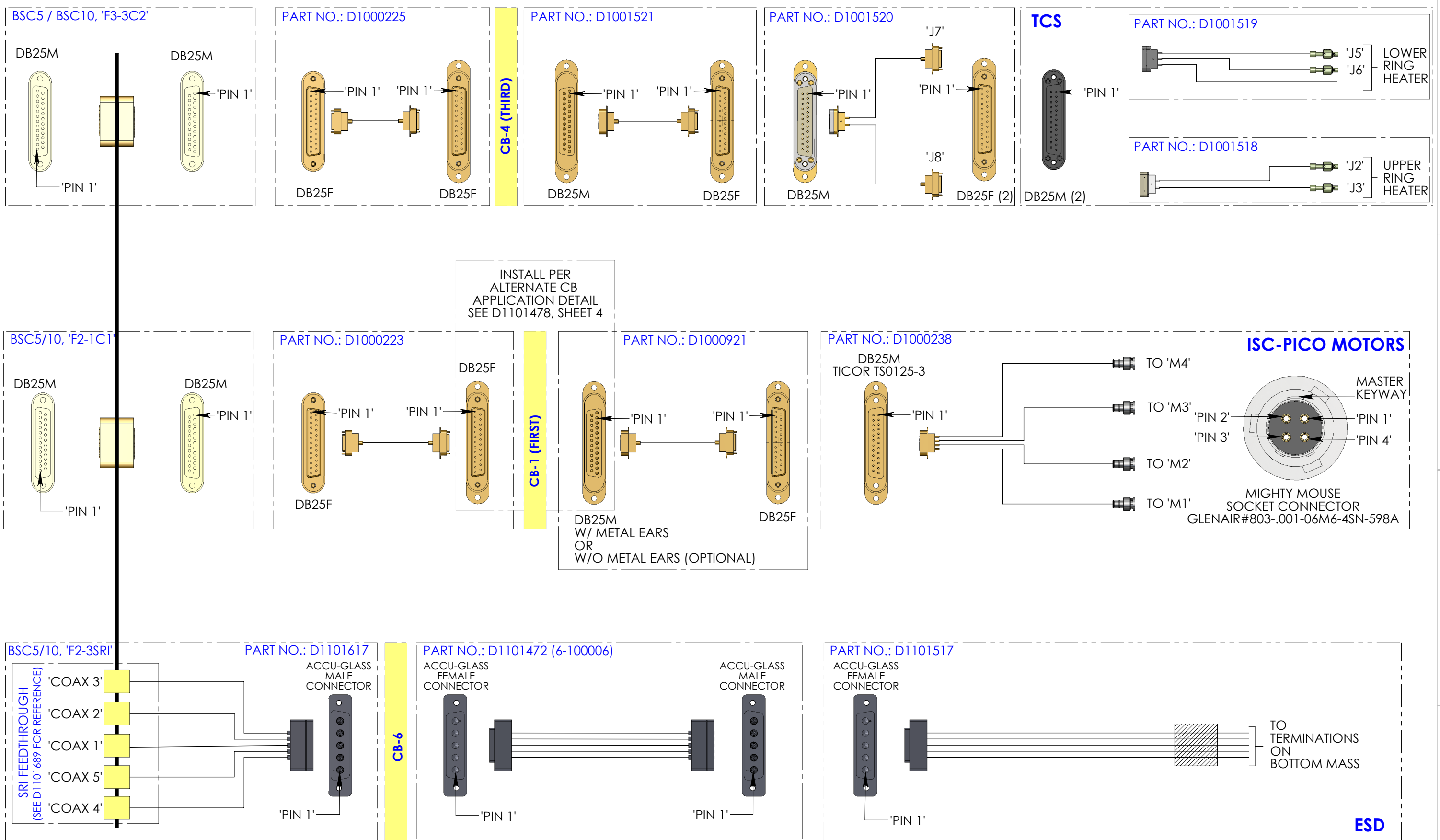

PARENTHESIS DESIGNATIONS REFERENCE WIRING SCHEMATIC, SEE D1002741.
 PART NO. & REF. DES. SHOWN ARE FOR REFERENCE ONLY, AND DO NOT APPEAR ON CABLE ASSEMBLIES.

BSC5 / BSC10, INTERCONNECT CABLING DIAGRAM (CONTINUED ON SHEET 10)

LIGO CALIFORNIA INSTITUTE OF TECHNOLOGY
 MASSACHUSETTS INSTITUTE OF TECHNOLOGY

SIZE	DWG. NO.	REV.
B	D1200111	v2
SCALE: 1:4	PROJECTION:	SHEET 9 OF 10

D1200111 - Cable Harness Routing Configuration - BSC5_BSC10, PART PDM REV: X-004, DRAWING PDM REV: X-001

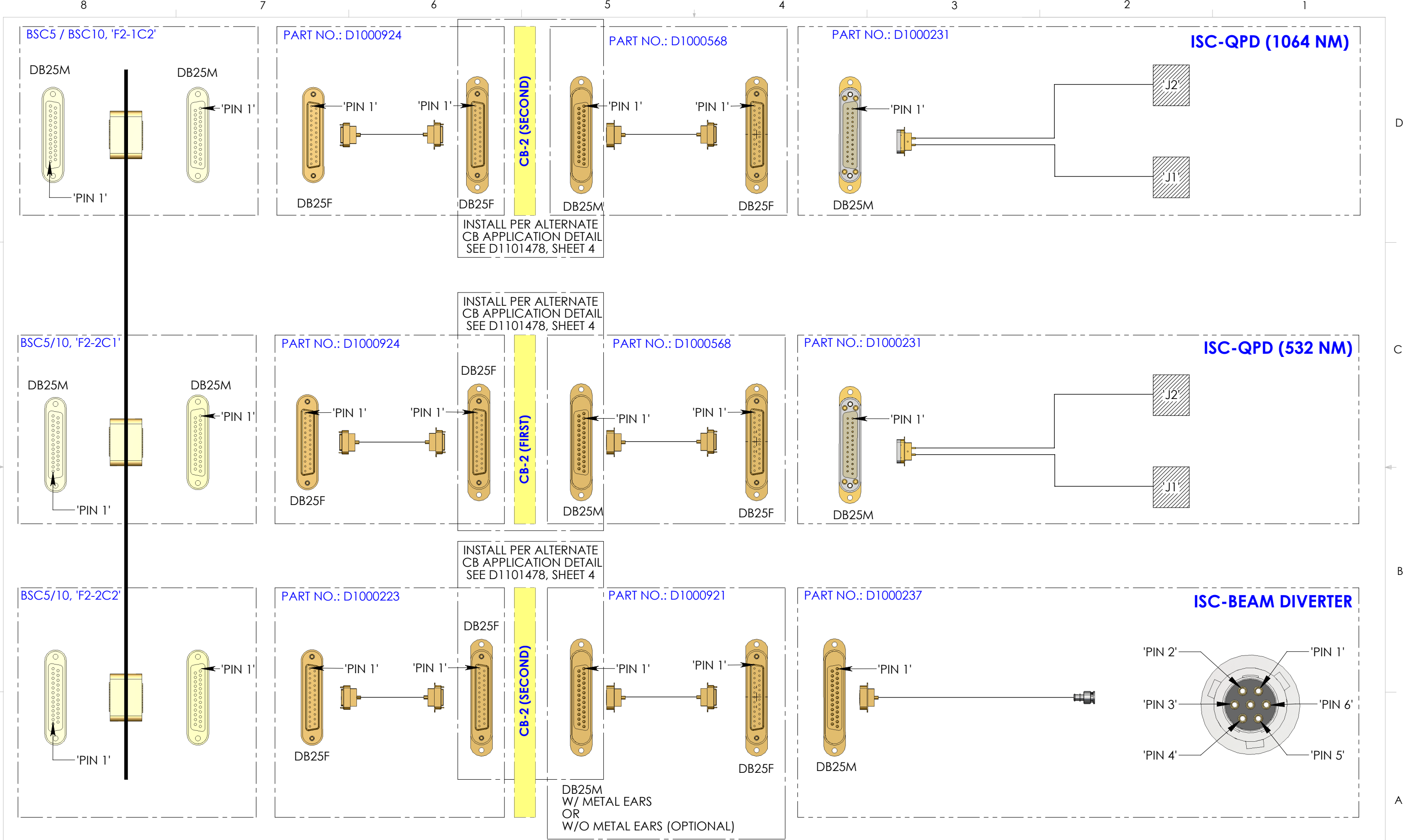

BSC5 / BSC10, INTERCONNECT CABLING DIAGRAM

PARENTHESIS DESIGNATIONS REFERENCE WIRING SCHEMATIC, SEE D1002741.
 PART NO. & REF. DES. SHOWN ARE FOR REFERENCE ONLY, AND DO NOT APPEAR ON CABLE ASSEMBLIES.

LIGO CALIFORNIA INSTITUTE OF TECHNOLOGY
 MASSACHUSETTS INSTITUTE OF TECHNOLOGY

SIZE	DWG. NO.	REV.
B	D1200111	v2
SCALE: 1:4	PROJECTION:	SHEET 10 OF 10