



LIGO Laboratory / LIGO Scientific Collaboration

LIGO-E1200322-V1

Advanced LIGO

5 Apr. 2012

**BSC2 L1 Requirements & Procedure, Cartridge Flight & Insertion
into BSC Chambers**

Sam Barnum, Calum Torrie, Eduardo Chavez

Distribution of this document:
LIGO Science Collaboration

This is an internal working note
of the LIGO Project.

California Institute of Technology
LIGO Project – MS 18-34
1200 E. California Blvd.
Pasadena, CA 91125
Phone (626) 395-2129
Fax (626) 304-9834
E-mail: info@ligo.caltech.edu

Massachusetts Institute of Technology
LIGO Project – NW17-161
175 Albany St
Cambridge, MA 02139
Phone (617) 253-4824
Fax (617) 253-7014
E-mail: info@ligo.mit.edu

LIGO Hanford Observatory
P.O. Box 1970
Mail Stop S9-02
Richland, WA 99352
Phone (509) 372-8106
Fax (509) 372-8137

LIGO Livingston Observatory
P.O. Box 940
Livingston, LA 70754
Phone (225) 686-3100
Fax (225) 686-7189

Fixtures 390165

<http://www.ligo.caltech.edu/>

82304HL

1. Reference Documents

D0900428 AdvLIGO Systems, BSC2-L1 Top Level Chamber Assembly

2. Rules about constructing BSC Installation Cartridges:

1. Items hung from the BSC-ISI that break the following rules will need to be removed, Or the cartridge will need to be maneuvered such that rules are maintained.
 - a. Items must fit within support tubes. See Clearance Zone On P2
 - b. Items must fit within all 4 Beams on the Test-Stand. Also see P2
- ② MAX Cartridge weight without 3PT Lifter is 9,500 lbs. *TEST Run Day Before* See detailed mass budget E1000202.
- ③ *possible Due to 90° rotation* CG of the Cartridge in X and Y, must be in the adjustable range of the lifting bar, or masses will need to be added back on, to balance the cartridge (Keel Mass will be removed). Balance may be achieved with temp mass on sidewalls if needed. (In this case, go below 9,500 lbs/4310 kg, then add back on to achieve XY balance).
4. Listing of items on ISI, ITM, ETM, BS/FM, TMS, that will need to be locked down when the cartridge is moved. And Cartridge Install procedure.

Conventions:

1. Views Labeled TOP are viewed from above looking down
2. Views Labeled Bottom are from below looking up.
3. Views Labeled Front are looking forwards from behind, so you see the back of the Cartridge.
4. Views Labeled Left are looking left from right side of the cartridge, so you see the right side.
5. All View Names correspond to the Views used in SolidWorks.
6. X-Y-Z Triad in each figure is relative to G1000125.
7. Cranes, and the direction of movement, are referred to by their compass orientation. At LHO: +X=North, +Y=West, LLO: +X=West, +Y=South.

Clearance zone layout for BSC2

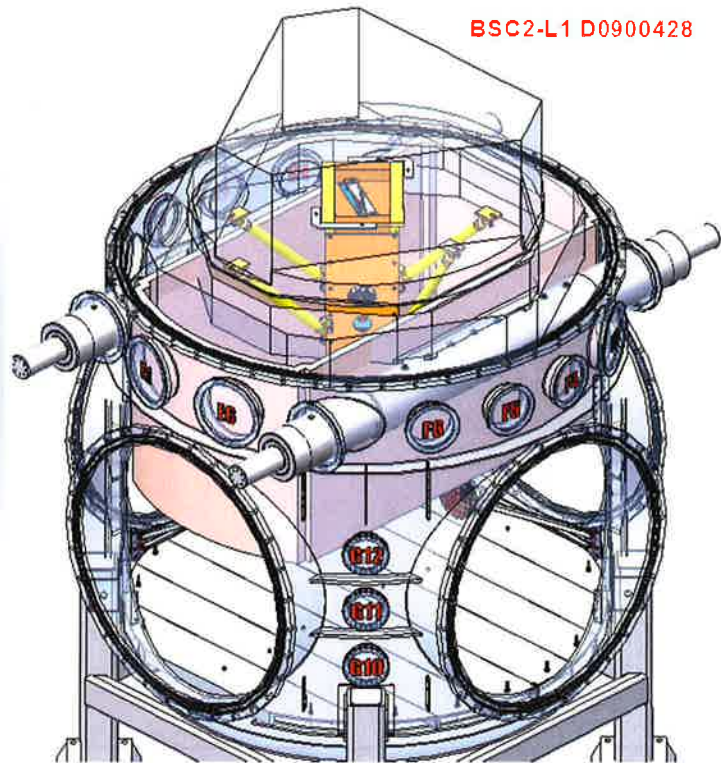
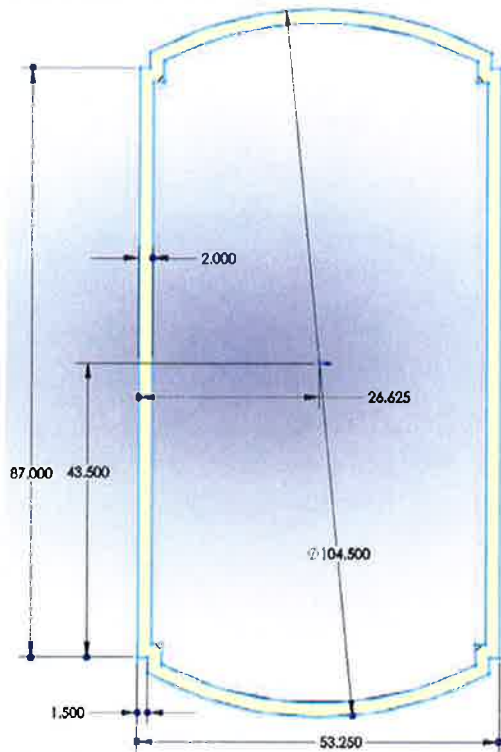

The Clearance Zone is a 2 inch wide area defined between the support tubes, and by the chamber shell. Any items on the cartridge that protrude partly into this zone should be considered for alteration or removal during install. **ANY ITEMS THAT PROTRUDE ALL THE WAY INTO, OR THRU, THE ZONE, MUST EITHER BE REMOVED OR ALTERED SO AS TO STAY CLEAR OF THE ZONE FOR INSTALL.**

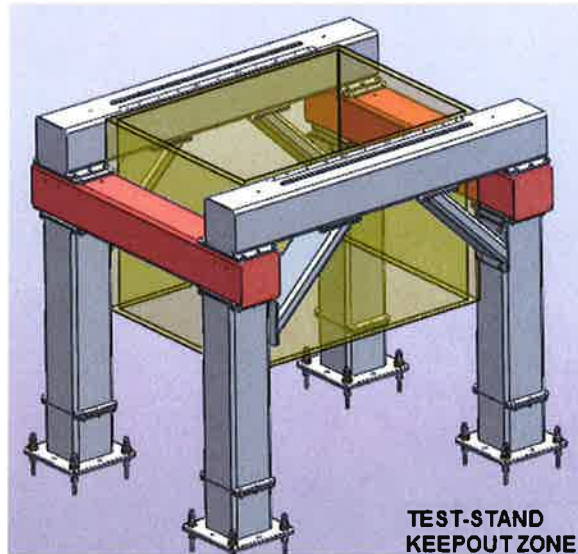
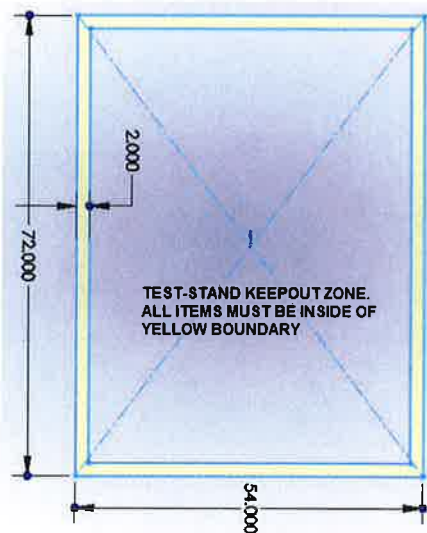

The following pages show the current expected configuration of the BSC2-L1 cartridge. Any issues with items violating the Clearance Zone are flagged, and possible cartridge maneuvering with the crane during install is suggested. The locations of the CGs is also shown with reference to the lifting bar on top of the cartridge.

Start D0900428 BSC2 L1 Considerations

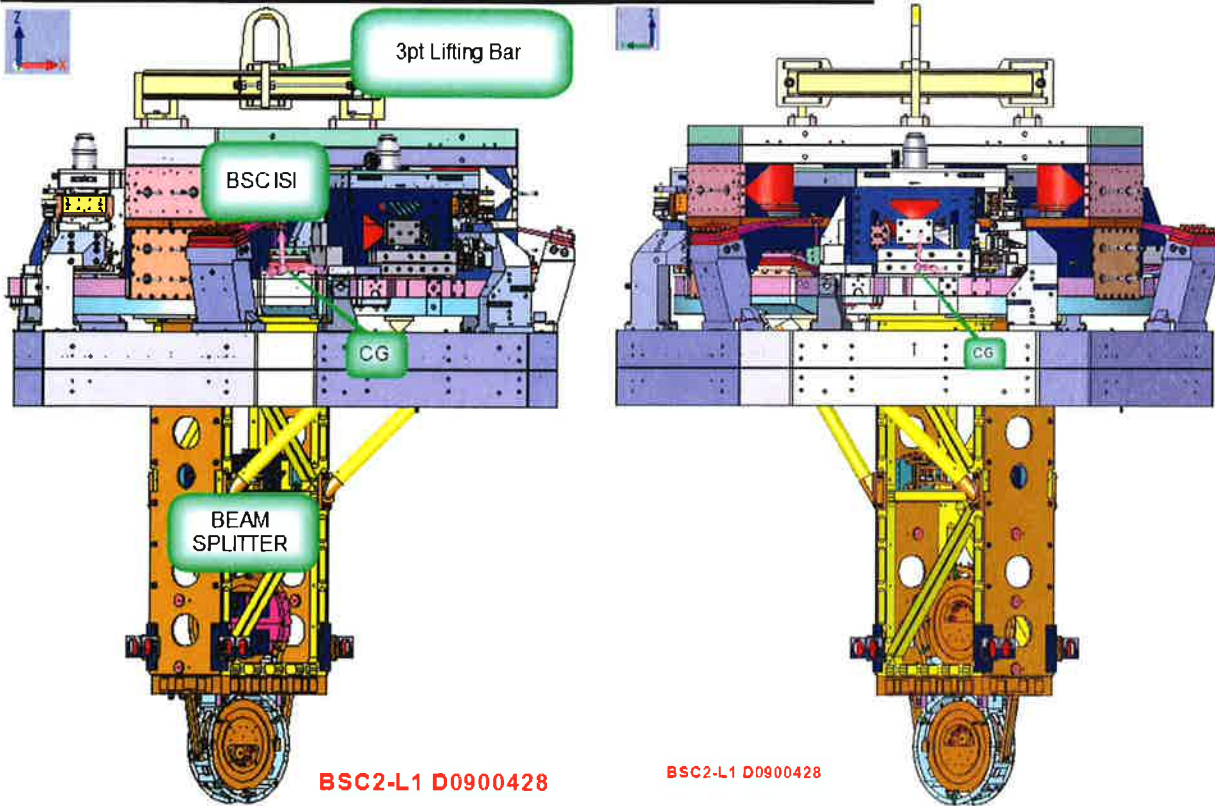

Cartridge installation of BSC2 without items that can't fit within Clearance zones. 3pt Lifting bar can cover the range of projected locations for the XY CG (with or without the ACB.)

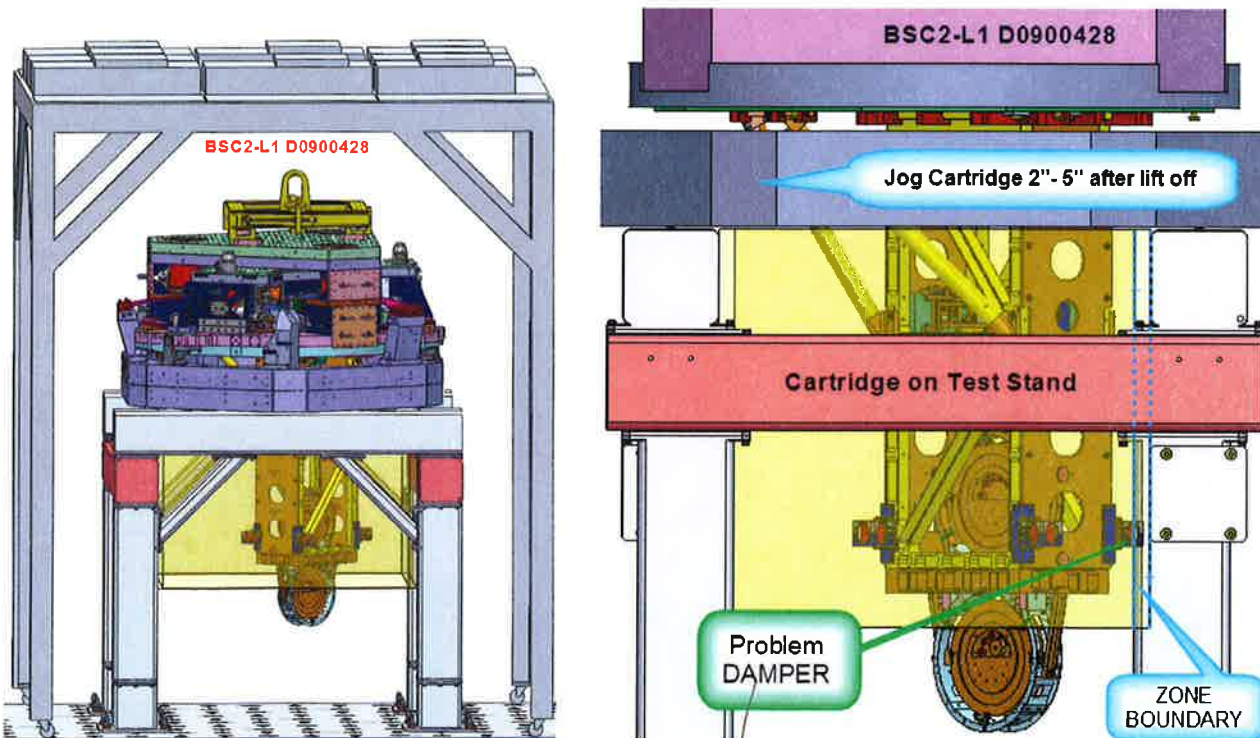

Cartridge will be centered on the Test Stand.

Identify

D0900428 BSC2-L1, Crane moves need to clear the Test Stand Clearance Zone.

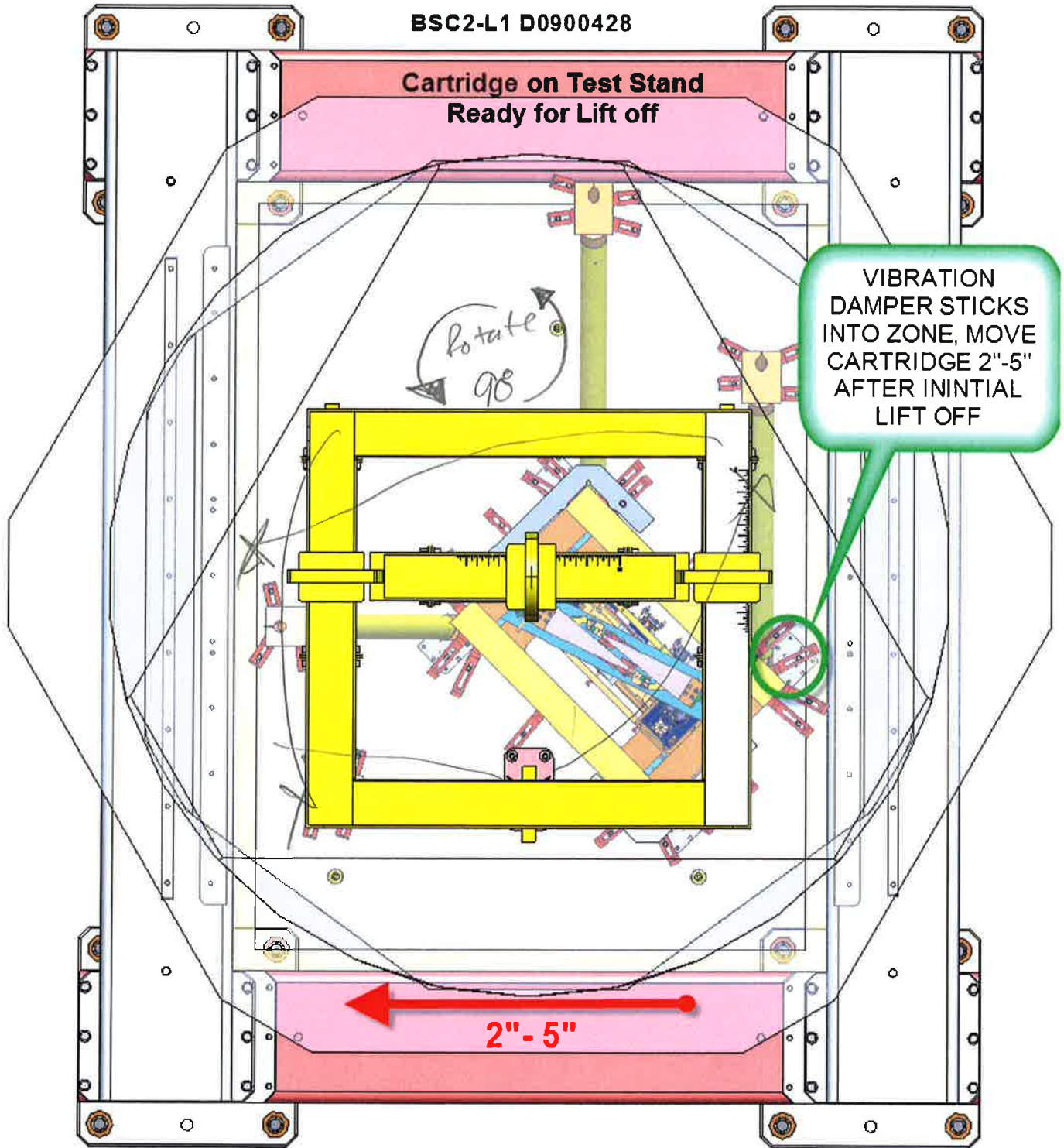

Circles in green indicate any protrusion into the keep out zone. Any global XY moves relative to the Test-Stand will depend on the orientation of the Test-Stand.

D0900428 BSC2-L1, Crane moves need to clear the Chamber Clearance Zone.

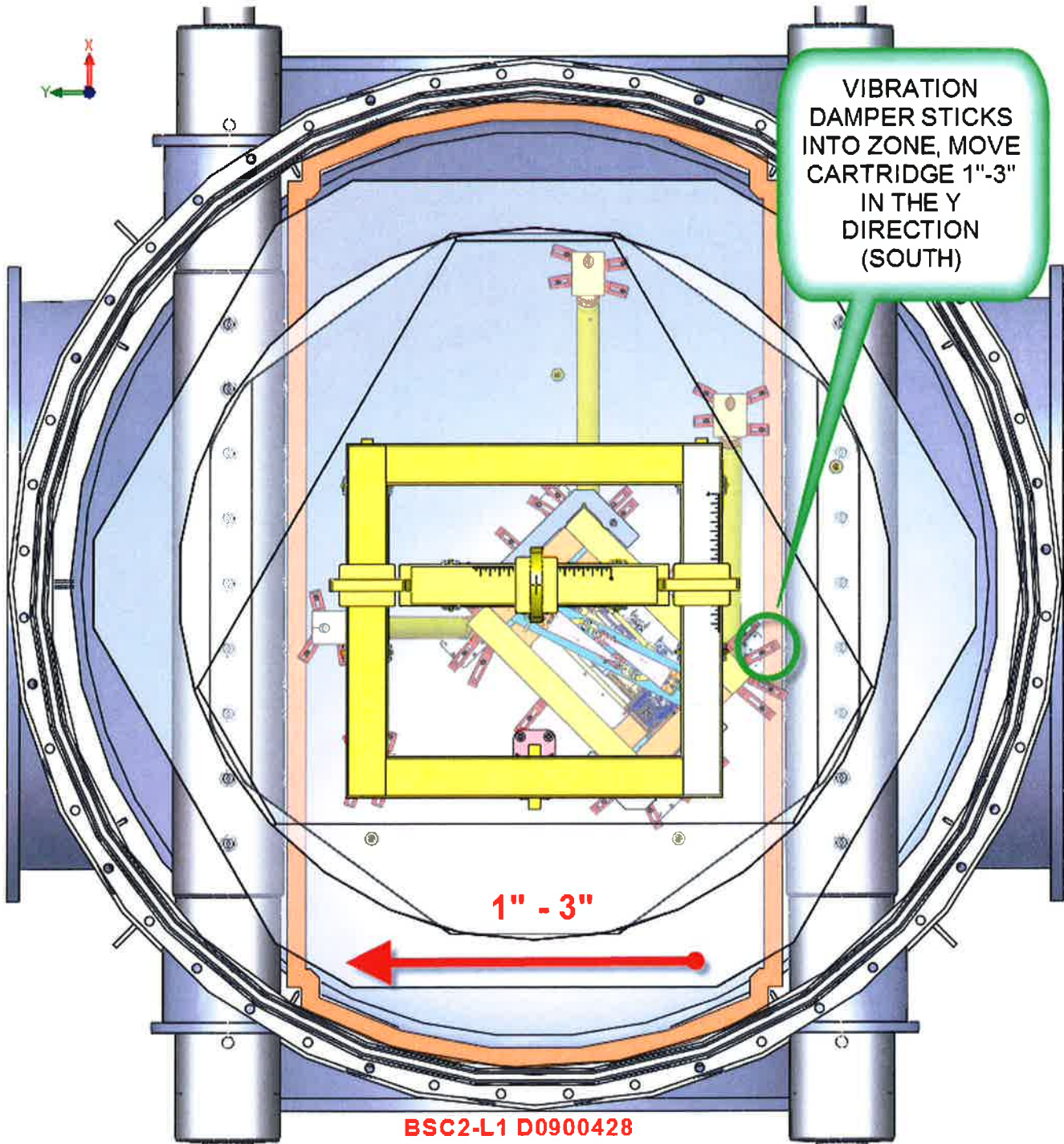

Before insertion a 1"- 3" move in the +Y (South) direction off center line is need. This will allow the vibration damper to clear the beam tubes, and still get ISI stage 0 into the chamber. (+Y is relative to the Global Coord. System as shown in G1000125.)

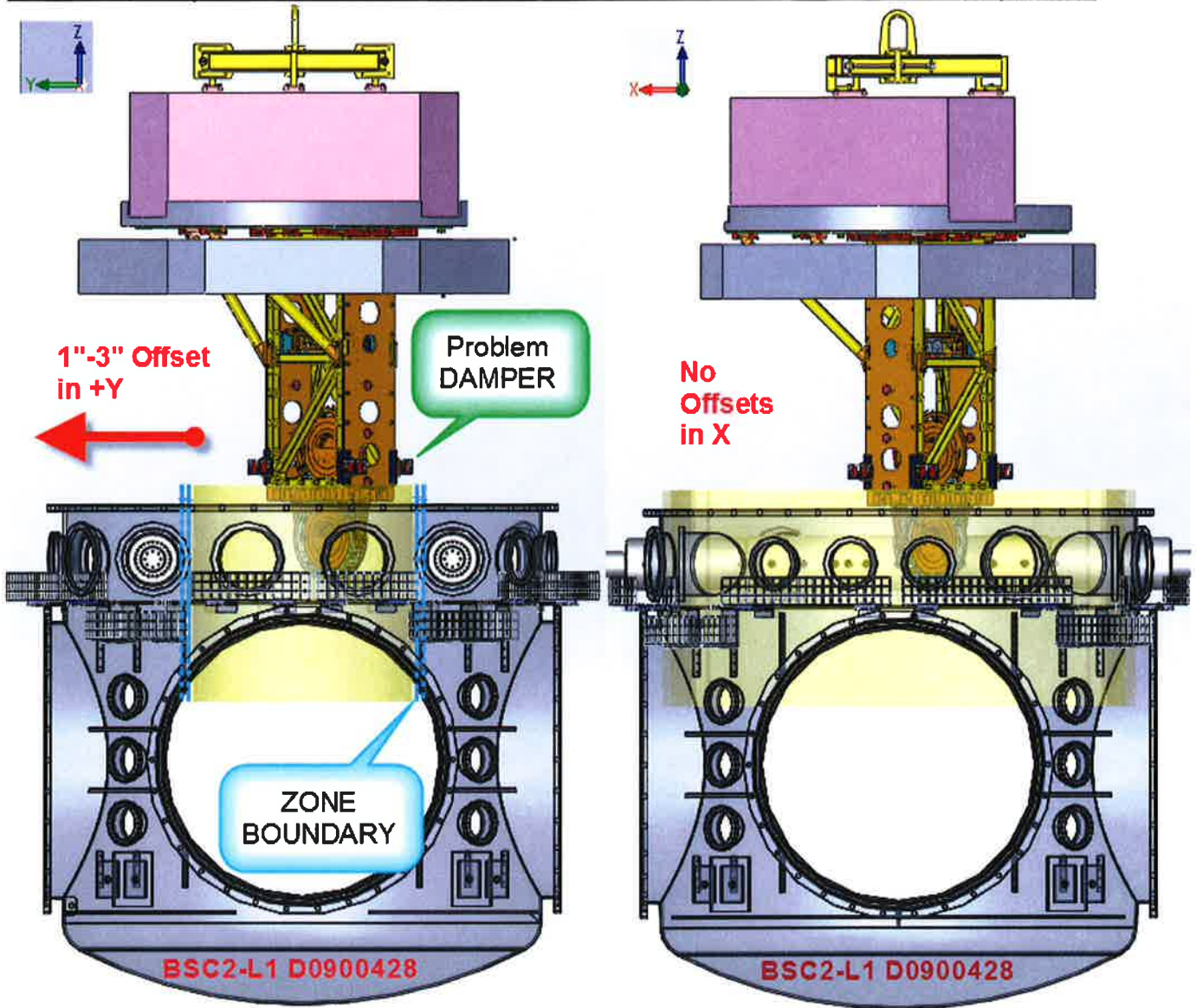

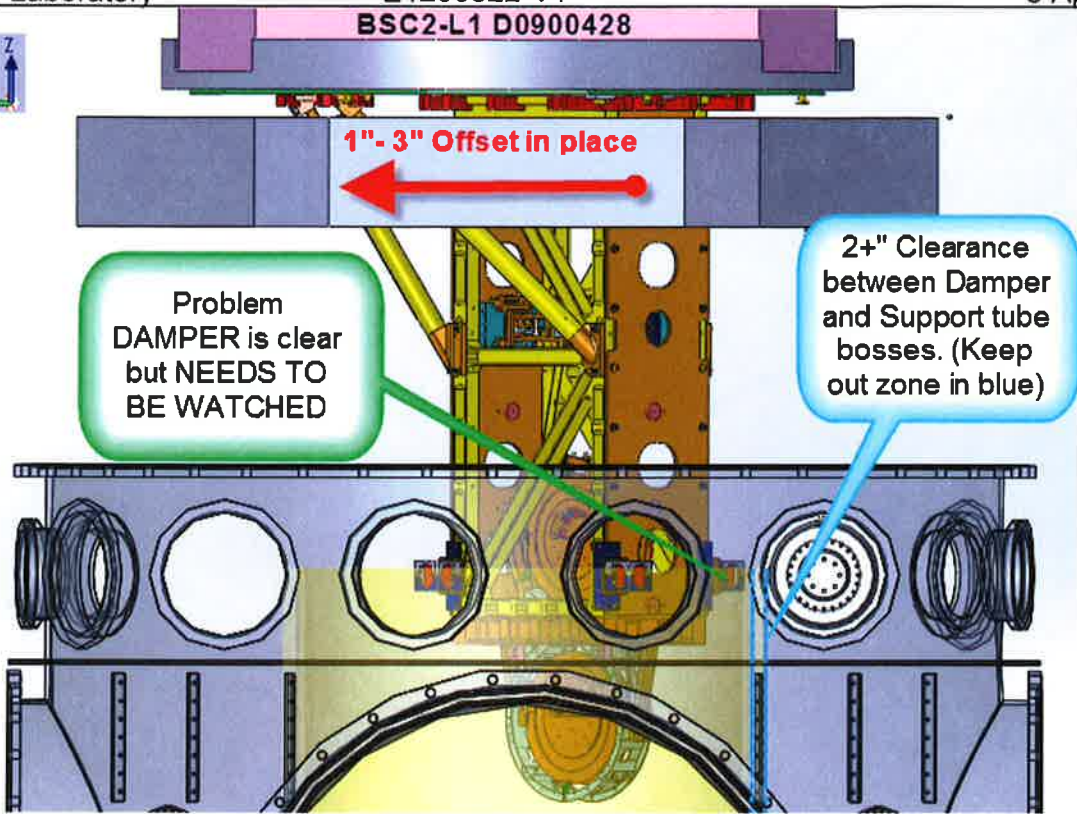

FILE MANAGER

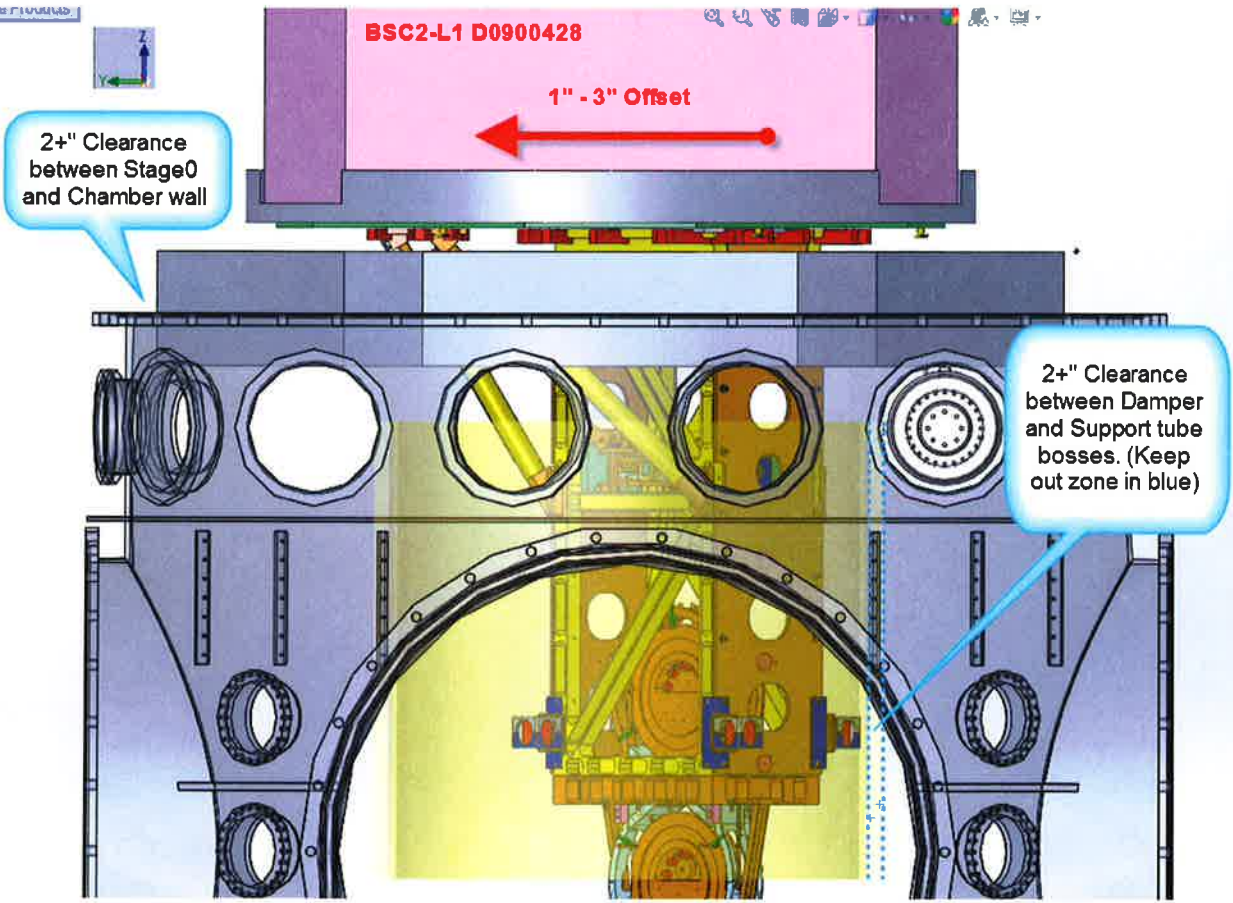

Locating the Bale pre-lift of the cartridge (Some adjustment will be needed)

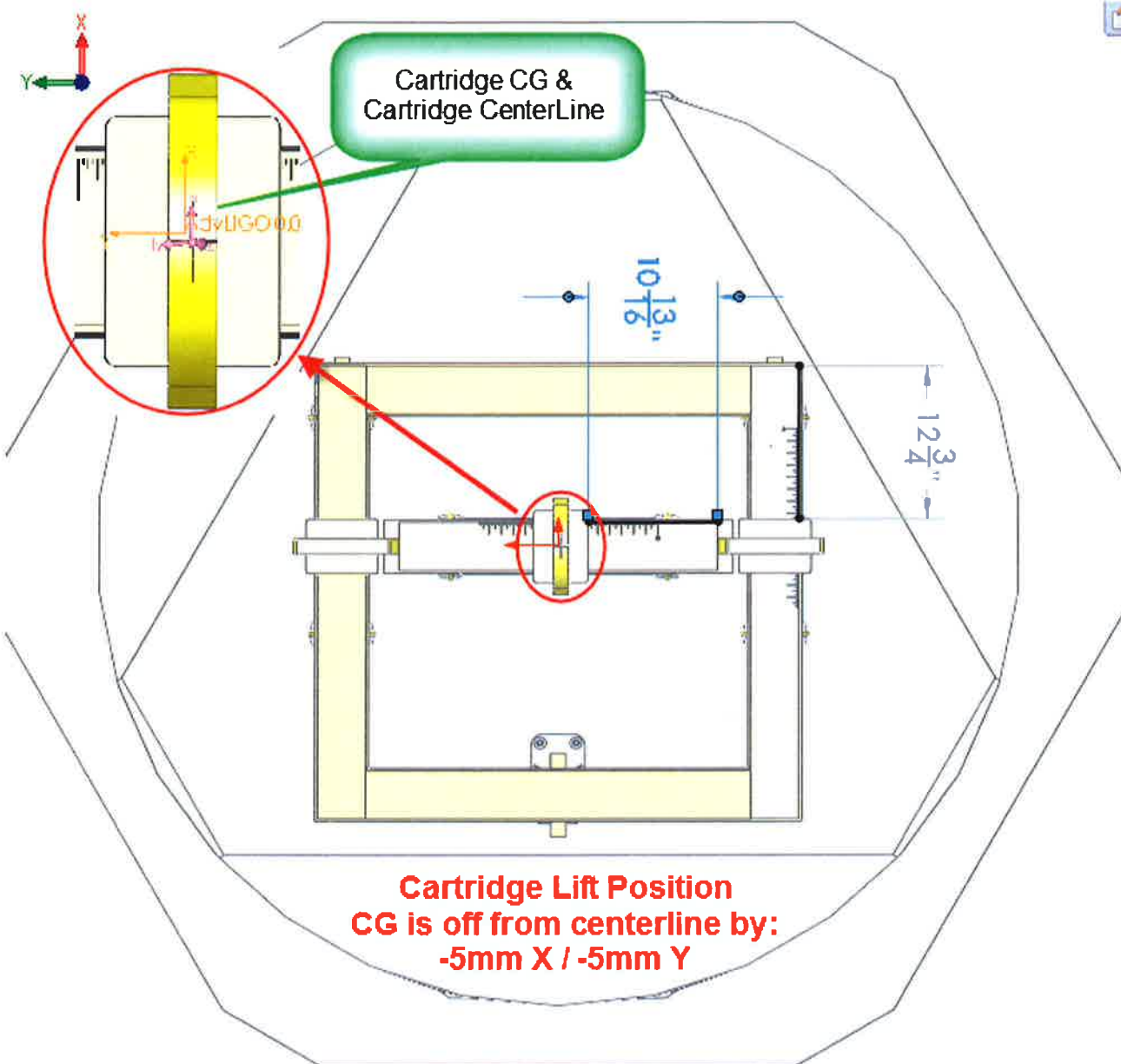

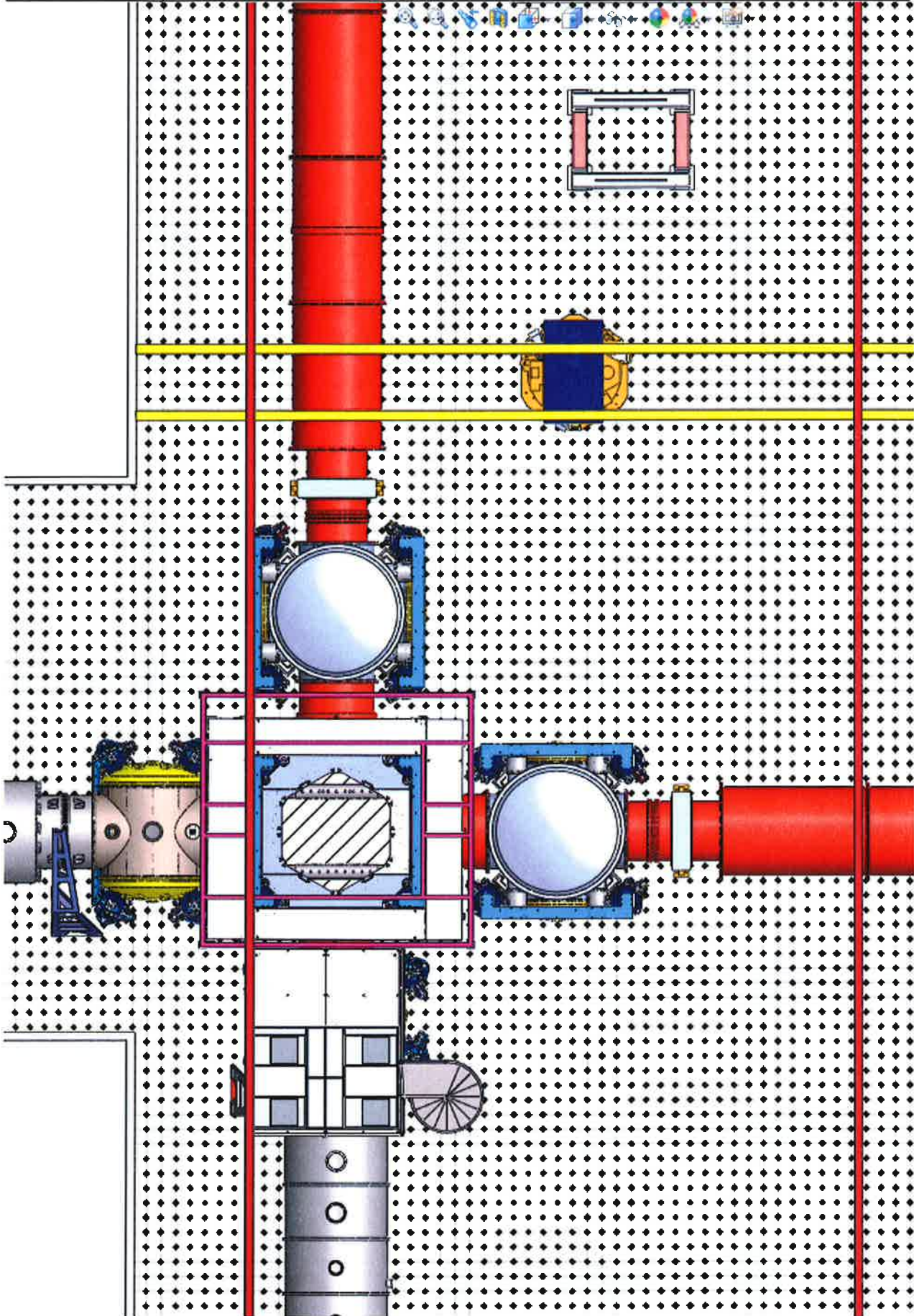

Items that will need to be locked down when the cartridge is moved:

1. **BSC-ISI:** (see [E1101037](#) sections 4.2)

completed, approved or checked by:
date:
comments (optional):

2. **BS/FM:** Final checks before moving the BS/FM ([T1100489](#)):

completed, approved or checked by:
date:
comments (optional):

Cartridge: Preparation for, and installation into Chamber:

aLIGO BSC ISI/Quad Install Procedure: (see [E1101037](#))

completed, approved or checked by:
date:
comments (optional):



LIGO Laboratory / LIGO Scientific Collaboration

LIGO-E1101037-v8

Advanced LIGO

29 February 2012

aLIGO BSC ISI/Quad Installation Procedure

Sam Barnum, Hugh Radkins, Ken Mason, Richard Mittleman

Distribution of this document:
Advanced LIGO Project

This is an internal working note
of the LIGO Laboratory

California Institute of Technology
LIGO Project – MS 18-34
1200 E. California Blvd.
Pasadena, CA 91125
Phone (626) 395-2129
Fax (626) 304-9834
E-mail: info@ligo.caltech.edu

LIGO Hanford Observatory
P.O. Box 1970
Mail Stop S9-02
Richland WA 99352
Phone 509-372-8106
Fax 509-372-8137

Massachusetts Institute of Technology
LIGO Project – NW22-295
185 Albany St
Cambridge, MA 02139
Phone (617) 253-4824
Fax (617) 253-7014
E-mail: info@ligo.mit.edu

LIGO Livingston Observatory
P.O. Box 940
Livingston, LA 70754
Phone 225-686-3100
Fax 225-686-7189



1 Overview

This document covers the procedure for the installation of the BSC ISI and Suspension Upper Structures into BSC chambers at the Hanford and Livingston facilities. This document along with the BSC Cartridge Installation Hazard Analysis E1100976-v2 must be read before beginning work on the installation.

Each of the BSC chamber installations will differ slightly depending on the orientation and payload. A separate document for each chamber will be required to outline the variations in weight, CG, and the flight path for insertion. For example LIGO document E1101016 contains BSC8 specific requirements and must be read prior to insertion of BSC8 ISI and payload into the H2 BSC8 chamber.

A note about clean room standards:

For a clean procedure all LIGO standards should be followed. Clean room garb including gloves should be worn when working with parts. Parts should be cleaned and handled according to the standard in LIGO document number E960022. Class A and Class B cleaning procedures and requirements on garbing and handling parts are specified in the LIGO documents M990034-C, LIGO Contamination Control Plan.

All tools that come in contact with the ClassA assembly should be cleaned to LIGO ClassB standards. The ISI should be handled under a portable clean room. Any time a part of the ISI assembly is not covered by the portable clean room or not being actively worked on it should be covered with appropriate clean covers. (C3 polyester or equivalent).

2 Related documents

- [LIGO-E1100763](#): aLIGO Installation Procedure: WBSC8
- [LIGO-E1100278](#): BSC6-H2, Requirements and Procedure, Cartridge Flight and Insertion into BSC Chamber, aLIGO.
- [LIGO-E1101016](#): BSC8-H2, Requirements and Procedure, Cartridge Flight and Insertion into BSC Chamber, aLIGO.
- [LIGO-E1101017](#): Cartridge Lifting Hardware, Loading Analysis.
- [LIGO-E1100976](#) BSC Cartridge Installation Hazard Analysis



- [LIGO-E1100988](#): Critical lift plan for the aLIGO BSC8 cartridge installation
- [LIGO-T1100406](#): Quad cartridge installation procedure check list
- [LIGO-T1100489](#): BS/FM installation lock-down procedure
- [LIGO-E1100841](#): TMS Transportation-Installation Restraint Procedure
- [LIGO-D1101307](#): TOOLING LAYOUT-aLIGO TMS Telescope Safety Supports
- [M1000360](#): Vent Isolatable Volumes
- [E1101162](#): BSC Dome Removal Procedure
- [D1102282](#): Cartridge Install Alignment Pin
- [LIGO-D1000756](#): Safety, Lift Hook Receiver
- [LIGO-G1000125](#): aLIGO ISI Orientations

3 Required Equipment List

Assume quantity of one (1) unless noted

- BSC Dome Cover for Dome
- BSC Dome-Tall for Chamber
- BSC-ISI C-3 Cover
- Wire Ties for Cabling (many)
- D1000753—Lift Hook Receiver (3)
- Bumax-88 3/8-16x2" SHCS & Washers (18)
- D1101583—BSC Cartridge Cover
- D1101836—Crane Debris Cover
- ELT 3pt Spreader Lift & Counterweight
- Grade 8 5/8-11x2" 12pt CS (3)
- 12pt 5/8x3/8 offset wrench
- 3/8"x125 ft-lb Torque wrench
- 3/8" breaker
- Load Cell, Shackles, & Hook
- D1102282--Alignment Pins (4) & 1/8" Hex Key
- Spring Clips (Many)
- Stage0/Support Tube Attach Hardware: Ag-Plated 3/8-24x2" SHCS & Washers(NAS 1149 3/8x.625x.063"thk flat washers) (14 each)
- 5/16 Hex Key wrench, sockets, & ratchets
- Inspection Mirrors (2)
- Headlamps, Flashlights, & Floodlight



4 Preliminary Tasks

Preliminary Tasks are those that can be done as soon as allowed based on readiness. For example, the ISI can be locked down as soon as testing is complete and signed off as required.

4.1 BSC8 Chamber Tasks

4.1.1 Work Platforms A B C & D should be in place around chamber.

4.1.2 Confirm HEPI Lock-down Set-screws are tight

4.1.3 Install and zero Dial Indicator Array on Locked HEPI

This might best be delayed until in-air cabling is moved to Chamber Feed-thrus

4.1.4 Vent Vacuum Section per M1000369

4.1.5 Remove Dome per E1101162 installing BSC Dome Tall C-3 cover over chamber.

Install Walking Plates. Since the walking plates attach to the chamber flange, our usual attachment of the C-3 Cover will be thwarted. Secure the cover to the Walking Plates or Railing Kick Plates with Spring Clips.

4.1.6 Install Alignment Pins D1102282 in BSC Support Tubes.

Place the pins in the Support Tubes with the obscuring of vision from the Cartridge (Suspensions) in mind. That is, some pins may be visual for the landing near the middle or end of the Tubes. Position appropriately

4.1.7 Remove Work Platform Handrails

4.1.8 Lower Cleanroom to minimum height

4.2 Cartridge at Test-Stand Tasks

4.2.1 Lock optic suspension assemblies per T1100406.

4.2.2 Lock all Six Lockers between Stage0 and Stages 1 & 2.

Lock Stage1 first corners 1, 2, then 3 in sequence; then lock Stage2 corners 1, 2, & 3. Turn locker out until the faces almost touch (Do not make tight). Endeavor to not move the suspended stage being locked while turning the Locker wheel.



4.2.3 Disconnect all wiring and secure with ClassB cable or wire ties.

4.2.4 Remove racks, cables, feed-thrus that will be in the way

4.2.5 Remove Keel Masses^(Dummy Mass) (and Viton pads) from top of BSC-ISI.
(Note location for re-assembly in the chamber.) ~~Not Needed due to dummy Mass.~~

4.2.6 Make a final check to ensure that there are no loose parts on the stages or masses, which may become dislodged when the ISI is moved.

Document this inspection with photos.

4.2.7 Attach the three (3) Lift Hook Receivers^(Blocks) (D1000753) on the ISI Keel-plate, if not already present (See D1000756 for layout,) torque 3/8"-16x2" Bumax-88 bolts to 15 ft-lb per load analysis E1101017.

4.2.8 Cover ISI with BSC-ISI.Cover.

4.2.9 Remove nuts securing ISI to Test Stand

4.3 Other

4.3.1 Clear cabling on floor etc to allow cleanroom to move.

4.3.2 ...

5 General Process of Installation

5.1 Pre-Flight

Tasks here can be done with Cleanroom in place



5.1.1 Cover suspended items from below with covers provided by Sub System Teams.

5.1.2 Position C3 cloth Cartridge Cover on top of cartridge.
(D1101583)

5.1.3 Position C3 cloth 3pt lifter undercover over cartridge cover.
(D1101836)

5.1.4 Attach 3pt lifter (D1003140) to Crane with Load Cell in line. Level lifter with counterweight. Include Load Cell and hook in lift gear

5.2 Test-Flight

These tasks require the cleanroom to be moved. The Cartridge while clothed in C-3 will be accumulating dust and efforts should be made to expedite this period.

5.2.1 Move Cleanroom to allow clear removal of Cartridge.

5.2.2 Crane balanced 3pt Lifter (D1003140) to above Cartridge

5.2.3 Attach 3pt Lifter to Lift Hook Receivers; torque 5/8"-11 Grade8 bolts to 100ft-lb.

Hover lifter above Receivers to facilitate a smooth bolt threading. With bolts well in, land the lifter and torque.



- 5.2.4 Remove counterweight from 3 pt Lifter.
- 5.2.5 Lower crane enough to free connection to Lifter—Adjust crane position to TDC
- 5.2.6 Lift cartridge assembly as little as required above test stand and level suspended Cartridge to insure level insertion into chamber. If not level to $\pm 1/4$ " wrt Test Stand when lifted, set cartridge back down and adjust bale location. Repeat as necessary.
- 5.2.7 Check Cartridge weight: Lift cartridge from test-stand with load cell and crane approximately 1-2 inches, If load cell starts to exceed 10,000lb, stop, and set cartridge back down. Remove weight and try again. Note final total weight, set back down and remove load cell.

5.3 Flight to Chamber

5.3.1 Reconnect Crane to Lifter

Without the load cell and just the crane hook, reattach to lifter and again, get to TDC position. Hoist a few inches.

- 5.3.2 Hold in this position for several minutes and watch for drifting, creep, or any other unsafe condition.
- 5.3.3 Lift Cartridge high enough to pull big cover down around cartridge and between the cartridge and test stand. This may require stages of raising the Cartridge and pulling down the cover so that the cover does not touch the floor. Tie off open end of cover under the full Cartridge.
- 5.3.4 Orient the Cartridge as required for installation per G1000125 and raise cartridge up to height to clear BSC Clean-room (max height)
- 5.3.5 Move crane to a point centered above BSC chamber and clean room as shown in Fig. 1.[From what I can see this does not show the Cartridge over the chamber but don't worry].

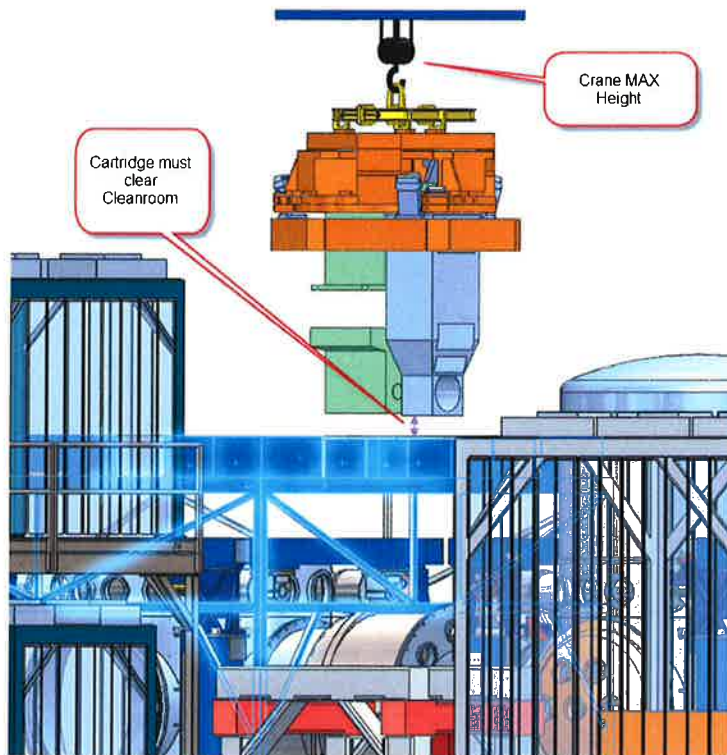

Fig 1

5.4 Flight Path at the Chamber



LASER INTERFEROMETER GRAVITATIONAL WAVE OBSERVATORY

This requires personnel in the Cleanroom on the Walking Plates possibly with fall arrest equipment. The raising of the cleanroom, lowering of the Cartridge, and opening of the sock may be iterative. The authors' intent is to not have the BSC chamber open when the cleanroom ceiling is open.

5.4.1 Raise BSC clean room back to max or required height and install railings onto Work Platforms (Fig. 2).

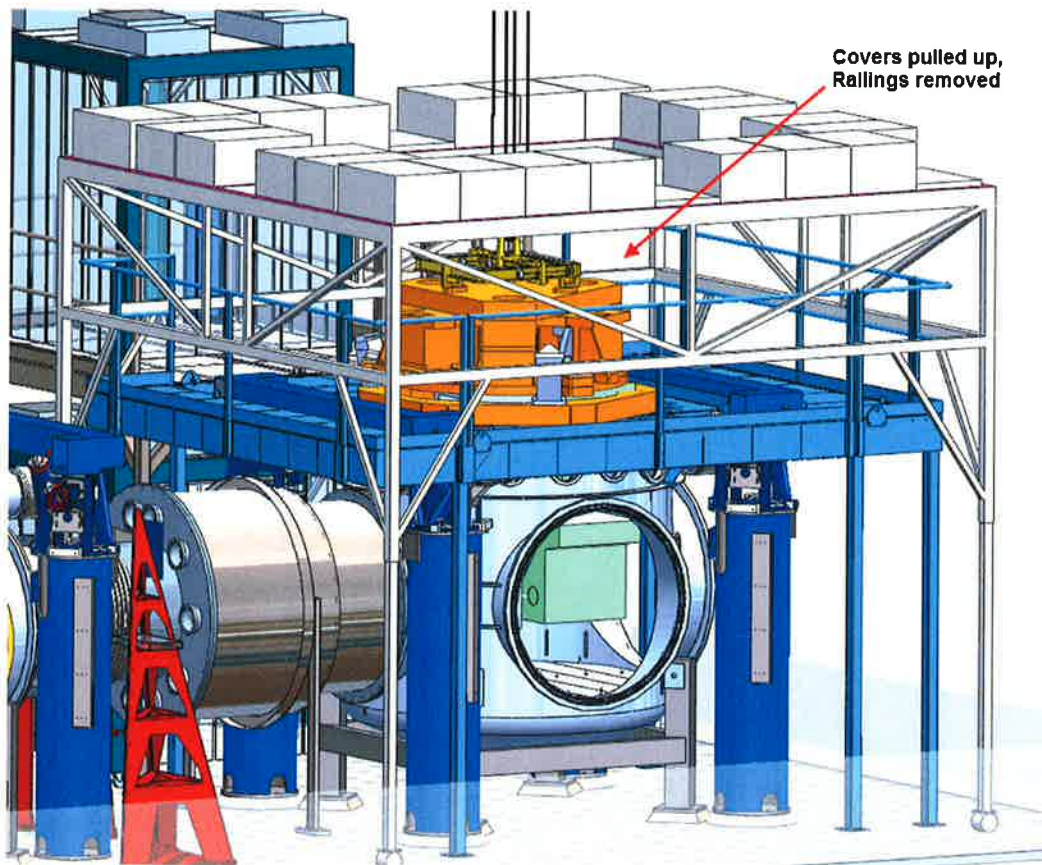

Fig 2.

5.4.2 Lower the cartridge just far enough that the cleanroom ceiling can be secured around the lift hook sealing the cleanroom.

5.4.3 When Dust counts are low enough, pull up Covers as needed to expose ISI Stage0/Support Tube contact.

This should only be the Cartridge Cover but it is tied below—may require someone in chamber. Roll this up as possible, raising and then lowering the Cartridge as required.



5.4.4 Raise the cartridge enough to remove the chamber cover—do so.

May have to tango with the chamber and the Cartridge covers depending on proximities to avoid inappropriate touching.

5.4.5 Lower the cartridge enough to evaluate its position wrt the chamber and potential interferences.

5.4.6 Continue lowering cartridge shifting horizontally as required in Chamber specific *Cartridge Flight & Insertion* Document until all obstructions are cleared.

5.4.7 Center position and continue lowering adjusting position as proximity to Support Tubes improves feedback.

5.5 Flare, Rollout, & Tiedown

At some point, likely even prior to now, someone will be needed in the chamber assisting in guiding the landing as view of the alignment pins/Stage0 holes will not be easy from above.

Two persons will be required in the chamber door flanges outside the Support Tubes.

5.5.1 Slip ISI Stage0 ever so smoothly over alignment pins and hold ISI just above the tubes to allow movement.

5.5.2 Install (14) 3/8-24 x 2" silver plated SST cap screws with washers through stage 0 into the tube removing the guide pins last.

It will be necessary to install these screws from inside the BSC chamber. Remove the alignment pins and replace with screws. Try to lower the cartridge in small increments such that the screws can all be threaded in by hand.

5.5.3 Lower the cartridge assembly so that it is supported by the support tubes.

If gaps remain between the Support Tubes and ISI Stage0 (might be difficult to assess) raising a Support Tube with HEPI 'Set Screws' may be called for.

When all gaps are closed, torque bolts to 23 ft-lbs.

Remove all load from Crane and do final torquing.



5.6 Debrief

- 5.6.1 Break loose but don't remove the three (3) 5/8-11 bolts from lifter/base plates
- 5.6.2 Disconnect Base Plates (D1000753) from Keel and lift high enough to cover ISI with C3 (BSC Dome Tall). Use the Crane Debris Cover to cover the lifter by folding it up over the lifter. Open cleanroom ceiling and hoist 3pt lifter clear. Close up clean room and finish removing C3 covers. Secure 3pt lifter, Base Plates and hardware.

6 Post Install

Work in progress below as evident--HR

1. Check level of stage 0 using a clean precision level. Adjust with HEPI if necessary until stage 0 is level to within .4 mrad.
2. Replace keel masses and viton pads on top of stage 2 per E0900357.
3. Attach in vacuum cabling to all sensors, actuators and payload. Be careful not to bend pins or put force on feedthroughs.
4. Install other payloads as specified in the chamber specific procedure.
5. Unlock all six lockers between stage0 and stages 1 & 2.
6. Rebalance and continue testing per LIGO E1000304.

6.1



SPECIFICATION

**Critical Lift Plan for the aLIGO
BSC2-L1 Cartridge Installation**

AUTHOR(S)	DATE	Document Change Notice, Release or Approval
A. Holland	16 July 2012	V1

Objective and Scope

This document addresses critical issues in the lift of the cartridge (SEI/SUS/AOS) payload from LLO test stand, to insertion in BSC2-L1. Further documentation on overarching cartridge procedures can be found in related documents below. The critical lift document is not intended to supersede E1200322, aLIGO Installation Procedure: BSC2 (or documents called out therein), but instead to call out critical safety items on the lift from test stand to chamber.

1. Related documents

LIGO-E1200329: aLIGO Installation Procedure: LBSC2

LIGO-E1200322: BSC2-L1 Requirements and Procedure, Cartridge Flight and Insertion into BSC Chamber

LIGO-E1200344: BSC Cartridge General Install Procedure aLIGO

LIGO-E1101037: aLIGO BSC ISI/Quad Installation Procedure

LIGO-E1200327-v4: BSC2-L1 Cartridge Installation Hazard Analysis

2. Required Personal Protection Equipment (PPE)

1. Hard hat
2. Safety glasses
3. Steel toe shoes/boots

3. Procedure

1. Hold a pre-lift team meeting ensuring that all personnel have reviewed and understand the procedure, hazard analysis, and this lift plan for the ISI lift from the test stand to the chamber.
2. Task leader should verify that all persons involved with the lift are wearing the appropriate PPE assigned for the lift.
3. Task leader should ensure that all necessary tools and equipment should be staged and ready in the work area prior to any lift being made. Reference LIGO-E1101037: aLIGO BSC
4. Task leader and safety officer shall ensure that all personnel not involved in the lift leave the area or stay at a safe distance until the lift has been completed. If necessary, barricades and safety warning personnel can be used to control access to the area.
5. Verify that the lift area, path of load travel, and BSC2 chamber areas are clear of extraneous equipment and personnel. Particular attention must be paid to the flight path of the cartridge, owing to potential interferences from neighboring cleanrooms, chambers and vacuum equipment such as annulus ion pump tubing.



SPECIFICATION

Document No Rev.
LIGO-E1200328 V1

Sheet 3 of 3

Critical Lift Plan for the aLIGO BSC2-L1 Cartridge Installation

Task Leader: Jeremy Birch (Initial all items once completed)
(Print Name)

Pre-lift checklist:

1. Verbally confirm that team members have introduced themselves to each other and that all have read the procedure, are aware of the hazards and are wearing correct PPE. JB
2. Verbally remind team members of the stop work policy. JB
3. Verbally remind team members to not stand under or place limbs under the load once it has been lifted. JB
4. Confirm that the crane and lifting gear have been inspected and documentation completed. JB
5. Confirm that the cartridge is cleared and disconnected from any cables, etc. JB
6. Confirm that all personnel not involved in the task have been removed from the work area and that the control room operator has been notified of the impending lift. JB

Post load-test checklist:

1. Confirm with team members than no interferences were noted during the short lift. JB
2. Have at least two team members verbally confirm reading from load cell. JB
3. Verify that lift area, path of travel, and landing area is clear of extraneous equipment and personnel. JB
4. Remind personnel again not to stand of place limbs while the load is suspended with the crane. JB

Post-lift checklist:

1. Check that all lifting equipment has been removed from the cartridge. JB



LIGO Laboratory / LIGO Scientific Collaboration

LIGO-E1200322-V2

Advanced LIGO

5 Jul. 2012

**BSC2 L1 Requirements & Procedure, Cartridge Flight & Insertion
into BSC Chambers**

Sam Barnum, Calum Torrie, Eduardo Chavez

Distribution of this document:
LIGO Science Collaboration

This is an internal working note
of the LIGO Project.

California Institute of Technology
LIGO Project – MS 18-34
1200 E. California Blvd.
Pasadena, CA 91125
Phone (626) 395-2129
Fax (626) 304-9834
E-mail: info@ligo.caltech.edu

Massachusetts Institute of Technology
LIGO Project – NW17-161
175 Albany St
Cambridge, MA 02139
Phone (617) 253-4824
Fax (617) 253-7014
E-mail: info@ligo.mit.edu

LIGO Hanford Observatory
P.O. Box 1970
Mail Stop S9-02
Richland, WA 99352
Phone (509) 372-8106
Fax (509) 372-8137

LIGO Livingston Observatory
P.O. Box 940
Livingston, LA 70754
Phone (225) 686-3100
Fax (225) 686-7189

<http://www.ligo.caltech.edu/>

1. Reference Documents

D0900428 AdvLIGO Systems, BSC2-L1 Top Level Chamber Assembly

2. Rules about constructing BSC Installation Cartridges:

1. Items hung from the BSC-ISI that break the following rules will need to be removed, Or the cartridge will needed to be maneuvered such that rules are maintained.
 - a. Items must fit within support tubes. See Clearance Zone On P2
 - b. Items must fit within all 4 Beams on the Test-Stand. Also see P2
2. MAX Cartridge weight without 3PT Lifter is 9,500 lbs. See detailed mass budget *E1000202*.
3. CG of the Cartridge in X and Y, must be in the adjustable range of the lifting bar, or masses will need to be added back on, to balance the cartridge (Keel Mass will be removed). Balance may be achieved with temp mass on sidewalls if needed. (In this case, go below 9,500 lbs/4310 kg, then add back on to achieve XY balance).
4. Listing of items on ISI, ITM, ETM, BS/FM, TMS, that will need to be locked down when the cartridge is moved. And Cartridge Install procedure.

Conventions:

1. Views Labeled TOP are viewed from above looking down
2. Views Labeled Bottom are from bellow looking up.
3. Views Labeled Front are looking forwards from behind, so you see the back of the Cartridge.
4. Views Labeled Left are looking left from right side of the cartridge, so you see the right side.
5. All View Names correspond to the Views used in SolidWorks.
6. X-Y-Z Triad in each figure is relative to *G1000125*.
7. Cranes, and the direction of movement, are referred to by their compass orientation. At LHO: +X=North, +Y=West, LLO: +X=West, +Y=South.

Clearance zone layout for BSC2

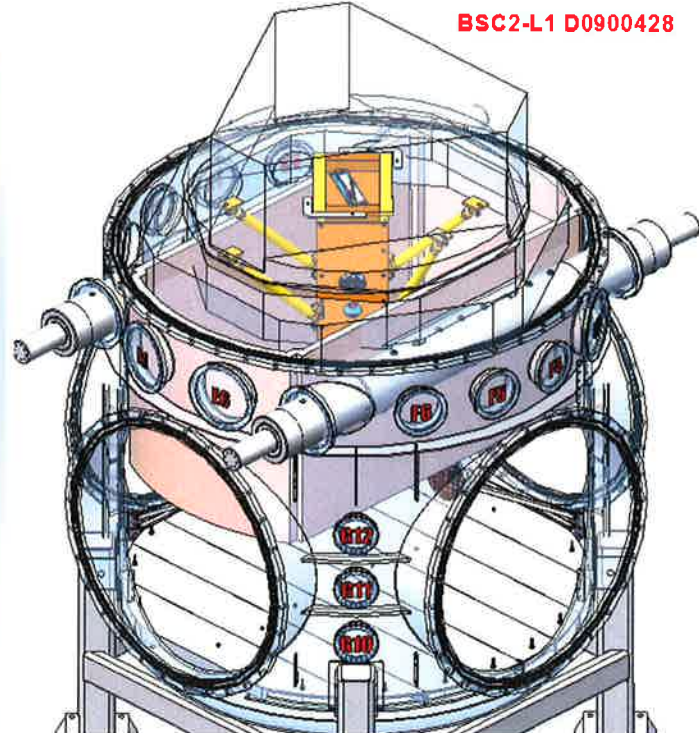
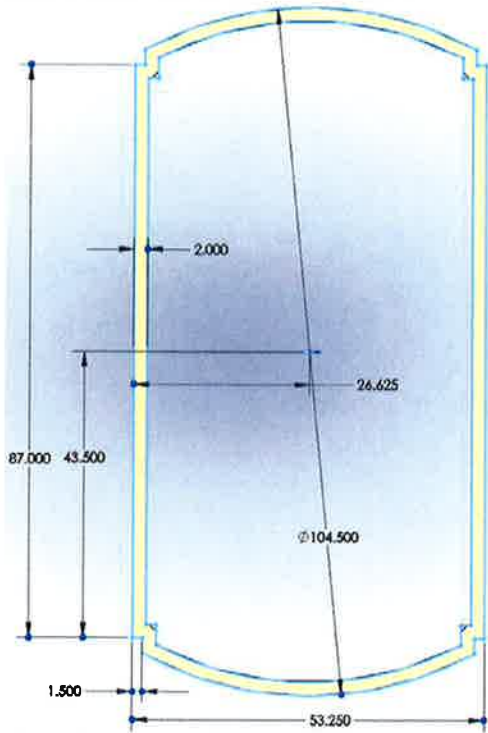

The Clearance Zone is a 2 inch wide area defined between the support tubes, and by the chamber shell. Any items on the cartridge that protrude partly into this zone should be considered for alteration or removal during install. **ANY ITEMS THAT PROTRUDE ALL THE WAY INTO, OR THRU, THE ZONE, MUST EITHER BE REMOVED OR ALTERED SO AS TO STAY CLEAR OF THE ZONE FOR INSTALL.**

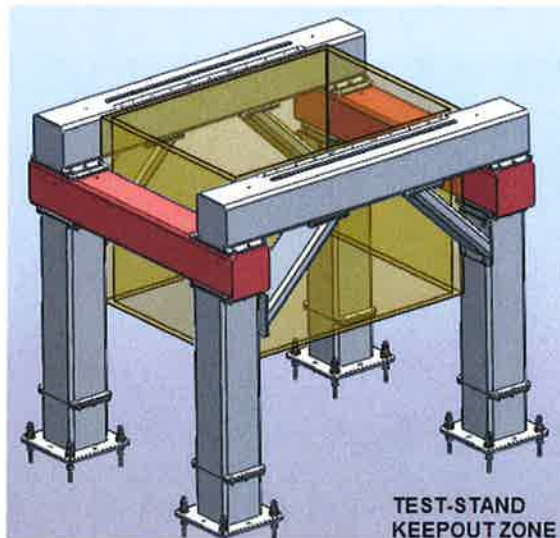
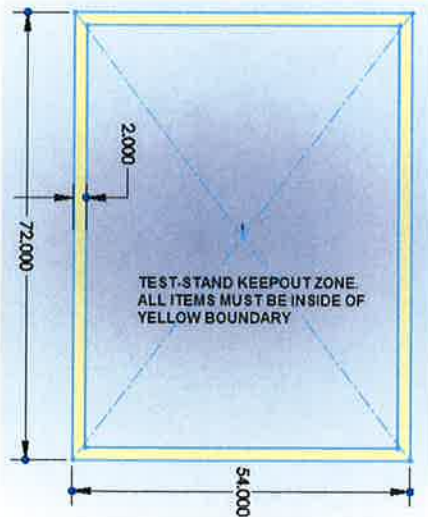

The following pages show the current expected configuration of the BSC2-L1 cartridge. Any issues with items violating the Clearance Zone are flagged, and possible cartridge maneuvering with the crane during install is suggested. The locations of the CGs is also shown with reference to the lifting bar on top of the cartridge.

Start D0900428 BSC2 L1 Considerations

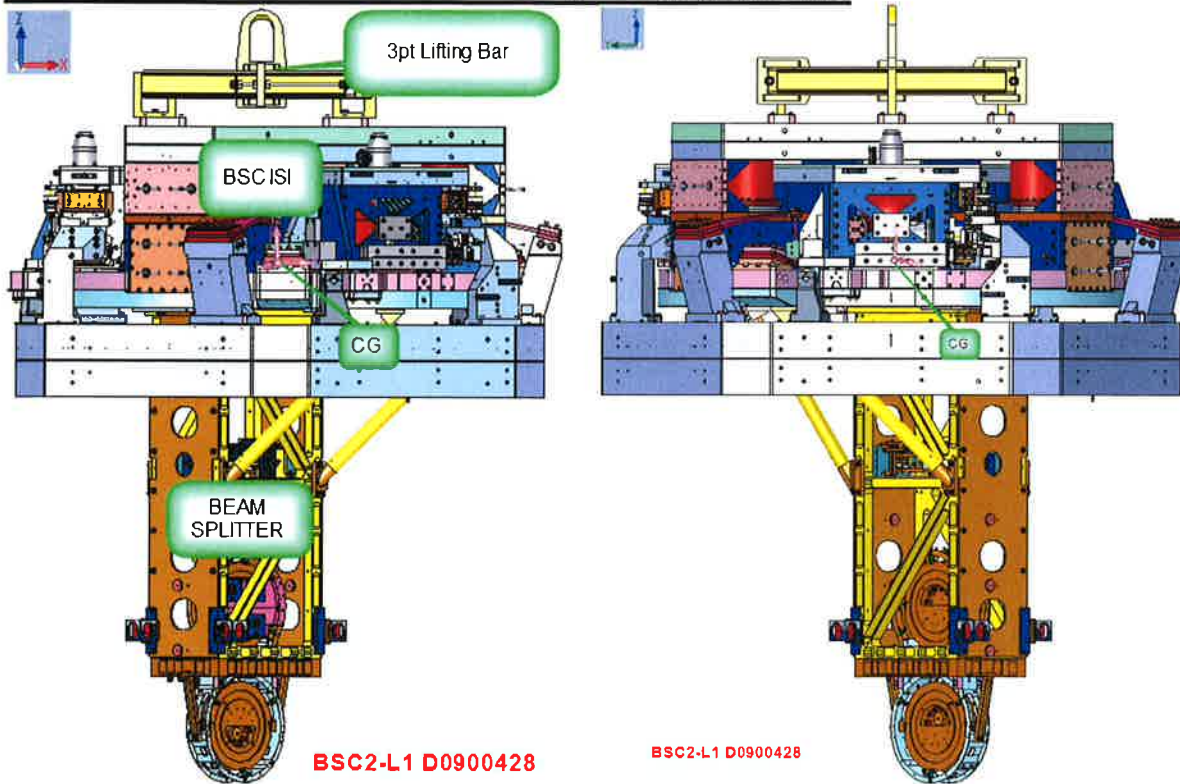

Cartridge installation of BSC2 without items that can't fit within Clearance zones. 3pt Lifting bar can cover the range of projected locations for the XY CG (with or without the ACB.)

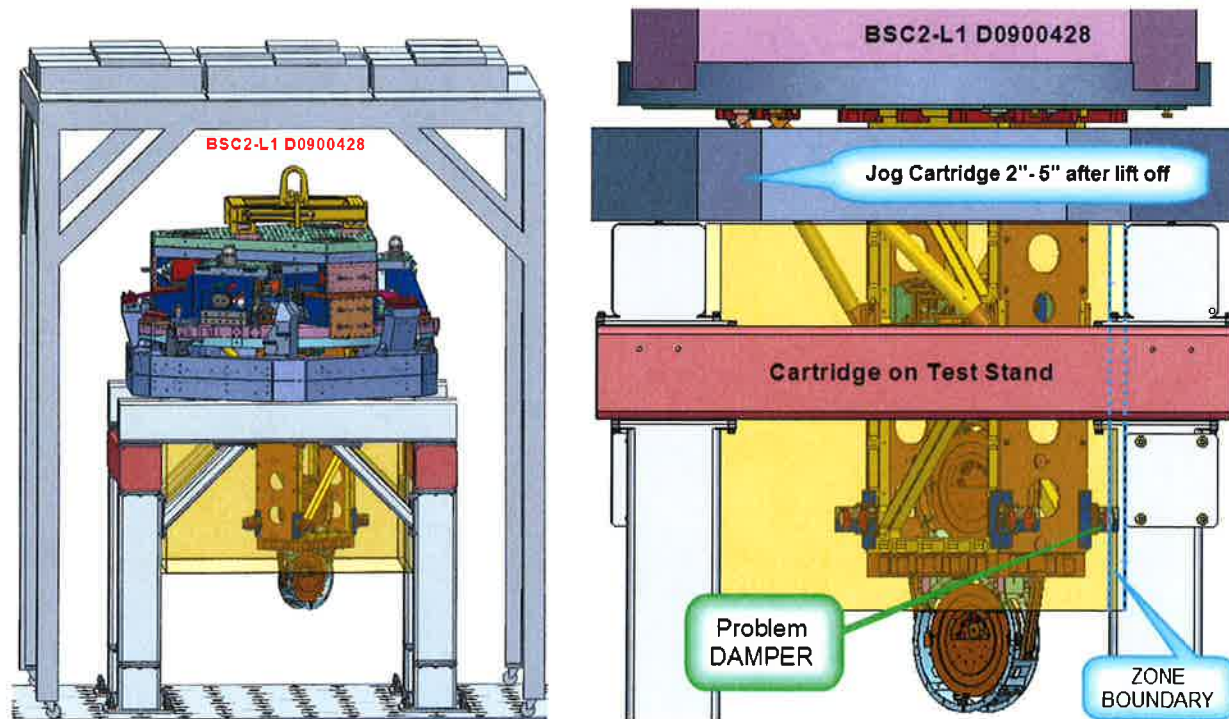

Cartridge will be centered on the Test Stand.

D0900428 BSC2-L1, Crane moves need to clear the Test Stand Clearance Zone.

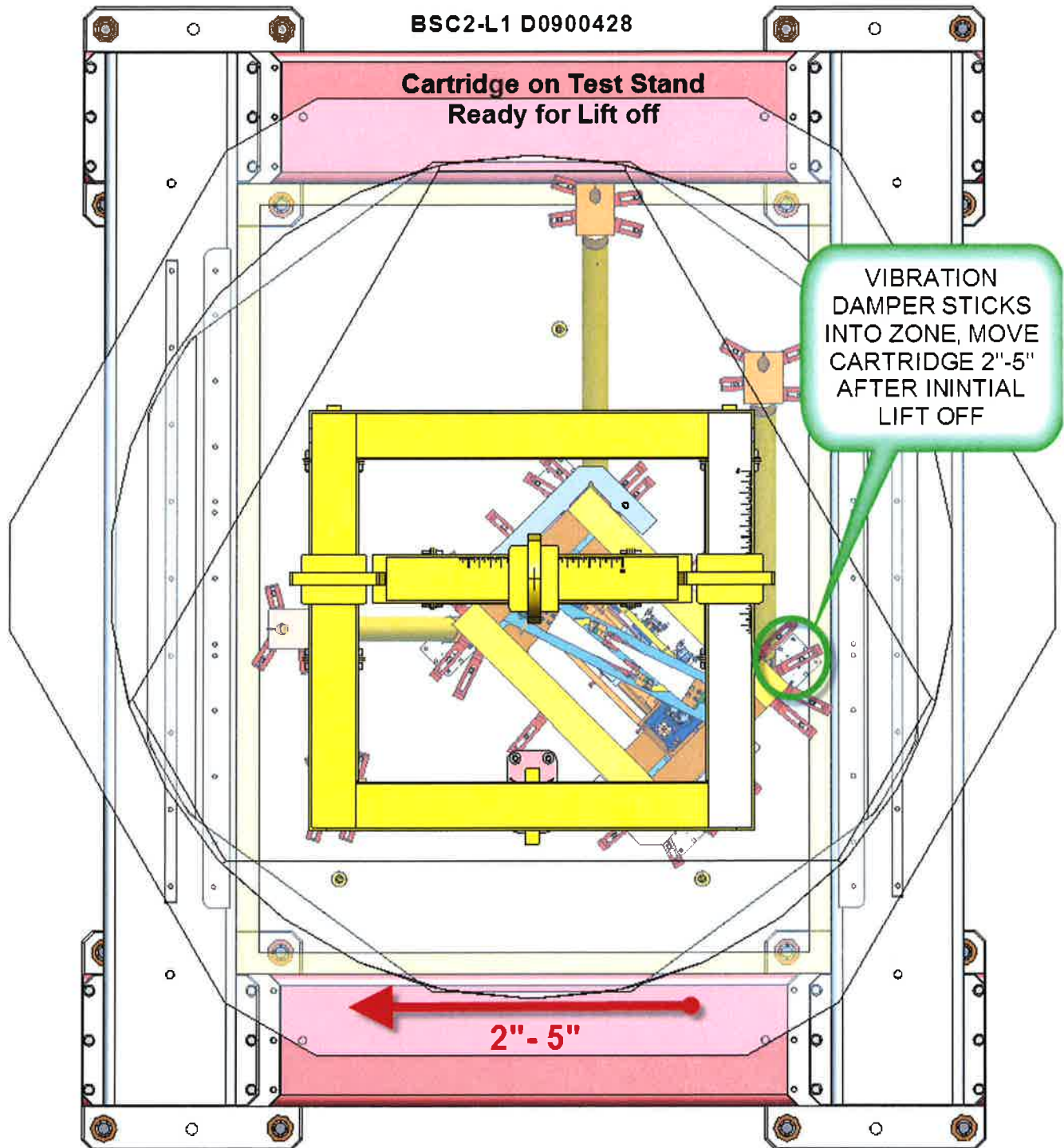

Circles in green indicate any protrusion into the keep out zone. Any global XY moves relative to the Test-Stand will depend on the orientation of the Test-Stand.

BSC2-L1 will need to be rotated 90 deg. before insertion into the camber because the test stand is oriented perpendicular to the support tubes in the BSC chamber.

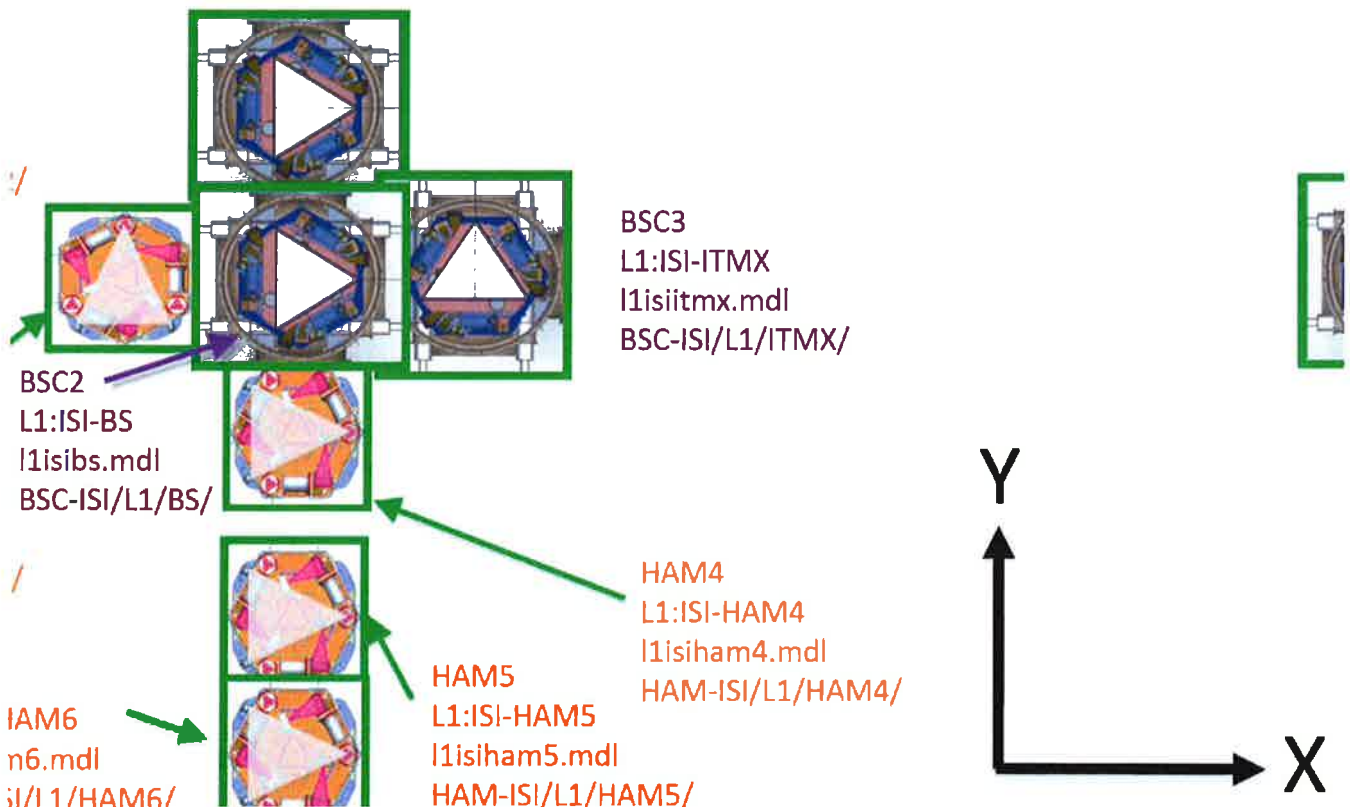
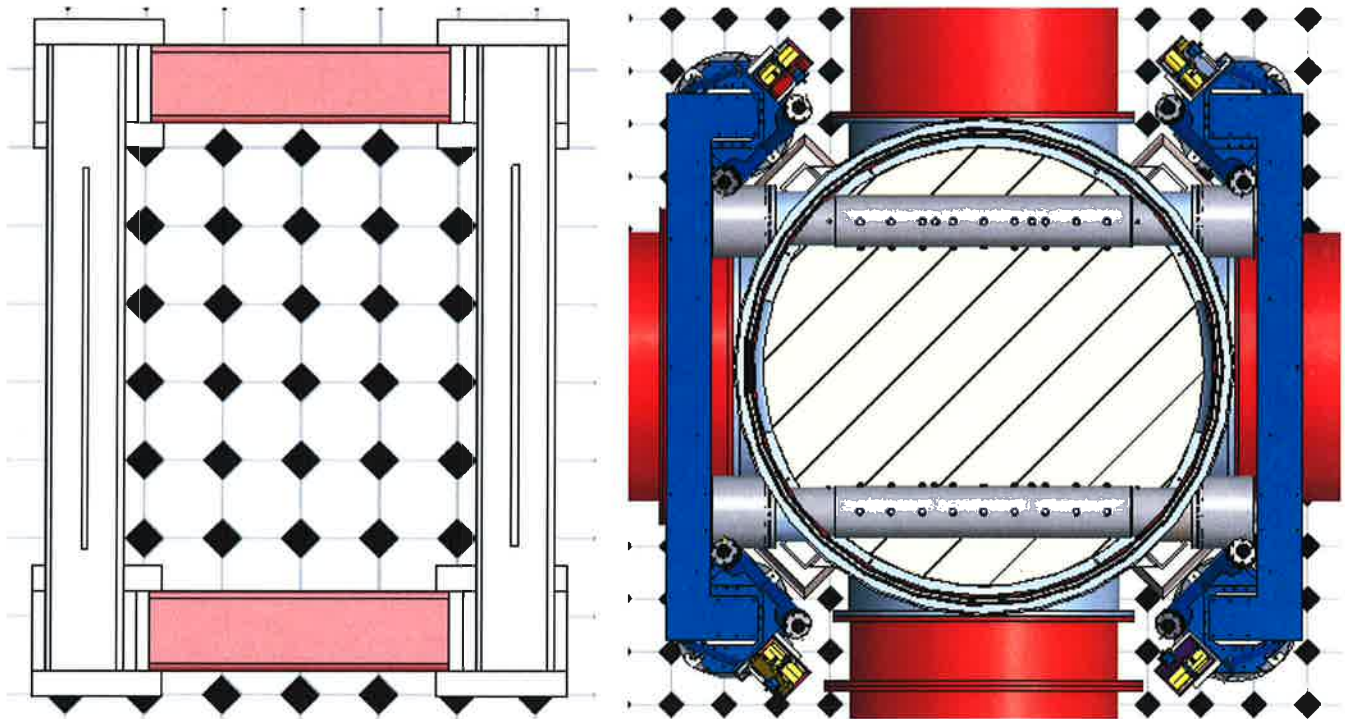

D0900428 BSC2-L1, Crane moves need to clear the Chamber Clearance Zone.

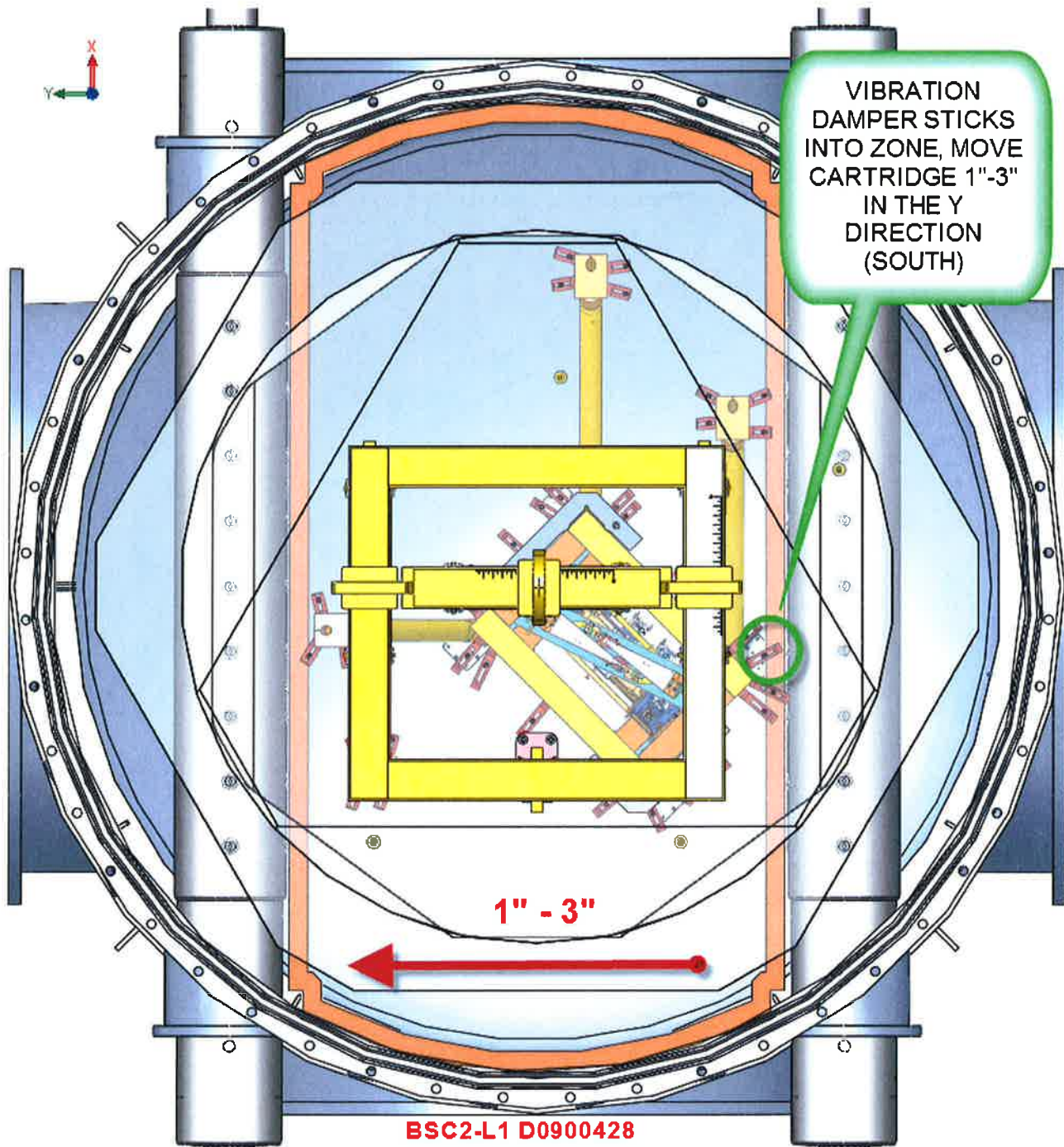

Before insertion a 1"- 3" move in the +Y (South) direction off center line is need. This will allow the vibration damper to clear the beam tubes, and still get ISI stage 0 into the chamber. (+Y is relative to the Global Coord. System as shown in G1000125.)

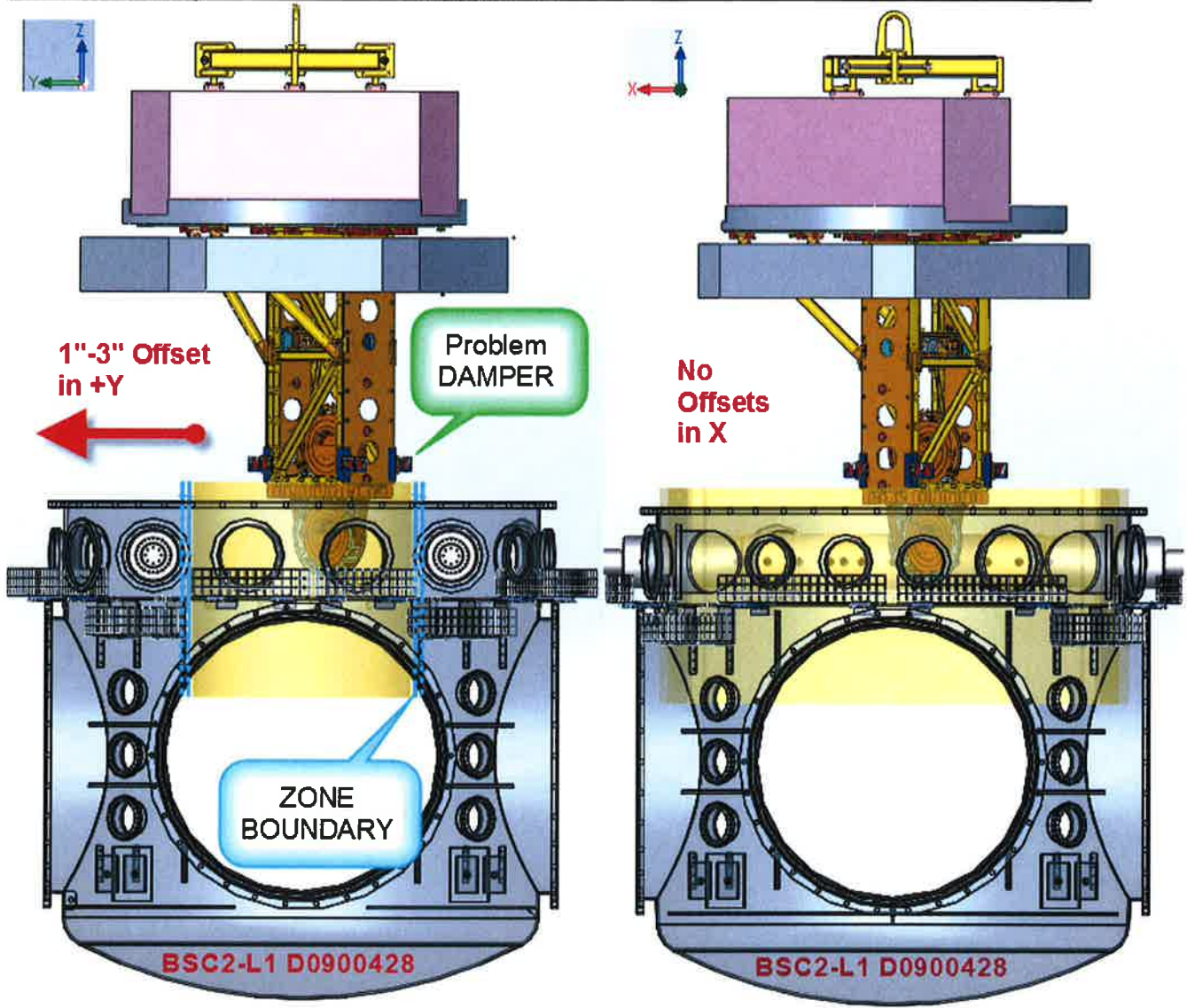

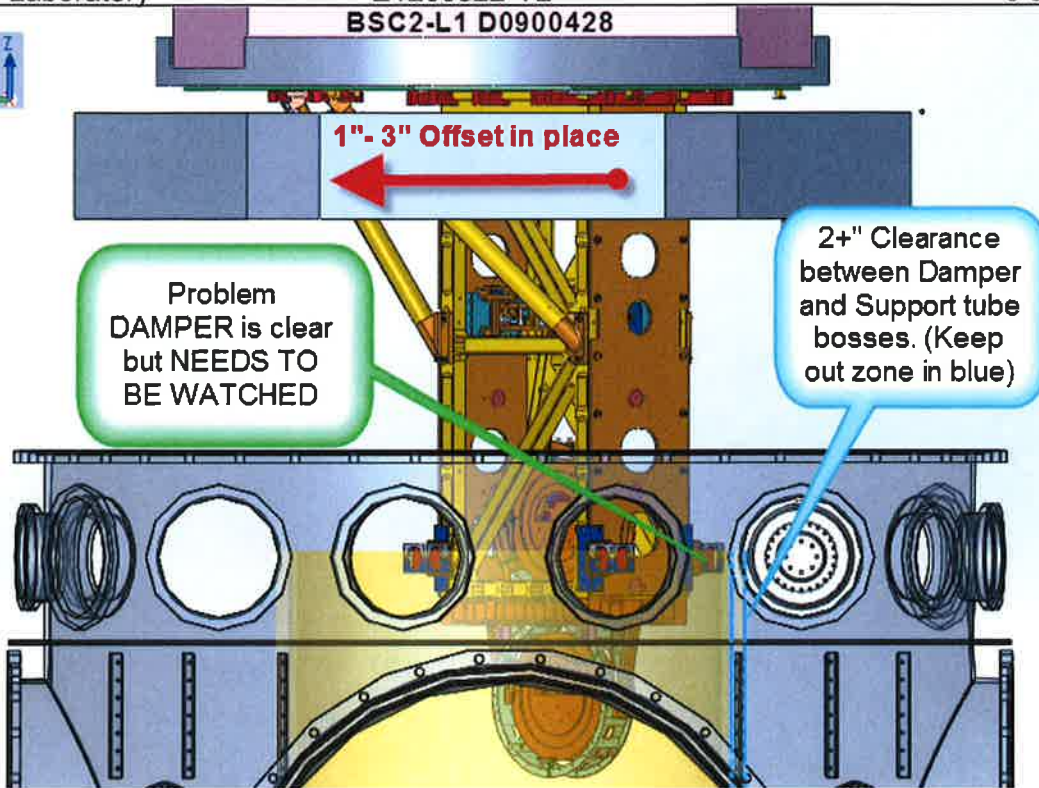

FILE: E1200322

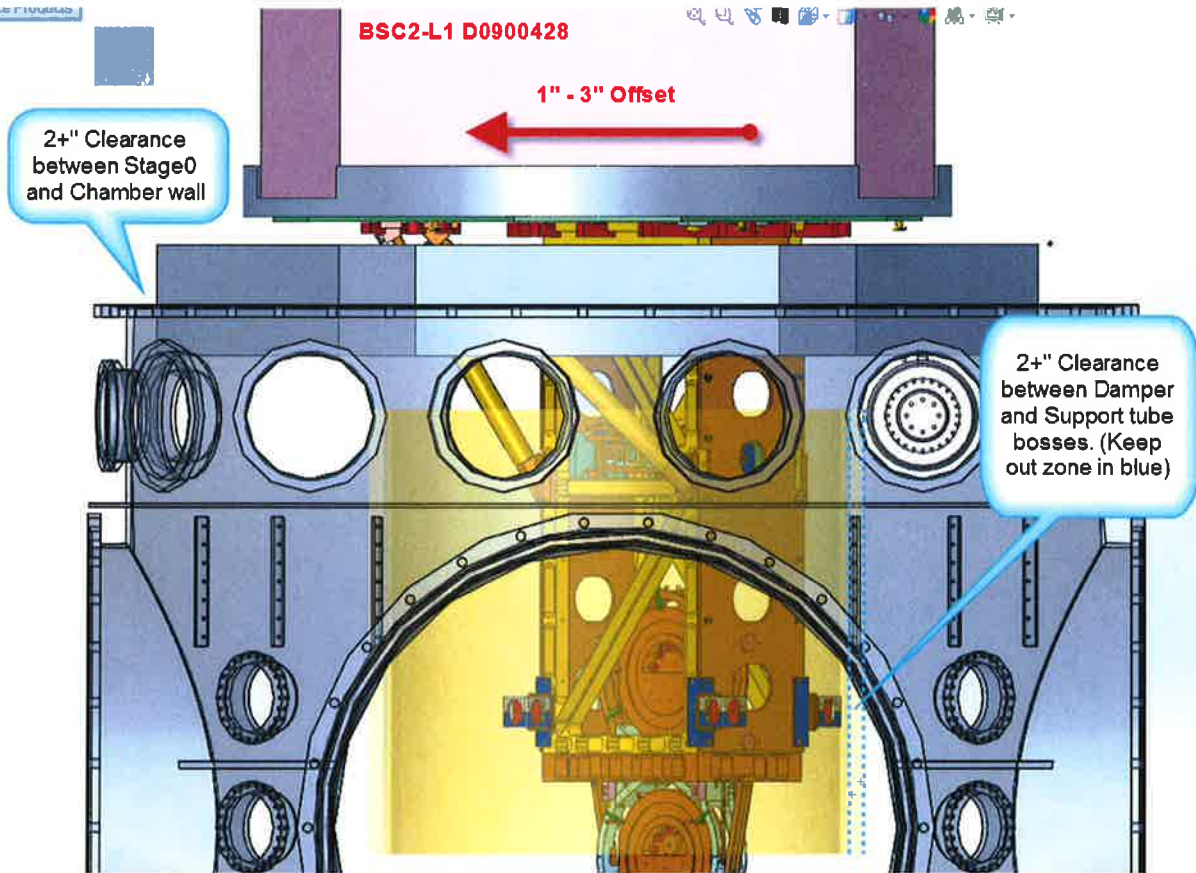

Locating the Bale pre-lift of the cartridge (Some adjustment will be needed)

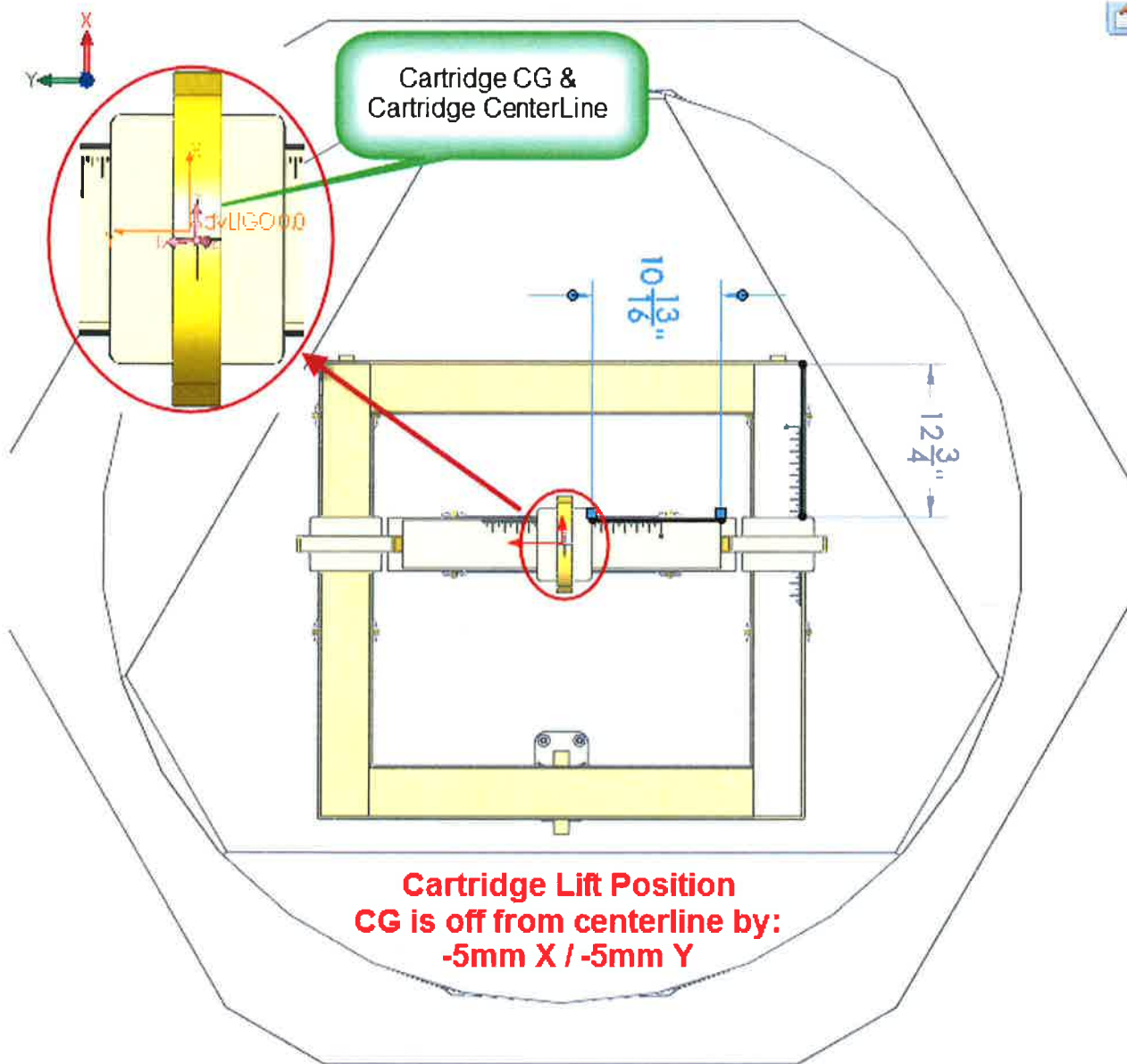

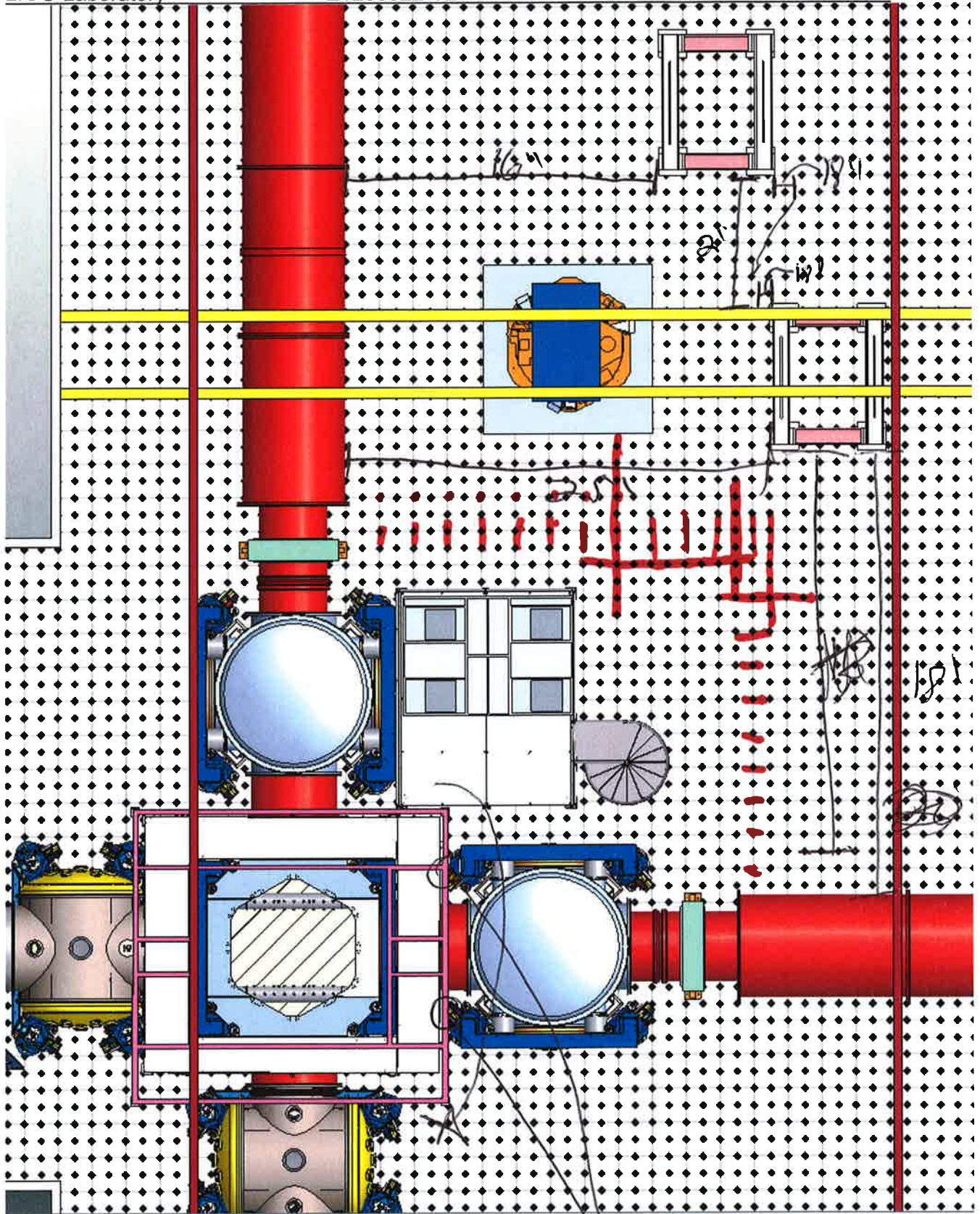

Interference
Page 11 of 12
w/ H-Actuator

Items that will need to be locked down when the cartridge is moved:

1. **BSC-ISI:** (see [E1200344](#) sections 4.2)

completed, approved or checked by:
date:
comments (optional):

2. **BS/FM:** Final checks before moving the BS/FM ([T1100489](#)):

completed, approved or checked by:
date:
comments (optional):

Cartridge: Preparation for, and installation into Chamber:

- aLIGO BSC ISI/Quad Install Procedure: (see [E1101037](#))

completed, approved or checked by:
date:
comments (optional):



LASER INTERFEROMETER GRAVITATIONAL WAVE OBSERVATORY

LIGO Laboratory / LIGO Scientific Collaboration

LIGO- E1200327-v4

Advanced LIGO

11 Jul. 2012

**BSC2-L1 Cartridge Installation
Hazard Analysis**

Sam Barnum, Dennis Coyne, Brian O'Reilly, Norna Robertson, Calum Torrie

Distribution of this document:
LIGO Science Collaboration

This is an internal working note
of the LIGO Project.

California Institute of Technology
LIGO Project -- MS 100-36
1200 E. California Blvd.
Pasadena, CA 91125
Phone (626) 395-2129
Fax (626) 304-9834
E-mail: info@ligo.caltech.edu

Massachusetts Institute of Technology
LIGO Project -- NW22-295
185 Albany St
Cambridge, MA 02139
Phone (617) 253-4824
Fax (617) 253-7014
E-mail: info@ligo.mit.edu

LIGO Hanford Observatory
P.O. Box 1970
Mail Stop S9-02
Richland, WA 99352
Phone (509) 372-8106
Fax (509) 372-8137

LIGO Livingston Observatory
P.O. Box 940
Livingston, LA 70754
Phone (225) 686-3100
Fax (225) 686-7189

<http://www.ligo.caltech.edu/>

APPROVAL SIGNATURES

Dennis Coyne 2012.07.18 10:43:10
-07'00'

Dennis Coyne, LIGO Chief Engineer

Date

David Nolting
2012.07.11 13:56:53 -05'00'

David Nolting, Advanced LIGO Safety Coordinator & LLO Site Safety Responsible

Date

John Worden
Digitally signed by John Worden
DN: cn=John Worden, o=Ligo, ou=LHO,
email=worden_j@ligo.caltech.edu, c=US
Date: 2012.07.18 12:57:21 -07'00'

John Worden, LHO Site Safety Responsible

Date

Matthew Heintze
Digitally signed by Matthew Heintze
DN: cn=Matthew Heintze, o=LIGO Livingston, ou=Caltech,
email=mhentze@ligo-la.caltech.edu, c=US
Date: 2012.07.25 12:52:35 -05'00'

Brian O'Reilly, Advanced LIGO LLO Installation Lead

Date

Michael Landry
Digitally signed by Michael Landry
DN: cn=Michael Landry, o=LIGO Hanford Observatory, ou, email=michael.landry@ligo.org,
c=US
Date: 2012.07.27 10:07:44 -07'00'

Michael Landry, Advanced LIGO LHO Installation Lead

Date

 2012.07.27 13:09:18
-05'00'

David Shoemaker, Advanced LIGO Leader

Date

Digitally signed by Albert Lazzarini
DN: cn=Albert Lazzarini, o, ou,
email=lazz@ligo.caltech.edu,
c=US
Date: 2012.07.27 14:48:37 -08'00'

Albert Lazzarini, LIGO Directorate

Date

CHANGE LOG

Date, version	Summary of Changes
5 Apr 2012	Initial release for comment (modified from E1200253 BSC6)
6 Apr 2012	Removed a number of references to fibers in several sections. Removed doc references to Quad lockdown procedure. Added general Cartridge install doc to references E1200344 Clarified text in section 3.9
28 Jun 2012	Added item for crane hook rotation jam, 2.8 and 5.8 and 6.8 Added item to section 5.1 (no person allowed below a suspended cartridge)
3 Jul 2012	Removed Rusyl Wooley from signatures, Modified David Nolting description to cover.
11 Jul 2012	Add Fall arrest system to 3.8 and 5.6, fix some spelling errors

1) Scope

This document covers safety concerns related to the installation of the BSC2 cartridge from the Test/Assembly stand into the BSC2 Chamber. The cartridge is comprised of the BSC Internal Seismic Isolation (ISI) with all of the optics table payloads which can be lifted and inserted without interference into the chamber.

The scope includes:

- 1) Preparation and liftoff of cartridge from the Test/Assembly Stand.
- 2) Flight of the cartridge from the Test/Assembly stand to the Chamber.
- 3) Insertion of the Cartridge into the chamber.

This document does not cover the issues associated with the individual suspension and seismic systems that are part of the cartridge. Nor does it cover aspects specific to the crane, or handling of optics. These are covered by other documents.

2) Summary of Hazards

The hazards in this work can be broadly divided into the following areas:

- 1) Moving of heavy, delicate and valuable structures with lifting and moving equipment, with potential for shock/impact if dropped or bumped, leading to the following potential failures/hazards:
 - a) Personnel injury (crushing, pinching, falling).
 - b) Damage to equipment, such as:
 - failure/stretching of wires.
 - misalignment of suspension elements.
- 2) Damage to the suspensions or isolation system,
 - a) Impact against the Test/Assembly Stand.
 - b) Impact against the BSC Chamber and Support Tubes.
- 3) Particulate contamination,
- 4) Cartridge dropped,
- 5) Crane failure (without drop) or Power Failure during operation,
- 6) Crane/Structural failure (Overload crane),
- 7) Drop/fall hazard of tools, etc. due to assembly of components at height,
 - a) While putting covers over cartridge.
 - b) During attachment of 3pt Lifter to cartridge.
 - c) When attaching Cartridge to Chamber support tubes
- 8) Crane rotation failure while cartridge suspended ,

3) Overview (Note: all pictures are examples from BSC6, but are applicable to BSC2)

- 3.1 Attach the three (3) Lift Hook Receivers (D1000753) on the ISI Keel-plate, if not already present (See D1000756 for layout and use Bumax-88 3/8"-16 Screws, Torque, 13-15 ft-lb).

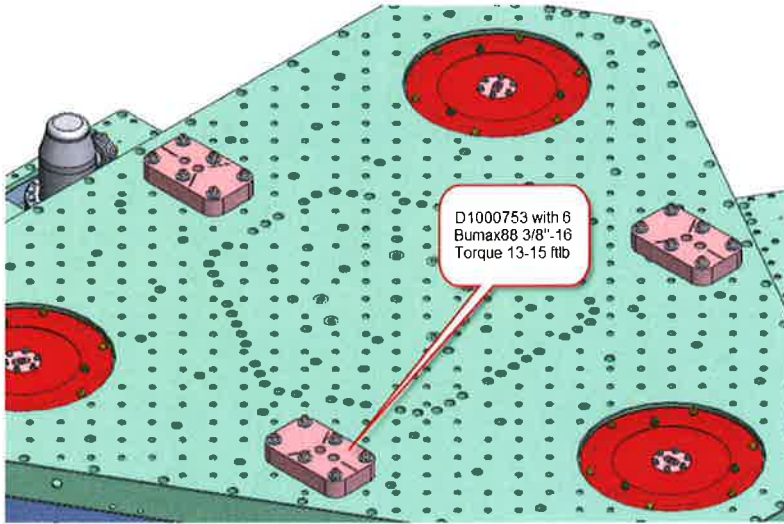

- 3.2 Attach 3pt Lifter to Lift Hook Receivers (D1003140), use 5/8"-11 Grade9, equivalent or better (91271A802, 90201A531), 125-128 ft-lb

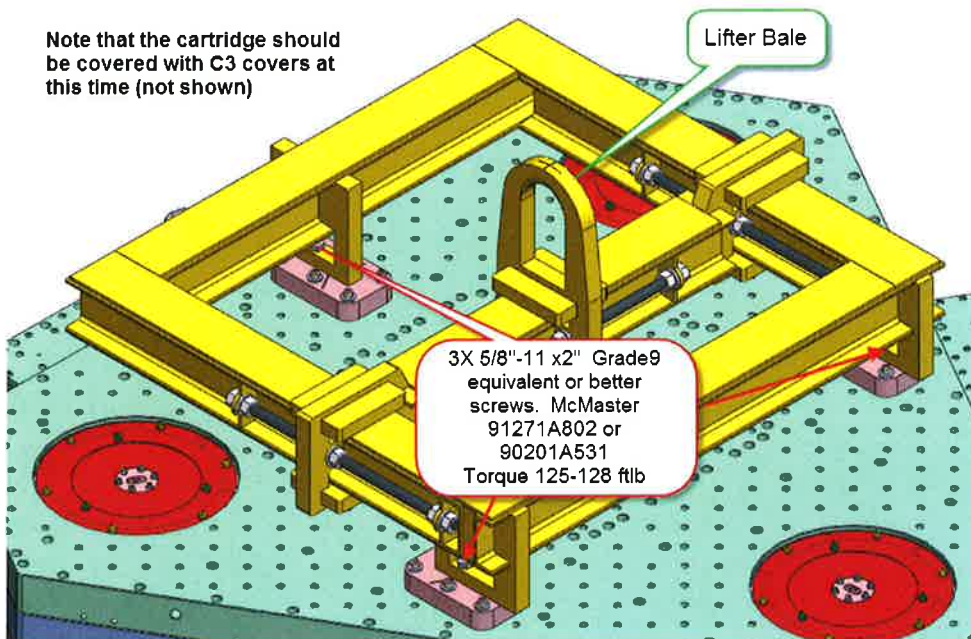

3.3 Crane In position above Cartridge and Test Stand

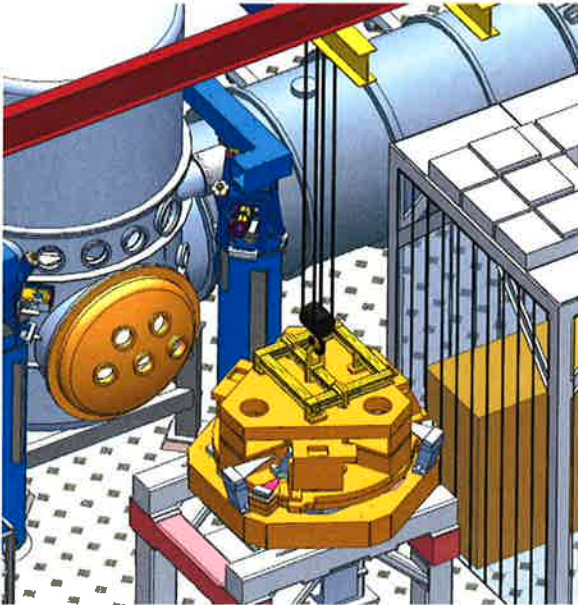

3.4 Adjust 3pt lifter bale (shown below with load cell attached) to predicted X-Y CG location. Then **Check Cartridge weight:** Lift cartridge from test-stand with load cell and crane, If load-cell starts to exceed 10,000lb, stop, and set cartridge back down. Reduce cartridge weight and try again. Record the final total weight, set back down and remove load cell. Record the specific load cell and any needed deviations in the intended payload for the cartridge. If there is a 2" or more gap at any point between the mounting surface of the Test Stand and the mounting surface of the cartridge, the cartridge must be re-leveled. Target gap at any point will be ~ 1/4"



(3pt. Lifter & Load Cell, shown while not attached to cartridge)

3.5 Rotate Cartridge to align with chamber. Insure a protective tarp with clean side up has been placed on the floor in the area where the cartridge rotation will take place (cartridge cover may contact floor otherwise). Attach 2 to 4 taglines to 3pt lifter (to rotate cartridge or serve as backup) Lift cartridge to clear Test Stand and move to designated area over tarp. Lower cartridge to minimum practical height without suspensions contacting the floor. Move staging from around test stand, into place to access stage0 if rotation "by hand" is to be done. Using either taglines or the "by hand" method, rotate cartridge to align with chamber orientation. If pivot on hook becomes jammed, return cartridge to test stand. There is clearance to allow this.

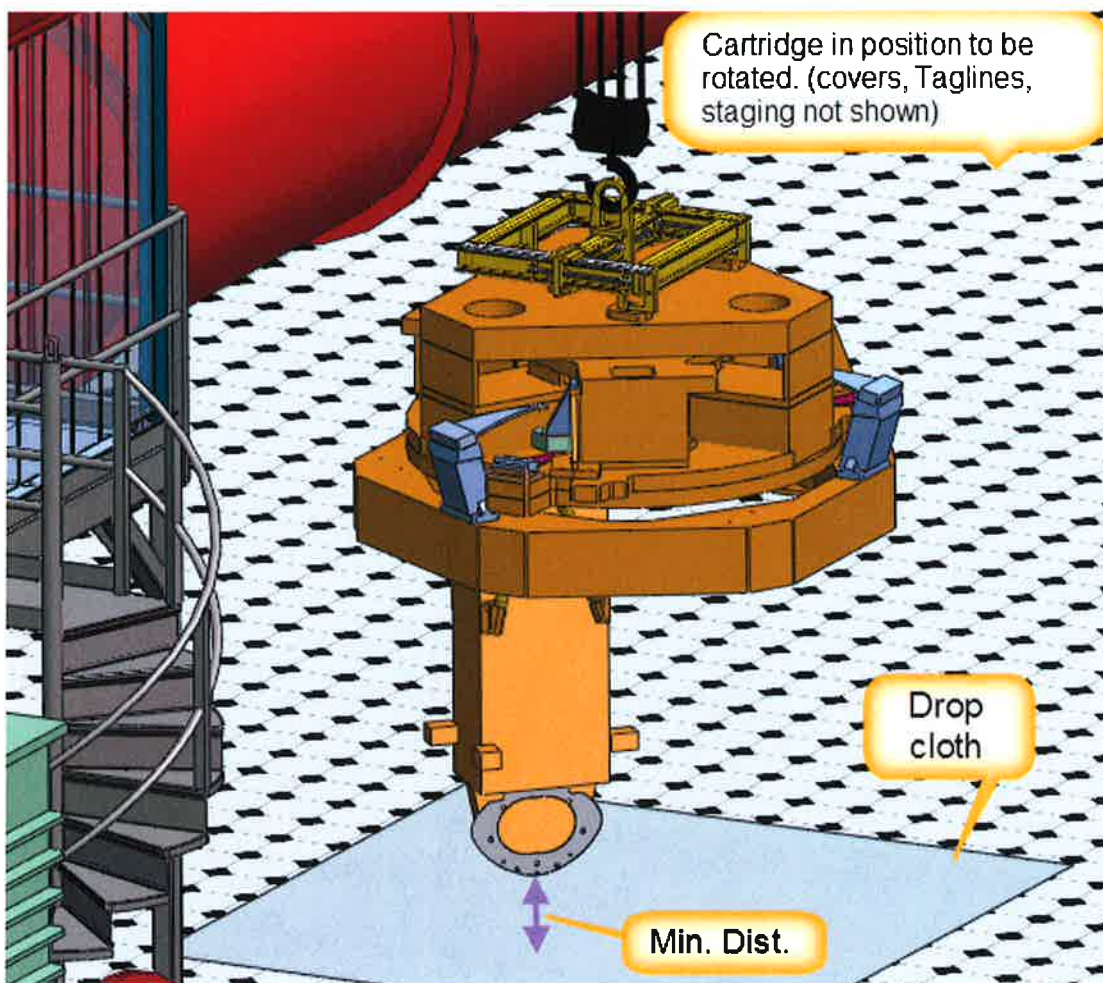

- 3.6 Lift cartridge up to height to clear BSC Clean-room (max height). BSC Clean-room should already be at minimum height (just above spools), Walking Plates (D1002410) and Platforms (D1001990) should be in place without railings, around chambers (See install procedure E1101051). Clean-room clearance ~8"**

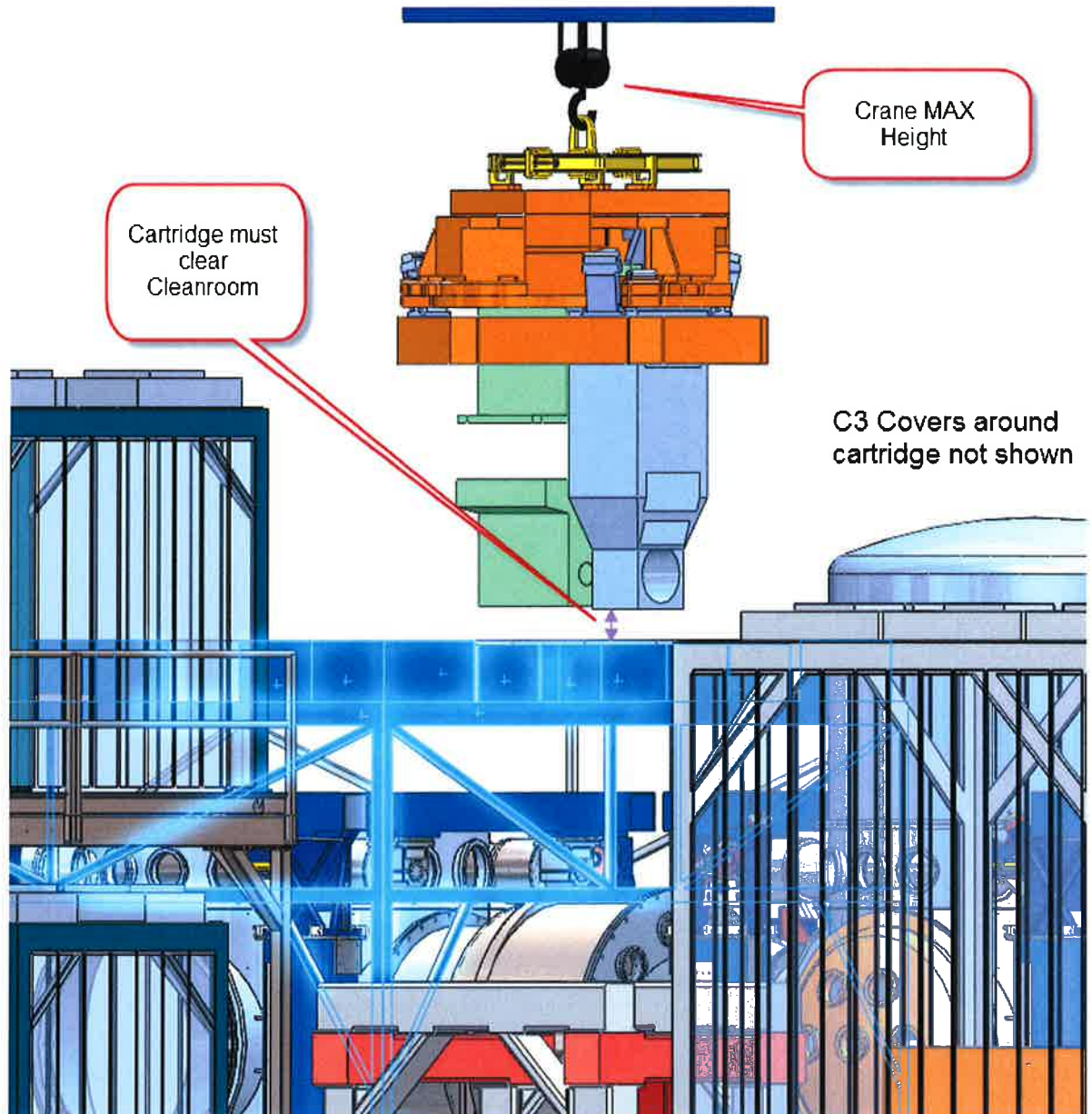

3.7 Move crane to a point centered above target BSC chamber, and BSC Clean-room

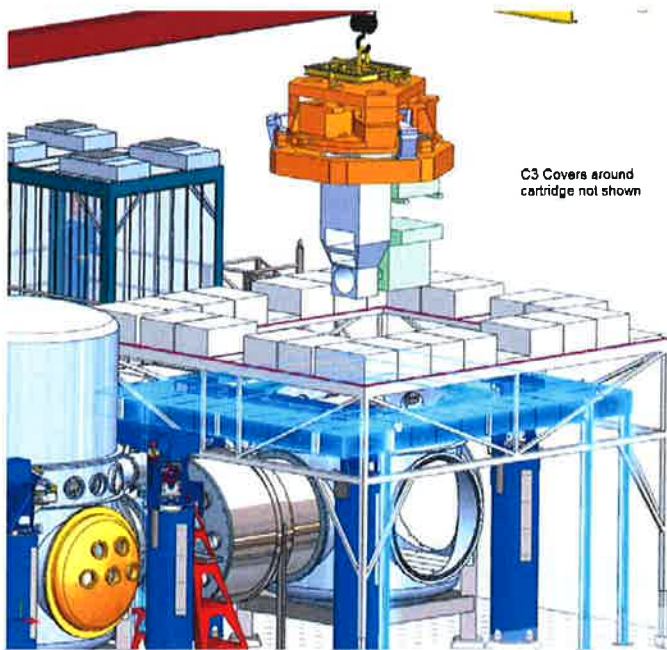

3.8 Raise BSC Clean-room back up to max height, railings will not be installed onto Work Platforms as shown due to lack of clearance. Fall arrest system will be used (personal harness, lanyard, anchor points,) to prevent falls.

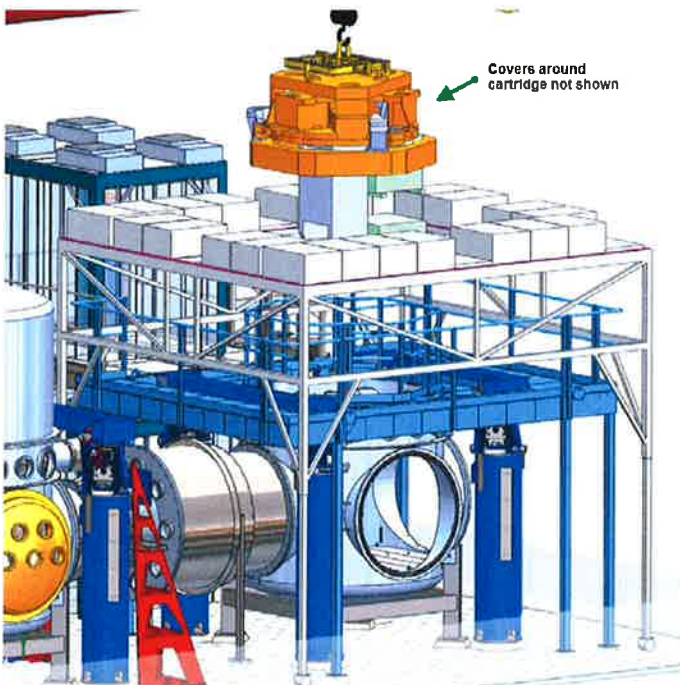

- 3.9 Lower cartridge** to just above chamber, and roll up outside cover to expose stage0, remove fabric cover from chamber. Continue to lower cartridge onto support tubes in chamber.

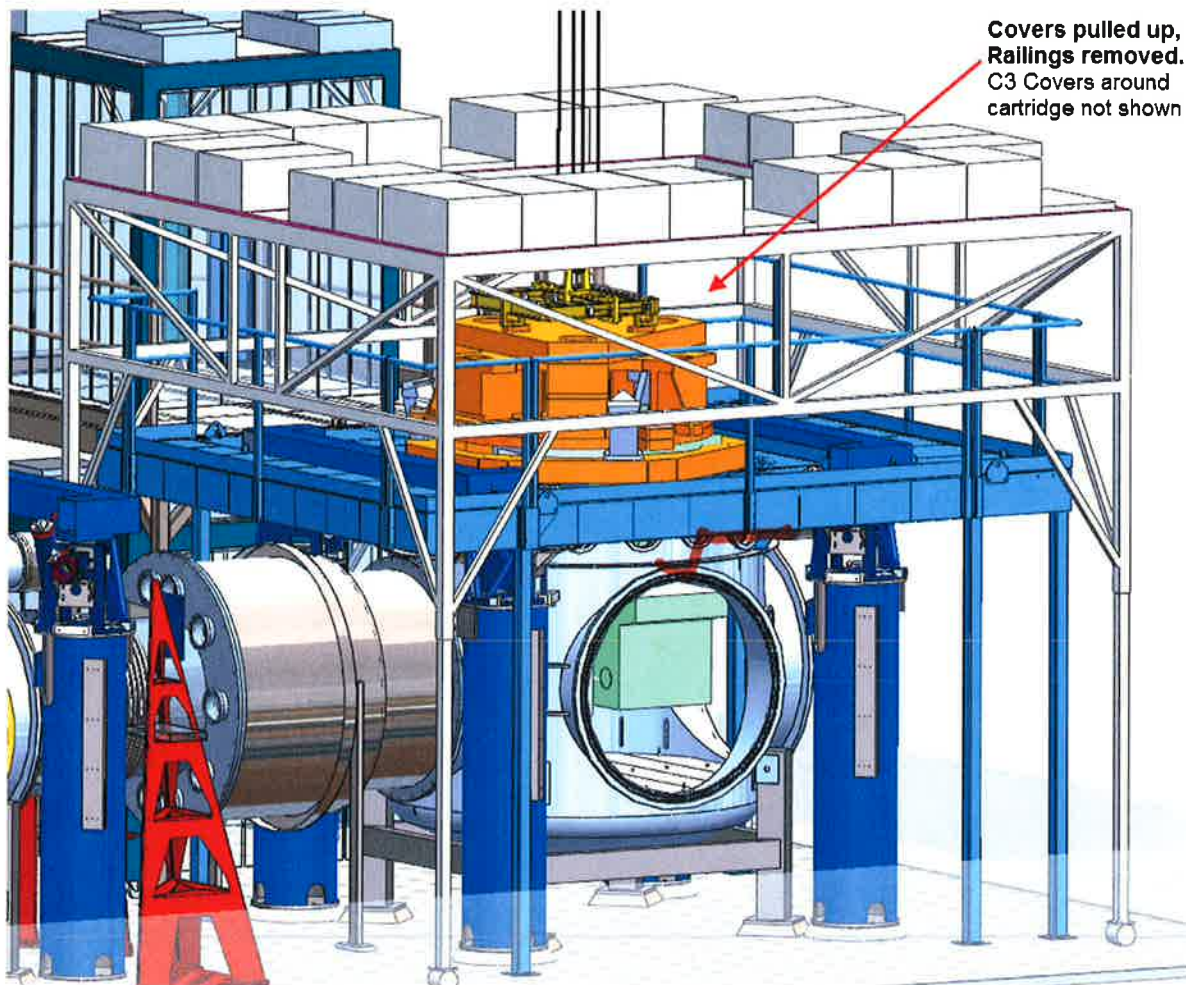

- 3.10 Insert 3/8"-24 x 2" screws** into all 14 holes. Torque 21 ft.lb, Then remove 3pt Lifter, close up clean room, finish removing C3 covers.

4) Related Documents

- [LIGO-E1200329](#): aLIGO Installation Procedure: LBSC2
- [LIGO-E1200322](#): BSC2-L1, Requirements and Procedure, Cartridge Flight and Insertion into BSC Chamber, aLIGO.
- [LIGO-E1101017](#): Cartridge Lifting Hardware, Loading Analysis.
- [LIGO-E1200328](#): Critical lift plan for the aLIGO BSC2-L1 cartridge installation
- [LIGO-T1100489](#): BS/FM installation lock-down Procedure
- [LIGO-E1101051](#): BSC Work Platforms Assembly Instructions
- [LIGO-E1200344](#): BSC Cartridge General Install aLIGO

5) Hazard Analysis

Each hazard, and mitigation approach or measure, is listed in the severity table in the next section

5.1 While moving heavy, delicate and valuable structures using lifting and moving equipment, there is potential for injury, shock and/or impact if structures are dropped or bumped.

- Personnel injury (crushing, pinching, falling)

A minimum number (4) of personnel must be trained for, and follow safety rules of the lifting equipment to be used. Safety glasses, shoes, and hardhats must be worn by personnel involved in the lifting and transporting of the Cartridge. At no time should work be done above head height while people are directly below.
- At no time should any person be beneath a suspended cartridge.
- Damage to equipment (from shifting or vibrations)
- Vibrations, Accelerations and Decelerations during liftoff, transport, and placement have the potential to damage items held in the suspensions or between the stages of the ISI. Therefore the ISI and items in the SUS frames must be locked down per the checklists and references in T1100489 & E1200344.

Damage to the suspensions or isolation system from Impact
- Impact can cause damage directly to the suspension frames, Test Stand, or Chamber. Resulting movement of the suspended items in the frames during an impact can cause secondary damage. Chances of contact with optics table payload is significantly reduced by removing any items that might interfere with the Support Tubes or Chamber. In addition there are lateral moves (laid-out in E1200322 and E1101017) to avoid contact with potentially interfering items. The ISI and items in the SUS frames must be locked down per the checklists and references in T1100489 & E1200344.

5.2 Particulate contamination

- To protect delicate optics and other components, all guards, covers and caps, must be in place. All personnel must be trained and follow the detailed procedure and checklist to ensure all of the required items are in place
- Fabric covers are used over the entire cartridge assembly to catch particulates generated by the crane.

5.3 Cartridge Drop

- Failure of the lifting apparatus causing the cartridge to drop, could result in serious injury and loss of a significant portion of the cartridge hardware. Thus no person will be allowed below the cartridge or within a safety radius of it during liftoff, transport or set-down. Only the crane operator and persons watching for close encounters and/or providing hand signals, shall be allowed in the area where the lift is being made. All others shall stay at a safe distance (20-foot minimum) away from lift activities. The exception to this is in the very early and late stages of liftoff and set-down while the cartridge is only a few inches away from the support tubes, which would shield anyone from the short drop of the cartridge. The cartridge will need to be inspected and guided at these two times. The dropping hazard is mitigated overall by the use of lifting hardware that has a 3 times yield, designed-in, safety factor. It should also be noted that it is recommended that bystanders refrain from talking/making noise that may disturb the concentration and communication of the personnel involved in the lift.

5.4 Failure of crane to operate or power failure during operation

- A failure of the crane lifting mechanism, or power loss during transport will result in the crane locking in place. This is not a safety problem, and covers will prevent contamination. See critical lift plan [LIGO-E1200328](#).

5.5 Structural failure of Crane

- The crane will not be operated beyond rated capacity. All items will be pre weighed, and must only be the ones expected per plans (e.g. E1100322 and E1101017) to be part of the cartridge (no additional unexpected parts).

5.6 Drop/fall hazard due to assembly of components at height

- To prevent falls and dropped items from height, platforms and walking plates with kick panels and railings will be in place as needed around the BSC chamber. Also a Fall Arrest System will be used when railings cannot be used.

5.7 Crane does not allow cartridge to rotate, or jams at partial rotation

- Cartridge can be returned to test stand if hook pivot becomes stuck.



LASER INTERFEROMETER GRAVITATIONAL WAVE OBSERVATORY

6) Hazard Analysis Severity Table (The number in brackets is a reference back to section 2 summarizing the hazard)

Item (Ref)*	Hazard	Cause	Effect	Unmitigated Severity	Unmitigated Probability Level	Unmitigated Risk Index	Comment	Mitigation	Mitigated Severity	Mitigated Probability Level	Mitigated Risk Index
1 (2.1)	Fingers/hand/arm pinching/crushing hazard	Between Cartridge and Support tubes on Test Stand or in Chamber	Injury to personnel	Critical	Occasional	2C		A minimum number (4) of personnel must be trained for and follow safety rules of lifting equipment being used	Negligible	Remote	4D
2 (2.2)	Cartridge impact anywhere other than mounting surfaces.	Interference with support tubes, Test Stand or chambers	Damage to mostly suspended items.	Critical	Probable	2B	Damage concern mostly to suspensions during lift or lower, to stand or chamber	Remove interfering items & lateral moves of cartridge to clear obstacles.	Marginal	Remote	3D
3 (2.3)	Particulate contamination	Debris falling from above: crane etc. Removal of protective covers/caps	damage to environment	Marginal	Probable	3B		C4 Cloth covers for cartridge and suspended components	Marginal	Remote	3D
4 (2.4)	Payload drop hazard	Improper use of interface tooling, linkages, crane	Injury to personnel; damage to equipment	Critical	Remote	2D	3X or better safety factor on all lifting equipment and hardware (Industry standard)	Personnel must be trained and follow detailed procedure and checklist.	Critical	Improbable	2E
5 (2.5)	Failure of lifting mechanism, power outage	Lifting equipment not serviced or used as per instructions, power outage	Nuisance, lost time	Marginal	Remote	3D	Final weight of cartridge measured, insure crane within operating spec. at all times. Chamber covers if need	lifting equipment should be inspected and maintained, so that a failure is unlikely. Do not operate at time when a power outage is likely. Make sure cartridge config. is as expected	Negligible	Improbable	4E
6 (2.6)	Crane, structural failure	Overloaded crane, poor crane related maintenance	Injury to personnel; damage to equipment	Critical	Remote	2D		All items to be lifted pre weighed, Test lift, Proper crane maintenance	Critical	Improbable	2E
7 (2.7)	Assembly of components at height	On top of, or below Cartridge and above Support tubes	Injury to personnel; damage to equipment	Critical	Remote	2D	-	Use barrier plates and railings as instructed, and personnel must wear safety glasses ,shoes ,hard hats	Critical	Improbable	2E
8 (2.8)	Crane rotation failure	Hook Binds	Wrong orientation	Marginal	Remote	3D		Return cartridge to test stand, repair crane	Negligible	Improbable	4E

7) Key

Key to table in section 6

Severity	Category	Definition
Catastrophic	1	Death or permanent total disability, system loss, major property damage or severe environmental damage
Critical	2	Severe injury, severe occupational illness, major system or environmental damage
Marginal	3	Minor injury, lost workday accident, minor occupational illness, or minor system or environmental damage
Minor	4	Less than minor injury, first aid or minor supportive medical treatment type of occupational illness, or less than minor system or environmental damage.

Probability	Level	Definition
Frequent	A	Likely to occur frequently or continuously experienced
Probable	B	Will occur several times in the life of an item
Occasional	C	Likely to occur some time in the life of an item
Remote	D	Unlikely but possible to occur in the life of an item
Improbable	E	So unlikely, it can be assumed occurrence may not be experienced.

PROBABILITY

SEVERITY OF CONSEQUENCE	E Improbable	D Remote	C Occasional	B Probable	A Frequent
1 Catastrophic	Light Green	Orange	Red	Red	Red
2 Critical	Light Green	Orange	Red	Red	Red
3 Marginal	Light Green	Light Green	Orange	Red	Red
4 Negligible	Teal	Teal	Teal	Light Green	Light Green
Hazard Risk Index	Risk Code Criteria				
1A, 1B, 1C, 2A, 2B, 3A	Unacceptable				
1D, 2C, 2D, 3B, 3C	Undesirable (Directorate decision required)				
1E, 2E, 3D, 3E, 4A, 4B	Acceptable with review by Directorate				
4C, 4D, 4E	Acceptable without review				

D0900512-v3, BSC6-H2 Top Level Chamber Assembly

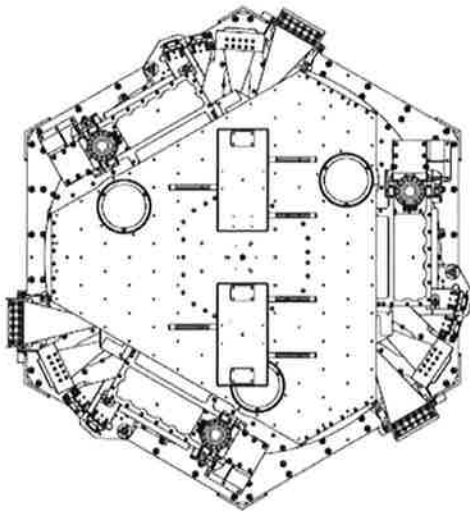

TOP VIEW

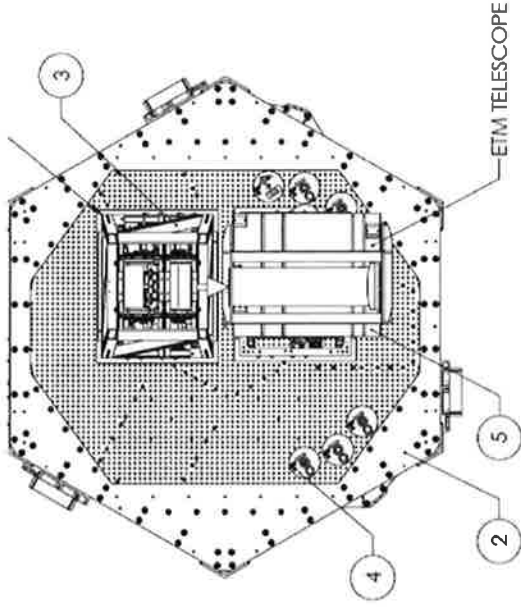

BOTTOM VIEW

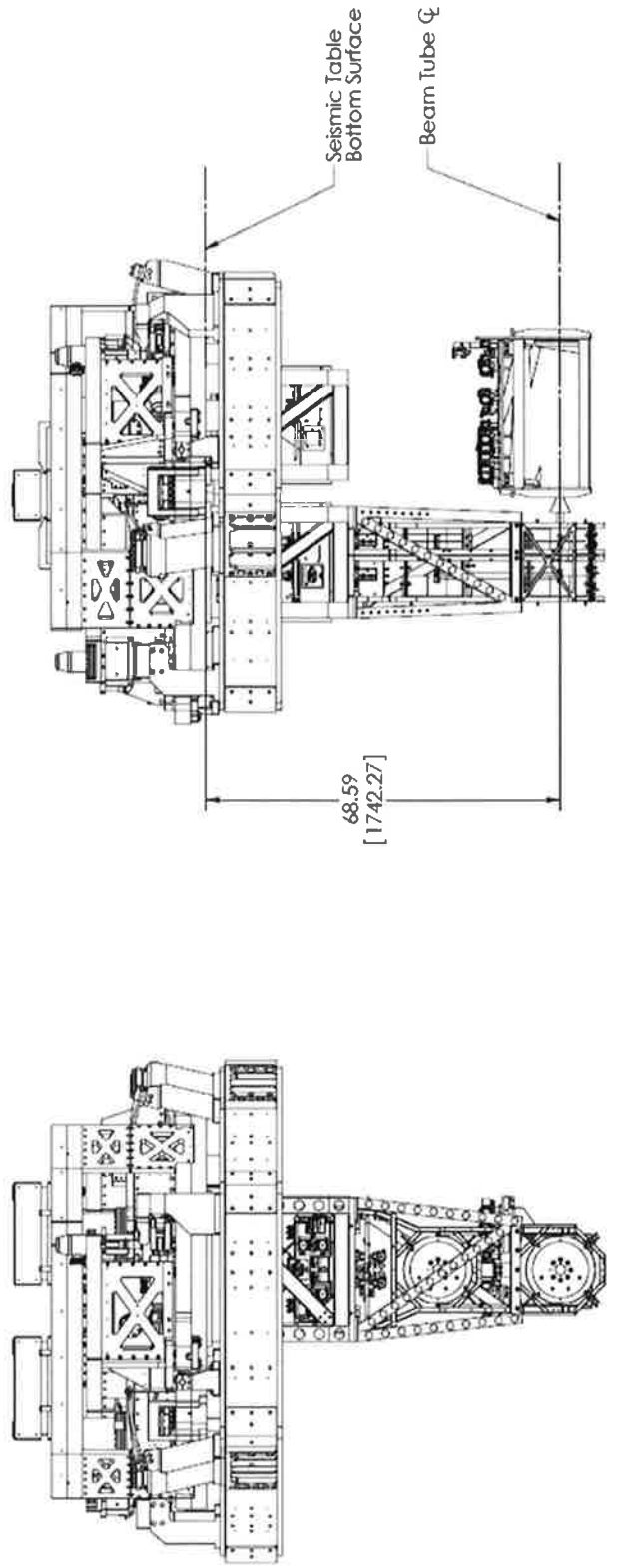

BSC-ISI mechanical test stand
assembly: D080464-v3
78 inches x 96 inches

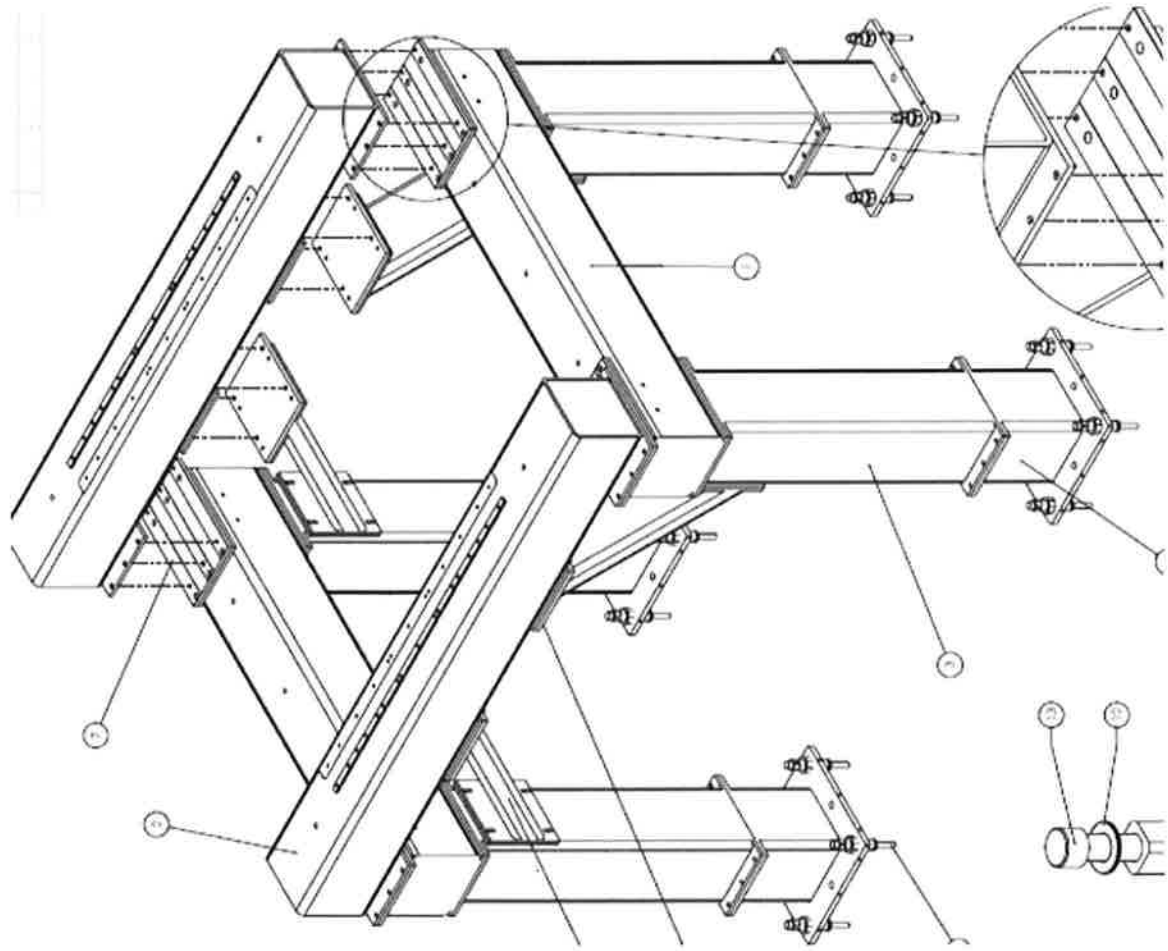

4

NOTES CONTINUED:

- ⑤ SCRIBE, ENGRAVE, OR MECHANICALLY STAMP (NO INKS OR DYES) DRAWING PART NUMBER, REVISION (AND VARIANT OR TYPE IF APPLICABLE) ON NOTED SURFACE OF PART FOLLOWED ON THE NEXT LINE WITH A THREE DIGIT SERIAL NUMBER. SERIAL NUMBERS START AT 001 FOR THE FIRST ARTICLE AND PROCEED CONSECUTIVELY. USE MINIMUM 0.12" HIGH CHARACTERS. UNLESS THE SIZE OF THE PART DICTATES SMALLER CHARACTERS. (MINIMUM FONT SIZE MAY BE USED)
- EXAMPLE: DXXXXXX-V1, TYPE-XX, S/N XXX

D

3

2

1

REV.	DATE	DCN #	DRAWING TREE #
-	-	-	-
-	-	-	-
-	-	-	-

D



5/32 THRU

C

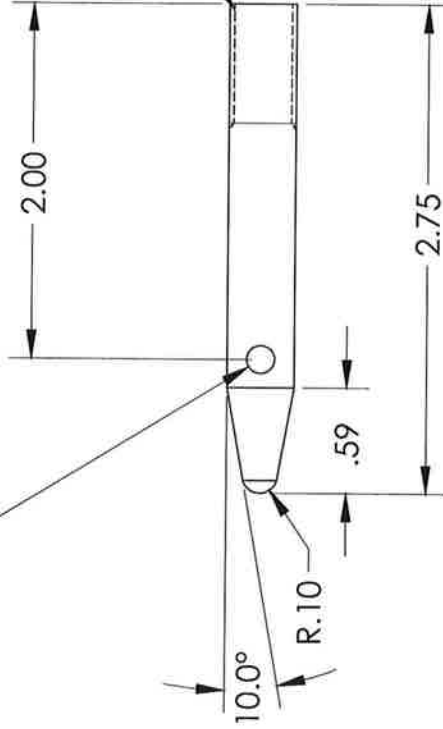

B

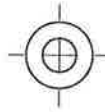

B

A

DIMENSIONS ARE IN TOLERANCES:

- XX ±
- .XX ±
- .XXX ±
- ANGULAR: °

NOTES AND TOLERANCES: (UNLESS OTHERWISE SPECIFIED)

- 1. INTERPRET DRAWING PER ASME Y14.5-1994.
- 2. REMOVE ALL SHARP EDGES, R1/2 MIN.
- 3. DO NOT SCALE FROM DRAWING.
- 4. ALL MACHINING FLUIDS MUST BE FULLY SYNTHETIC, FULLY WATER SOLUBLE AND FREE OF SULFUR, SILICONE, AND CHLORINE.

MATERIAL 6061-T6 (SS)

FINISH

pinch

3

SYSTEM NEXT ASSY

LIGO CALIFORNIA INSTITUTE OF TECHNOLOGY MASSACHUSETTS INSTITUTE OF TECHNOLOGY

ADVANCED LIGO SEI

DESIGNER DRAFTER CHECKER APPROVAL

2

PART NAME

Cartridge Install Alignment Pin

11/02/2011 SIZE DWG. NO.

A D1102282

REV.

SCALE: 1:2 PROJECTION: 1

SHEET 1 OF 1

Cartridge Install Alignment Pin, PART PDM REV: v1, DRAWING PDM REV:

LBSC2 Install Tasks and Teams

Meeting participants: Gary, Jeremy, Matt H., Celine, Janeen

Meeting date: Monday, 20 August 2012

BSC2 Preparation

A. Support tube positions (~~2~~ only)

~~1. Move, if needed~~

B. Clean room in place

~~1. Attach legs~~

~~2. Attach lifting fixture~~

~~3. Test range of legs~~

C. Platform erection

~~1. "E" module~~

~~2. Staircase & cleanroom on "E" module~~

~~3. Transition plate and rails. Safety approval~~

~~4. "S" bars~~

~~5. Walking plates & handrails (check for clean)~~

~~D. Remove 90% of dome bolts~~

① Particle counts *Jeremy*

~~2. Set up dome laydown~~

~~3. Remove dome~~

~~4. Refer to point C5~~

~~5. Lower cleanroom~~

Wed
○ Change wire down
○ Move Filter + Light
○ Load test in Am
Done after noon
○ Walk Platg
stage Garb
support tube)
Thurs
Done for LSC3
Meeting
Friday install

BSC3 Preparation

~~A. Crane engine hoist~~

~~B. Crane cleanroom~~

~~C. Place cleanroom~~

~~1. Plastic sheeting~~

2. Plug up & run for 24 hours *started 1200 Tuesday*

~~D. Remove 90% bolts or remove~~

~~E. Check particles~~

Cartridge Preparation

~~A. Align baffles~~

~~B. B&K hammering~~

~~C. Lock BS and ISI (in order)~~

~~D. Unload dummy masses~~

~~E. Unhook & secure vacuum cables~~

~~F. Cover BS~~

~~G. Install lift plates~~

~~H. Remove bolts from test stand~~

~~I. Test lift and weigh verification, remove rigging~~

~~J. Install dial indicators~~

Cartridge Install

A. Install lift fixture

B. Attach to ISI and lift

C. Refer to procedure

Install Teams

Crane: Harry, Joe, Gary

BACKUPS

Install Lead: Jeremy, Matt

Cleanroom up/down:

MARC/APOLLO
controller = ~~Chris/Excel~~, BEVAN
4 legs = 2 Excel & ~~Celine~~ | Mike P. backup
Jeany

Red ink BSC2
Black ink BSC1

Rec-Lift: Adrien, Joe H, Mike P, Celine

Top spotters: Danny, Joe, Mike ✓

In-chamber: Adrien, Gary, ~~Jeany~~ (Celine outside)
Mike P.

Tag lines - ~~Jeany~~ Mike P APPOLLO
BRYAN

BSC 2 Install

Install Team and Assignments

Install Lead:

- Primary:- **Jeremy**,
- Back-up:- ~~Matt~~, **Gary T**

Crane:

- Primary:- **Harry**,
- Back-ups: **Joe H**, **Gary T**

Preparing cartridge for lift:

- SUS:- **Gary T** / **Danny**
- SEI:- **Adrien**, **Joe H**, **Mike V**, **Celine**, **Mike P**

On Tag lines when cartridge moves:

- **Jimmy**, **Mike P**, **Danny**

Moving cleanroom up and down:

- Controller:- **Chris/Excel**
- 4 legs:- **2 Excel & Celine**, **Jeremy** / **Mike P** / **Brian**

Top spotters on top of chamber (+Removing fixture):

- **Danny**, **Joe H**, **Mike V**.

In-chamber:

- Clean personnel:- **Adrien**, **Gary**, **Jimmy**
 - Back-up:- **Mike P**
- "Dirty" person:- **Celine**

Floating personnel:

- **Mike M**, **Jeremy**, ~~Matt H~~

Safety:

- **Anna H**

Pictures:

- Primary:- **Bobby**
- Secondary:- ~~Matt H~~

