

Kit L SERIES

Optical Linear Encoder with Online Compensation

USER MANUAL

Index

1.	Features and Applications	5
2.	Safety	6
2.1	General Information	6
2.2	Notes on Legal Requirements	7
2.3.	Notes on Transport, Storage and Handling	8
2.4.	Notes on Operation	9
2.5.	Notes on Maintenance	9
3.	Setup of the Rotary Kit Encoder	10
3.1	Setup with Signal Processing in a D-Sub Connector	10
3.2	Setup with Signal Processing on a Connector PCB	10
3.3	Setup without Signal Processing	11
3.4	Features Kit L2	12
3.5	Features Kit L4	12
4.	SINGLEFLEX Scale Tape	13
4.1	Setup SINGLEFLEX MV	13
4.2	Setup SINGLEFLEX MT	13
5.	DOUBLEFLEX Scale Tape	14
5.1	Setup DOUBLEFLEX MV	14
5.2	Setup DOUBLEFLEX MT	14
6.	Technical Data	15
6.1	Resolution and Accuracy (Definition)	15
6.2	Mechanical Data	16
6.3	Electrical Data	17
6.4	Switch-On Behaviour	17
6.5	Attainable Traversing Speed	18
6.6	Ambient Conditions	19
6.7	Cable	19
6.8	Connector PCB	20
6.8.1	Type 1 with Signal Processing	20
6.8.2	Type 2 with Signal Processing	20
6.8.3	Type 2 without Signal Processing	21
6.9	Dimensions Connector Cable with Open Output	21
6.10	Connector Variants	22
6.11	PIN Assignment	23
6.12	PIN Assignment for Connector PCB X ₁	24

6.13	PIN Assignment for JST Miniature Connector X_2 and X_3	24
6.14	Electromagnetic Compatibility (EMC)	25
6.15	Shielding Concepts	26
6.16	Voltage Output $1 V_{PP}$	27
6.17	Square-Wave Output RS 422	28
6.18	Online Compensation (Offset and Amplitude Control)	29
7.	General Installation Notes	30
7.1	Delivery Contents	30
7.2	Installation Position	30
7.3	Mounting Steps	31
8.	Signal Adjustment with ADJUSTMENT TOOL	38
8.1	Functions of the ADJUSTMENT TOOL	38
8.2	Dynamic Offset and Amplitude Control (Online Compensation)	38
8.3	Scope of Delivery	38
8.4	EPIFLEX Software	39
9.	Mounting Drawing - Kit L2	40
9.1	Scanning Head Kit L2	40
9.2	Assignment of Scanning Head, Scale Tape and Measuring Length	41
9.3	Contour for Sensor Frame	42
9.4	Permissible Position Deviations - Coordinates	42
9.5	Sensor Frames - Examples	43
9.5.1	Frame B1 / B2	43
9.5.2	Frame L2 / L3	43
9.5.3	Frame P4	43
10.	Mounting Drawing - Kit L4	44
10.1	Scanning Head Kit L4	44
10.2	Assignment of Scanning Head, Scale Tape and Measuring Length	45
10.3	Contour for Sensor Frame	46
10.4	Permissible Position Deviations - Coordinates	46
10.5	Sensor Frames - Examples	47
10.5.1	Frame B1 / B2 / B3 / B4	47
10.5.2	Frame C1 / C2	47
10.5.3	Frame C6	47
11.	Cleaning	48
12.	Troubleshooting	49

13.	Ordering Key	50
13.1	Scanning Head Kit L2	50
13.2	Scanning Head Kit L4	51
13.3	Speed Chart for LIK Series	52
13.3.1	LIK Series with Op-Amp	52
13.3.2	LIK Series without Op-Amp	54
13.4	Scale Tape MV	56
13.5	Scale Tape MT	57
13.6	ADJUSTMENT TOOL	58

1. Features and Applications

Position encoders in drive systems have to meet high and controversial demands, especially in linear drive systems. The demands opposing each other are high accuracy and resolution on the one hand and low mass, small dimensions and high measuring speed on the other hand.

- The graduated scale is definitive for the quality of a linear encoder. Requirements for maximum position deviations of $\pm 2 \mu\text{m}$ per meter or less are no rarity. The emphasis is mostly on the avoidance of shortrange errors, since long-range errors, mostly linear error components, can often be compensated.
- The concentration of multiple axes in motion in very tight spaces, such as in semiconductor-producing machines, requires the miniaturization of the drives, guideways and encoders.
- High machining speeds and therefore high accelerations make low masses of the components in motion essential.

The Kit L incremental encoders from NUMERIK JENA are equipped with features which are supposed to fulfill these high requirements in an ideal way.

- Due to an interpolation circuitry which is integrated in a 15-pin D-sub connector, a resolutions down to 50 nm is possible without any additional electronics.
- The permissible traversing speed for a sinusoidal signal output amounts to 10 m/s. A Square wave signal output with a resolution of $0.1 \mu\text{m}$ allows a permissible traversing speed of 1.6 m/s.
- The short-range position errors (interpolation errors) were significantly reduced by introducing an electronic compensation of amplitude and offset deviations of the coarse signals. This compensation functions without following error in all velocity ranges.
- The Kit encoder series was especially developed for customized applications and offers a large variety of configuration possibilities.

Additional features:

- Compact size and ultra flat design
- Customizable sensor frames and housings available
- Reference signal(s) with repeatability accurate to a specific increment, regardless of the direction from which the reference mark(s) is/are traversed
- Special, easy to mount scale tapes (SINGLEFLEX and DOUBLEFLEX) for a variety of applications and ambient conditions
- Possibility of electronic signal adjustment (signal optimization after mounting)

Applications:

- Production and inspection machines for the semiconductor industry
- Linear units, drives and coordinate tables
- Measuring machines and measuring microscopes
- Positioning and measuring devices for medical technology
- Precision devices for reprography
- Precision machining
- Robotics

2. Safety

2.1 General Information

- Make sure to familiarize yourself thoroughly with the contents of these installation instructions before installing and starting up the encoder!
- Please contact the support of NUMERIK JENA GmbH or an authorized representation for further information. Please visit the NUMERIK JENA website to get the contact information.
- NUMERIK JENA GmbH is not liable for damages caused by unauthorized handling of the encoders. Any unauthorized handling leads to forfeiture of all warranty claims.
- The encoders are guaranteed to function if the mounting and operating conditions are maintained as stated in these mounting instructions.
- Make sure to follow the right sequence of the mounting steps during mounting.
- NUMERIK JENA GmbH does not assume any liability for any damages or operating errors caused by incorrect installation or operation.
- The stated tolerances must be maintained in order to achieve the accuracies listed in the specifications!
- If the machine tolerances exceed the tolerances stated in the mounting instructions, errors can occur in both the operation and during measuring. NUMERIK JENA GmbH assumes no liability for this.
- Please refer to the operating manuals and safety instructions included with the devices to ensure the reliable operation of the encoder systems, especially pertaining to:
 - Auxiliary electronic units
 - Counters
 - Displays
 - Controllers
 - Encoders
 - Base mechanical devices (machine tools)
- Please pay attention to the safety instructions and warning symbols!



Danger to the device or to the function of the device!



Pull the plug!



Highly inflammable!

2.2 Notes on Legal Requirements

- The NUMERIK JENA encoders conform to EC standards and carry the CE mark.
- NUMERIK JENA encoders fulfill the requirements of the (German) Product Safety Act (ProdSG) from November 8th, 2011.
- Connect NUMERIK JENA encoders only to subsequent electronics whose power supply is generated from PELV systems (EN 50178).
- NUMERIK JENA encoders fulfill the requirements of standard IEC 61010-1 only if the power is supplied from a secondary circuit with current limitation as per IEC 61010^{3rd Ed.}, Section 9.4 or with power limitation as per IEC 60950-1^{2nd Ed.}, Section 2.5 or from a Class 2 secondary circuit as specified in UL1310.*
- This user manual supersedes all previous editions, which thereby become invalid. The basis for ordering from NUMERIK JENA is always the user manual edition valid when the contract is made.
- Standards (ISO, EN, etc.) apply only where explicitly stated in the user manual.

* In place of IEC 61010-1^{3rd Ed.}, Section 9.4, the corresponding sections of standards DIN EN 61010-1, EN61010-1, UL 61010-1 and CAN/CSA-C22.2 No. 61010-1 can be applied and in place of IEC 60950-1^{2nd Ed.}, Section 2.5 the corresponding sections of standards DIN EN60950-1, EN60950-1, UL60950-1, CAN/CSA-C22.2 No. 60950-1 can be applied.

2.3. Notes on Transport, Storage and Handling



Encoder

- Use only the original packaging for transportation!
- If possible, use only the original packaging for storage.

SINGLEFLEX Scale Tape

- Can be rolled up (minimum bending radius = 140 mm).
- No restrictions regarding to the length.

DOUBLEFLEX Scale Tape

- In no case the DOUBLEFLEX scale tape should be stored, transported or used when rolled up!
- Use only the original packaging for transportation!
 - Lengths up to 3 m - stretched out
 - Lengths above 3 m - tape laid down as a figure eight
- Use only the original packaging for storage!
- Damages to the adhesive layer between the scale tape and carrier tape must absolutely be avoided, since otherwise the measuring properties of the DOUBLEFLEX scale tape are lost.
- Only remove the DOUBLEFLEX scale tape from the packaging on site, directly before mounting.
- Do not separate the scale tape and carrier tape from each other! Avoid any unintentional separation of the scale tape from the carrier tape, even just partial separation.
- Avoid radial or axial offsetting between the scale tape and carrier tape.
- **If the scale tape should become partially or completely separated from the carrier tape - even for just a very short time - simply pressing them together again will not result in sufficient adhesion. In this case neither the operational reliability nor the metrological properties can be guaranteed anymore. Please return the scale tape to NUMERIK JENA GmbH for repair! Unfortunately a repair at the customer site is not possible.**
- When removing the DOUBLEFLEX scale tape from the packaging, the sag must not exceed more than 100 mm.
- After removing the greatest distance between two supports must not be more than 800 mm. Scale tapes up to 1,200 mm must be supported approx. 300 mm from the ends and longer scale tapes must be supported correspondingly.

2.4. Notes on Operation



- Do not connect or disconnect plugs if the power is on!
- Only operate the encoder with the supply voltage stated in this product data sheet.
- Comply with applicable PIN assignment if auxiliary electronic units are connected (e.g. controller or display)!
- Integrate exposed encoders in instruments, devices or machines in such a way that they are protected against contamination.
- Protect the scale tape against mechanical damage.
- Protect the scanning head against shock, impact and humidity.

2.5. Notes on Maintenance

- The encoder requires no maintenance whatsoever, but must be cleaned occasionally, depending on the ambient conditions.
- Modifications and repairs of the encoder may only be carried out by NUMERIK JENA GmbH or appropriately authorized persons.
- NUMERIK JENA GmbH is not liable for damages caused by unauthorized handling of the encoder. All warranty claims are forfeited by unauthorized handling.
- Exposed measuring systems are sensitive to contamination, especially the scale surface and the scanning windows for the counting and reference tracks on the scanning head.
- Particularly critical are rough and irregular contamination and deposits (e.g. oil, grease or water).
- The user has to protect the encoder from contamination by way of appropriate design measures.



- **When cleaning the encoder, ensure that no solvent flows under the scale tape!**
- **When cleaning the components, ensure that the scanning window and scale tape are not scratched by any deposited particles!**
- **Please also pay attention to the notes in chapter 11 „Cleaning“.**

3. Setup of the Rotary Kit Encoder

3.1 Setup with Signal Processing in a D-Sub Connector

This setup consists of the following components:

- EPIFLEX sensor module glued into a very flat frame
- Scale tape with incremental and index track
- Connector PCB to connect flex cable with round cable of the connector
- Connector with integrated electronics ($1 V_{PP}$ or RS 422) and cable

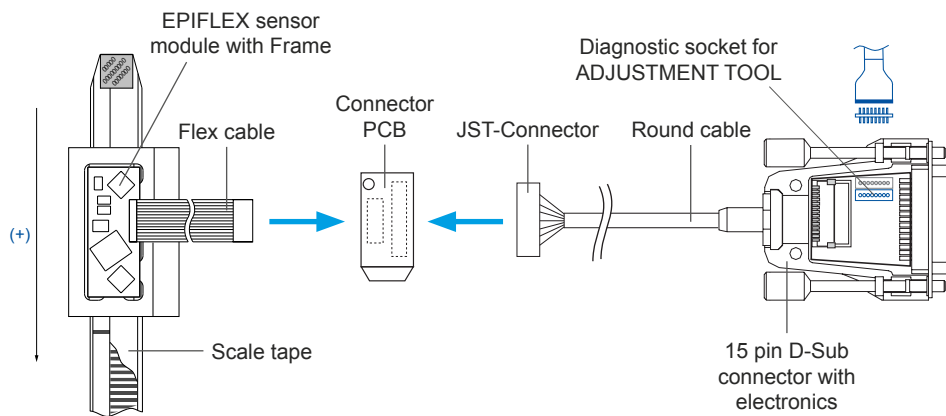

Image 1

3.2 Setup with Signal Processing on a Connector PCB

This setup consists of the following components:

- EPIFLEX sensor module glued into a very flat frame
- Scale tape with incremental and index track
- Connector PCB with integrated electronics ($1 V_{PP}$ or RS 422)
- Connector with cable

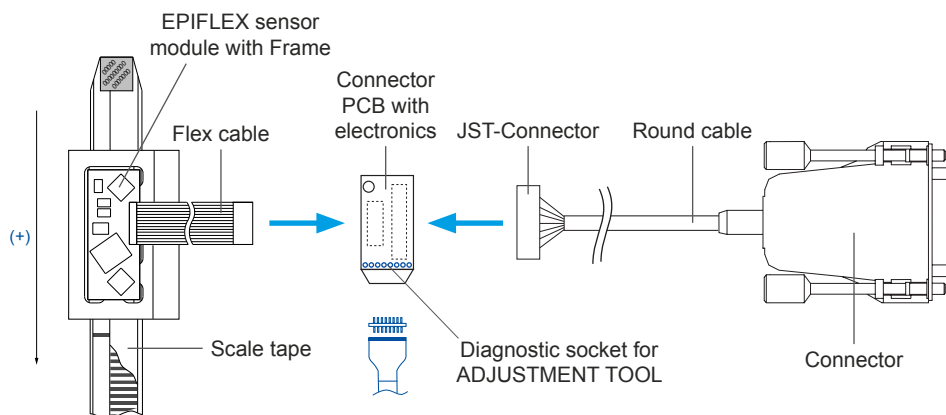

Image 2

3.3 Setup without Signal Processing

This setup consists of the following components:

- EPIFLEX sensor module glued into a very flat frame
- Scale tape with incremental and index track

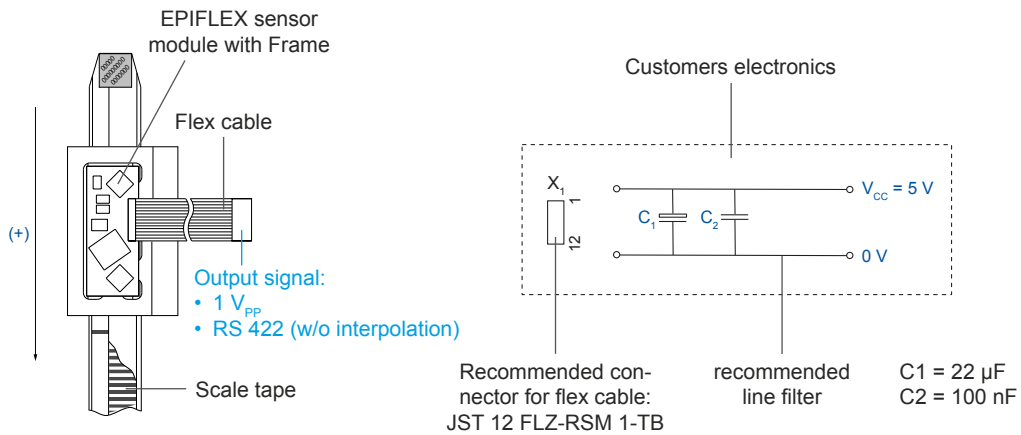

Image 3

Attention: To adjust this Kit R4 setup electronically it is necessary to integrate the following circuitry. The connection between the ADJUSTMENT TOOL and the PCB will be done with an 8 pin plug connector (included with the ADJUSTMENT TOOL).

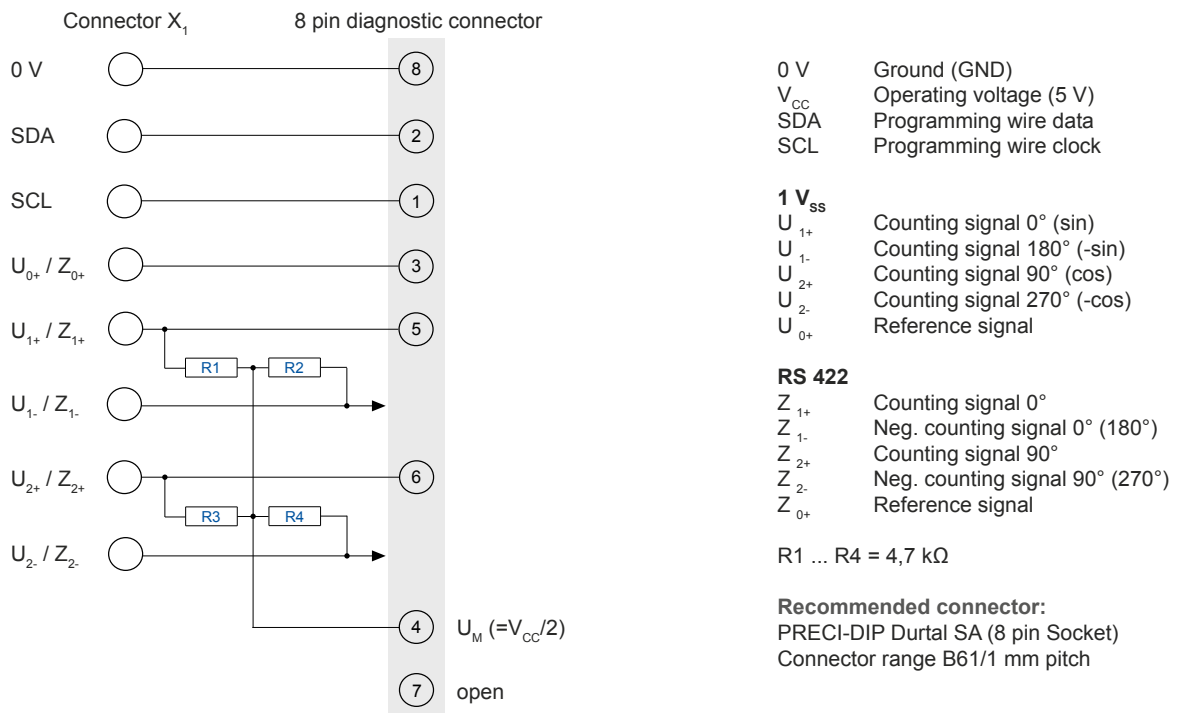

Image 4

3.4 Features Kit L2

The Kit L2 encoders from NUMERIK JENA are 2-field scanning units. The advantage compared with 1-field scanning units is a lower sensitivity to contaminations.

Sensor layout:

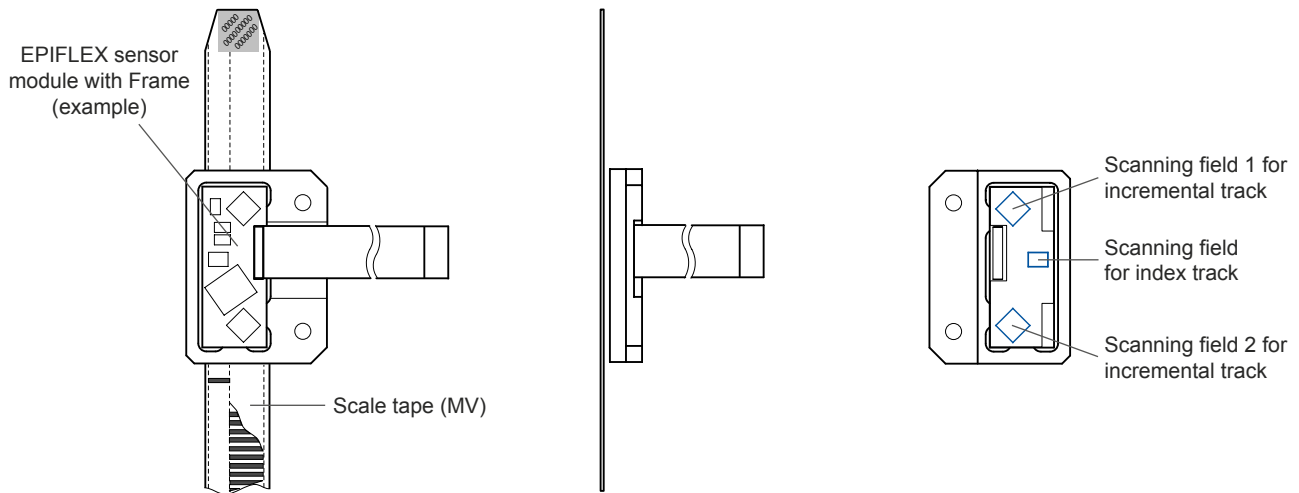

Image 5

3.5 Features Kit L4

The Kit L4 encoders from NUMERIK JENA are 1-field scanning units. The advantage compared with 2-field scanning units is a smaller frame size.

Sensor layout:

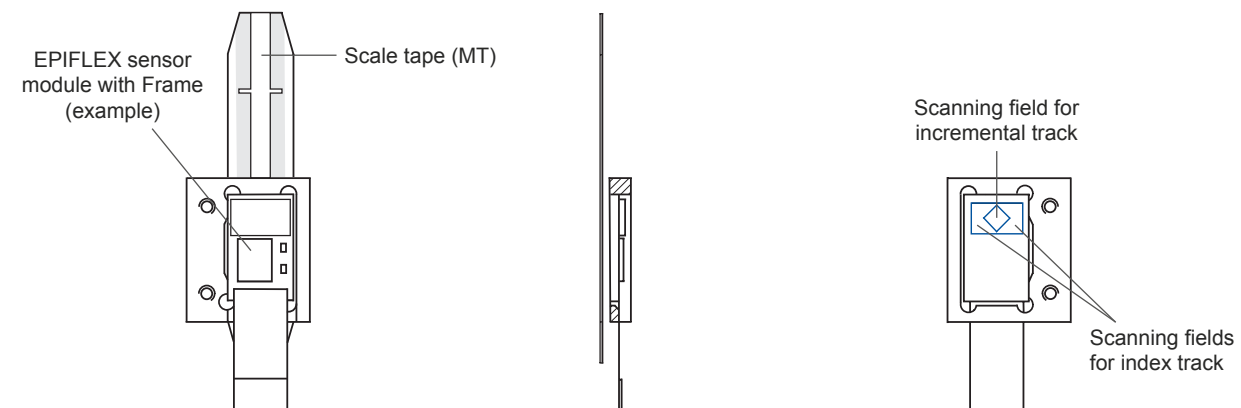

Image 6

4. SINGLEFLEX Scale Tape

The SINGLEFLEX scale tape from NUMERIK JENA consists of a single stainless steel tape with an applied incremental track and one or more reference marks. The scale tape is equipped with a double-sided adhesive tape and can be mounted easily on the machine element.

The SINGLEFLEX scale tapes are available in two different types, “MV” and “MT”. They differentiate oneself from the kind of the applied incremental and index track.

- **MV** with asymmetric index track for 2-field scanning, suitable for Kit L2
- **MT** with symmetric index track for 1-field scanning, suitable for Kit L4

4.1 Setup SINGLEFLEX MV

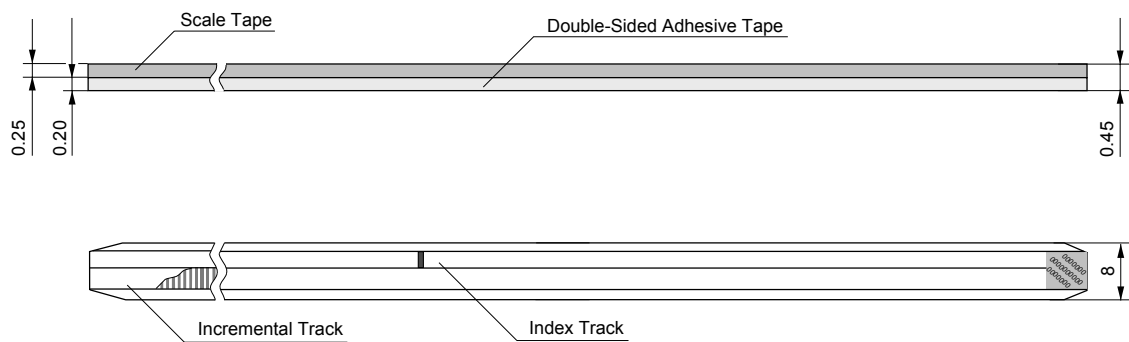

Image 7

4.2 Setup SINGLEFLEX MT

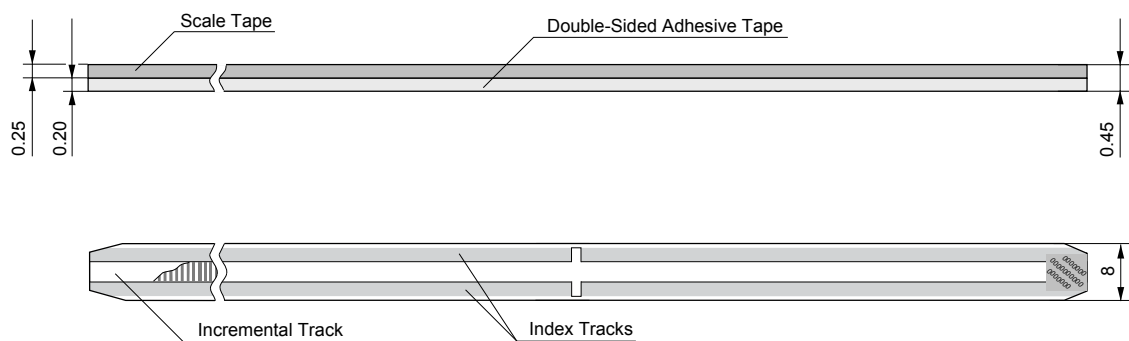

Image 8

5. DOUBLEFLEX Scale Tape

The DOUBLEFLEX-scale tape consists of two superimposed steel tapes. Both of them are divided by a tension uncoupled sheen of oil which ensures the adhesion between the steel tapes. The incremental track and one or more reference marks are applied on the upper steel tape. The lower steel tape is equipped with a double-sided adhesive tape and can be mounted easily on the machine element.

The two steel tapes are uncoupled mechanically. This ensures that the upper steel tape can expand independently of the lower steel tape due to thermal variations of the ambient temperature. By reference of the ambient temperature and the expansion coefficient of the steel tape it is possible to determine occurring length deviation of the increments. This allows to subtract out the deviation of the measurement results.

The DOUBLEFLEX scale tapes are available in two different types, "MV" and "MT". They differentiate oneself from the kind of the applied incremental and index track.

- **MV** with asymmetric index track for 2-field scanning, suitable for Kit L2
- **MT** with symmetric index track for 1-field scanning, suitable for Kit L4

5.1 Setup DOUBLEFLEX MV

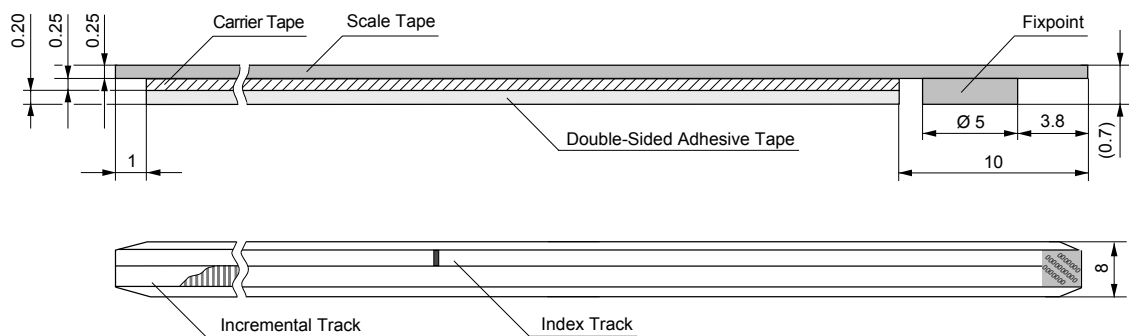

Image 9

5.2 Setup DOUBLEFLEX MT

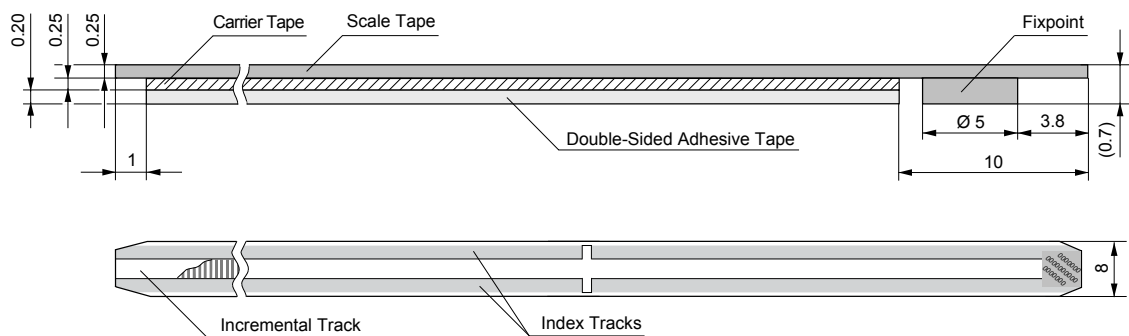

Image 10

6. Technical Data

6.1 Resolution and Accuracy (Definition)

Basically one has to differentiate between the resolution and the accuracy of a measuring system. The two parameters are not directly interdependent and may differ from each other.

Resolution

The resolution of linear system describes the least possible displacement of scanning head against the scale which can still be discerned by the evaluation electronics (display, control). It depends on (see chart 1)

- the graduation period of the scale
- the signal interpolation factor (internally or in auxiliary electronic unit)
- the evaluation mode in the counter

Accuracy

The accuracy of linear measuring systems is specified in accuracy classes.

The extreme error values for any max. one-meter section of the measured length lie within the specified accuracy class of $\pm a \mu\text{m}$ with respect to their mean value.

For measuring length up to 1 m, the tolerance ($\pm a \mu\text{m}$) refers to the actual measuring lengths. The accuracy applies to a reference temperature of 20°C.

With exposed linear measuring systems, the definition of the accuracy class applies only to the scale. This is called scale accuracy.

Grating period of scale tape	Signal period of sinusoidal signals	Interpolation factor	Signal period after interpolation	Resolution after evaluation in counter	
				2-times	4-times
20 μm	20 μm	none	20 μm	10 μm	5 μm
		5-times	4 μm	2 μm	1 μm
		10-times	2 μm	1 μm	0.5 μm
		25-times	0.8 μm	0.4 μm	0.2 μm
		50-times	0.4 μm	0.2 μm	0.1 μm
		100-times	0.2 μm	0.1 μm	0.05 μm

Chart 1

6.2 Mechanical Data

	Kit L2	Kit L4
Dimensions of scan head	20 mm x 8 mm	13 mm x 8 mm
Weight of sensor	2.5 g	2 g
recommended measuring steps	0.05 µm, 0.1 µm, 0.2 µm, 0.5 µm, 1.0 µm, 5.0 µm	
Traversing speed		
Maximum	10 m/s (without interpolation)	
Depending on the evaluation electronics	see chart 4	
Scale tape		
Material	Stainless Steel	
Grating period (TP)	20 µm	
Reference marks	<ul style="list-style-type: none"> • Periodic at a distance of 50 mm¹ • In the middle of the measuring length (ML) • Distance coded at 1,000 x TP¹ • Others on request 	
Measuring length (ML)		
SINGLEFLEX scale tape	up to 30 m	
DOUBLEFLEX scale tape ²	up to 5 m	
Linear thermal expansion coefficient		
SINGLEFLEX scale tape	10.6 x 10 ⁻⁶ K ⁻¹ (expansion will be influenced by the mounting surface)	
DOUBLEFLEX scale tape ²	10.6 x 10 ⁻⁶ K ⁻¹	
Accuracy classes (a)		
SINGLEFLEX, DOUBLEFLEX ² scale tape	±1 µm ±2 µm ±3 µm ±5 µm	
Cable		
Cable diameter	3.7 mm	
Permissible bending radius	<ul style="list-style-type: none"> • Occasional flexing ~8 mm • Constant flexing ~40 mm 	
From scan head to the D-Sub connector	0.3 m, 0.5 m, 1.0 m, 1.5 m, 2.0 m, 3.0 m (other on request)	
From D-Sub connector to the controller (extension cable)	max. 100 m (The necessary supply voltage must be ensured!)	

¹ not for Kit L4

² not suitable for vacuum application

6.3 Electrical Data

	Kit L2	Kit L4
Scanning frequency	max. 500 kHz	
Supply voltage	5 V \pm 10%	
Output interfaces		
Voltage output	1 V _{PP}	
Square wave output	RS 422 with interpolation up to 100-times	
Current consumption		
Voltage output	\leq 90 mA*	\leq 80 mA*
Square wave output	\leq 220 mA*	\leq 210 mA*

* with 120 Ω load resistance

Chart 3

6.4 Switch-On Behaviour

During power-up procedure of the encoder system the level of power voltage and signal lines must be below 250 mV.



If the encoder system will be powered-up at a residual voltage between a range of 250 and 400 mV, internal sensor parameter will not set correctly. This will lead to incorrect encoder signals.

This behaviour has to be observed especially during reset routines of controllers.

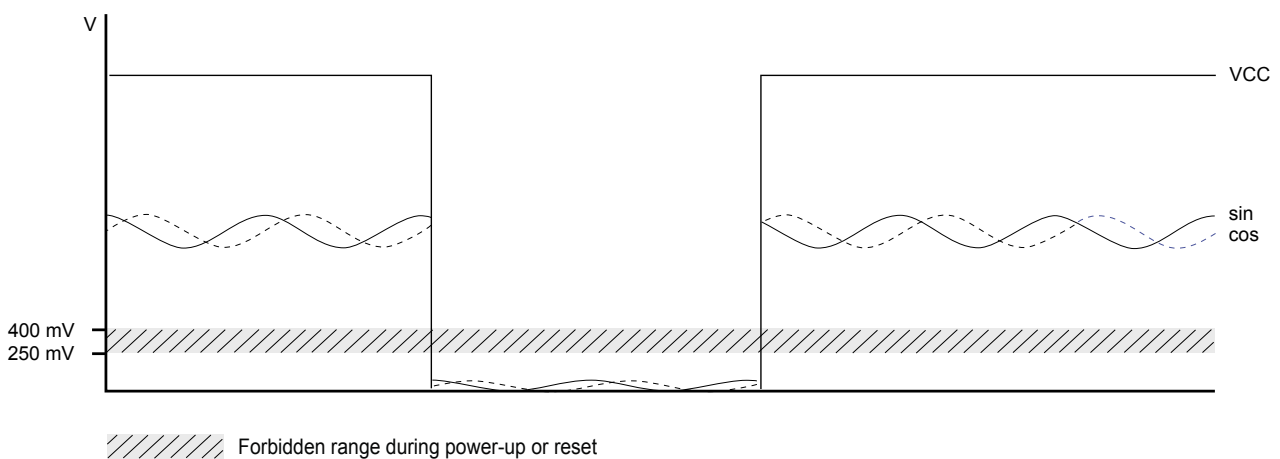

Image 11

6.5 Attainable Traversing Speed

The maximum attainable traversing speed of the encoder is determined by the maximum output frequency of the interpolator and/or the maximum counting frequency of the operator's evaluation electronics.

In order to avoid counting errors, the interpolator's output frequency is matched to the counting frequency of the operator's evaluation electronics.

This adaptation is possible in discrete frequency steps.

The maximum attainable traversing speed (v_{\max}) is calculated according to the following formula:

$$v_{\max} = \frac{f \cdot TP}{i \cdot SF \cdot 4} \quad [\text{m/s}]$$

- f Output frequency set by the manufacturer for 4-times evaluation by the interpolator [MHz]
- TP Grating period [μm]
- i Interpolation factor (5-times, 10-times, 25-times, 50-times oder 100-times)
- SF Safety factor = 1.5

v_{\max} dependent on the interpolation factor and the clock frequency of the counter

Interpolation	w/o	5-times		10-times		25-times		50-times		100-times	
Resolution (μm)	5	1		0.5		0.2		0.1		0.05	
Min. clock frequency of the counter (MHz)	2	4	16	4	24	4	24	4	24	4	24
Min. edge separation (μs)	0.5	0.25	0.063	0.25	0.042	0.25	0.042	0.25	0.042	0.25	0.042
Max. traversing speed (m/s)	10	2.66	10	1.33	8	0.53	3.2	0.27	1.6	0.13	0.8

• with 4-times evaluation

Chart 4

6.6 Ambient Conditions

	Kit L
Operating temperature range	0°C to +55°C (+32°F to +131°F)
Storage temperature range	-20°C to +70°C (-4°F to +158°F)
Vibration (50 Hz ... 2,000 Hz)	≤200 ms ⁻² (20 g)
Shock (11 ms)	≤400 ms ⁻² (40 g)
Humidity	≤93% relative humidity (no condensation forming)

Chart 5

6.7 Cable

Scanning Head Cable (connection cable from connector PCB to D-Sub connector)

- Provide a strain relief for the cable near the connector PCB.
- The encoder cables and connecting cables must be laid away from sources of interference (e.g. mains cables, fuses, motors, magnetic valves or power supplies). Normally a distance of ≥100 mm will be sufficient.
- Install the cable in a way that it cannot be damaged by the rotating hub. Please pay attention to the permissible bending radius (see also point 6.2!)

Extension Cable (connection cable from D-Sub connector to controller)

- Use preferably original extension cables made by NUMERIK JENA. This guarantees an optimum compatibility with the encoders and ensures a maximum protection against electromagnetic interferences.
- Please consult the technical support of NUMERIK JENA before using selfmanufactured extension cables.
- Do not install any other signal lines in the encoder cable!

6.8 Connector PCB

6.8.1 Type 1 with Signal Processing

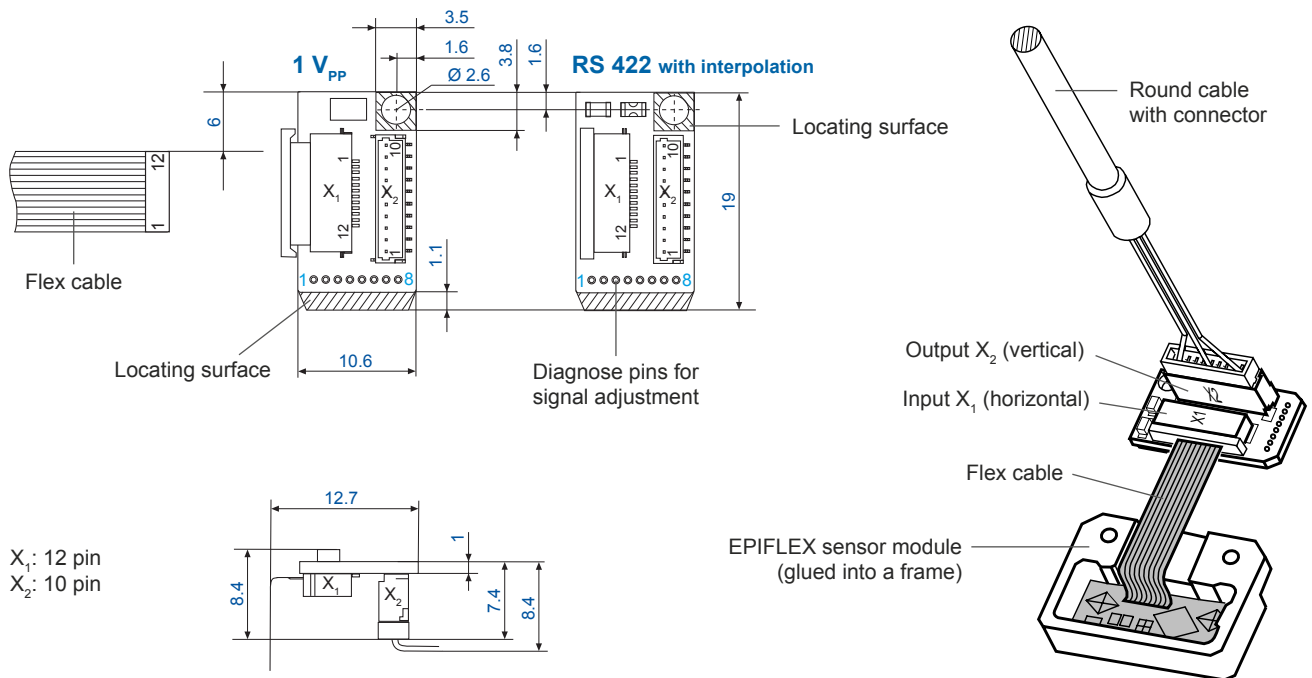

Image 12

6.8.2 Type 2 with Signal Processing

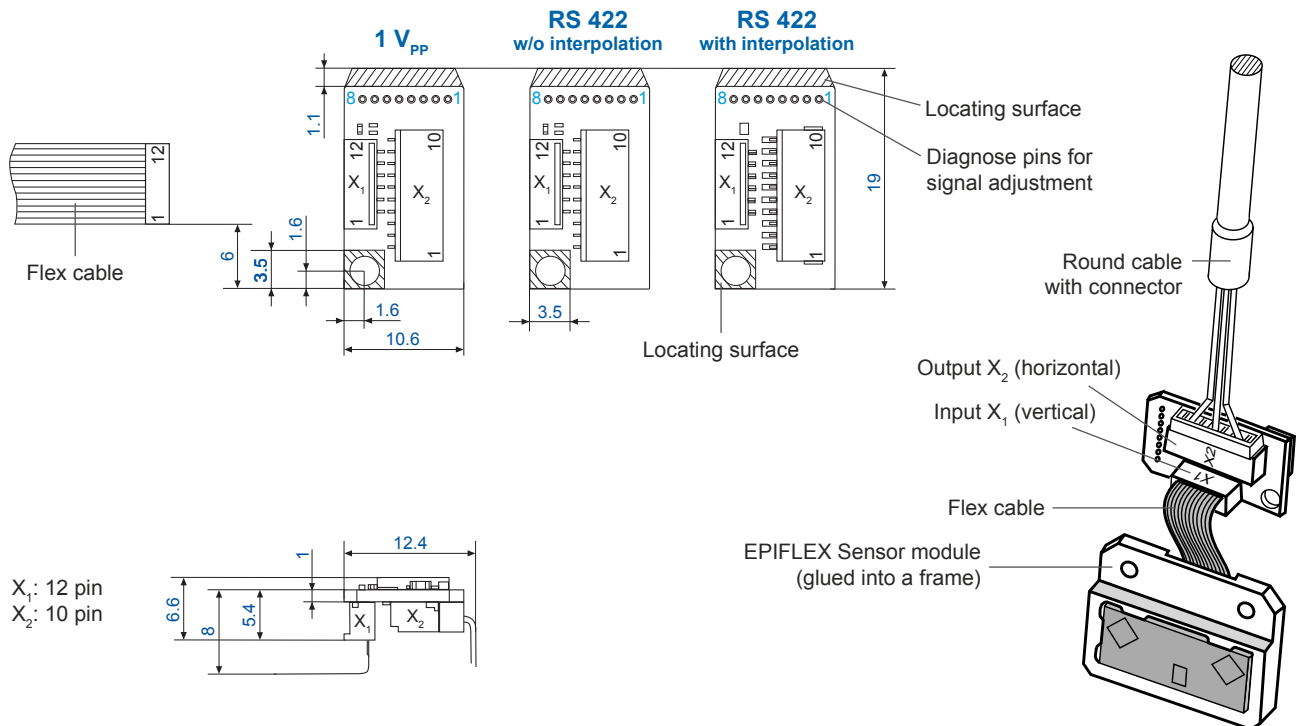

Image 13

6.8.3 Type 2 without Signal Processing

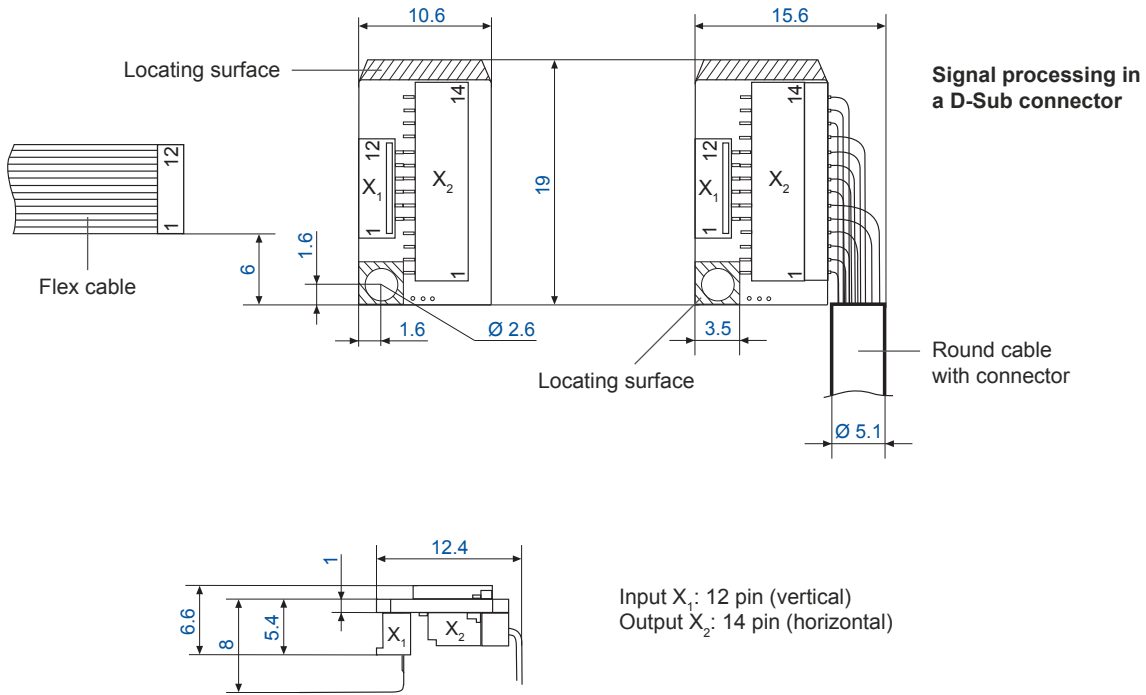

Image 14

6.9 Dimensions Connector Cable with Open Output

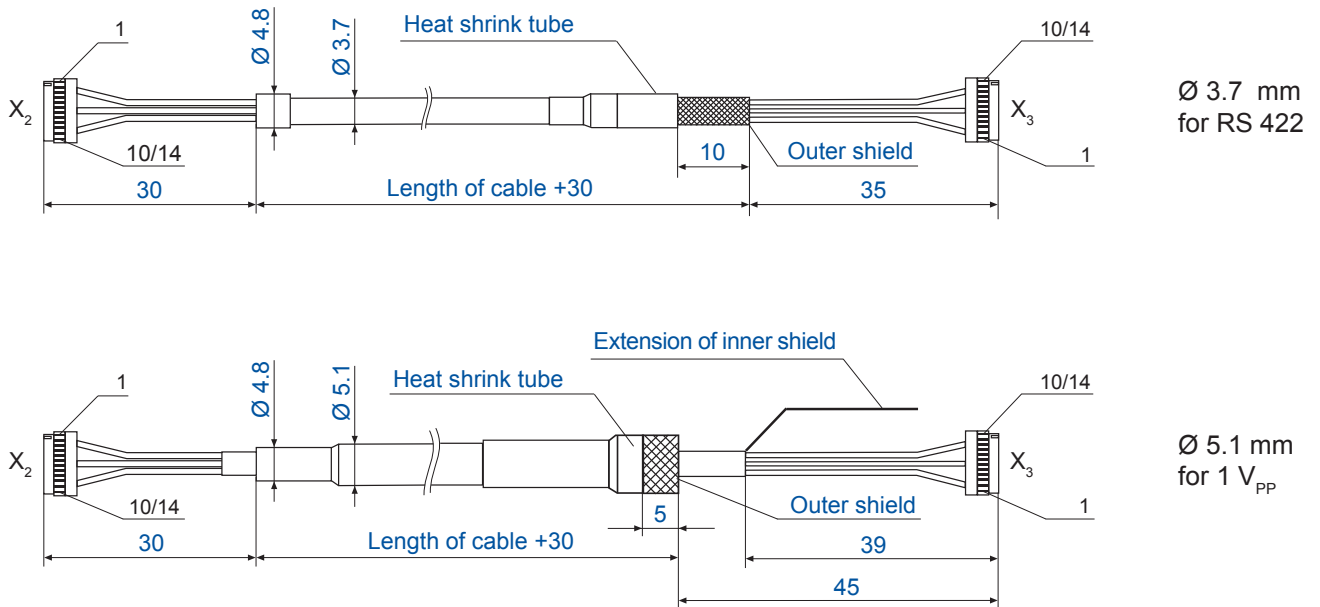

Image 15

6.10 Connector Variants

Type	Image connector	Pins
15-pin D-Sub		
9-pin D-Sub		
12-pin round connector (Plastic-coated connector)		
12-pin round connector (Plastic-coated coupling)		

Chart 6

6.11 PIN Assignment

15 pin D-Sub Connector

PIN	1	2	3	4	5	6	7	8	9	10	11	12	13	14	15	Housing
1 V _{PP}	-	-	-	U ₀₋	U ₂₋	U ₁₋	-	5V	0V	-	-	U ₀₊	U ₂₊	U ₁₊	Inner shield	Outer shield
RS 422	-	-	NAS	Z ₀₋	Z ₂₋	Z ₁₋	-	5V	0V	-	AS	Z ₀₊	Z ₂₊	Z ₁₊	Inner shield*	Outer shield
Cable Ø 3.7 mm	-	-	vt	pk	rd	bn	-	bu	wh	-	ye	gy	bk	gn	-	-
Cable Ø 5.1 mm	-	-	vt	pk	rd	ye	-	bn	wh	-	bk	gy	bu	gn	wh/gy	-

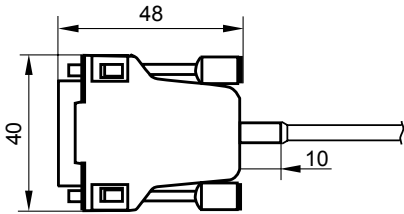
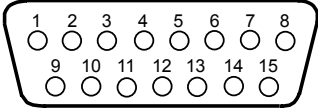
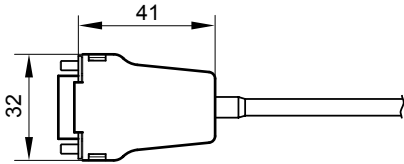
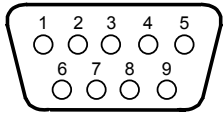
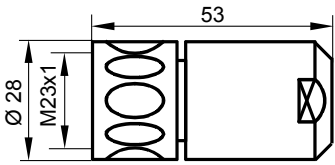
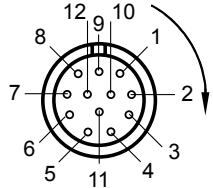
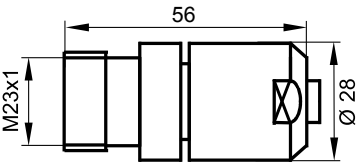
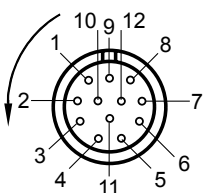
* for signal processing in the 15-pin D-sub connector

9 pin D-Sub Connector

PIN	1	2	3	4	5	6	7	8	9	Housing
1 V _{PP}	U ₁₋	0V	U ₂₋	Inner shield*	U ₀₋	U ₁₊	5V	U ₂₊	U ₀₊	Outer shield
RS 422	Z ₁₋	0V	Z ₂₋	NAS	Z ₀₋	Z ₁₊	5V	Z ₂₊	Z ₀₊	Outer shield
Cable Ø 3.7 mm	bn	wh	rd	vt	pk	gn	bu	bk	gy	-
Cable Ø 5.1 mm	ye	wh	rd	vt	pk	gn	bn	bu	gy	-

* in the case of 1 V_{PP} the violet wire remains unused, the inner shield (extended with wire color white/green) will be connected instead

12 pin Round Connector

PIN	1	2*	3	4	5	6	7	8	9	10*	11*	12*	Housing
1 V _{PP}	U ₂₋	5V	U ₀₊	U ₀₋	U ₁₊	U ₁₋	-	U ₂₊	Inner shield	0V	0V	5V	Outer shield
RS 422	Z ₂₋	5V	Z ₀₊	Z ₀₋	Z ₁₊	Z ₁₋	NAS	Z ₂₊	-	0V	0V	5V	Outer shield
Cable Ø 3.7 mm	rd	bl	gy	pk	gn	bn	vt	bk	wh/gn	wh	wh	bu	-
Cable Ø 5.1 mm	rd	bn	gy	pk	gn	ye	vt	bu	-	wh	wh	br	-

* PIN 2 and 12 bridged, PIN 10 and 11 bridged

1 V_{PP}

U ₁₊	Counting signal 0° (sin)
U ₁₋	Counting signal 180° (-sin)
U ₂₊	Counting signal 90° (cos)
U ₂₋	Counting signal 270° (-cos)
U ₀₊	Reference signal
U ₀₋	Neg. reference signal

0V	Ground (GND)
5V	Operating voltage (U _B)
AS	Error signal (monitoring signal)
NAS	Neg. error signal

NAS high: Input signal within the tolerance range
 NAS low: Input signal outside the tolerance range (check measuring system!)

RS 422

Z ₁₊	Counting signal 0°
Z ₁₋	Neg. counting signal 0° (180°)
Z ₂₊	Counting signal 90°
Z ₂₋	Neg. counting signal 90° (270°)
Z ₀₊	Reference signal
Z ₀₋	Neg. reference signal

SCL	Programming wire clock
SDA	Programming wire data

6.12 PIN Assignment for Connector PCB X₁

PIN	1	2	3	4	5	6	7	8	9	10	11	12
1 V _{SS}	SCL	SDA	GND	-	U ₁₋	U ₁₊	NAS	U ₀₊	U ₀₋	U ₂₋	U ₂₊	5V
RS 422	SCL	SDA	GND	-	Z ₁₋	Z ₁₊	NAS	Z ₀₊	Z ₀₋	Z ₂₋	Z ₂₊	5V

6.13 PIN Assignment for JST Miniature Connector X₂ and X₃

10 pin JST Miniature Connector

PIN	1	2	3	4	5	6	7	8	9	10	
1 V _{PP}	U ₂₋	0V	-	U ₂₊	U ₀₋	-	U ₁₋	U ₀₊	U ₁₊	5V	Inner shield
RS 422	Z ₂₋	0V	NAS	Z ₂₊	Z ₀₋	AS	Z ₁₋	Z ₀₊	Z ₁₊	5V	-
Cable Ø 3.7 mm	rd	wh	vt	bk	pk	ye	bn	gy	gn	bu	-
Cable Ø 5.1 mm	rd	wh	-	bu	pk	-	ye	gy	gn	bn	wh/gn

14 pin JST Miniature Connector

PIN	1	2	3	4	5	6	7	8	9	10	11	12	13	14	
1 V _{PP}	0V	U ₁₋	-	SCL	SDA	-	U ₁₊	U ₀₊	U ₂₋	5V	U ₂₊	U ₀₋	S2	S1	Inner shield
RS 422	0V	Z ₁₋	NAS	SCL	SDA	-	Z ₁₊	Z ₀₊	Z ₂₋	5V	Z ₂₊	Z ₀₋	S2	S1	
Cable Ø 5.1 mm	wh	ye	vt	bk	bn/gn	-	gn	gy	rd	bn	bu	pk	wh/ye	ye/bn	wh/gn

1 V_{PP}

U₁₊ Counting signal 0° (sin)
 U₁₋ Counting signal 180° (-sin)
 U₂₊ Counting signal 90° (cos)
 U₂₋ Counting signal 270° (-cos)
 U₀₊ Reference signal
 U₀₋ Neg. reference signal

0V Ground (GND)
 5V Operating voltage (U_B)
 AS Error signal (monitoring signal)
 NAS Neg. error signal

NAS high: Input signal within the tolerance range
 NAS low: Input signal outside the tolerance range (check measuring system!)

RS 422

Z₁₊ Counting signal 0°
 Z₁₋ Neg. counting signal 0° (180°)
 Z₂₊ Counting signal 90°
 Z₂₋ Neg. counting signal 90° (270°)
 Z₀₊ Reference signal
 Z₀₋ Neg. reference signal

SCL Programming wire clock
 SDA Programming wire data

6.14 Electromagnetic Compatibility (EMC)



Please observe the following to ensure maximum protection against electrical and magnetic fields:

- The encoder must be mounted to a galvanic conductive surface. The mounting surfaces, the threads of the mounting screws and the threads in the machine must be free from electrically non-conductive coatings.
- Maintain the NUMERIK JENA shielding concept for the measuring system!
- Shielding for encoders without connectors:
 - When connected directly with the evaluation electronics, ensure that the external shield of the cable is well grounded
 - If cable connectors (e.g. terminal strips, etc.) are used, connect the external shields of the cables with each other and with the shielding of the cable connector
- When using additional electronics, connect the housing electrically conducting to ensure good galvanic conductivity. For insulated installation the housing should be connected at the shortest distance by an additional potential equalization line (Cu line with cross section $\geq 6 \text{ mm}^2$) with the machine's protective ground.
- Please contact the NUMERIK JENA support or that of the appropriate manufacturer if you experience any problems when working with specific display or control units.

6.15 Shielding Concepts

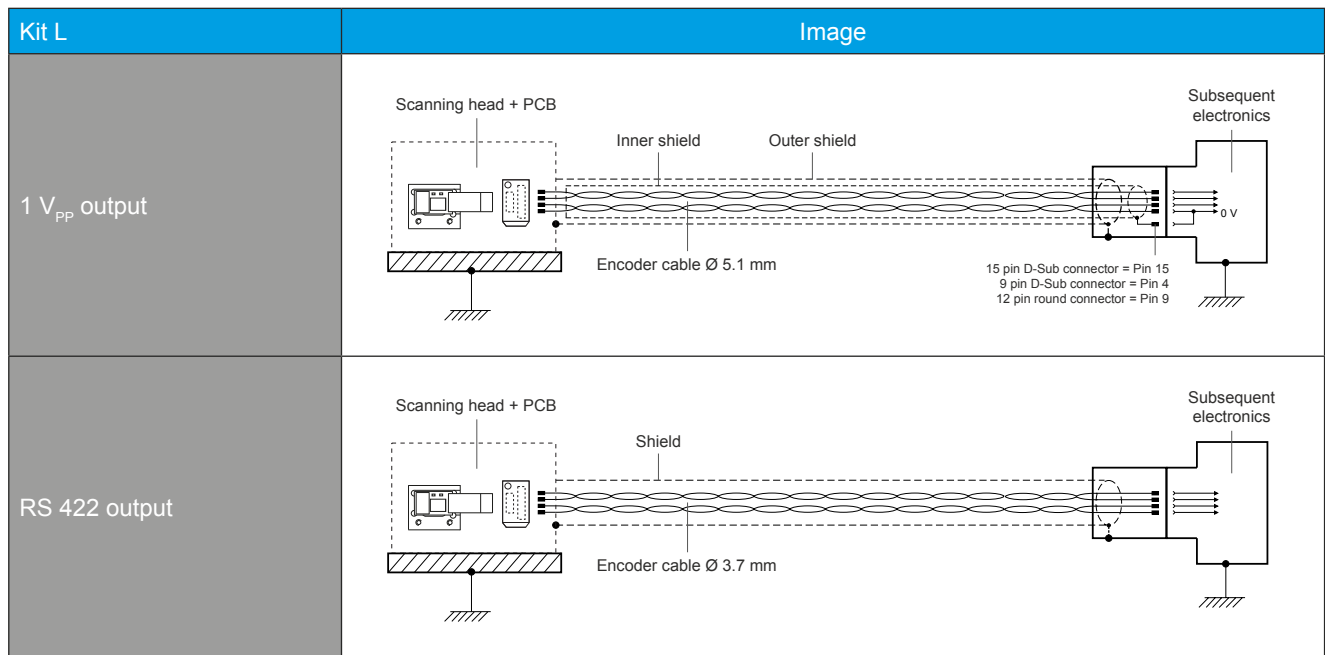

Chart 7

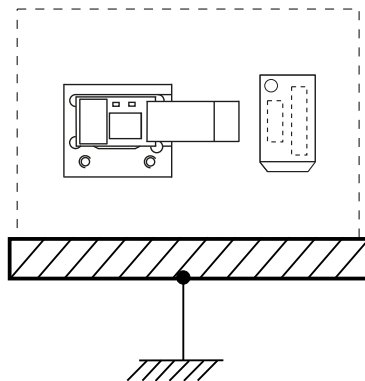

Image 16

ATTENTION! The user has to assure an EMC-compatible shielding of the scanning head and the PCB!

6.16 Voltage Output $1 V_{PP}$

Optimal Connection Circuit

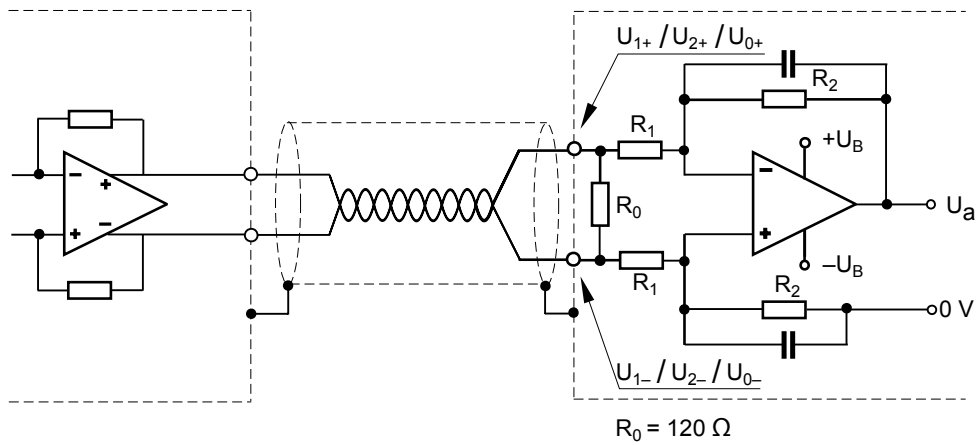

Image 17

Signal Curve

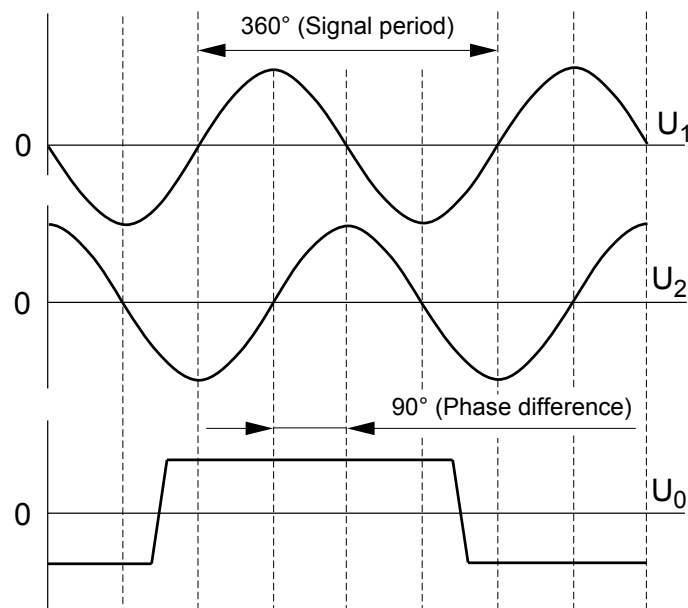

Image 18

Difference signals measured at R_0 :

$$U_1 = U_{1+} - U_{1-} = 0.6 \dots 1.2 V_{PP} \quad (\text{Rated voltage: } 1 V_{PP})$$

$$U_2 = U_{2+} - U_{2-} = 0.6 \dots 1.2 V_{PP} \quad (\text{Rated voltage: } 1 V_{PP})$$

$$U_0 = U_{0+} - U_{0-} = 0.5 \dots 1.2 V \quad (\text{Rated voltage: } 0.8 V)$$

6.17 Square-Wave Output RS 422

Optimal Connection Circuit

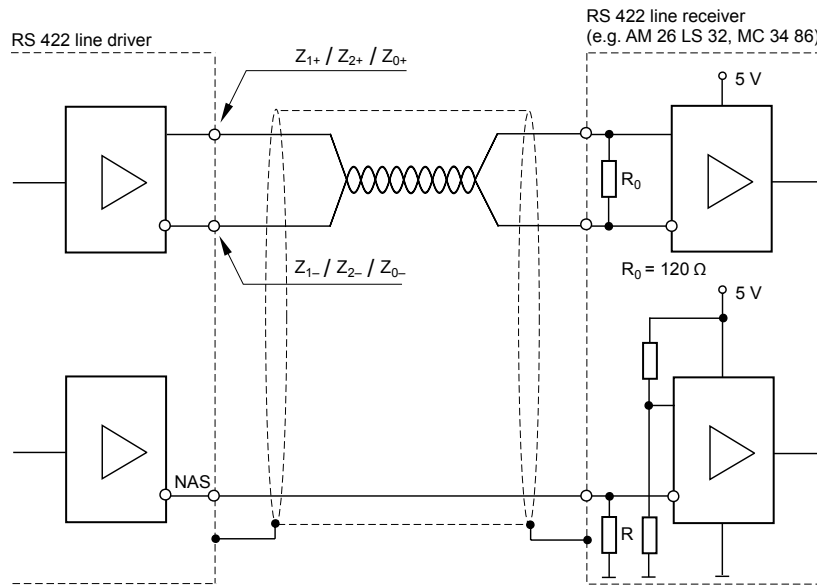

Image 19

Signal Curve

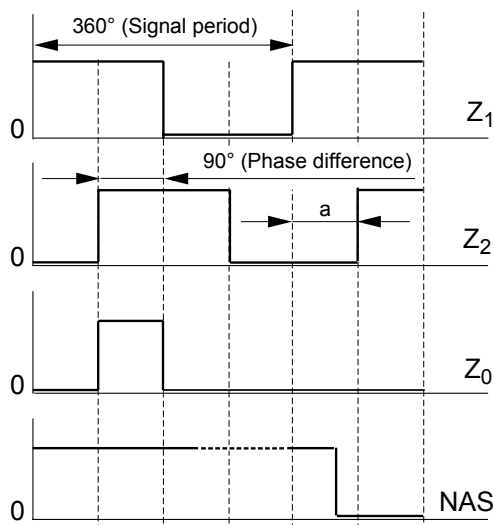

Image 20

NAS high:

Encoder functioning properly, input signals within tolerance range

NAS low:

Check the measuring system

a:

Minimum edge separation as a function of the interpolation factor and traversing speed

In order to avoid electromagnetic interference, the cable adaptation with a terminal resistor of $R_0 = 120 \Omega$ is necessary. When connecting more than one parallel signal input to an encoder output signal (e.g. linear motors with parallel connection to position controller, speed controller or acceleration controller) ensure that the resulting terminal resistance of these inputs is $R_{0res} \approx 120 \Omega$.

6.18 Online Compensation (Offset and Amplitude Control)

Contamination and mounting errors lead to interferences in the optical scanning of the scale by the scanning head and so to periodic deformations of the sinusoidal counting track signals, which are exemplified as

- Offset deviations
- Amplitude deviations
- Amplitude differences between the sine and cosine channels and lead to interpolation errors.

Contaminated Scale Tape

Scanning head signal with contaminated grating disk before activation of the online compensation.

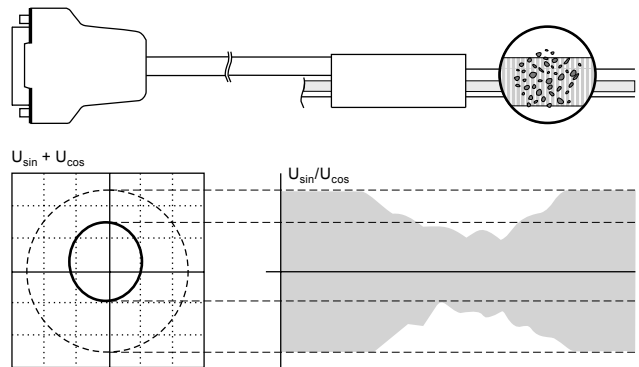

Image 21

Incorrect Mounting

Scanning head signal with faulty mounting before activation of the online compensation.

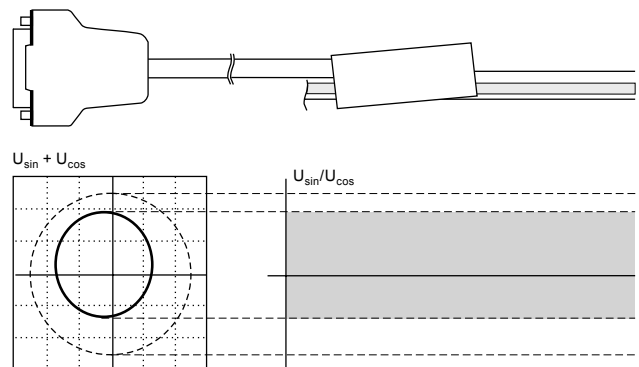

Image 22

Active Online Compensation

Scanning head signal with contaminated grating disk and/or faulty mounting after activation of the online compensation.

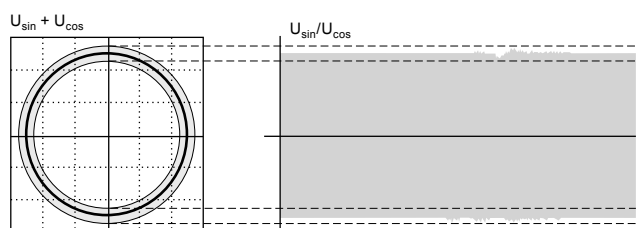

Image 23

Through the offset and amplitude control the signals generated by the measuring module are automatically corrected within the sensor without following error over the entire velocity range.

This measure not only increases the accuracy, but also the reliability of the encoder.

7. General Installation Notes

7.1 Delivery Contents

Standard

- Kit L2 and Kit L4 scanning head (according to the ordered specification)
- SINGLEFLEX or DOUBLEFLEX scale tape (according to the ordered specification)
- Spacing gage for mounting the scanning head (made of plastic with marking „0,6“)
- Information sheet

Optional

- ADJUSTMENT TOOL
- Extension cable

7.2 Installation Position



- The installation position of the measuring system is arbitrary.
- In order to avoid contamination deposits, a vertical position for the scale tape is recommended.
- The operator of the measuring system is responsible for appropriate design measures to protect the encoders from contamination.
- In any installation position the scale tape surface and scanning window of the scanning head should be easily accessible for cleaning. Prevent contamination and foreign elements from having an influence on the operation!
- Use preferably slots or edges as an installation orientation for straight mounting of the scale tapes, particularly very long ones.
- For DOUBLEFLEX scale tapes, slots and edges also serve as a stop to prevent any displacement between the scale tape and the carrier tape.
- The measuring properties of the DOUBLEFLEX scale tape are the result of the adhesive layer between the scale tape and the carrier tape. Do not displace the scale tape and carrier tape relative to each other, or separate them from each other!
- If you mount the DOUBLEFLEX scale tape vertically, the fixing point must be located at the top. Otherwise the scale tape can detach itself from the carrier tape!
- If you mount the DOUBLEFLEX scale tape perpendicular, the scale tape must lie on the carrier tape.

7.3 Mounting Steps



Hereafter the mounting steps for a Kit L measuring system from NUMERIK JENA will be described.

- Please read the notes mentioned to the particular mounting steps thorough and follow the indicated sequence of mounting steps exactly!
- The mounting steps for the Kit L2 and Kit L4 are basically the same.
- Maintain a tightening torque of 1 Nm for all screws!

1

- Preferably the tape should be mounted in a slot or along an edge.
- Please mark the future location of the scale tape before starting with the mounting.
- The alignment of the scale tape depends on the installation position of the scan head.
- Ensure that the scanning head's scanning fields for the counter and reference tracks are over the corresponding tracks on the scale tape (see also scheme step 5).

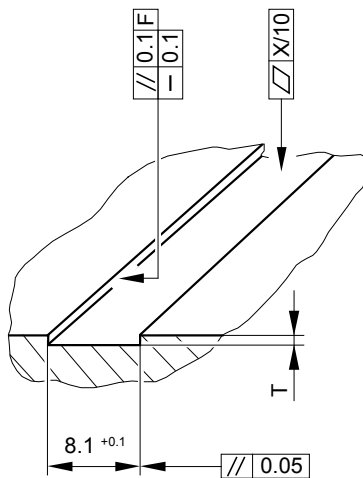

Mounting slot

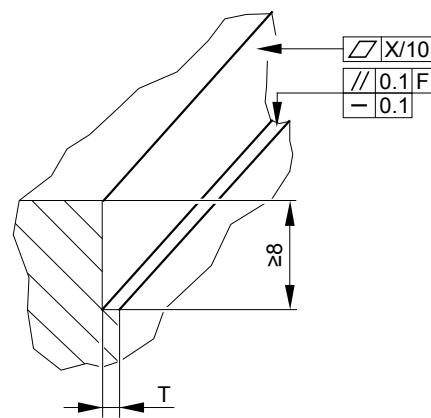

Mounting edge

Accuracy class	X
±1 μm	0.003
±2 μm	0.006
±3 μm	0.009
±5 μm	0.009

Scale tape	T
SINGLEFLEX	0.5 _{-0.1}
DOUBLEFLEX	0.7 _{-0.1}

F = Machine guideway

2

- Use a solvent to clean the adhesion surface of the machine (e.g. Acetone or Alcohol).
- Make sure that no contaminations remain on the machine's adhesion surface.
- Alien elements between the machine and scale tape cause local differences in the spacing between the scale tape and the scanning head. This may diminish the encoder's functionality and/or result in measuring errors.
- ATTENTION: Acetone and Alcohol are inflammable liquids!

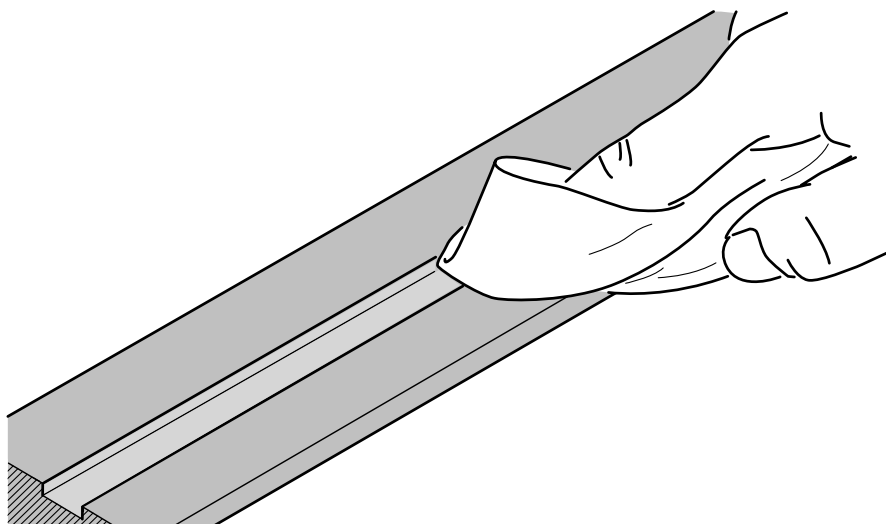

Information on installation of SINGLEFLEX and DOUBLEFLEX scale tapes



- The mounting steps of SINGLEFLEX and DOUBLEFLEX scale tapes are basically the same. But please pay attention to the following information on installation!
- The scale tape can be mounted in a slot already on the machine or along an edge already on the machine.
- Place the edge of the scale tape exactly on the marking for the beginning of the scale tape.
- Run the scale tape exactly along the slot or edge when applying it.
- If DOUBLEFLEX scale tapes are mounted vertically, mount them so that the scale tapes lie adjacent to the stop edge.

3

- If you use a DOUBLEFLEX scale tape, glue the fixing point first.
- Please pay attention to the use and safety instructions from the manufacturer of the adhesive!
- Place a drop of adhesive on the center of the fixing point.
- Recommended adhesives:
 - Cyanoacrylate adhesives such as Loctite 480 or Loctite 401
 - Epoxy resin

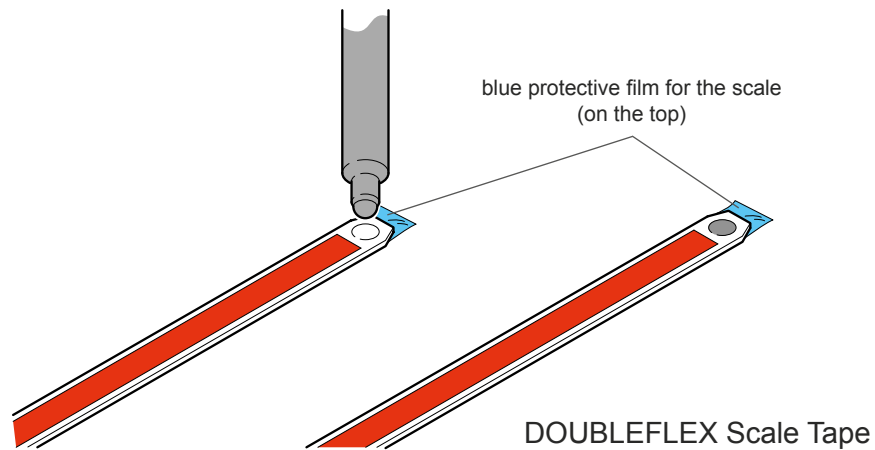

4

- Peel off ca. 70 mm of the red protective film on the back of the scale tape.
- The adhesive tape now exposed must not come into contact with other materials due to its strong adhesive force!
- Do not remove the blue transparent protective film from the scale tape yet!

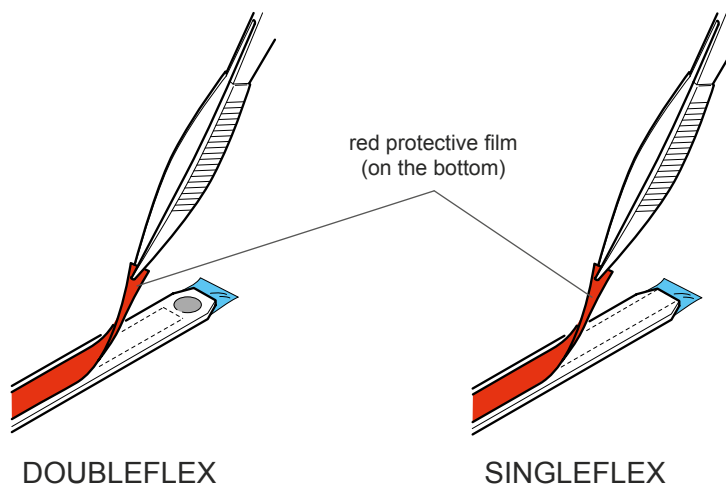

5

- Do not remove the blue transparent protective film from the scale tape yet!
- Remove the red protective film from the slot or edge.
- On the DOUBLEFLEX scale tape, apply the fix point with the drop of adhesive (at either the beginning or end of the scale tape) and at the same time secure the first ca. 50 mm of the scale tape.
- Place the end of the SINGLEFLEX scale tape from which the protective film has been removed against the front end stop (slot) or lateral stop (edge).

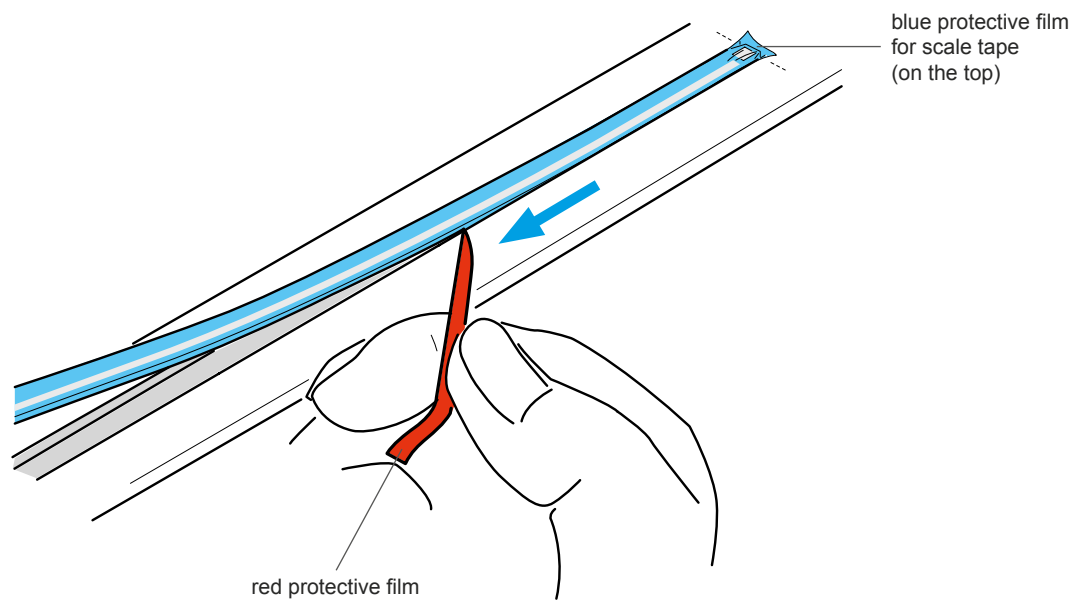

6

- Do not remove the blue transparent protective film from the scale tape yet!
- Press the scale tape with your forefinger and by the help of a soft, lint-free rag against the carrier over the entire length. Pull off the red protective film to the side. The pressure point should always be ca. 30 mm to 50 mm behind the point where the adhesive tape and the red protective film are being separated.
- **Only apply pressure to the scale tape from above and avoid lateral forces!**

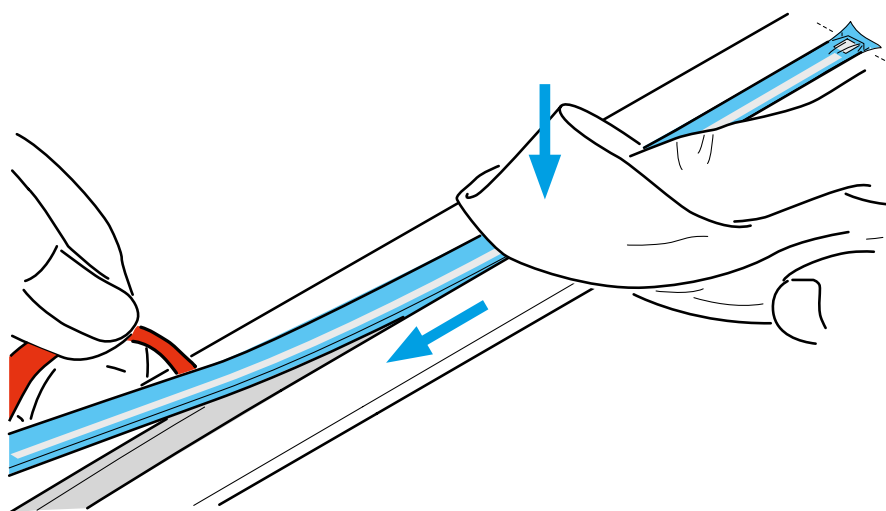

7

- Clean the mounting surfaces of the scanning head and the machine element.
- Remove the protective film from the scanning head.
- Clean the sensor surface of the scanning head with a soft and lint-free rag. Use a solvent if necessary (e.g. Acetone or Alcohol).
- **ATTENTION: Acetone and Alcohol are inflammable liquids!**

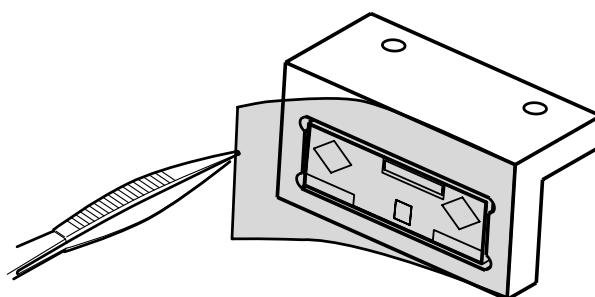

8

- Screw the scanning head onto the prepared mounting surface such that there is still some vertical clearance.
- Remove the blue transparent protective film (in case of DOUBLEFLEX scale tape, always begin at the fixing point) from the graduation of the scale tape.
- Clean the scale tape surface (graduation) of the scanning head with a soft and lint-free rag. Use a solvent if necessary (e.g. Acetone or Alcohol).
- ATTENTION: Acetone and Alcohol are inflammable liquids!

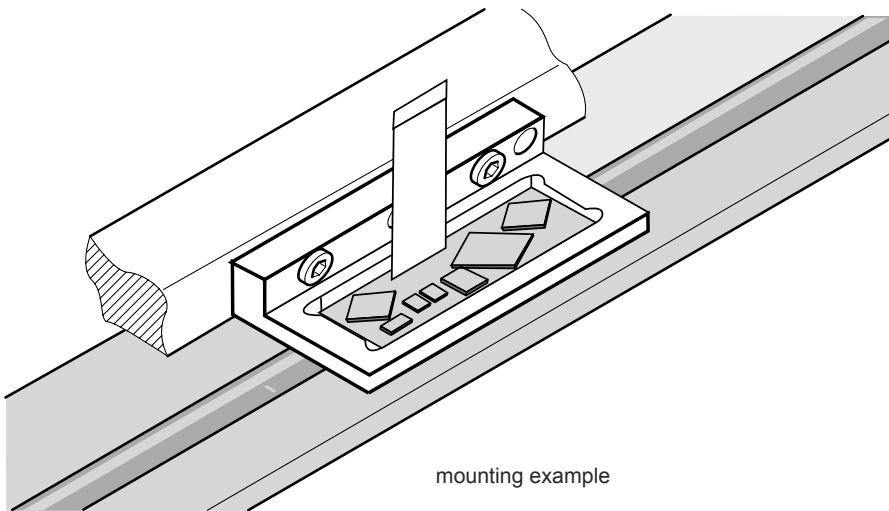

blue protective film

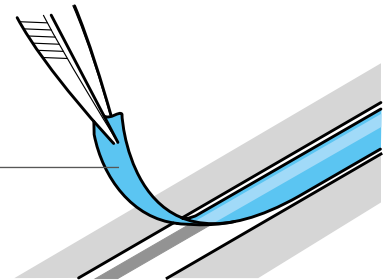

9

- Insert the spacing gage “0,6” lengthwise between the scale tape surface and the scanning head.
- Push the scanning head against the spacing gage and tighten the two mounting screws alternately and evenly (tightening torque = 1 Nm). The spacing gage should barely be movable.
- Check the parallelism of the scanning head to the scale tape. Push the spacing gage ca. 5 mm to the left and right between the scanning head and scale tape, checking whether the clearance is the same.
- Remove the spacing gage cautiously. If it is difficult to remove the spacing gage, loosen the scanning head and repeat the mounting procedure. Otherwise the surface of the sensor module can be damaged!

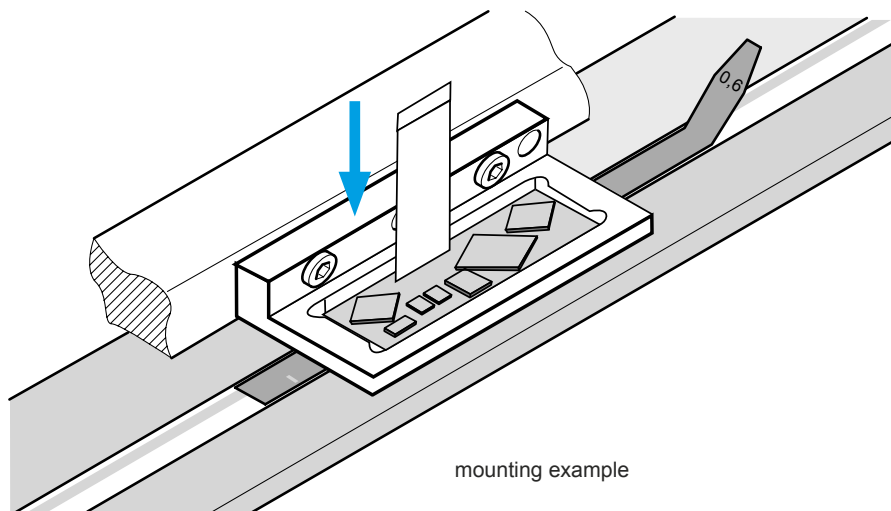

10

- Position the encoder cable including the strain relief near the scanning head.
- Connect the encoder cable to the evaluation electronics and pay attention to the pin assignment. The evaluation electronics must be switched off!
- After connecting the encoder cable switch the evaluation electronics on and test the functionality.
- If there are errors in the function or during measurement, please read chapter 12 “Troubleshooting” first. If these information are not helpful for your problem, please contact the technical support of NUMERIK JENA or an authorized representation in your country.

8. Signal Adjustment with ADJUSTMENT TOOL

Before delivery the encoders from NUMERIK JENA will be tested and electronically adjusted under ideal mounting conditions. Furthermore, the sensor modules offer the possibility of an electronic signal adjustment after the mounting into the application. This allows the user optimize the encoder signals regarding to the mechanical mounting conditions (tolerances).

The ADJUSTMENT TOOL and the related EPIFLEX software was designed to simplify and make the signal adjustment more effective.

8.1 Functions of the ADJUSTMENT TOOL

- Representation of the sinusoidal counting signals with amplitude, offset and phase position
- Representation of the position and width of the index signal
- Evaluation of the mechanical mounting conditions
- Automatic signal adjustment and programming of the sensor module
- Electronic readjustment of the amplitude and offset of the sensor signals
- Adjustment of the position and width of the index signal

8.2 Dynamic Offset and Amplitude Control (Online Compensation)

The encoders of NUMERIK JENA are equipped with a dynamic amplitude and offset control (online compensation). The analog diode signals will be corrected to their nominal values in real time. This reduces measuring errors caused by contamination as well as from inaccuracies. The phase position between the sine and cosine signals and the position of the index signal are not influenced by the online compensation.

With help of the EPIFLEX Software the preadjusted nominal values of the online compensation can be influenced.

8.3 Scope of Delivery

- ADJUSTMENT TOOL black box
- Diagnostic cable to connect the measuring system
- USB cable to connect a PC
- USB - D-SUB - adapter cable (15-pin)
- Exchangeable 8-pin plug connectors



Image 24

8.4 EPIFLEX Software

The EPIFLEX software was especially designed for the ADJUSTMENT TOOL. It offers the user versatile possibilities to bring the encoder into service. It also allows the user to display the sensor signals and evaluate them without using an oscilloscope or other expensive hardware. Furthermore it is possible to program respectively optimize the encoder to the existing mounting conditions automatically.

The EPIFLEX software is available for free via download on the NUMERIK JENA website under www.numerikjena.de. Furthermore, one can order the software with an optional USB flash drive.

The EPIFLEX software is suitable for the following operating systems:

- Windows 7 / 8 (32 or 64 bit)



Image 25

Further information about the ADJUSTMENT TOOL and the EPIFLEX software can be found on the NUMERIK JENA website.

9. Mounting Drawing - Kit L2

9.1 Scanning Head Kit L2

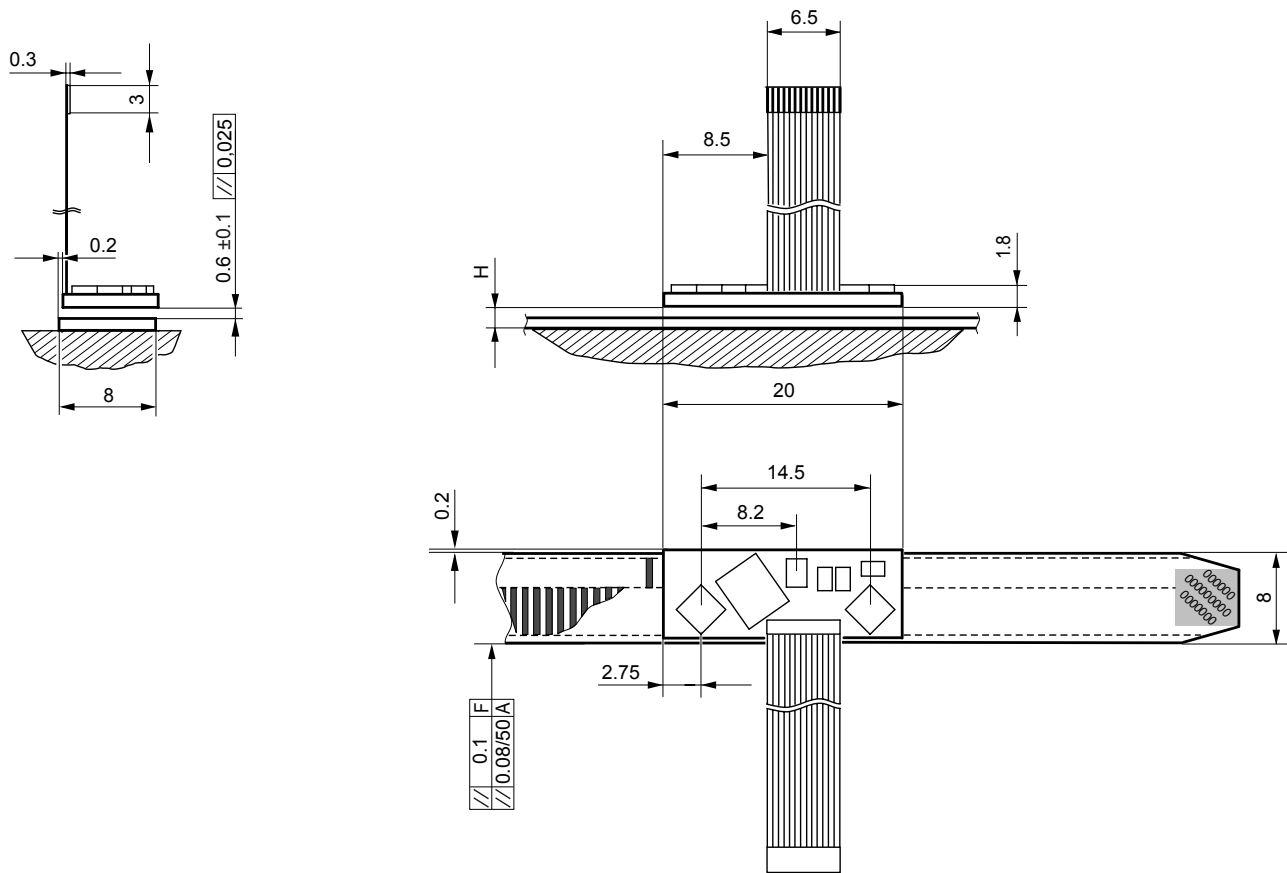

Illustration sensor without frame and SINGLEFLEX scale tape

Image 26

Scale tape	H ± 0,1
SINGLEFLEX	1,05 mm
DOUBLEFLEX	1,3 mm

F	Machine guideway
H	The mounting surface must be vertically adjustable to ensure that the distance parameter $H \pm 0.1$ and the parallelism 0.025 can be achieved

9.2 Assignment of Scanning Head, Scale Tape and Measuring Length

SINGLEFLEX and DOUBLEFLEX with fixpoint at the start of ML

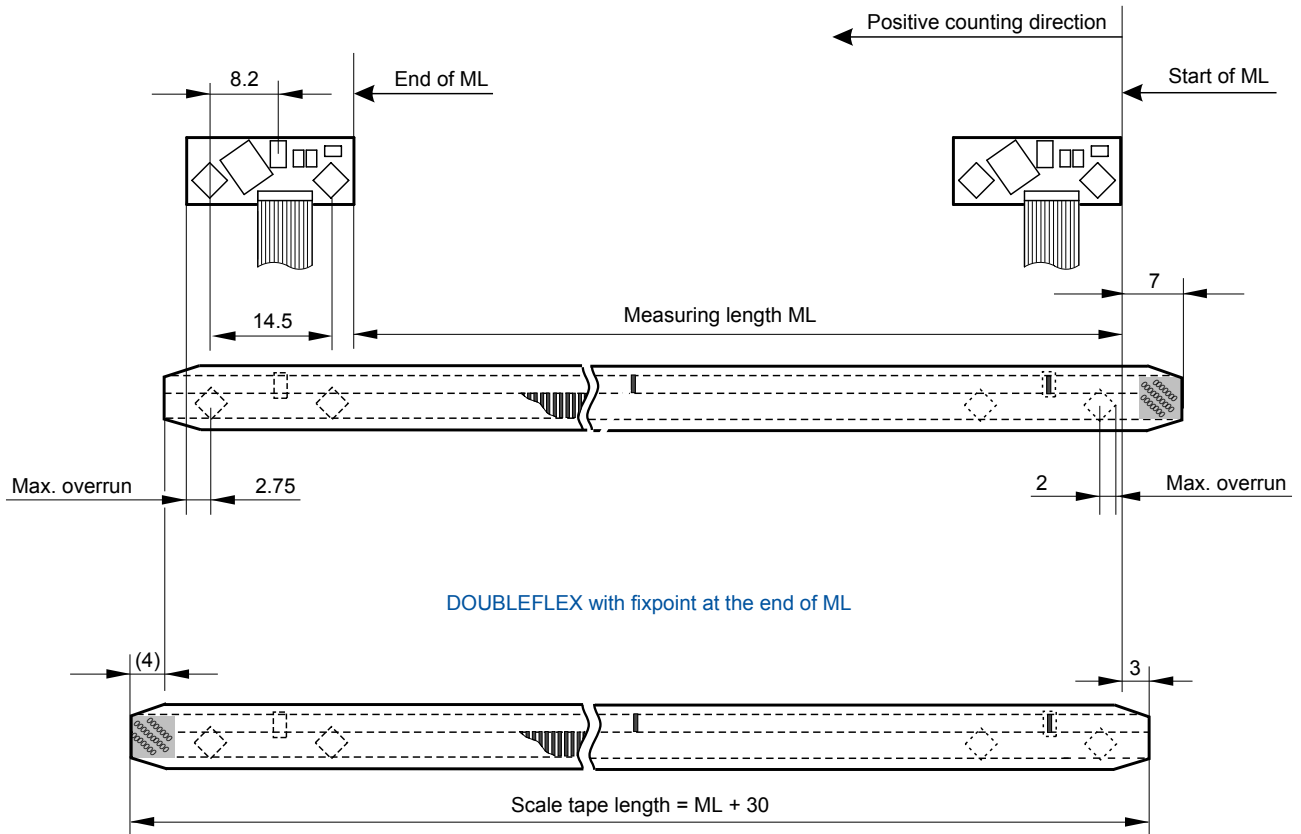

Image 27

SINGLEFLEX without name plate

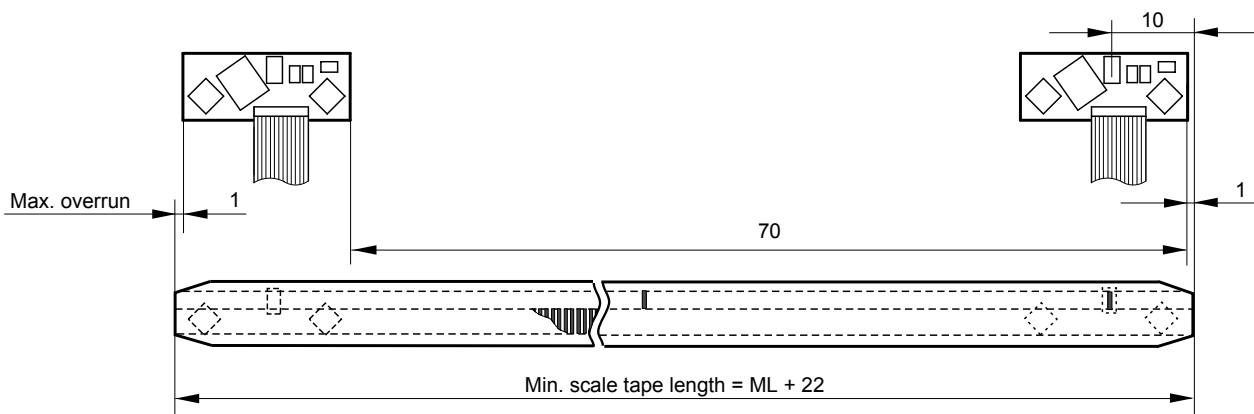

Image 28

9.3 Contour for Sensor Frame

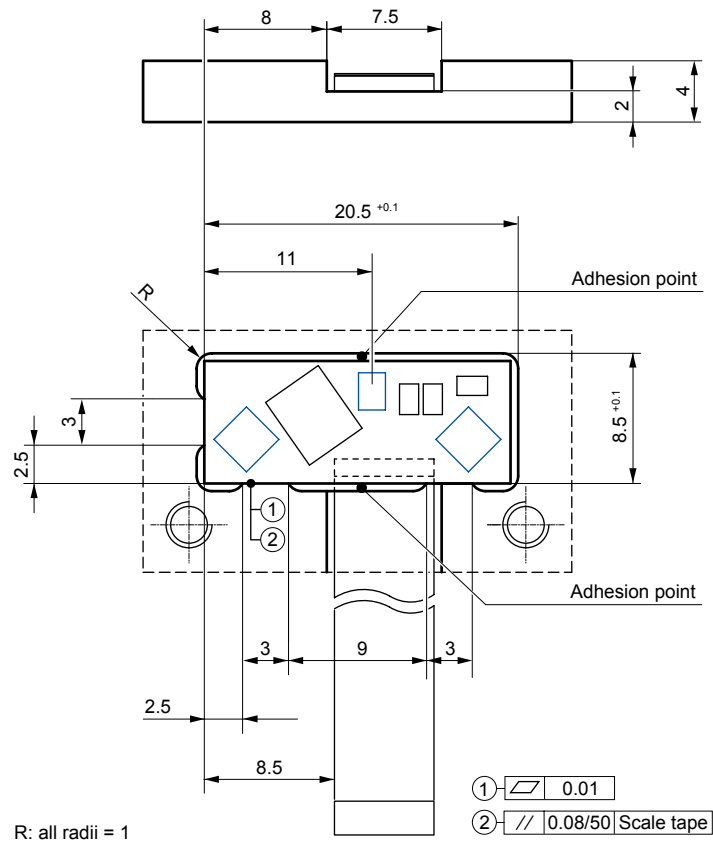

Image 29

9.4 Permissible Position Deviations - Coordinates

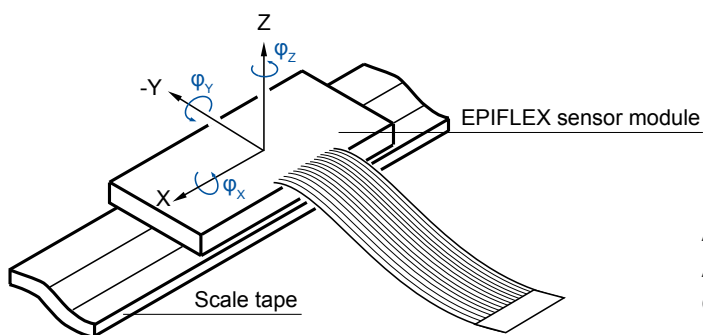

Image 30

These cumulative tolerances include mounting tolerances and guideway error during operation.

9.5 Sensor Frames - Examples

9.5.1 Frame B1 / B2

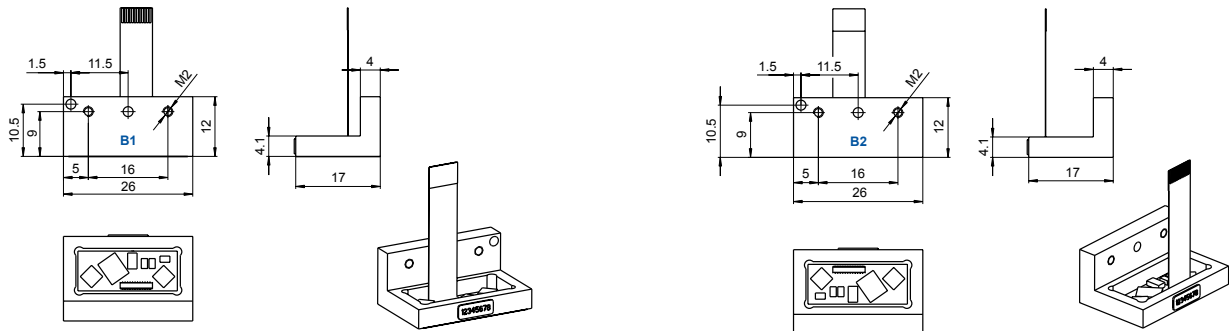

Image 31

9.5.2 Frame L2 / L3

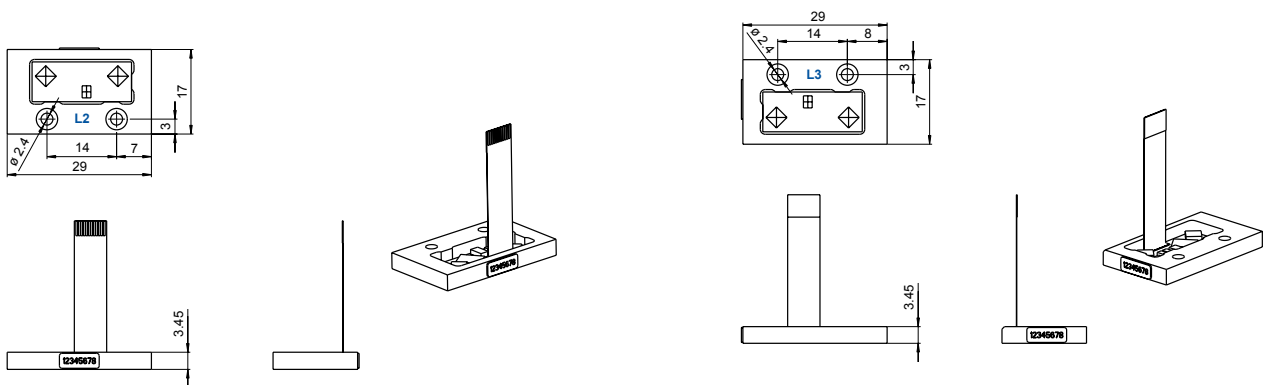

Image 32

9.5.3 Frame P4

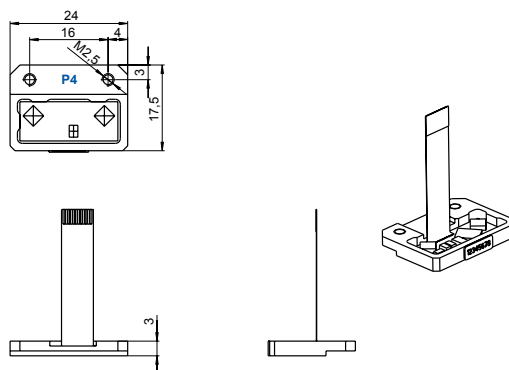

Image 33

10. Mounting Drawing - Kit L4

10.1 Scanning Head Kit L4

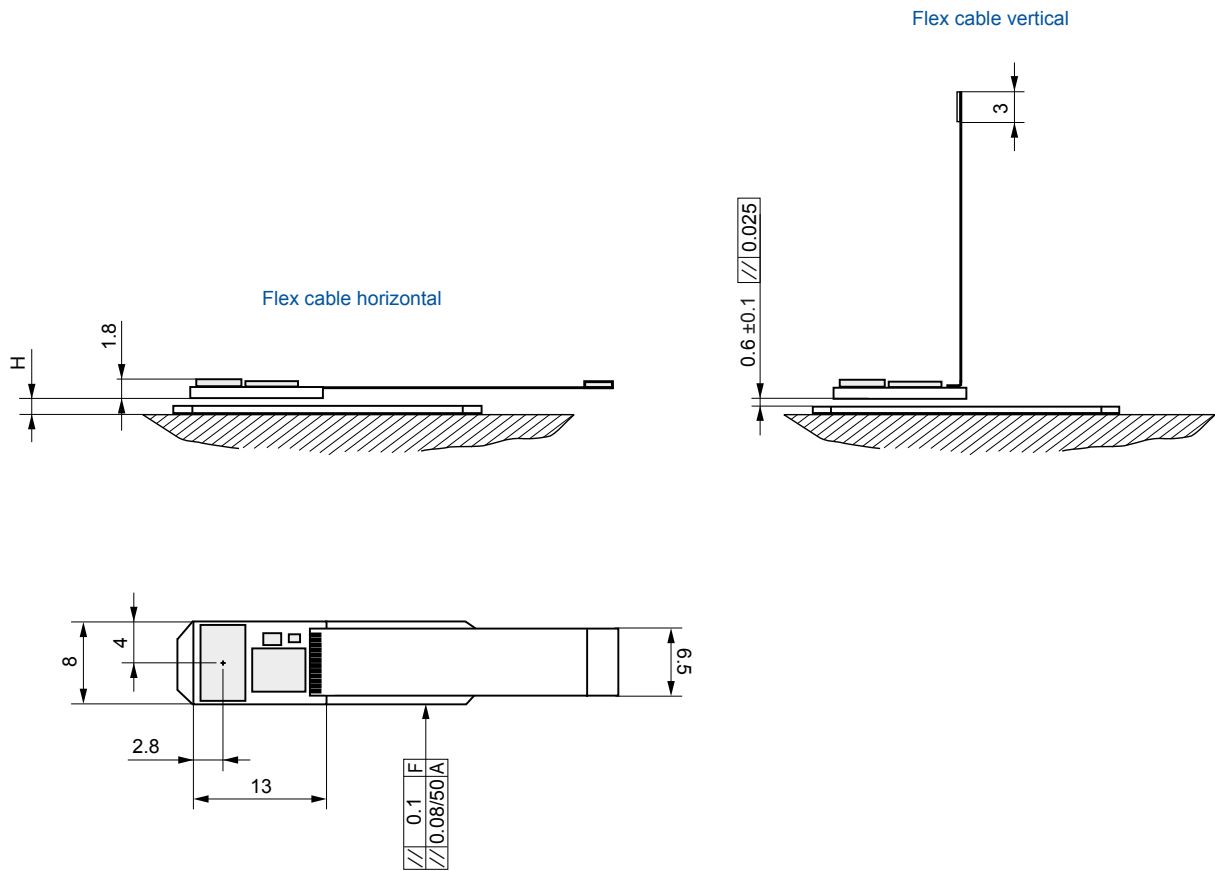

Illustration sensor without frame and SINGLEFLEX scale tape

Image 34

Scale tape	H ± 0,1
SINGLEFLEX	1,05 mm
DOUBLEFLEX	1,3 mm

F	Machine guideway
H	The mounting surface must be vertically adjustable to ensure that the distance parameter $H \pm 0.1$ and the parallelism 0.025 can be achieved

10.2 Assignment of Scanning Head, Scale Tape and Measuring Length

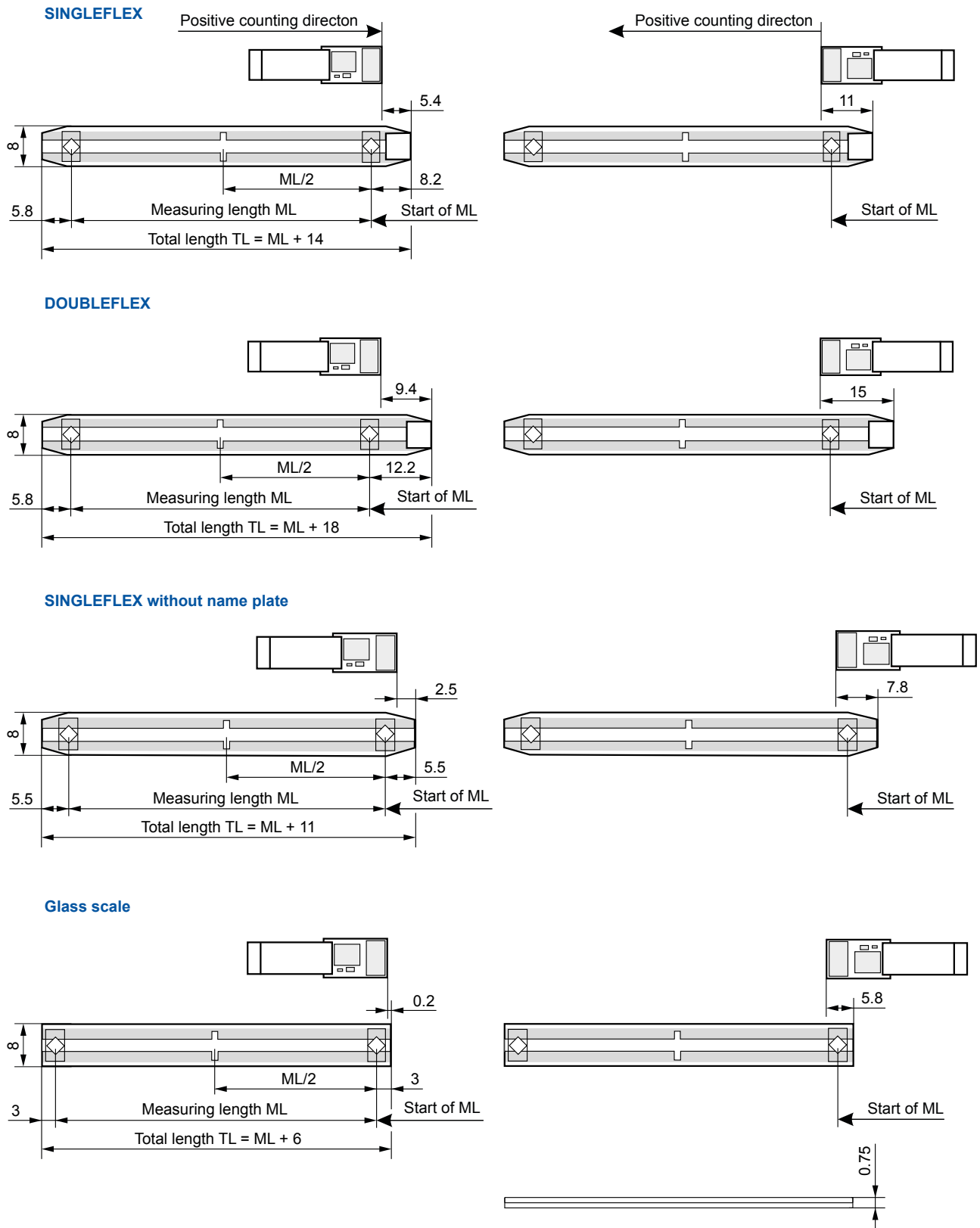
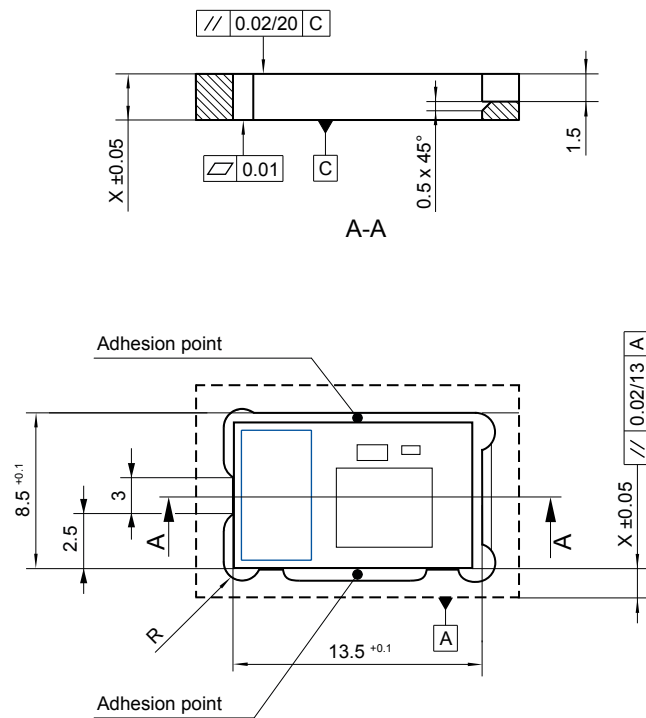

Image 35

10.3 Contour for Sensor Frame



R: all radii = 1

Image 36

10.4 Permissible Position Deviations - Coordinates

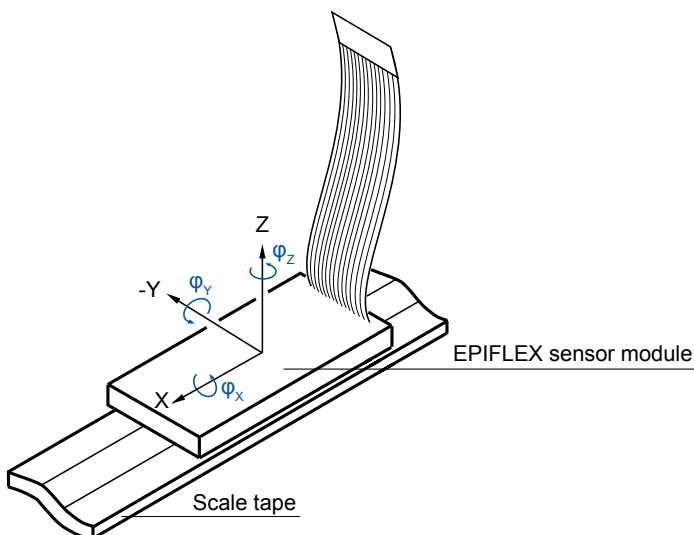

$$\begin{aligned} \Delta Z &= \pm 0.15 \text{ mm} \\ \Delta Y &= \pm 0.3 \text{ mm} \\ \varphi Z &= \pm 0.3^\circ (\pm 18') \\ \varphi Y &= \pm 0.25^\circ (\pm 15') \\ \varphi X &= \pm 2.0^\circ (\pm 120') \end{aligned}$$

These cumulative tolerances include mounting tolerances and guideway error during operation.

Image 37

10.5 Sensor Frames - Examples

10.5.1 Frame B1 / B2 / B3 / B4

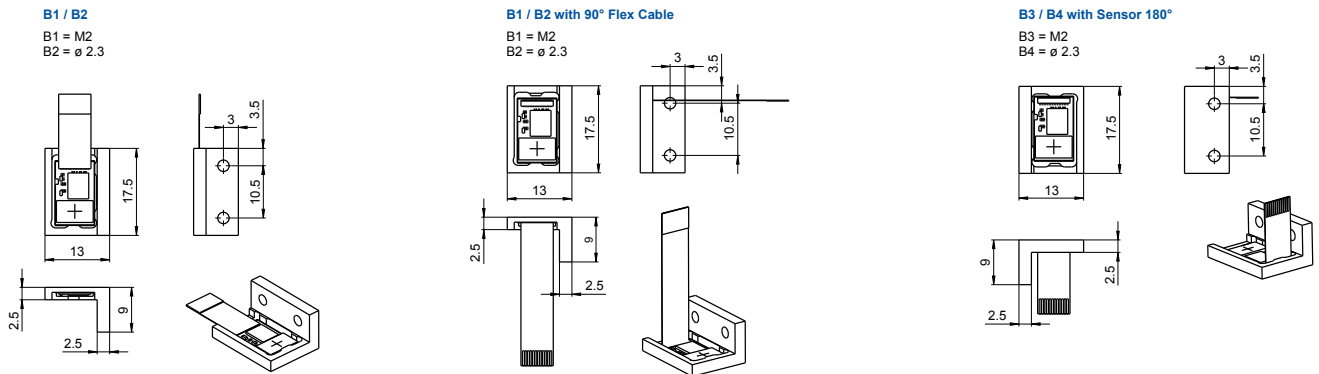

Image 38

10.5.2 Frame C1 / C2

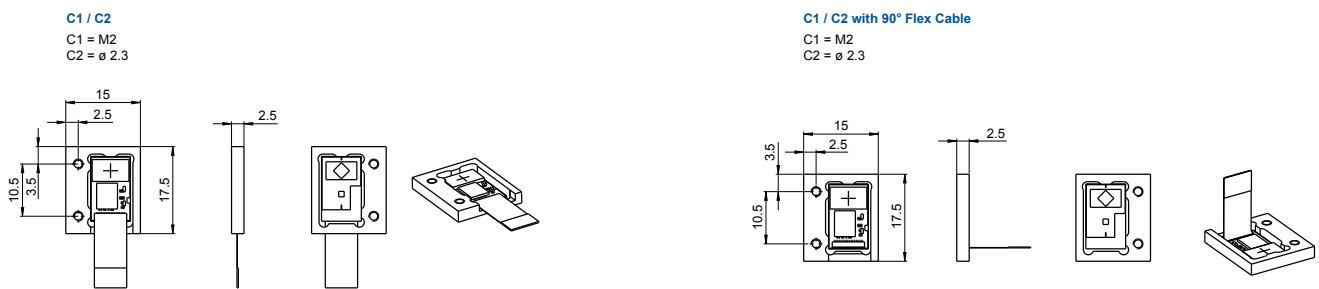

Image 39

10.5.3 Frame C6

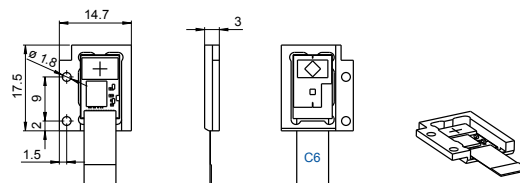

Image 40

11. Cleaning

- Depending on the measuring system's mounting attitude and the ambient conditions, it may be necessary to clean the scale tape surface and sensor surface of the scanning head (scanning window for counting and reference track) occasionally.
- If the monitoring signal output by the scanning head is used, the encoder indicates that cleaning is necessary.
- When cleaning the components, ensure that the scanning window and scale tape are not scratched by any deposited particles!
- Dirt should be removed using a soft brush or oil-free compressed air.
- Use cotton balls or a soft and lint-free rag for cleaning. Use a solvent if necessary (e.g. Acetone or Alcohol).
- Avoid to contact the solvent and the adhesive tape! This could start to dissolve the adhesive and reducing the adhesive force. Furthermore the scale tape can be detached totally.
- Please always wipe the DOUBLEFLEX scale tape lengthwise. Wiping it crosswise could result in an offset of the scale tape relative to the carrier tape and leading to errors in the function of the measuring system.
- Ensure that no solvent seeps under the scale tape! This could adversely affect the adhesive layer between the scale tape and carrier tape, thereby loosening the scale tape.

ATTENTION: Acetone and Alcohol are inflammable liquids!



12. Troubleshooting

The functions of all scanning heads and accuracy of all scale tapes are tested before the encoders are shipped. However, if troubles or problems should occur, please read the following points in the chart and proceed according to this information.

If this is not helpful, please contact the technical support of NUMERIK JENA GmbH or one of our authorized representations. You will find respective contact data on the NUMERIK JENA website www.numerikjena.de.

Error	Possible causes	Solution
No measuring signal	No power at the scanning head	<ul style="list-style-type: none"> • Check the status of the evaluation electronics • Check the connection assignment between the encoder and the evaluation electronics
Error message from the evaluation electronics	Following error due to temporary failure of the measuring signal	<ul style="list-style-type: none"> • Check the assignment of the scale tape to the scanning head • p.r.n. readjust mechanically • Readjust electronically with ADJUSTMENT TOOL*
Rough, loud motor running (for linear motors)	Irregular edge separations of the counting signals due to interpolation errors	
Counting error (compared to a standard)	Mounting error	
No reference signal	Mounting error (results in faulty gating of the reference signal and counting signal)	
Reference mark can only be detected from one direction		
Reference mark appears twice		
Not all reference marks are detected		
Failure signal reports (for RS 422)	Mounting error (results in level of the analog signal from the sensor being too low)	Clean the scale tape
	Contamination on the scale tape (results in level of the analog signal from the sensor being too low)	
	Encoder function operating error	Contact the technical support of NUMERIK JENA

Chart 8

* see also chapter 8

13. Ordering Key

13.1 Scanning Head Kit L2

Ordering key - example

Kit L	2	2	1	0	-	B	1	A	P	4	1	-	F	Z
-------	---	---	---	---	---	---	---	---	---	---	---	---	---	---

Setup of scanning head

Kit L	With signal processing
EML	Without signal processing

Type of sensor

2	2-field sensor, SV3 (20 x 8 mm)
---	---------------------------------

Grating period

2	20 μm
---	------------------

Type of flex cable

1	25 mm, vertical
2	55 mm, vertical
3	25 mm, horizontal
4	55 mm, horizontal
5	75 mm, horizontal
6	75 mm, vertical
7	95 mm, horizontal
8	95 mm, vertical

Frame - Type

A	Without frame
B	Standard frame
...	For further standard frames see page 44 (customized frames on request)

Frame - Variant

0 ... 9	Variant
---------	---------

Frame - Material

A	Aluminium
S	Steel
...	Further materials on request

Interface

C	1 V_{pp} sinus signal
K	RS 422 square-wave signal w/o interpolation
L	RS 422 square-wave signal with interpolation 5-times
M	RS 422 square-wave signal with interpolation 10-times
I	RS 422 square-wave signal with interpolation 25-times
N	RS 422 square-wave signal with interpolation 50-times
P	RS 422 square-wave signal with interpolation 100-times

Type of connector

A	10 or 14 pin JST mini. connector, female
D	9 pin D-Sub, male ¹
H	12 pin Rundstecker, male
O	15 pin D-Sub, male ¹
Z	15 pin D-Sub, male (with electronics) ¹
S	Special connector (on request)

Connector cable \varnothing 3.7 mm

(single-shielded)

R	0.3 m
S	0.5 m
T	1.0 m
P	1.5 m
V	2.0 m
W	3.0 m
U	Further lengths on request (max. 3.0 m)

Connector cable \varnothing 5.1 mm

(double-shielded)

A	0.3 m
B	0.5 m
F	1.0 m
E	1.5 m
G	2.0 m
K	3.0 m
O	Further lengths on request (max. 3.0 m)

Version

-	Standard
1	Vacuum compatible (up to 10^{-6} mbar)

Type of connector PCB

1	Type 1 (input X_1 horizontal)
2	Type 2 (input X_1 vertical)

Speed factor

X	Customer-specific value, depending on the speed of rotation and the counting frequency of the evaluation electronics (see page 53 et seq.)
---	--

¹ Straight cable outlet

13.2 Scanning Head Kit L4

Ordering key - example

Kit L 4 1 0 - P 4 2 B 1 A - F Z

Setup of scanning head

Kit L	With signal processing
EML	Without signal processing

Type of sensor

4	1-field sensor, SV3 (13 x 8 mm)
---	---------------------------------

Type of flex cable

1	25 mm, horizontal
2	55 mm, horizontal
3	25 mm, vertical
4	55 mm, vertical
5	75 mm, horizontal
6	75 mm, vertical
7	95 mm, horizontal
8	95 mm, vertical

Grating period

-	20 μm
---	------------------

Interface

C	1 V_{pp} sinus signal
K	RS 422 square-wave signal w/o interpolation
L	RS 422 square-wave signal, interpolation 5-times
M	RS 422 square-wave signal, interpolation 10-times
I	RS 422 square-wave signal, interpolation 25-times
N	RS 422 square-wave signal, interpolation 50-times
P	RS 422 square-wave signal, interpolation 100-times

Speed factor

X	Customer-specific value, depending on the speed of rotation and the counting frequency of the evaluation electronics (see page 53 et seq.)
---	--

Type of connector PCB

1	Type 1 (input X_1 horizontal)
2	Type 2 (input X_1 vertical)

Type of frame

A	Without frame
B	Standard frame
...	For further standard frames see page 48 (customized frames on request)

Type of connector

A	10 or 14 pin JST mini. connector, female
D	9 pin D-Sub, male ¹
H	12 pin Rundstecker, male
O	15 pin D-Sub, male ¹
Z	15 pin D-Sub, male (with electronics) ¹
S	Special connector (on request)

Connector cable \varnothing 3.7 mm

(single-shielded)

R	0.3 m
S	0.5 m
T	1.0 m
P	1.5 m
V	2.0 m
W	3.0 m
U	Further lengths on request (max. 3.0 m)

Connector cable \varnothing 5.1 mm

(double-shielded)

A	0.3 m
B	0.5 m
F	1.0 m
E	1.5 m
G	2.0 m
K	3.0 m
O	Further lengths on request (max. 3.0 m)

Version

-	Standard
1	Vacuum compatible (up to 10^{-6} mbar)

Frame - Material

A	Aluminium
S	Steel
...	Further materials on request

Frame - Variant

0 ... 9	Variant
---------	---------

¹ Straight cable outlet

13.3 Speed Chart for LIK Series

13.3.1 LIK Series with Op-Amp

The maximum attainable traversing speed of the encoder is determined by the maximum output frequency of the interpolator and/or the maximum counting frequency of the operator's evaluation electronics (e.g. controller or display).

Please take the suitable values for your application from the following charts and enter it into the corresponding place (for "X") in the ordering key. Pay attention to your chosen interpolation factor and the targeted traversing speed first. If you have found the respective information, please check if your evaluation electronics is able to achieve the needed counting frequency.

The maximum scanning frequency of the encoder amounts to 200 kHz standardly, hence the maximum attainable traversing speed will be derived from that. The op-amp decouples parasitic frequencies and improves the interference immunity of the encoder under unfavorable conditions. The encoders from NUMERIK JENA are available without op-amp also. Thus it is possible to increase the scanning frequency which consequently enables higher traversing speeds up to 10 m/s.

C Without interpolation factor

Value for X	Max. traversing speed (in m/s)	Max. scanning frequency of the measuring system (in kHz)	Min. counting frequency of the evaluation electronics without 4-edge evaluation (in MHz)	Min. counting frequency of the evaluation electronics with 4-edge evaluation (in MHz)
0	4.00	200	0.75	3

L Interpolation factor = 5

Value for X	Max. traversing speed (in m/s)	Max. scanning frequency of the measuring system (in kHz)	Min. counting frequency of the evaluation electronics without 4-edge evaluation (in MHz)	Min. counting frequency of the evaluation electronics with 4-edge evaluation (in MHz)
1	0.67	33	0.25	1
2	1.33	67	0.50	2
Y	2.00	100	0.75	3
3	2.67	133	1.00	4
Z	4.00	200	1.50	6

M Interpolation factor = 10

Value for X	Max. traversing speed (in m/s)	Max. scanning frequency of the measuring system (in kHz)	Min. counting frequency of the evaluation electronics without 4-edge evaluation (in MHz)	Min. counting frequency of the evaluation electronics with 4-edge evaluation (in MHz)
1	0.33	17	0.25	1
2	0.67	33	0.50	2
Y	1.00	50	0.75	3
3	1.33	67	1.00	4
Z	2.00	100	1.50	6
4	2.67	133	2.00	8
5	4.00	200	3.00	12

The listed values in the charts refer to a grating period (TP) of 20 µm.

I Interpolation factor = 25

Value for X	Max. traversing speed (in m/s)	Max. scanning frequency of the measuring system (in kHz)	Min. counting frequency of the evaluation electronics without 4-edge evaluation (in MHz)	Min. counting frequency of the evaluation electronics with 4-edge evaluation (in MHz)
1	0.13	7	0.25	1
2	0.27	13	0.50	2
Y	0.40	20	0.75	3
3	0.53	27	1.00	4
Z	0.80	40	1.50	6
4	1.07	53	2.00	8
5	1.60	80	3.00	12
6	2.13	107	4.00	16
7	2.67	133	5.00	20
8	3.20	160	6.00	24

N Interpolation factor = 50

Value for X	Max. traversing speed (in m/s)	Max. scanning frequency of the measuring system (in kHz)	Min. counting frequency of the evaluation electronics without 4-edge evaluation (in MHz)	Min. counting frequency of the evaluation electronics with 4-edge evaluation (in MHz)
1	0.07	3	0.25	1
2	0.13	7	0.50	2
Y	0.20	10	0.75	3
3	0.27	13	1.00	4
Z	0.40	20	1.50	6
4	0.53	27	2.00	8
5	0.80	40	3.00	12
6	1.07	53	4.00	16
7	1.33	67	5.00	20
8	1.60	80	6.00	24

P Interpolation factor = 100

Value for X	Max. traversing speed (in m/s)	Max. scanning frequency of the measuring system (in kHz)	Min. counting frequency of the evaluation electronics without 4-edge evaluation (in MHz)	Min. counting frequency of the evaluation electronics with 4-edge evaluation (in MHz)
1	0.03	2	0.25	1
2	0.07	3	0.50	2
Y	0.10	5	0.75	3
3	0.13	7	1.00	4
Z	0.20	10	1.50	6
4	0.27	13	2.00	8
5	0.40	20	3.00	12
6	0.53	27	4.00	16
7	0.67	33	5.00	20
8	0.80	40	6.00	24

The listed values in the charts refer to a grating period (TP) of 20 µm.

13.3.2 LIK Series without Op-Amp

The maximum scanning frequency of the encoder without op-amp amounts to 500 kHz, hence the maximum attainable traversing speed will be derived from that. This enables traversing speeds up to 10 m/s.

C (1 VSS) or **K** (RS 422) Without interpolation factor

Value for X	Max. traversing speed (in m/s)	Max. scanning frequency of the measuring system (in kHz)	Min. counting frequency of the evaluation electronics without 4-edge evaluation (in MHz)	Min. counting frequency of the evaluation electronics with 4-edge evaluation (in MHz)
for C : A	10.00	500	0,75	3
for K : 0				

L Interpolation factor = 5

Value for X	Max. traversing speed (in m/s)	Max. scanning frequency of the measuring system (in kHz)	Min. counting frequency of the evaluation electronics without 4-edge evaluation (in MHz)	Min. counting frequency of the evaluation electronics with 4-edge evaluation (in MHz)
B	0.67	33	0.25	1
C	1.33	67	0.50	2
D	2.00	100	0.75	3
E	2.67	133	1.00	4
G	4.00	200	1.50	6
4	5.33	267	2.00	8
5	8.00	400	3.00	12
6	10.00	500	4.00	16

M Interpolation factor = 10

Value for X	Max. traversing speed (in m/s)	Max. scanning frequency of the measuring system (in kHz)	Min. counting frequency of the evaluation electronics without 4-edge evaluation (in MHz)	Min. counting frequency of the evaluation electronics with 4-edge evaluation (in MHz)
B	0.33	17	0.25	1
C	0.67	33	0.50	2
D	1.00	50	0.75	3
E	1.33	67	1.00	4
G	2.00	100	1.50	6
R	2.67	133	2.00	8
S	4.00	200	3.00	12
6	5.33	267	4.00	16
7	6.67	333	5.00	20
8	8.00	400	6.00	24

The listed values in the charts refer to a grating period (TP) of 20 µm.

I Interpolation factor = 25

Value for X	Max. traversing speed (in m/s)	Max. scanning frequency of the measuring system (in kHz)	Min. counting frequency of the evaluation electronics without 4-edge evaluation (in MHz)	Min. counting frequency of the evaluation electronics with 4-edge evaluation (in MHz)
B	0.13	7	0.25	1
C	0.27	13	0.50	2
D	0.40	20	0.75	3
E	0.53	27	1.00	4
G	0.80	40	1.50	6
R	1.07	53	2.00	8
S	1.60	80	3.00	12
T	2.13	107	4.00	16
U	2.67	133	5.00	20
V	3.20	160	6.00	24

N Interpolation factor = 50

Value for X	Max. traversing speed (in m/s)	Max. scanning frequency of the measuring system (in kHz)	Min. counting frequency of the evaluation electronics without 4-edge evaluation (in MHz)	Min. counting frequency of the evaluation electronics with 4-edge evaluation (in MHz)
B	0.07	3	0.25	1
C	0.13	7	0.50	2
D	0.20	10	0.75	3
E	0.27	13	1.00	4
G	0.40	20	1.50	6
R	0.53	27	2.00	8
S	0.80	40	3.00	12
T	1.07	53	4.00	16
U	1.33	67	5.00	20
V	1.60	80	6.00	24

P Interpolation factor = 100

Value for X	Max. traversing speed (in m/s)	Max. scanning frequency of the measuring system (in kHz)	Min. counting frequency of the evaluation electronics without 4-edge evaluation (in MHz)	Min. counting frequency of the evaluation electronics with 4-edge evaluation (in MHz)
B	0.03	2	0.25	1
C	0.07	3	0.50	2
D	0.10	5	0.75	3
E	0.13	7	1.00	4
G	0.20	10	1.50	6
R	0.27	13	2.00	8
S	0.40	20	3.00	12
T	0.53	27	4.00	16
U	0.67	33	5.00	20
V	0.80	40	6.00	24

The listed values in the charts refer to a grating period (TP) of 20 µm.

13.4 Scale Tape MV

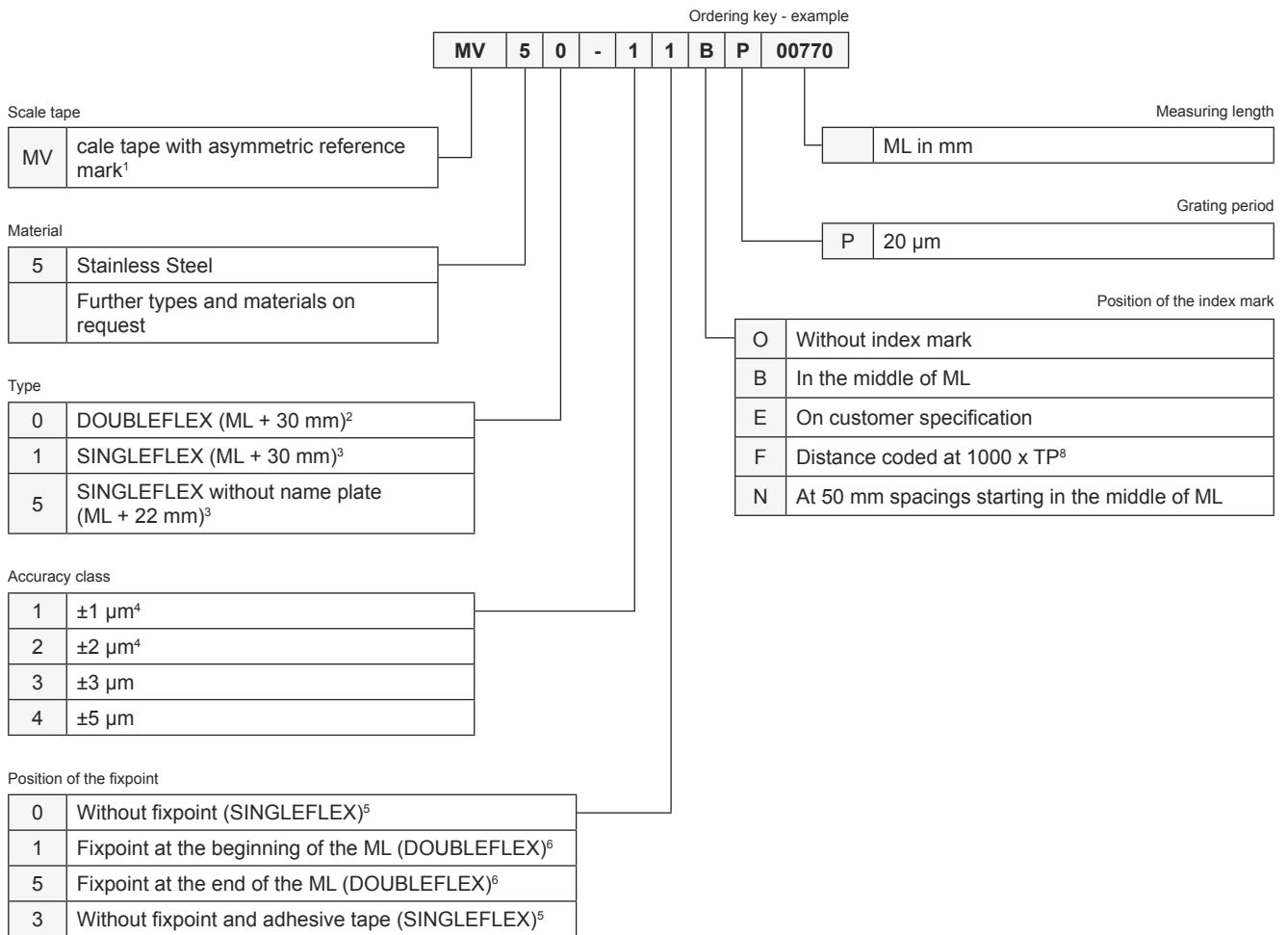

¹ This type is suitable for Kit L2 encoders

² DOUBLEFLEX min. ML = 100 mm; max. ML = 5,000 mm

³ SINGLEFLEX max. ML = 30,000 mm

⁴ Max. ML = 500 mm

⁵ Only for SINGLEFLEX scale tape

⁶ Only for DOUBLEFLEX scale tape

⁸ SINGLEFLEX max. ML = 8,750 mm / DOUBLEFLEX max. ML = 5,000 mm

ML - Measuring length

TP - Grating period

13.5 Scale Tape MT

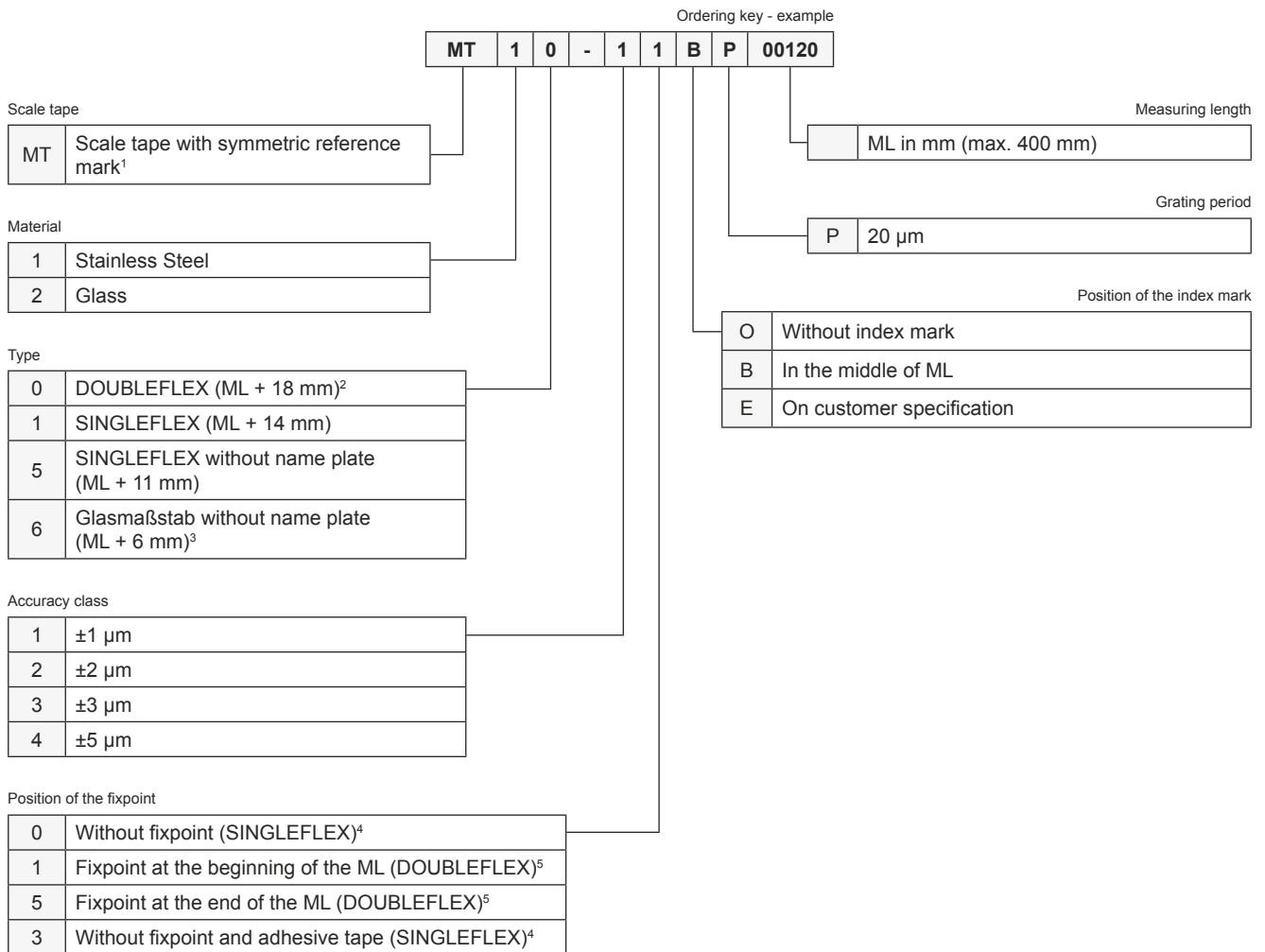

¹ This type is suitable for Kit L4 encoders

² Min. ML = 100 mm; max. ML = 400 mm

³ Only in combination with accuracy class ±1 µm

⁴ Only for SINGLEFLEX scale tape

⁵ Only for DOUBLEFLEX scale tape

ML - Measuring length

13.6 ADJUSTMENT TOOL

Name	Scope of delivery / Description	Order-no.
ADJUSTMENT TOOL	<ul style="list-style-type: none"> • ADJUSTMENT TOOL black box • Diagnostic cable to connect the measuring system • USB cable to connect a PC • USB - D-SUB - adapter cable (15-pin) • Exchangeable 8-pin plug connectors 	344220-33

Optional Single Components

Name	Description	Order-no.
EPIFLEX software - USB flash drive	External flash drive with saved EPIFLEX software	686802-02
USB - D-SUB - adapter cable (15-pin)	to supply the measuring system with voltage via PC	341693-0M
8-pin plug connector	to connect the diagnostic cable to the diagnostic socket	348958-01



USB - D-SUB - adapter cable (15-pin)

Image 41

Required components (not included):

- PC with OS Windows 7 / 8 (32 or 64 bit)



NUMERIK JENA GmbH

Im Semmicht 4
07751 Jena
Germany

Phone: +49 3641 4728-0

Fax: +49 3641 4728-202

E-Mail: info@numerikjena.de
www.numerikjena.de



Version 08 2016

Subject to change without prior notice.

© & © NUMERIK JENA GmbH