

# Squeezer in-vacuum translation stage

---

John Miller

LIGO Laboratory

MIT

# Uses

- OPO cavity (HAM6) is resonant at two wavelengths. Stage compensates for refractive index change on moving to vacuum (infrequent use)

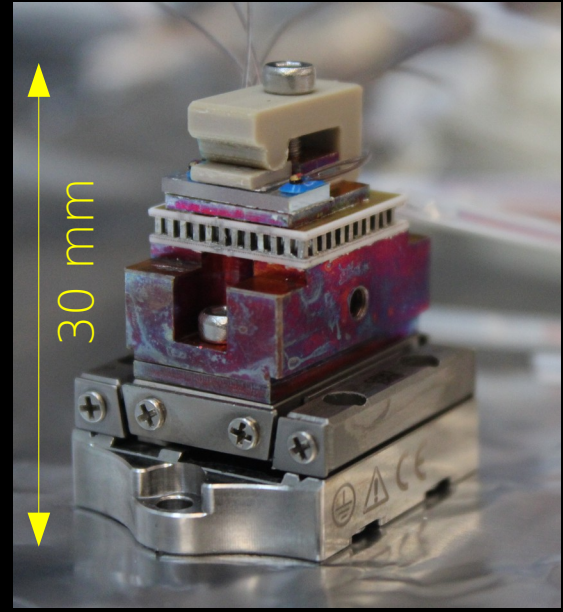
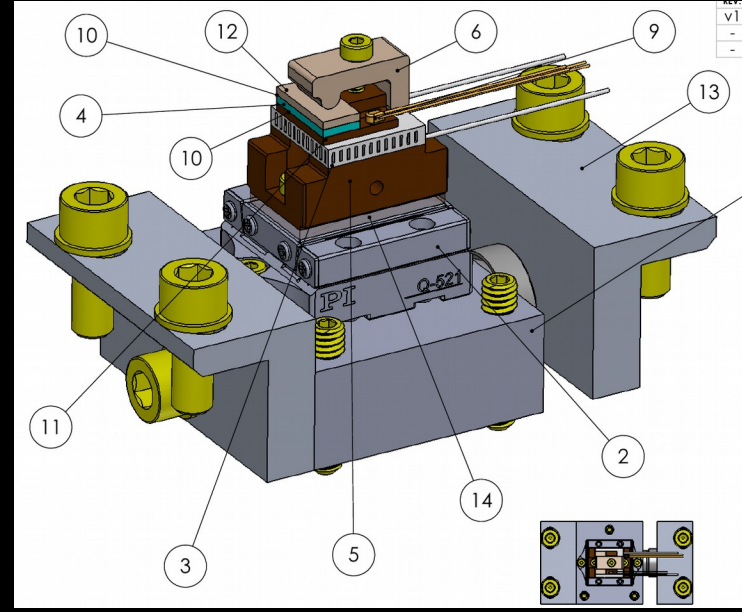
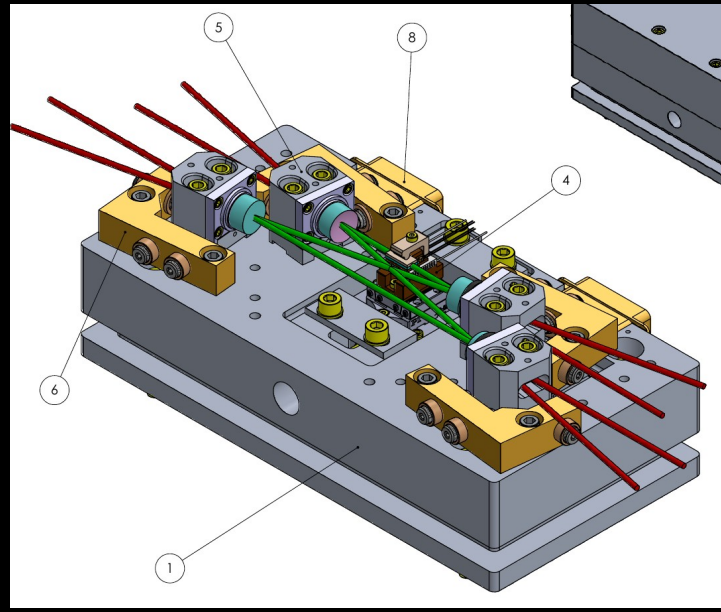

- Remote mode matching of squeezing to filter cavity and IFO (possibly elsewhere)

# PI Q-521

---

- See [D1500086](#)
- Small, light, closed-loop. Works via stick-slip piezo drive (see [YouTube](#))



- Marketed as suitable for  $1e-9$  mbar, shipped double-bagged etc. but contains non-approved materials
- Lubricant, three adhesives, PTFE wiring



# Disassembly - top

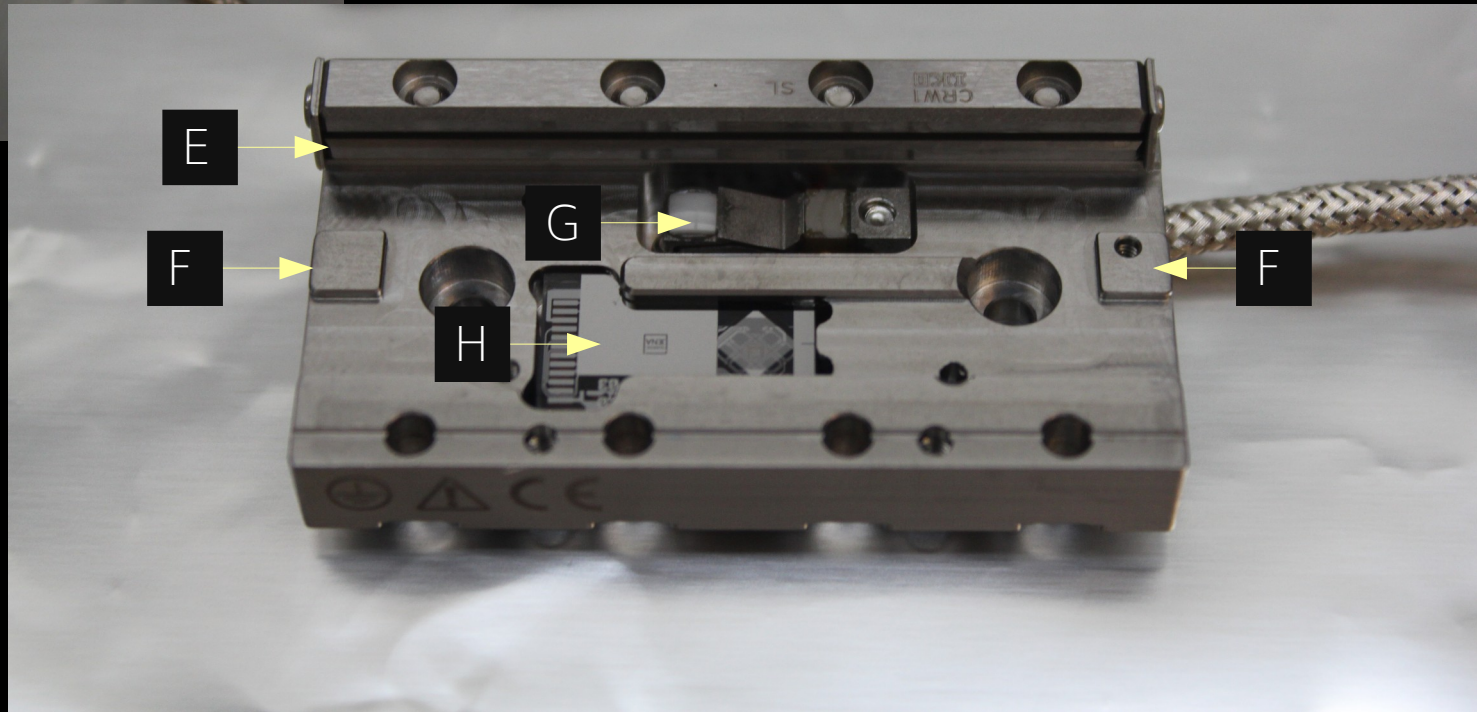
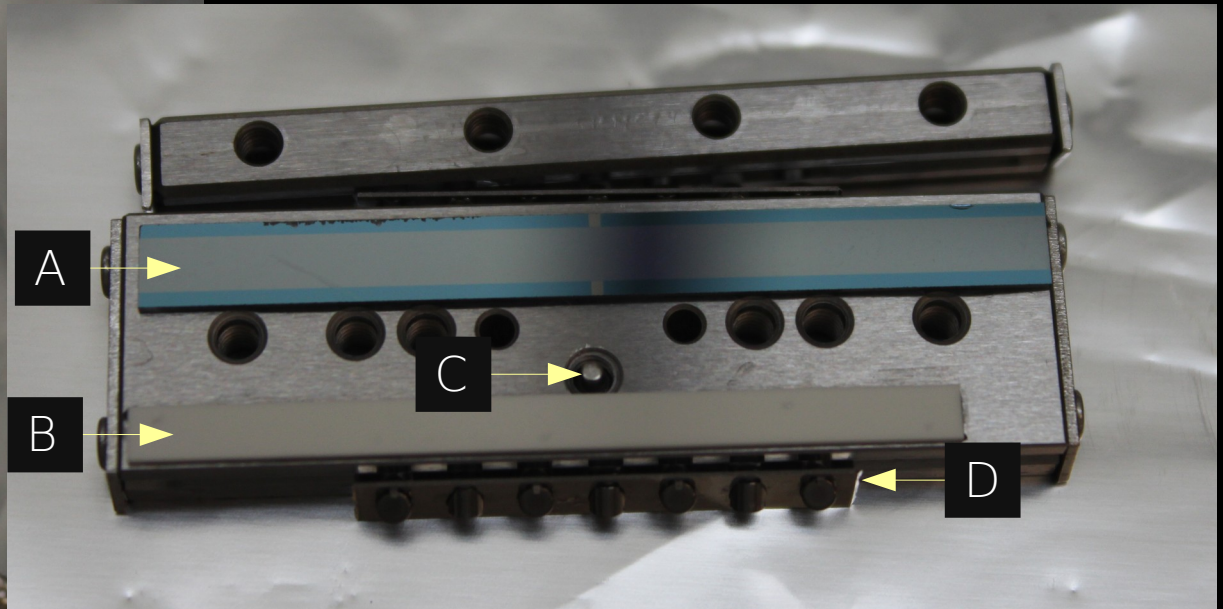
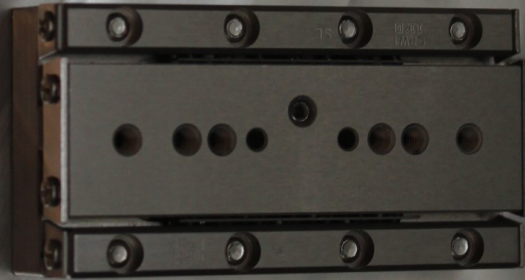



# Disassembly - bottom

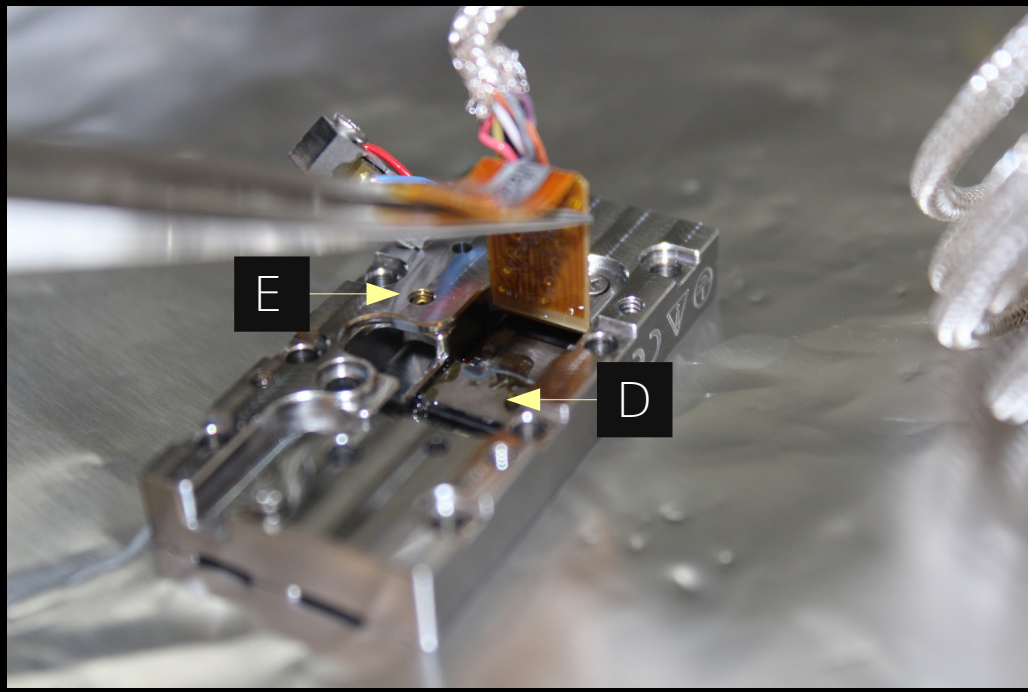
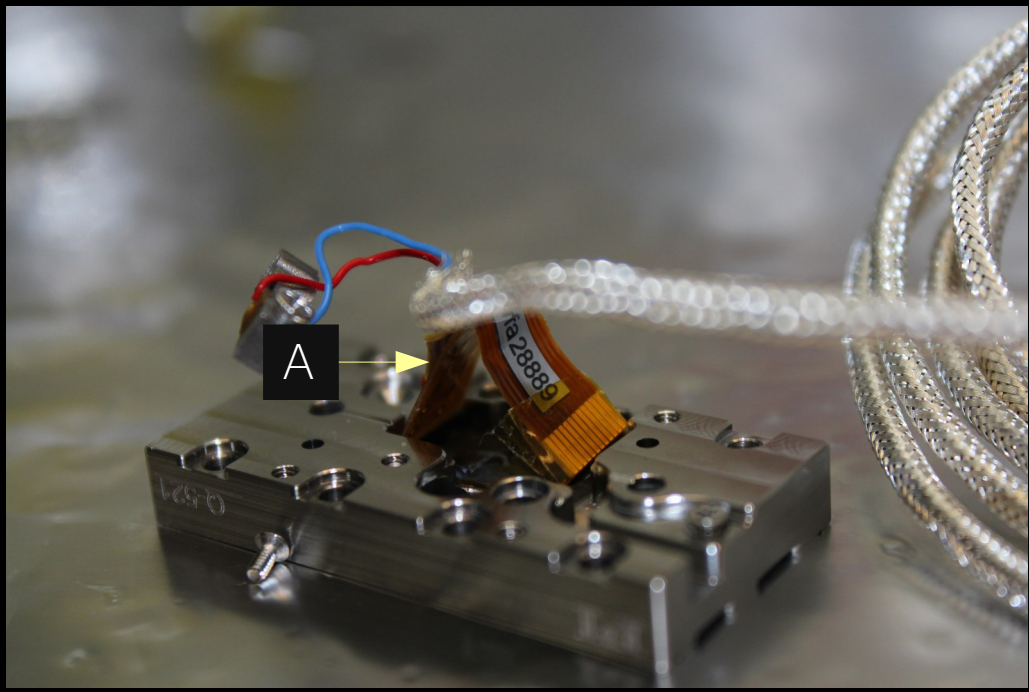
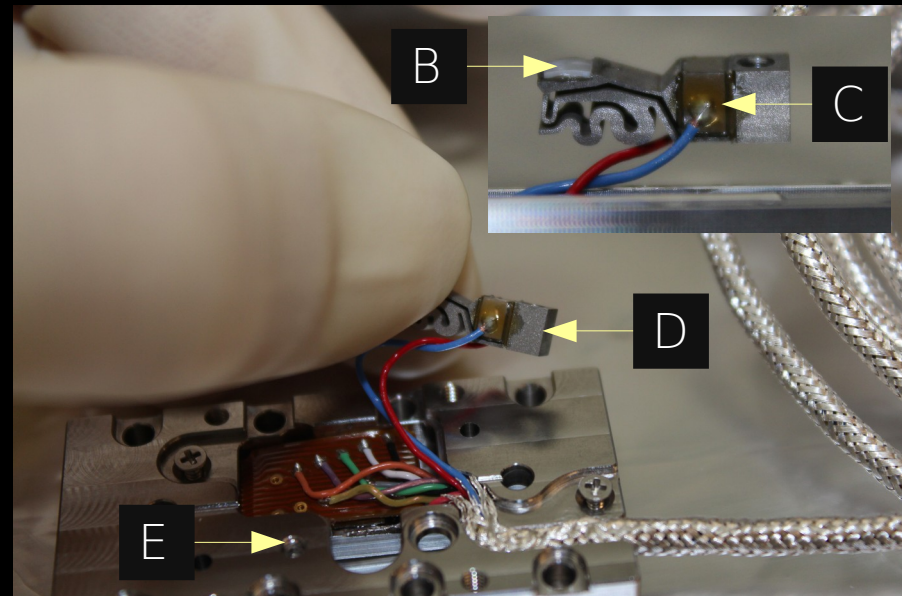
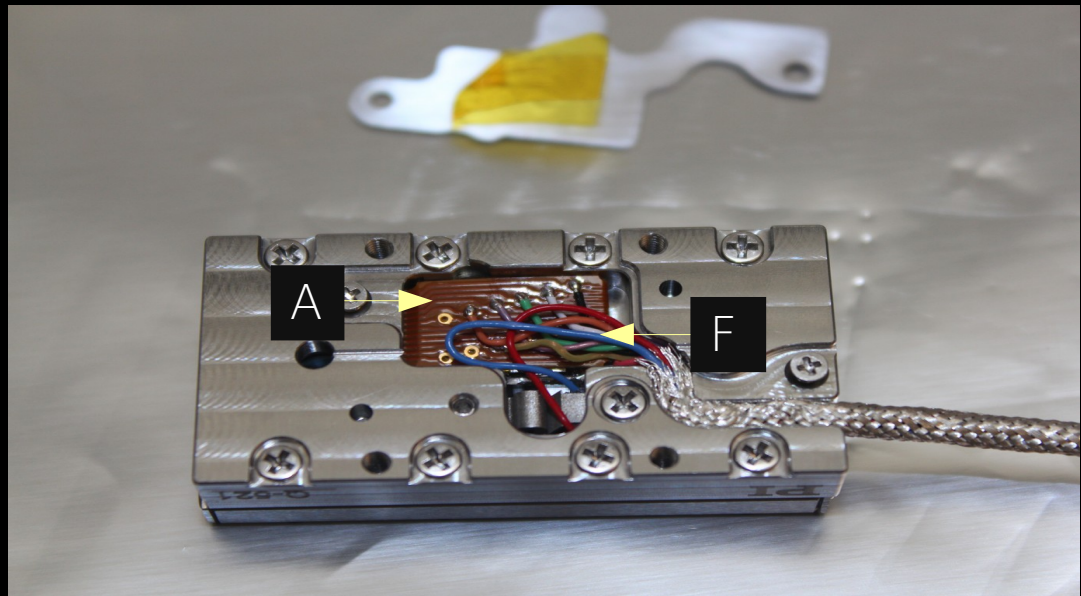

# Other options

---

- Newport [9066-COM-V](#)
  - Requires redesign of OPO cavity
  - Larger, heavier (balancing?)
  - Materials look good (Krytox grease)
  - Cheaper
  - Utilises piezomotor drive (existing infrastructure)
- Newport Agilis [AG-LS25V6](#)
  - Small
  - Minimal redesign of cavity (to be checked)
  - Cheaper
  - Unknown materials, marketed as good to  $1e-6$  mbar



# 9066 materials

Component	Material Description
PA004071	STAGE,1/2 IN X ROLL TRANS, VAC
P2102214	PLATE,BOTTOM,1/2 IN STAGE, VAC
003810	PAD, CARBIDE, .095 DIA X .031
B01-00016	EPOXY,3M-2216
B08-00008	PRESOLVE CLEANER/DEGREASER, LPS
P2102215	RAIL,LINEAR,1/2 IN STAGE, VAC
P2102557	PIN, 1/16 X 3/16,SPRING, SST
P2102558	PIN, 1/16 X 1/4,SPRING,SST
M05-00016	SPRING, EXT .120 X .604
002319	GREASE, KRYTOX, LVP (HIGH VACUUM)
P2102074	PLATE, TOP , 1/2 IN STAGE, VAC
M08-00070	SCREW, 3-48 X 1/4, SHCS
M03-00013	BEARING, RACE,CROSS ROLLER, 1/2 IN
001002	SCREW, 2-56 X 3/8 SHCS
P2102216	CLAMP,MICROMETER,1/2 IN STAGE, VAC
003869	SCREW, 3-48 X 5/8 SHCS
M10-00027	WASHER, .147 OD, .100 ID, .010 THK
004040	SCREW, SET, 2-56 X 5/32 SSVS
P2102213	PLATE,LOCK,1/2 IN STAGE, VAC
P2102212	COVER PLATE,LOCK,1/2 IN STAGE, VAC
M10-00006	WASHER, #2, .089 X .188 X .024, SST
B05-00051	ALUMINUM FOIL, UHV, .0015 THK X 18 IN
P2102613	SCREW, 2-56 X 5/32 SHCS
B04-00013	DESICCANT,DESI PAC,16X33 MM
B04-00007	BAG,CLASS 100,5X7,MDPE-3MIL
004268	PIN, DOWEL, 1/8 X 1/4
001050	SCREW, 4-40 X 3/8 SHCS
B04-00006	BOX,SHIPPING,8X8X6,WHT,B-FLUTE 200#
906806	MANUAL,USERS,#9066,#9067
906805	FOAM SET,2 PC,PKG,DIE CUT,#9066
900004	LABEL,PACKAGING,MODEL/SERIAL/LOT #
RT0214	ARTWORK,LABEL,PACKAGING
B03-00014	LABEL,ROHS COMPLIANT



# 9066 integration (Fabrice)

