

# LASER INTERFEROMETER GRAVITATIONAL WAVE OBSERVATORY

**-LIGO-**

**CALIFORNIA INSTITUTE OF TECHNOLOGY**

**MASSACHUSETTS INSTITUTE OF TECHNOLOGY**

Document Type	DCC Number	Jan 13 <sup>th</sup> , 2015
Test Procedure	T1500008-v2	
<b>Capacitive Position Sensor Timing Fanout Test Procedure</b>		
B. Abbott		

Distribution of this draft:  
This is an internal working note of the LIGO Laboratory

**California Institute of Technology**  
**LIGO Project – MS 18-33**  
**Pasadena, CA 91125**  
Phone (626) 395-2129  
Fax (626) 304-9834  
E-mail: info@ligo.caltech.edu

**Massachusetts Institute of Technology**  
**LIGO Project – MS 20B-145**  
**Cambridge, MA 01239**  
Phone (617) 253-4824  
Fax (617) 253-7014  
E-mail: info@ligo.mit.edu

<http://www.ligo.caltech.edu/>

Performed by: \_\_\_\_\_  
 Date: \_\_\_\_\_  
 Chassis Serial Number: \_\_\_\_\_  
 Power Board Serial Number: \_\_\_\_\_  
 Main Board Serial Number: \_\_\_\_\_

**1. Overview**

The Capacitive Position Sensor Timing Fanout Chassis is designed to accept a 71MHz input timing sine wave, of 8dBm to 18dBm, and turn it into 6 sets of square timing pulses, each with a differential 1.543MHz square wave, and a 25.725 KHz synch pulse. These signals are sent via RS485 transmitters to receivers on the CPS Voltage Regulator boards. This document will describe how to test each chassis, to ensure proper functionality.

**2. Test Equipment**

- 2.1 Power Supply capable of +18V.
- 2.2 Signal generator capable of supplying at least an 8dBm level 71MHz signal.
- 2.3 Oscilloscope.

**3. Preliminaries**

- 3.1 Perform visual inspection on board to check for missing components or solder deficiencies
- 3.2 Before connecting the power to the chassis, set power supply to +18 Volts, then turn off. Connect the power supply to the chassis under test at the back panel 3-pin power connector labeled "Power".

**4. DC Tests**

4.1 Connect the 71MHz signal to the front panel BNC labeled "71MHz Clock In", and turn on the power supplies to the system under test. Turn on the chassis power switch and record the total current.

Measure	Current	Current correct?
+18V Supply	140mA +/- 20mA	

4.2 Visually verify that the following LEDs are illuminated correctly:

LED	Expected Output	Function Correct?
“Board Power” +12V	Constant, bright green	
“Board Power” +5V	Constant, bright green	
“1PPS Heartbeat”	Binking, bright green, 1Hz frequency	

## 5. Signal Generation Tests

There are 6 output DSub connectors on the front panel labeled “Synch Out” 1-6. Each of them should have a pair of differential signals coming from it: a 1.543MHz square wave, and a 25.725 KHz synch pulse. The pinout is shown below:

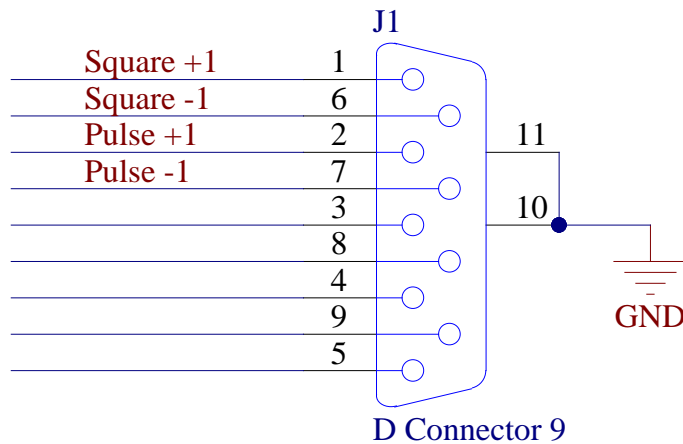

Use two channels of your oscilloscope, and set the math to display CH1-CH2. Connect the GNDs of the scope together, and ground them to the chassis. Connect the signal side to the pins below, and compare them to the expected waveforms.

Pins 1&6 waveform:

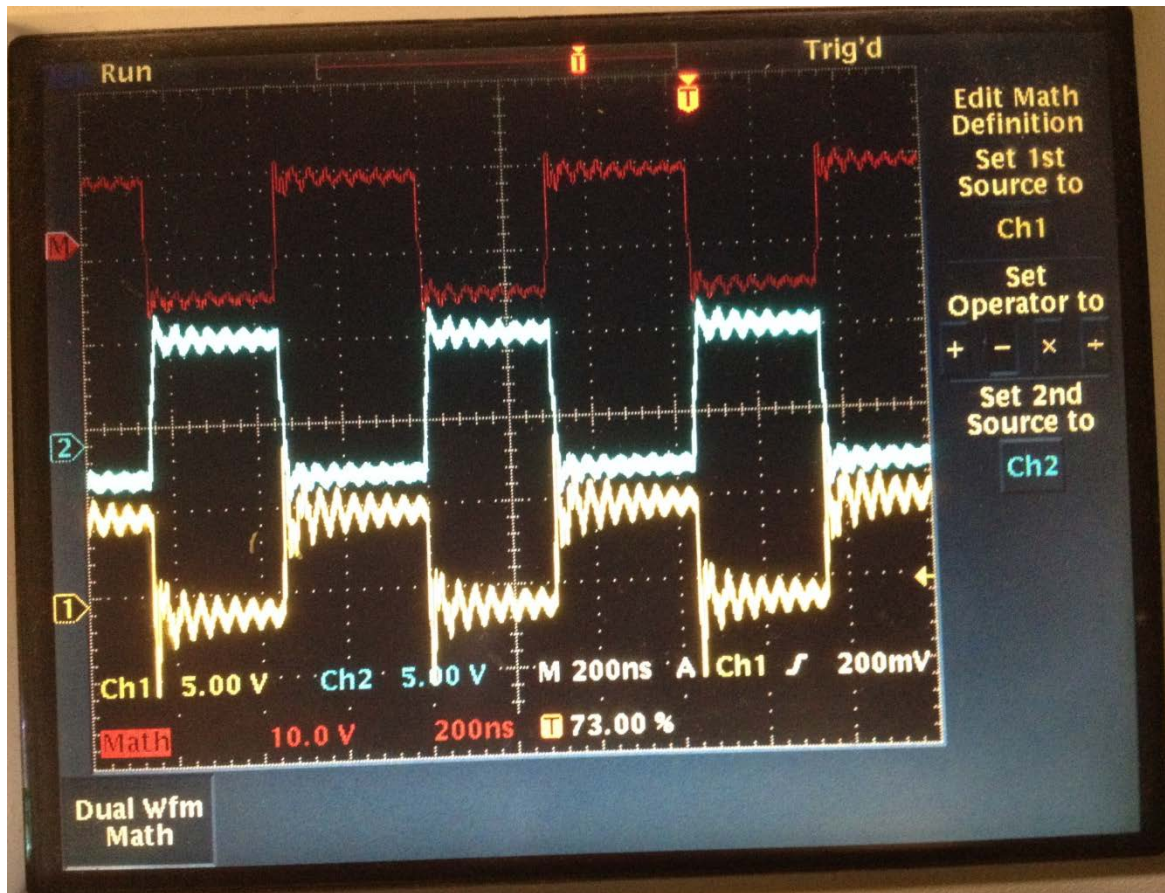

Signal	OUTPUT
	Look like expected, above, Frequency reads 1.54MHz?
“Synch Out1” Pins 1&6	
“Synch Out2” Pins 1&6	
Synch Out3” “Pins 1&6	
“Synch Out4” Pins 1&6	

“Synch Out5” Pins 1&6	
“Synch Out6” Pins 1&6	

Pin 1 (1.54MHz square) and pin 2 (25.7KHz Pulse) showing that one synch pulse should last for an entire square wave period (the probe setup is incorrect for CH2, it should have been x10, and the amplitude should have read 2.00V, not 200mV):

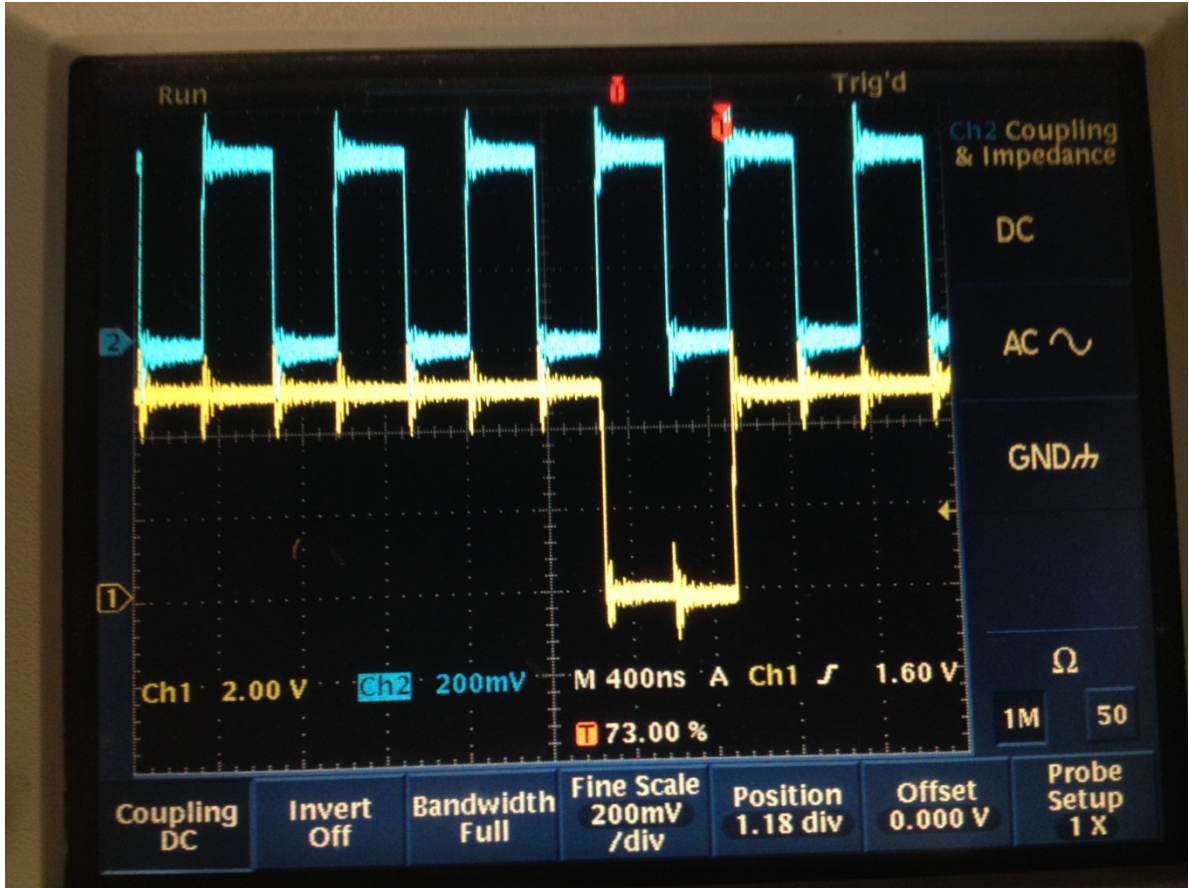

Signal	OUTPUT Look like expected, above?
“Synch Out1” Pins 1&2	
“Synch Out2” Pins 1&2	
Synch Out3” “Pins 1&2	
“Synch Out4” Pins 1&2	



“Synch Out5” Pins 1&2	
“Synch Out6” Pins 1&2	

Connect CH1 to Pin 2 (1.54MHz square) and CH2 to pin 1 (25.7KHz Pulse) and show that the synch pulses should have a frequency of 25.7KHz (within reading error). (Again, the probe setup is incorrect for CH2, it should have been x10, and the amplitude should have read 2.00V, not 200mV):

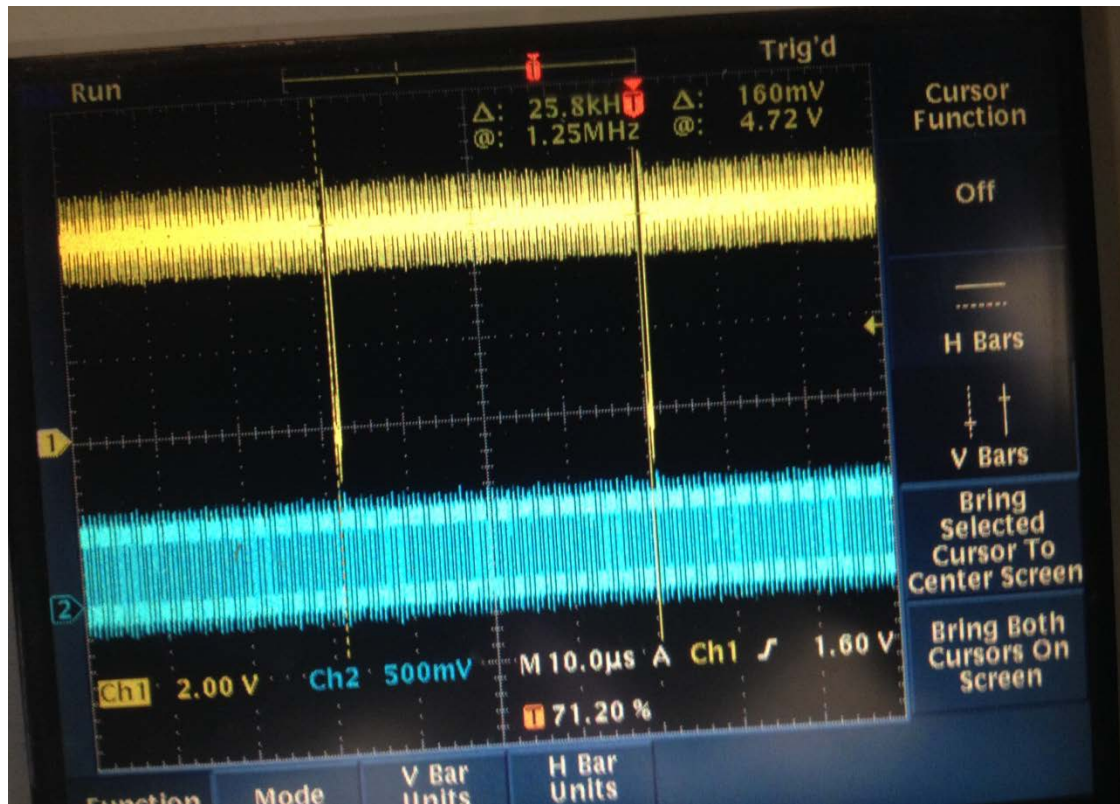

Signal	OUTPUT Look like expected, above?
“Synch Out1” Pins 1&2	
“Synch Out2” Pins 1&2	
Synch Out3” “Pins 1&2	
“Synch Out4” Pins 1&2	

“Synch Out5” Pins 1&2	
“Synch Out6” Pins 1&2	

Use two channels of your oscilloscope, and set the math to display CH1-CH2. Connect the GNDs of the scope together, and ground them to the chassis. Connect CH1 to Pin 2 and Ch2 to pin 7 and show that the differential synch pulses result in a negative going pulse:

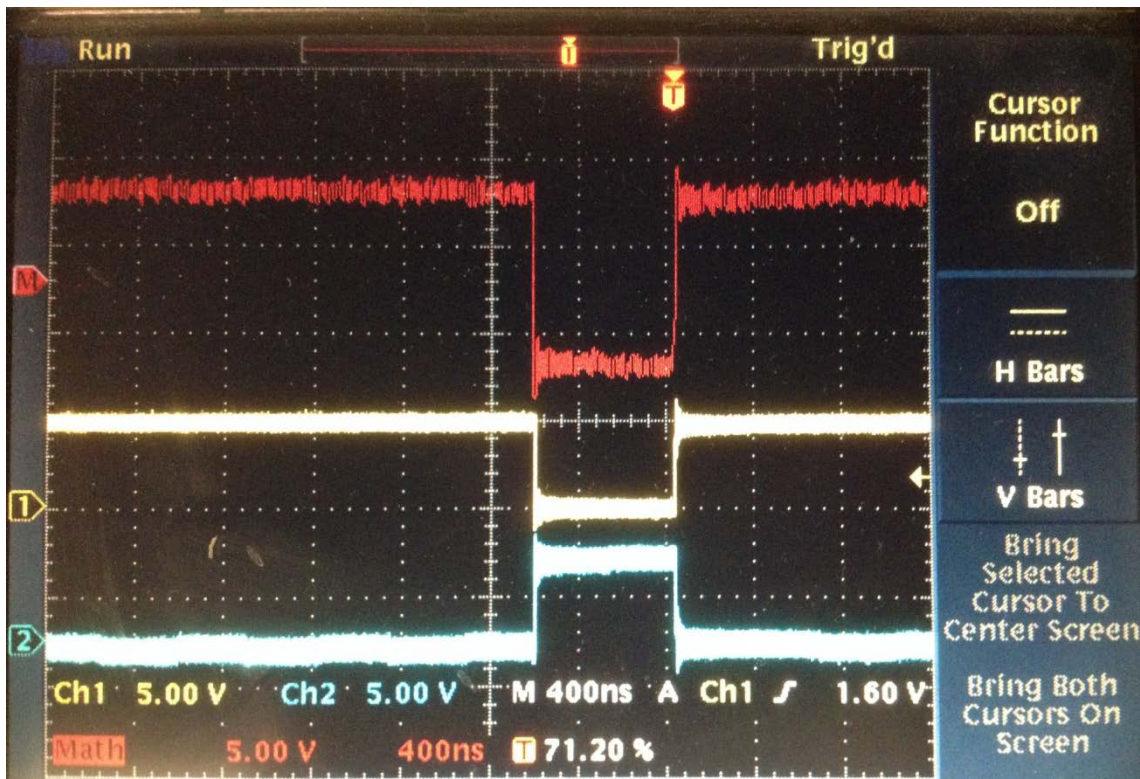

Signal	OUTPUT Look like expected, above?
“Synch Out1” Pins 2&7	
“Synch Out2” Pins 2&7	
Synch Out3” “Pins 2&7	
“Synch Out4” Pins 2&7	

"Synch Out5" Pins 2&7	
"Synch Out6" Pins 2&7	