

Caltech

REQUEST FOR QUOTATION NO. 2015-14
FOR
FABRICATION OF ANNULAR END REACTION MASS

DATE OF ISSUANCE: **September 8, 2015**

**QUOTES TO BE RECEIVED BY CALTECH NO
LATER THAN**

DATE: **OCTOBER 2, 2015**
TIME: 4:00 PM PACIFIC TIME (PT)

COMMUNICATIONS TO REFERENCE
RFQ NO. 2015-14
Internal Req. # C1501364

Send completed copy of your Quote to the attention of:

Name: Hannah Hansen
Email: hannah.hansen@ligo.org
Department: LIGO
Title: LIGO Laboratory Business Manager
LIGO Hanford Observatory-Business Office
PO Box 159
Richland WA 99352
Phone: (509) 372-8264
Fax: (509) 372-8137

Table of Contents

1. Introduction and General Instructions
2. Quotation Responses
3. Statement of Work
4. Selection

1. INTRODUCTION AND GENERAL INSTRUCTIONS

This is a request for information. This solicitation does not constitute a commitment, implied or otherwise, that Caltech will take procurement action in this particular matter. The Institute is seeking a qualified firm to provide Fabrication six Annular End Reaction Masses (AERMs.)

The following provides background information and general instructions regarding preparation of your quote in response to this RFQ.

1.1. LIGO – Information

The Laser Interferometer Gravitational-Wave Observatory ([LIGO](#)) is being built by the [California Institute of Technology \(Caltech\)](#) and the [Massachusetts Institute of Technology \(MIT\)](#). Funded by the [National Science Foundation](#), LIGO functions as a national resource for both physics and astrophysics. When it reaches maturity, the observatories will be open for use by the national community and will become part of a planned worldwide network of gravitational-wave observatories.

1.2. Instructions

Quotes must contain a complete response to requests in the RFQ.

- Electronic submissions are preferred and can be made to the email address on the cover page of this document.
- Printed submissions must be on 8 ½" x 11" paper and addressed to the Subcontract s Administrator using the name and address on the cover page of this document.
- Each must be identified with RFQ No. appearing on the cover page.

1.3. Submittal Deadline

One (1) copy of your complete quote must be delivered no later than 4:00pm PT on the due date identified on the cover page of this document. All late quotes will be considered non-responsive and returned unopened to the vendor except under the following circumstances:

- When sent by U.S. Postal Service, and the postmark or receipt for registered or certified mail establishes the time of deposit with the postal service, and Caltech determines that the late receipt was due solely to delay in the mail for which the offeror was not responsible; or
- When only one responsive, responsible quote is received.

Any quote, portion of a quote or unsolicited offer revision received by Caltech after the time and date specified for receipt of quotes is late. Any volume of a quote received after the time and date specified will cause the entire quote to be late. Caltech's policy is not to consider revisions or supplementary information received after the time and date specified on the cover page, unless the revisions or supplements have been specifically requested by Caltech, and then only to the extent specified

1.4. Reimbursement of RFQ Costs

No reimbursement shall be made by Caltech for any cost incurred in preparing a quote for or in response to this request.

All responses shall be deemed to be the property of Caltech.

1.5. Offer or Authorized Representative

Responses should be signed by personnel authorized to bind your company to a contract and include the contact information of the person or persons assigned to conduct negotiations.

1.6. Caltech Authorized Representative

All inquiries concerning this request shall be in writing (electronic or hard copy) and shall be emailed (preferred method), mailed, or faxed to the contracting officer listed on the cover page of this document.

1.7. Interpretation and Addenda

During the solicitation period, requests to clarify certain aspects of the solicitation package, or for additional information, must be in writing (electronic or hard copy) and addressed directly to the Contracting officer listed on the cover page of this document. Caltech's responses providing additional information or clarification will be sent to all prospective offerors. In addition, any Caltech-initiated changes to the governing documents in the solicitation package will be provided to all prospective offerors as addenda to the package. Caltech will not be responsible for explanations or interpretations of the package by any other means.

1.8. Quote Validity Time

Quote shall be valid for at least ninety (90) calendar days.

2. QUOTE RESPONSES

Quotation responses should include the following:

2.1. Price

A firm, fixed price is requested for the delivery of the machined parts defined in the statement of work (see section 3 below). Please provide a cost breakdown of the price.

2.2. Quality Control

Deliver a QA/QC plan with the quote, or a quote for implementing a suitable QA/QC plan/system.

2.3. Schedule

In accordance with the statement of work referenced below, confirm the requested delivery dates or propose an alternate delivery schedule.

2.4. Exceptions

Identify supplier exceptions to the Terms, Specifications or Drawings. A large number of exceptions or one or more significant exceptions may make your quote unacceptable for evaluation. You must provide a detailed explanation, including the rationale, for any exceptions you take. Offers who submit quotes with exceptions may be selected.

2.5. Fabrication Approach

A brief description of the Contractor's approach for the fabrication of the included work. This summary should include reference to the drawings and any specification documents included.

3. STATEMENT OF WORK

Reference Statement of Work Fabrication of Annular End Reaction Masses LIGO-C1501363-v1

4. SELECTION

Selection is based on the low, responsive, responsible bid.



Statement of Work

Annular End Reaction Mass

C1501363-v1

1.0 Scope

Provide all materials to manufacture six Annular End Reaction Masses without gold coating. Caltech will provide shipping containers and shipping services.

2.0 Document Access

Many supplemental documents and specifications are incorporated into and made a part this Statement of Work. Click on the document links to access these documents from the LIGO Document Control Center (DCC) or go on line to the LIGO Public DCC at <https://dcc.ligo.org/> to access the DCC#.

3.0 Commercial Terms and Applicable LIGO Specifications:

Note: The documents listed below are invoked for this Statement of Work and comprise additional requirements, which are integral to this Statement of Work.

- [LIGO-C080185-v1](#) LIGO Commercial Items or Services Contract General Provisions
- [LIGO-Q0900001-v5](#) Advanced LIGO Supplier Quality Requirements
- [LIGO-Q1100003-v1](#) Acceptable Quality Level (AQL) for Inspection of LIGO Components

4.0 Quality System:

Referring to the above referenced LIGO Specification Q0900001, Suppliers should include a copy of their current ISO 9001, AS9100, or TS16949 certification in their bid package. Suppliers lacking current certification should send a copy of their Quality Manual with their bid package.

5.0 Parts/Assemblies to be manufactured, Quantity Required, and Inspection requirements:

Note: refer to Section 8.0 for delivery schedule and location

Drawing #	Part Description	Total Qty:	AQL number (Inspection Frequency)
LIGO-D1500163-v3	Annular End Reaction Mass	6	1

Note: refer to [LIGO-Q1100003-v1](#) for the AQL table.

6.0 Manufacturing:

6.1 Requirements:

Suppliers must refer to the LIGO Specifications referenced in Section 3 for additional, and in some cases, non-industry standard requirements.

6.2 Sub-Contracted Work:

- LIGO expects that at least 2/3 (by dollar value) of the contracted work be performed by the Supplier named on the Purchase Order. The Supplier shall be responsible for all sub-contracted work.

6.3 Precedence:

The drawings typically represent the finished part as needed for use in service. There may be requirements on the drawing (such as coatings), which are specifically defined as not the responsibility of the supplier in this SOW. Suppliers should always contact a LIGO representative to resolve any discrepancies or uncertainties in the documentation or instructions.

6.4 Special Instructions regarding material:

The function of the AERM is purely mechanical, so there are no figure, homogeneity, or bubble class requirements for the glass. The most important characteristic of the final part is the mass. The drawing has been made assuming the density of SF2 from Schott. Ohara glass PBM2Y is also acceptable, but due to a slightly different density, the diameter of the inner hole would be smaller.

SF2 and PBM2Y have been qualified as meeting our dielectric and vacuum requirements. The same leaded glass as manufactured by other suppliers may also be acceptable depending on chemistry. No other materials may be substituted or added without approval by LIGO.

6.5 Exclusions:

- Supplier is NOT responsible for the application of Gold Coating

7.0 End Item Data Package:

Before delivery of the parts, the Supplier shall provide the following data, as a minimum:

- Any as-built modifications (with approval of the LIGO Contracting Officer) as mark-ups to the drawings
- Material certifications
- Heat Treat and/or Stress Relief certifications, if applicable
- Inspection reports of all dimensional features for the number of parts specified per the AQL number and referenced in the AQL table [LIGO-Q1100003-v1](#) and any other inspection requirements detailed in Section 5 of this SOW
- Certificate of compliance for each part number stating conformance to contract and drawing requirements

8.0 Delivery Requirements:

8.1 Shipping Containers and Packaging:

Caltech will supply shipping containers and transportation, which protects these parts from damage from the transportation environment (weather, handling, accidents, etc.).

8.2 Shipping Destination(s):

The deliveries are FOB at the contractor facility. Caltech will be responsible for shipping the CFM from the Contractor's facility and delivering to Caltech DDP Los Angeles, USA, Incoterms 2000

8.3 Delivery Schedule:

- Staged delivery is acceptable, early delivery is advantageous.
- First part delivery by the end of December 2015
- Following parts delivered at a rate of one per month.

- MANUFACTURING NOTES:**
1. INTERPRET DRAWING PER ASME Y14.5-1994.
 2. DO NOT SCALE FROM DRAWING.
 3. INSPECTION POLISH ALL FACES, ALL SURFACES (INCLUDING INSIDE BARREL), EDGES AND CHAMFER. SURFACES SHALL APPEAR TRANSPARENT WITH NO GREY, SCUFFS OR SCRATCHES VISIBLE TO THE NAKED EYE WHEN VIEWED IN NORMAL ROOM LIGHT AGAINST A BLACK BACKGROUND.
 4. ETCH, GRIND OR SANDBLAST THE SERIAL NUMBER "AERM XX", APPROX. WHERE SHOWN, LETTERING APPROX. 4mm HIGH, WHERE "XX" IS INCREMENTAL STARTING WITH "01".
 5. APPLY ESD GOLD COATING PER E0900138.
 6. NOT A TRANSMISSIVE OPTICAL COMPONENT: NO HOMOGENEITY OR BUBBLE GLASS REQUIREMENT.
 7. MAT'L: 648339.386 (SF2) GLASS. DENSITY: 3.86g/cm³
 8. CRITICAL METRICS: MASS=26.026 Kg

REV.	DATE	DCN #	DRAWING TREE #
v1	06 MAY 2015	-	-
v2	10 JUN 2015	-	-
v3	21 AUG 2015	E1500356-x0	-

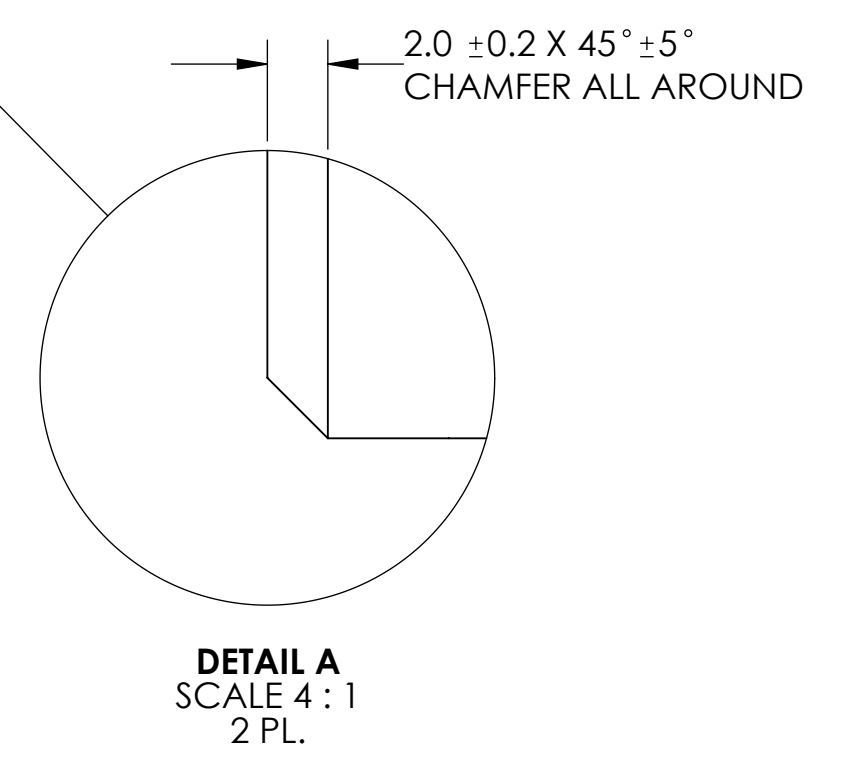
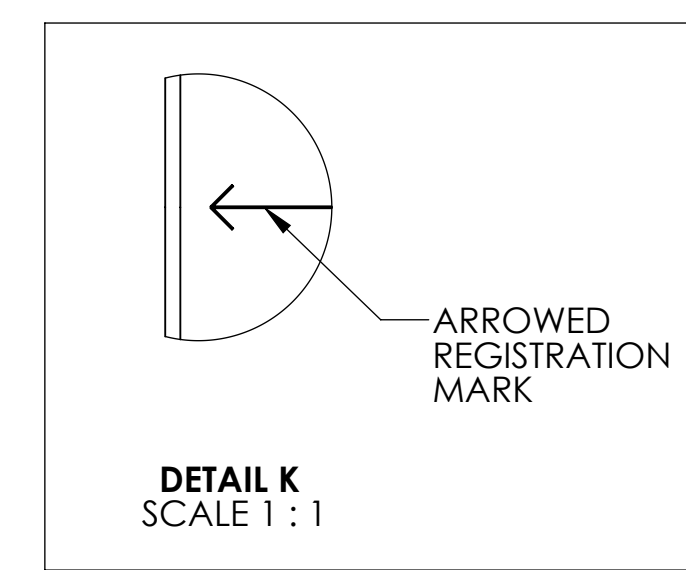
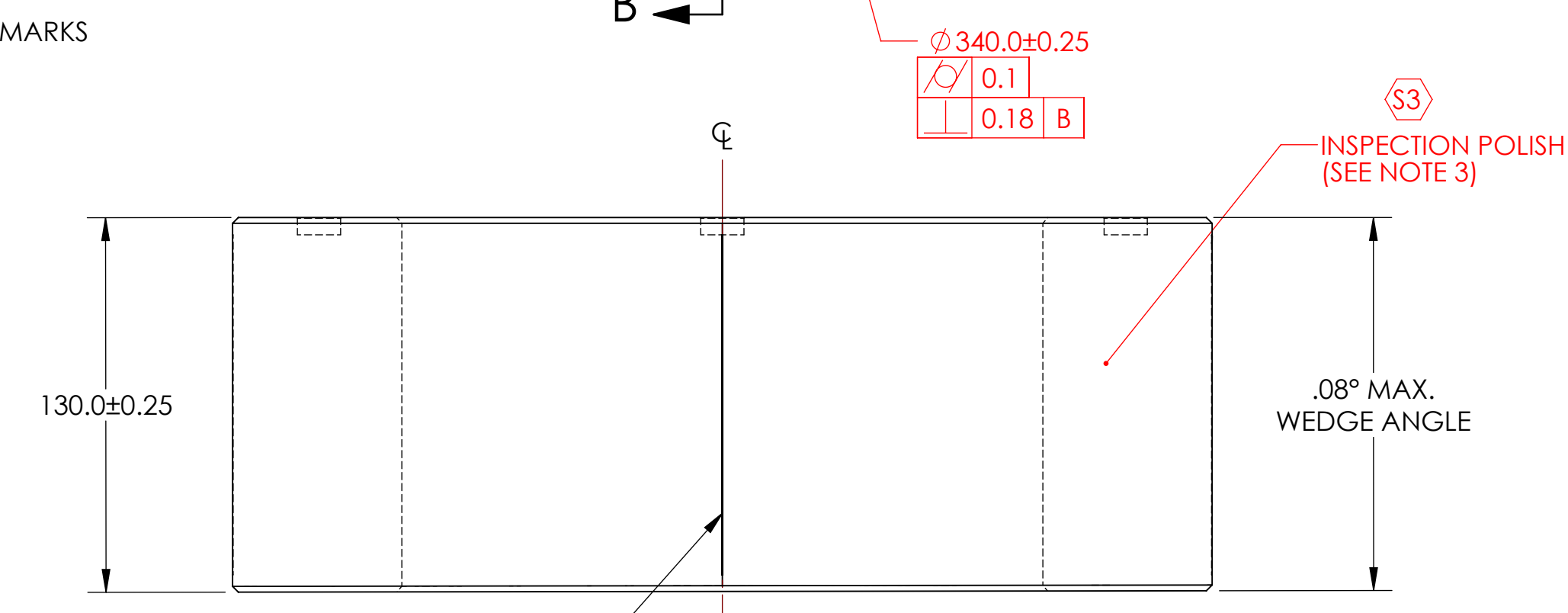
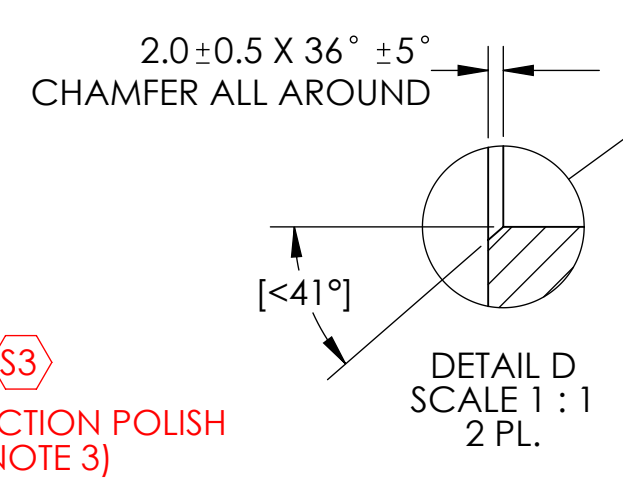
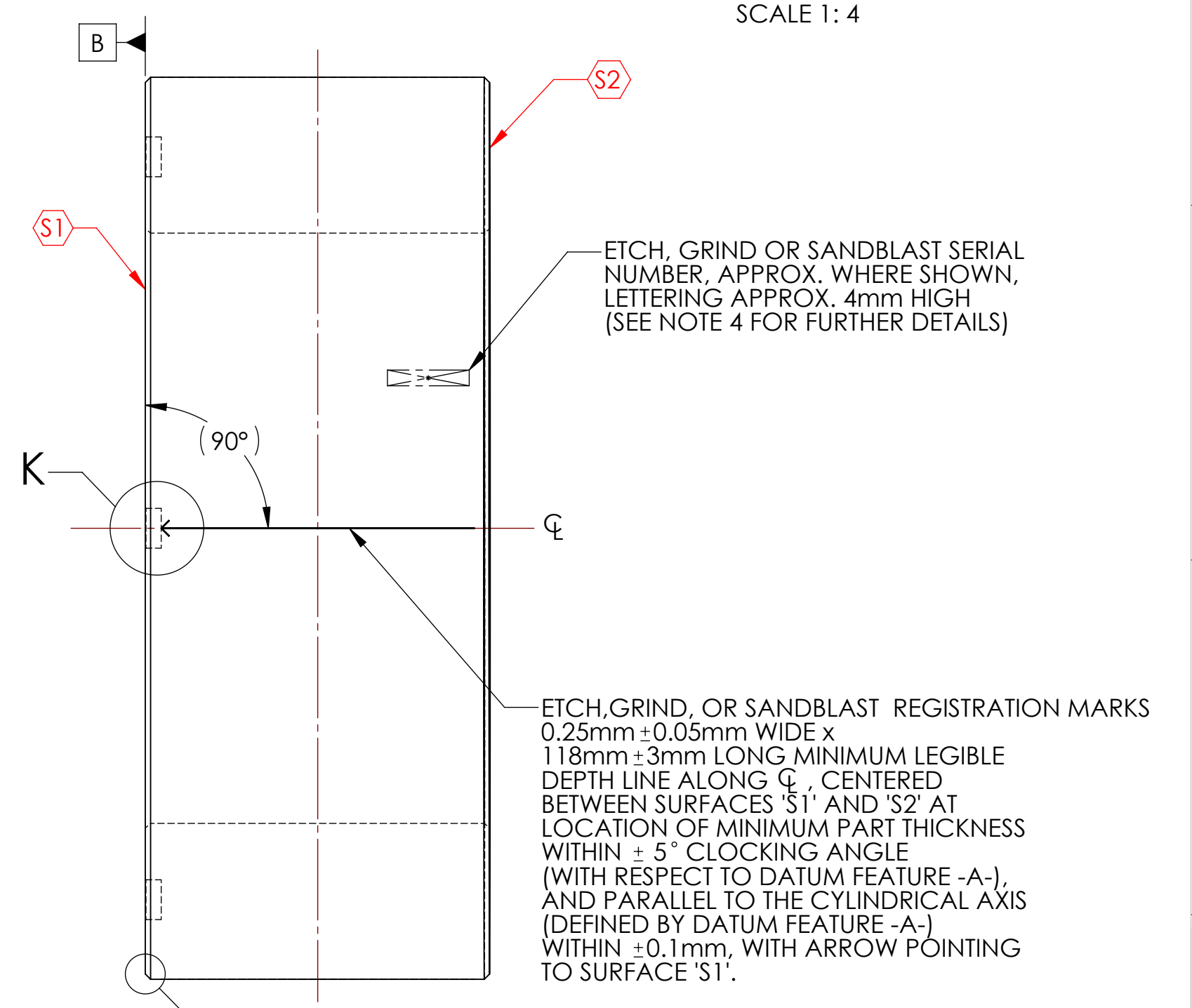
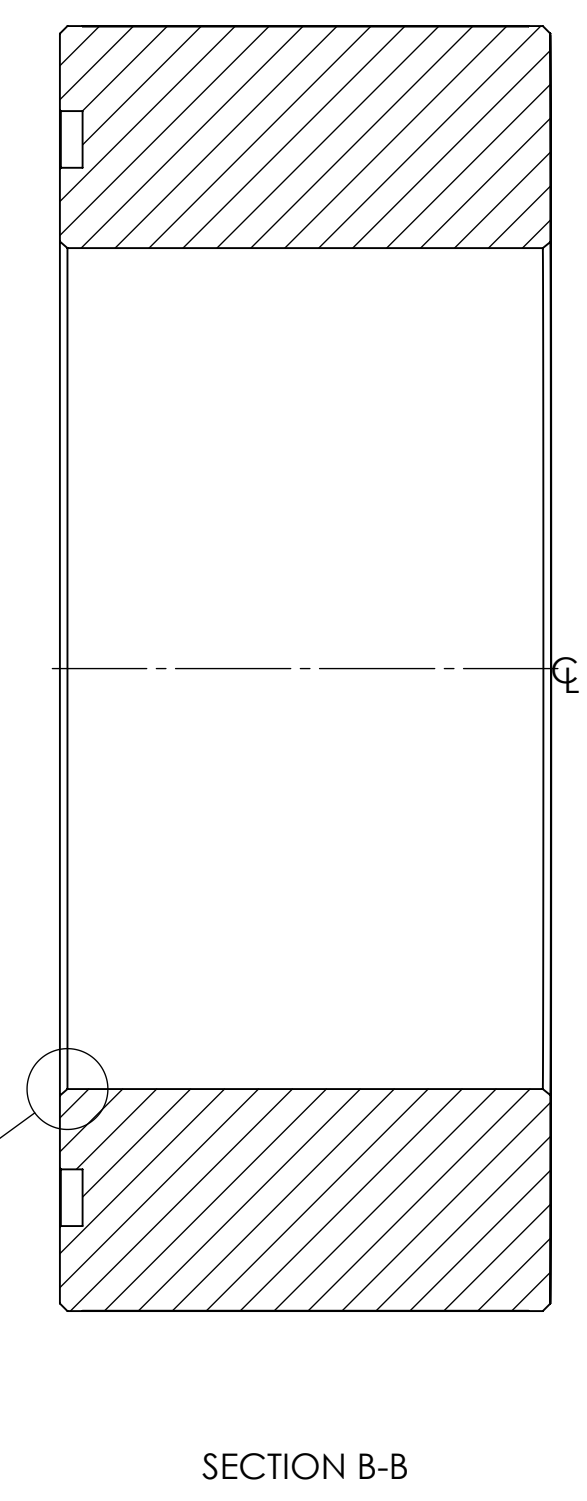
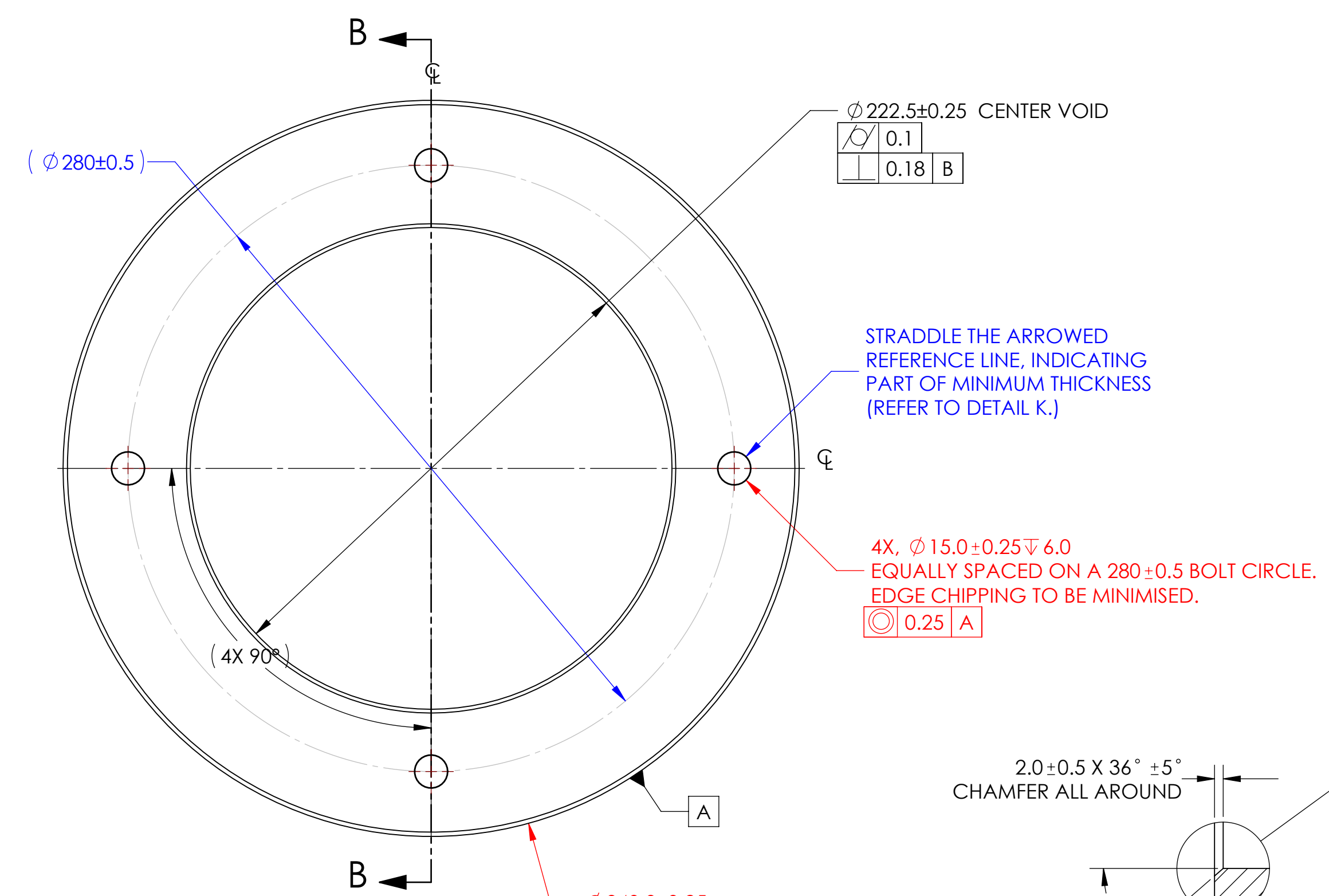
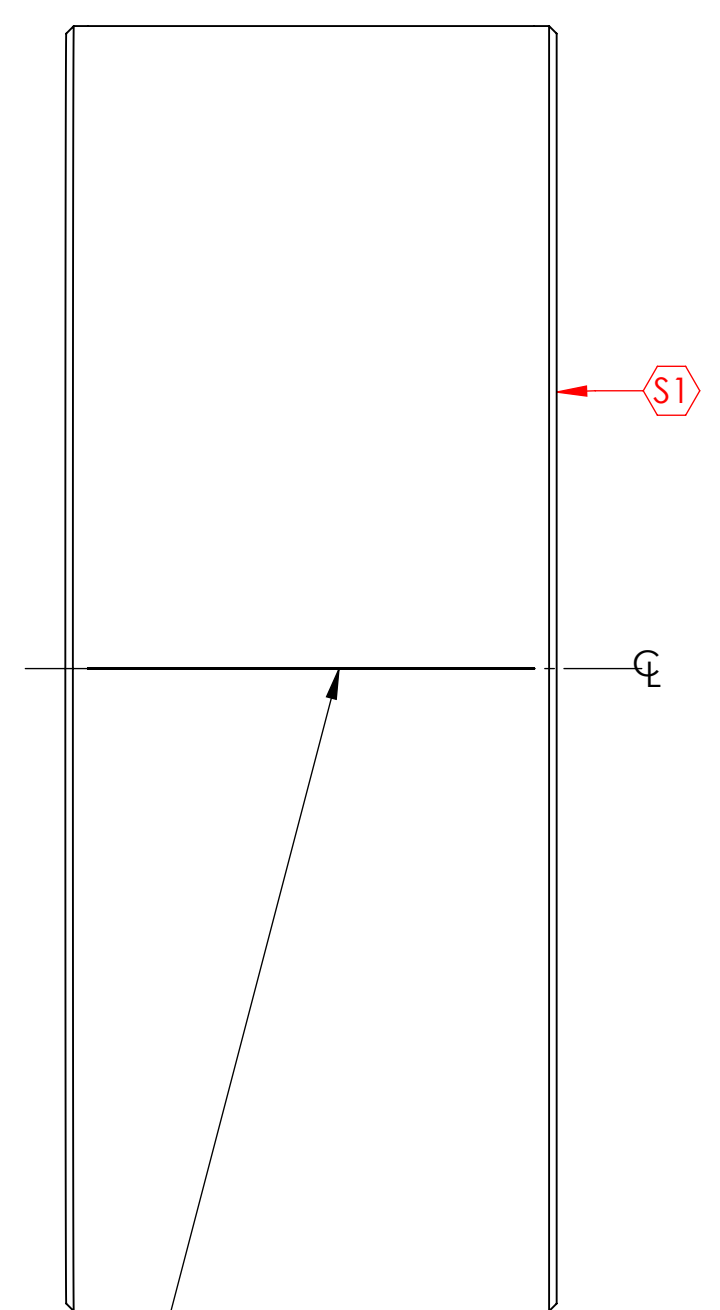
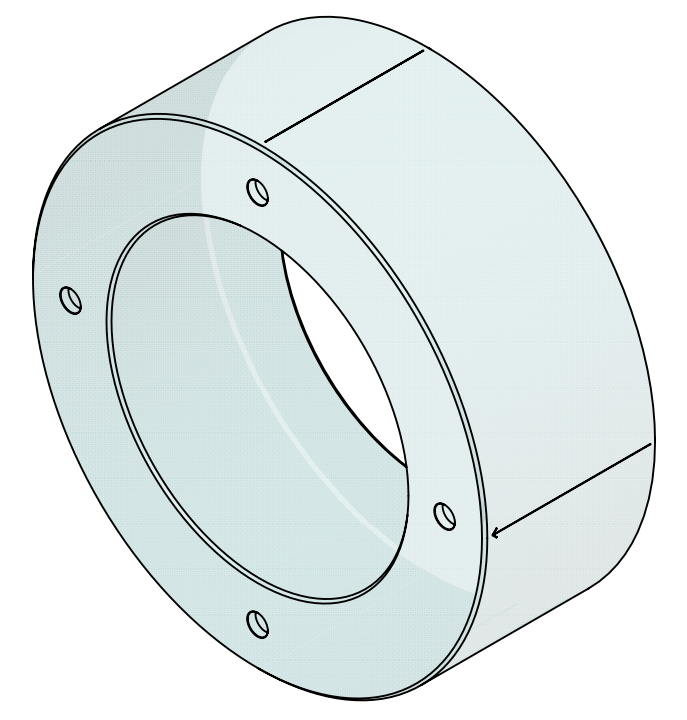
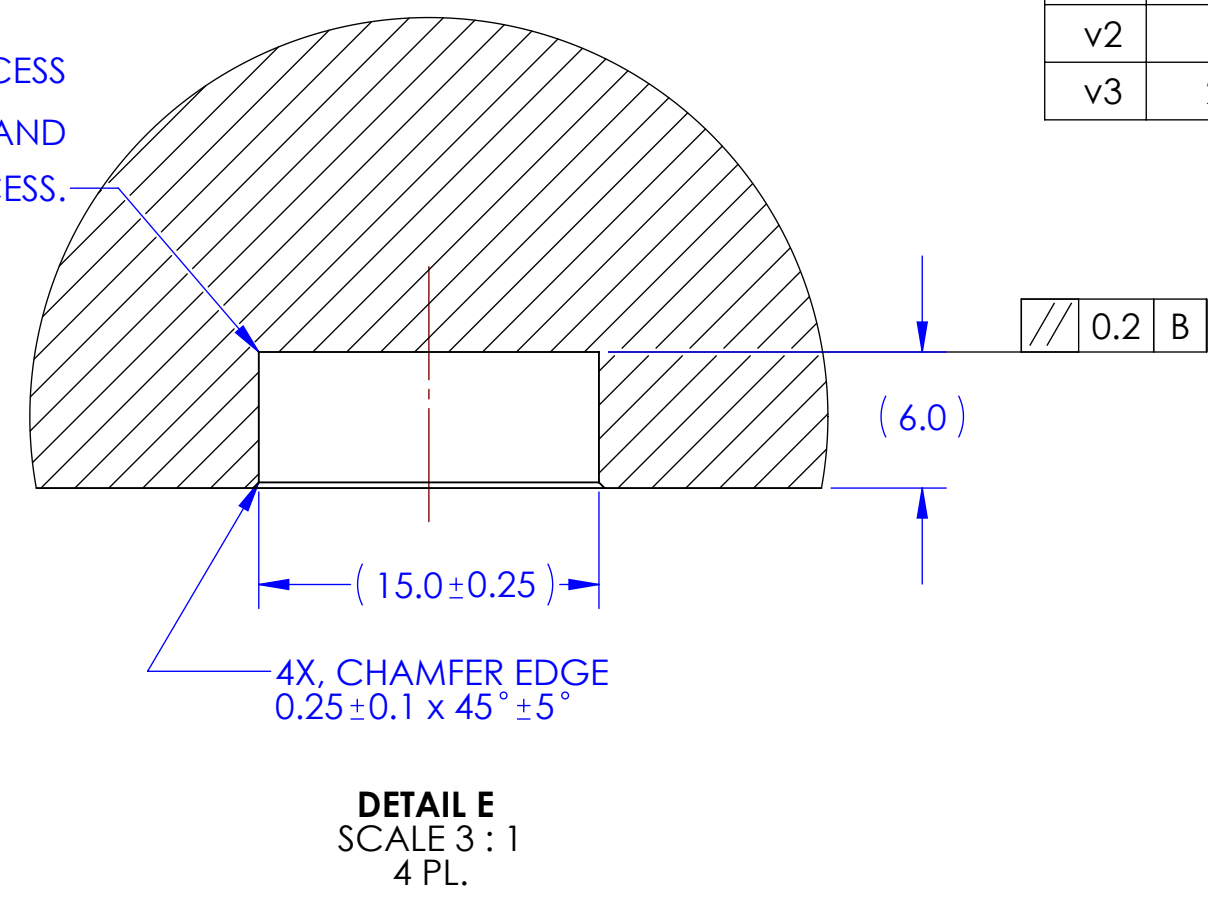
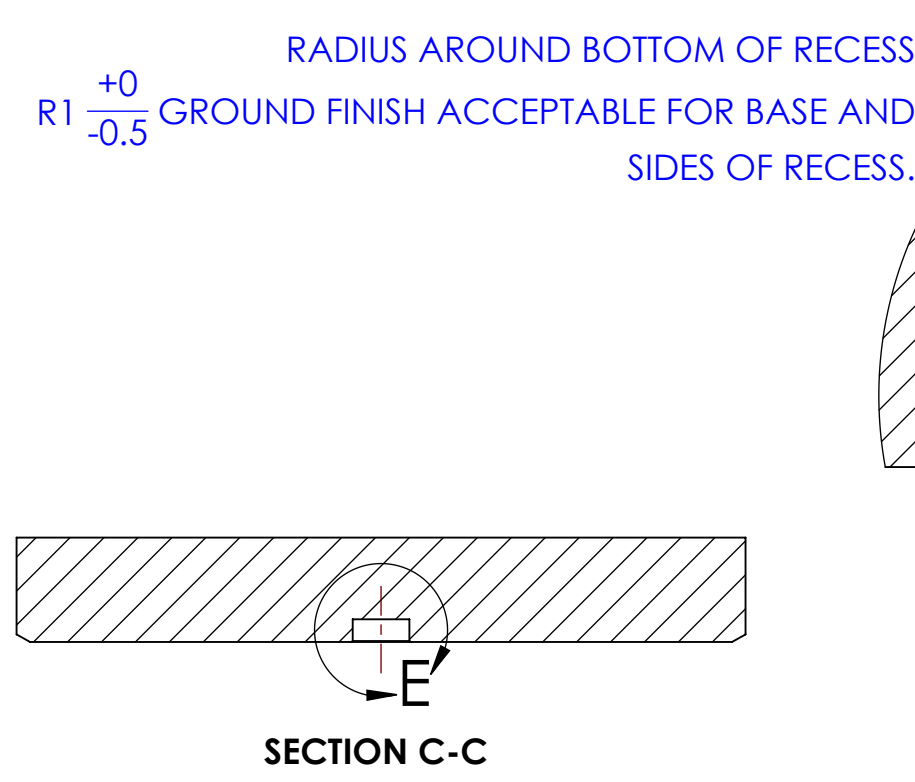
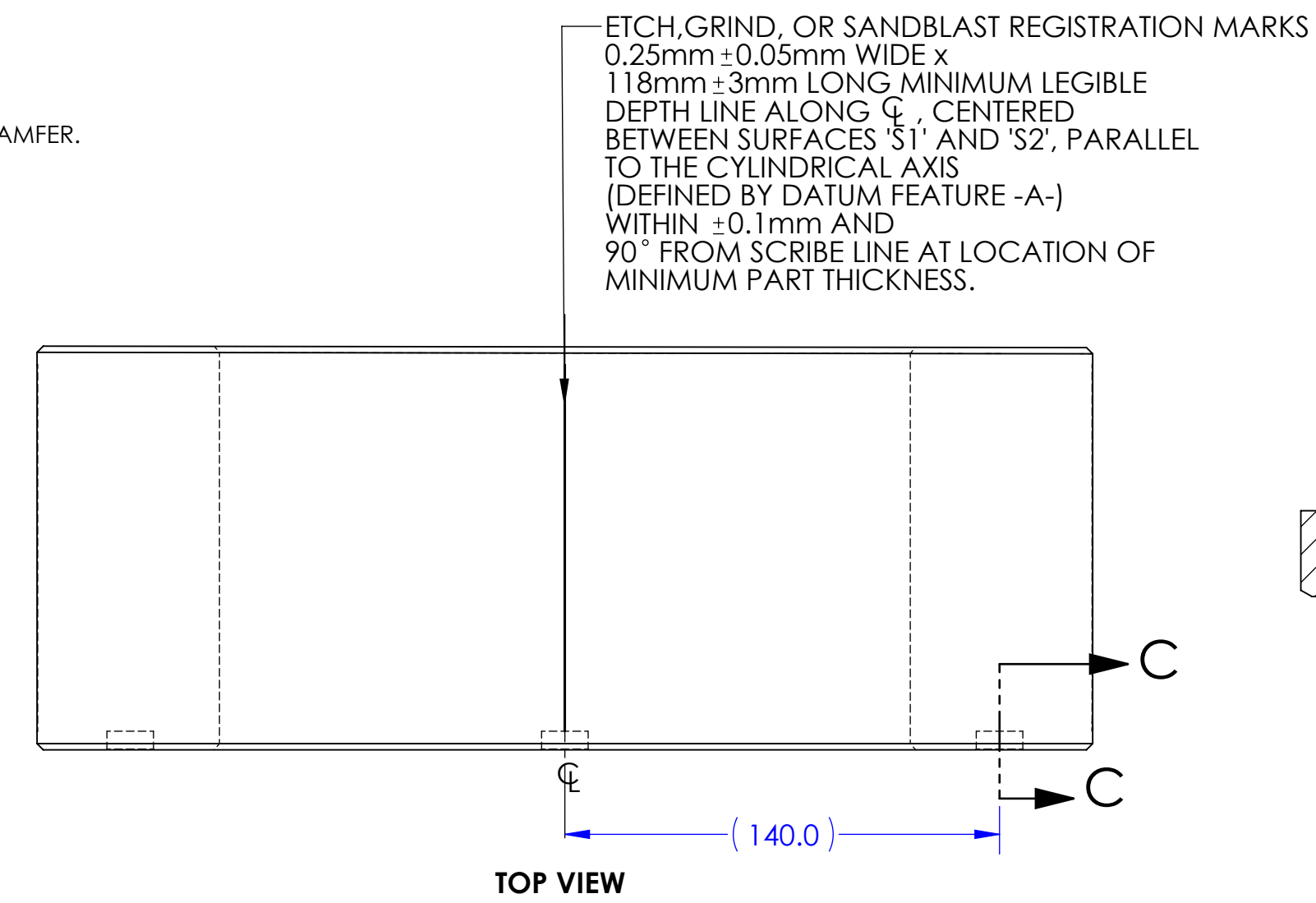

NOTES AND TOLERANCES: (UNLESS OTHERWISE SPECIFIED)				PART NAME	
DIMENSIONS ARE IN MILLIMETERS				Annular End Reaction Mass (AERM)	
TOLERANCES: .X ± 0.1 .XX ± 0.05				CALIFORNIA INSTITUTE OF TECHNOLOGY MASSACHUSETTS INSTITUTE OF TECHNOLOGY	
ANGULAR ± 0.1°				SYSTEM ADVANCED LIGO	SUB-SYSTEM -
MATERIAL SEE NOTE 7		FINISH SEE NOTES μinch		DESIGNER G. Billingsley	DATE 05 MAY 2015
		NEXT ASSY N/A		DRAFTER E. SANCHEZ	DATE 06 MAY 2015
				CHECKER SEE DCC	SIZE D
				APPROVAL SEE DCC	DWG. NO. D1500163
				SCALE 1:2	PROJECTION
				SHEET 1 OF 1	REV. v3

D1500163 RED, End Reaction Mass (ERM), PART PDM REV: X.004, DRAWING PDM REV: X.006



LASER INTERFEROMETER GRAVITATIONAL WAVE OBSERVATORY (LIGO)

COMMERCIAL ITEMS OR SERVICES CONTRACT

GENERAL PROVISIONS CALIFORNIA INSTITUTE OF TECHNOLOGY "INSTITUTE"

GENERAL PROVISION TITLE

1. Offer and Contract
2. Time of Delivery
3. Improper Delivery
4. Assignment
5. Authority of Institute Representative and Required Notices
6. Changes
7. Force Majeure
8. Existing Commercial Computer Software – Licensing
9. Export Licenses
10. Disputes and Governing Law
11. Inspection and Acceptance
12. Insurance
13. Indemnification
14. New Material
15. Order of Precedence
16. Payment
17. Use of Name
18. Title and Risk of Loss
19. Government Title to Property Purchased or Fabricated with Contract Funds
20. Taxes
21. Termination
22. Warranty
23. Audit and Records
24. Site Visits
25. Nondiscrimination
26. Equal Employment Opportunity
27. Anti-Kickback
28. Clean Air Act and the Federal Water Pollution Contract Act
29. Debarment and Suspension
30. Byrd Anti-Lobbying Amendment
31. Copeland "Anti-Kickback" Act
32. Davis Bacon Act
33. Surety Bonds
34. Rights to Inventions – 37 CFR part 401
35. Patent Rights - Bayh-Dole Act [35 U.S.C. 200 et seq.]

(See Page 2 for Individual General Provision Applicability)

APPLICABILITY OF INDIVIDUAL GENERAL PROVISIONS

APPLICABLE TO ALL TRANSACTIONS IN THE UNITED STATES

The term *United States* includes the several States of the United States, the District of Columbia, the Commonwealth of Puerto Rico, the Virgin Islands, American Samoa, Guam, Wake Island, the Canal Zone, and all other territories and possessions of the United States, and the term *States* includes any one of the foregoing.

- | | |
|--|--|
| 1. Offer and Contract | 16. Payment |
| 2. Time of Delivery | 17. Use of Name |
| 3. Improper Delivery | 18. Title and Risk of Loss |
| 4. Assignment | 19. Government Title to Property Purchased or Fabricated with Contract Funds |
| 5. Authority of Institute Representatives and Required Notices | 20. Taxes |
| 6. Changes | 21. Termination |
| 7. Force Majeure | 22. Warranty |
| 8. Existing Commercial Computer Software – Licensing | 23. Audit and Records |
| 10. Disputes and Governing Law | 24. Site Visits |
| 11. Inspection and Acceptance | 25. Nondiscrimination |
| 13. Indemnification | 26. Equal Employment Opportunity |
| 14. New Material | 28. Clean Air Act and the Federal Water Pollution Control Act |
| 15. Order of Precedence | |

TAXES

20. The applicability of State sales tax is addressed on the face of the Purchase Order
[For imports] Value Added Tax (VAT) is addressed on the face of the Purchase Order

APPLICABLE IN SPECIAL CIRCUMSTANCES ACCORDING TO THEIR TERMS

9. **[For exports]** Compliance with Export Regulations
12. **[Suppliers Working on Site]** Insurance
27. **[For Contracts in excess of \$100,000]** Anti-Kickback Enforcement Act of 1986
29. **[For Contracts in excess of \$25,000]** Debarment and Suspension
30. **[For Contracts of \$100,000 or More]** Byrd Anti-Lobbying Amendment
31. **[For designated Construction/Repair Contracts in excess of \$2,000]** Copeland “Anti-Kickback” Act
32. **[For designated Construction/Repair Contracts in excess of \$2,000]** Davis-Bacon Act
33. **[For designated Construction/Repair Contracts in excess of \$500,000]** Surety Bonds
34. **[For designated Experimental, Development or Research Work]** Rights to Inventions- 37 CFR part 401
35. **[For designated Experimental, Development or Research Work]** Patent Rights - Bayh-Dole Act [35 U.S.C. 200 et seq.]

APPLICABLE TO ALL TRANSACTIONS IN THE UNITED STATES

These provisions **do not apply to foreign suppliers** performing outside the United States.

- | | |
|----------------------------------|---|
| 25. Nondiscrimination | 32. Clean Air Act and the Federal Water Pollution Control Act |
| 27. Equal Employment Opportunity | |

This agreement is a subcontract pursuant to an NSF Cooperative Agreement (CA) between the NSF and the Institute, [PHY-0328418](#).

1. **OFFER AND CONTRACT** The following terms, together with such terms, plans, specifications or other documents as attached or incorporated by reference as set forth on the face of this purchase order, constitute the offer of the Institute to Supplier and shall, when accepted, constitute the entire agreement ("Contract") between the Institute and Supplier. Institute hereby gives notice of its objection to any different or additional terms. This Contract is valid only as written. If price, terms, shipping date or other expressed condition of this Contract are not acceptable, the Institute must be notified and any variation must be accepted in writing prior to shipment or delivery. This Contract shall be deemed to have been accepted (a) in the absence of written notification of non-acceptance by the Supplier within a reasonable time, or (b) upon timely delivery of the products identified to the shipping address specified on the face of the order.
2. **TIME OF DELIVERY** Time is of the essence in this Contract. If delivery dates cannot be met, Supplier must notify the Institute immediately. Such notification shall not, however, constitute a change to the terms of this Contract except as the order may be modified in writing by the Institute.
3. **IMPROPER DELIVERY** In addition to other remedies provided by law, the Institute reserves the right to refuse any goods or services and to cancel all or any part of this Contract if Supplier fails to deliver all or any part of the goods or services in accordance with the terms and conditions of this Contract. Acceptance of any part of this order shall not bind the Institute to accept any future shipments nor deprive it of the right to return goods already accepted.
4. **ASSIGNMENT** The Supplier shall have no right to assign this Contract or any benefits from this Contract without prior written consent of the Institute.
5. **AUTHORITY OF INSTITUTE REPRESENTATIVES AND REQUIRED NOTICES; FACSIMILE AND ELECTRONIC SIGNATURES ACCEPTABLE**
 - (a) No order, notice, or direction received by the Supplier and issued pursuant to this Contract shall be binding upon either the Supplier or the Institute, unless issued or ratified in writing by the Institute Purchasing Agent, the Director of Procurement Services, or by representatives designated in writing by either of them.
 - (b) The parties agree that facsimile (fax) or electronic signature copies of contract documents are just as binding as originally-executed documents.
6. **CHANGES** The Institute may at any time, by a written order to the Supplier, make changes within

the general scope of this Contract in any one or more of the following: (a) drawings, designs, or specifications; (b) method of shipment or packing; and (c) time or place of delivery. If any such change causes an increase or decrease in the cost of, or the time required for, the performance of any part of the work under this order, an equitable adjustment may be made in the order price or delivery schedule or both, and the order shall be modified in writing accordingly. Any claim by Supplier for adjustment under this Article must be asserted within 30 days from the date of receipt by Supplier of the notification of change; provided, however, that the Institute, if it decides that the facts justify such action, may receive and act upon any such claim asserted at any time prior to final payment under this purchase order. Nothing in this clause shall excuse Supplier from proceeding with this order as changed.

7. **FORCE MAJEURE** Each party shall not be liable for damages arising out of either its failure to deliver or any delay in delivery caused by strikes, lockouts, fires, war, or acts of God. The Supplier shall notify the Institute in writing as soon as it is reasonably possible after the commencement of any event triggering a delayed delivery or inability to deliver.
8. **EXISTING COMMERCIAL COMPUTER SOFTWARE – LICENSING** (This Article is applicable to the acquisition of any existing commercial computer software under this Contract.)
 - a) Where the Supplier proposes its standard commercial software license, only those applicable portions that comply with the provisions of this Contract are incorporated into and made a part of this Contract.
 - (b) If the Supplier does not propose its standard commercial software license until after this Contract has been issued, or at or after the time the computer software is delivered, such license shall nevertheless be deemed incorporated into and made a part of this Contract under the same terms and conditions as in paragraph (a) above. For purposes of receiving updates, correction notices, consultation, and similar activities on the computer software, any authorized user may acknowledge receipt of a registration form or card and return it directly to the Supplier; however, such signing shall not add to or alter any of the terms and conditions of this Contract.
 - (c) If the specified computer software is shipped or delivered to the Institute, it shall be understood that the Supplier has unconditionally accepted the terms and conditions set forth in this Article, and that the terms and conditions of this Contract (including the incorporated license) constitute the entire agreement between the parties concerning rights in the computer software.
 - (d) Supplier understands and agrees that the computer software may be: (1)

Used, or copied for use, in or with any computer owned or leased by, or on behalf of the Institute provided that the software is not used, nor copied for use, in or with more than one computer simultaneously, unless otherwise permitted; (2) Reproduced for safekeeping (archives) or backup purposes; (3) Modified, adapted, or combined with other computer software, provided that the modified, combined, or adapted portions of the derivative software incorporating restricted computer software shall be subject to the same restricted rights; and (4) Disclosed and reproduced for use by Institute designees in accordance with this Article. (e) Supplier agrees that the software may be used by the Institute in support and furtherance of any of its obligations to the US Government or other funding organization. (f) Supplier warrants that it has the right to sell, license, or transfer the license for the software furnished to the Institute under this Contract in accordance with the terms of this Contract.

9. **EXPORT LICENSES** The Supplier shall comply with all U.S. export control laws and regulations, including the International Traffic in Arms Regulations (ITAR), 22 CFR Parts 120 through 130, and the Export Administration Regulations (EAR), 15 CFR Parts 730 through 799, in the performance of this Contract. In the absence of available license exemptions/exceptions, the Supplier shall be responsible for obtaining the appropriate licenses or other approvals, if required, for exports of hardware, technical data, and software, or for the provision of technical assistance.

10. **DISPUTES AND GOVERNING LAW** (a) Any dispute or claim arising out of, in connection with, or relating to this Contract shall be submitted for resolution to ascending levels of management of the parties. If the dispute cannot be resolved after such negotiations, either party may pursue any appropriate legal recourse not inconsistent with the provisions of this Contract. (b) Pending any decision, appeal or judgment or the settlement of any dispute, Supplier agrees to proceed diligently with the performance of the requirements of this Contract. (c) This Contract shall be construed and enforced in accordance with the laws of the State of California. Disputes will be adjudicated in Los Angeles, California.

11. **INSPECTION AND ACCEPTANCE** The Institute shall have the right to inspect the work and activities of the Supplier under this Contract in such manner and at all reasonable times as are deemed appropriate. Final inspection shall be at the Institute's premises unless otherwise agreed in writing. The Institute, at its option, may reject any non-conforming items and (i) return such non-conforming items to the Supplier at the Supplier's

risk and expense for credit to the Institute at the full invoice price plus all transportation and other related costs, or (ii) hold them for disposition in accordance with the Supplier's instructions at the Supplier's expense, including storage and handling. If the Institute rejects items as nonconforming, the quantities under this Contract will automatically be reduced unless the Institute otherwise notifies the Supplier. The Supplier will not replace quantities so reduced without written instruction by the Institute. Payment for nonconforming goods shall not constitute an acceptance thereof, limit, or impair the Institute's right to assert any legal or equitable remedy, or relieve the Supplier's responsibility for latent defects. The Institute may also opt for a refund of the amount paid under this Contract.

12. **INSURANCE** (This Article is applicable when the Supplier will be entering Institute-controlled premises.) (a) The Supplier shall, at its own expense, provide and maintain during the entire performance period of this Contract at least the following types and minimum amounts of insurance with the Institute named as an additional insured in policies for comprehensive liability insurance with a licensed carrier authorized to do business in the State of California: (1) Workers' Compensation and Employer's Liability Insurance, as required by applicable Federal and State workers' compensation and occupational disease statutes. The Employer's Liability coverage shall be at least \$100,000, except in states with exclusive or monopolistic funds that do not permit worker's compensation to be written by private carriers. (2) Comprehensive Liability Insurance, including automobiles (owned, non-owned, or leased), completed operations, products, and contractual liability, for a combined single limit of not less than \$1,000,000 for all deaths, injuries, and property damage arising from one accident or occurrence. (b) Insurance Certificates and Endorsements. Before commencing work under this Contract, the Supplier shall furnish (i) certificates of insurance for the coverages specified in paragraph (a) above, and (ii) an additional insured endorsement naming the Institute as an additional insured to the Contract for the coverage specified above. Such certificates and the endorsement shall provide that any cancellation or material change in the insurance policies shall not be effective (i) for such period as the laws of the State in which this Contract is to be performed, or (ii) until 30 days after the insurer or the Supplier gives written notice to the Institute, whichever period is longer. Also, such certificates and the endorsement shall (i) cover contractual liability assumed under this Contract, and (ii) be primary and noncontributing to any insurance procured by the Institute. The Supplier agrees to

permit the Institute to examine its original policies, should the Institute so request. Should the Supplier at any time neglect or refuse to provide the insurance required herein, or should such insurance be canceled, the Institute shall have the right to procure same and the costs thereof shall be deducted from monies then due or thereafter to become due to the Supplier.

13. **INDEMNIFICATION** The Supplier agrees to defend, indemnify and hold harmless the Institute from and against all claims, liability and expenses, including reasonable legal fees, arising from any actual or claimed: (i) injury to any person or property resulting from any act or omission of Supplier, its employees or agents, excepting such liability as may result solely from the negligent acts or omissions of the Institute or its employees; and (ii) infringement of any patent, copyright, or trademark by reason of the sale or use of the goods provided by Supplier hereunder. The Supplier's obligations hereunder shall survive acceptance of the goods and payment thereof by the Institute.
14. **NEW MATERIAL** Unless this Contract specifies otherwise, the Supplier represents that the supplies are new and are not of such age or so deteriorated as to impair their usefulness or safety. If the Supplier believes that furnishing other than new material will be in the Institute's interest, the Supplier shall so notify the Purchasing Agent in writing and request authority to use such material.
15. **ORDER OF PRECEDENCE** To the extent there is inconsistency among any documents relating to this order, the inconsistency will be resolved in the following order of priority: (a) These General Provisions; (b) The details specified on the order, or description of products or services; (c) any other documents the Institute agrees in writing to incorporate by reference.
16. **PAYMENT** (a) Invoices shall be submitted in duplicate to the attention of the Institute's Accounts Payable Department, unless otherwise specified, and shall contain the following information as applicable: (i) Contract number, (ii) item number, (iii) description of supplies or services, (iv) size, (v) quantity, (vi) unit price, (vii) extended totals and (viii) any other information which may be specified on the face of this Contract. Any applicable state sales or use taxes or Federal excise taxes shall be shown separately on the invoice. (b) The Institute shall pay the Supplier, upon the submission of proper invoices, the prices stipulated in this Contract for supplies delivered and accepted or services rendered and accepted, less any deductions provided in this Contract. (c) The Institute shall make its best effort to make payments within the net period, if any, specified in the Contract, measured from the date of receipt of

the goods or services at the destination or the date of receipt of the invoice, whichever is later. Discount time periods will be measured from the same date. Payment shall be deemed to have been made on the date the check is mailed or on the date on which an electronic funds transfer was made. In no event will the Institute be liable for or pay a surcharge, interest, or any kind of penalty as a result of the Institute's payment not being made within the net period, if any, specified in the Contract or the date of payment by electronic funds transfer. (d) Payment for goods or services in accordance with this paragraph will not waive or otherwise affect the right of the Institute to inspect such goods or services or to reject, or revoke acceptance of, nonconforming goods.

17. **USE OF NAME** Supplier agrees not to use the name or trademarks of the Institute or any member its staff in sales promotional work or advertising, or in any form of publicity, without the prior written permission of the Institute.
18. **TITLE AND RISK OF LOSS** (a) Unless otherwise provided in Section 19 or elsewhere in this Contract, title to tangible property (property of any kind except intangible property and debt instruments) furnished under this Contract shall pass to the Institute upon formal acceptance by the Institute, regardless of when or where the Institute takes physical possession, unless the Contract specifically provides for earlier passage of title. (b) Risk of loss shall not pass to the Institute until the tangible property called for in this Contract has been actually received and accepted by the Institute at the destination specified. Supplier assumes all responsibility for packing, crating, marking, transportation and liability for loss or damage in transit, notwithstanding any agreement by Institute to pay freight, express or other transportation charges. Supplier agrees to trace lost or delayed shipments at the request of the Institute.
19. **GOVERNMENT TITLE TO PROPERTY PURCHASED OR FABRICATED WITH CONTRACT FUNDS** Title to tangible property shall vest in the Government upon acquisition when the tangible property is intended to be installed at, incorporated into, built, or necessary for the construction or operation of either the Hanford or Livingston Observatories. All Government property acquired in accordance with this Section 19 shall be subject to the requirements set forth below:
 1. Title.

(a) Tangible Property means property of any kind except intangible property and debt instruments. Title to all tangible property procured with funds provided through this Contract, and subject to this Section 19, shall vest in the Government as follows:

1) If this Contract contains a provision directing the Supplier to purchase material which the Government will reimburse as a direct item of cost under the Institute's primary Award, title to property shall pass to and vest in the Government upon delivery of such property to the Government, to the Institute, to the Supplier, to any subcontractor, or to any agent of the Government, of the Supplier, or of any subcontractor; and

2) Title to all other property shall pass to and vest in the Government upon the earliest to occur of the following:

(i) issuance of the property for use in contract performance pursuant to this Contract;

(ii) commencement of processing of the property or its use in contract performance pursuant to this Contract; or

(iii) reimbursement of the cost of the property by the Institute on behalf of the Government.

2. Legal title to all tangible property furnished by the NSF or acquired from other Government agencies shall remain with the Government, unless otherwise specified in this Contract.

3. Title to Government property shall not be affected by the incorporation or attachment thereof to any property not owned by the Government, nor shall any Government property lose its identity by reason of affixation to any reality.

4. All subcontracts issued or awarded with respect to the performance of this Contract shall include provisions regarding the determination of title to tangible property acquired by the subcontractor in accordance with Sections 18 and 19.

5. Should Supplier purchase tangible property pursuant to this Contract and subject to this Section 19, Supplier shall be a limited agent of the NSF solely for the purpose of transferring and vesting title to such tangible property in the Federal Government. The agent shall be solely responsible for the payment of the purchase price of tangible property acquired, and the agent shall have no authority to bind or obligate the Institute, NSF or the Federal Government for payment of the purchase price to any third party. Such agents shall be and shall remain liable for the risk of loss of, destruction of, or damage to tangible property acquired until such tangible property is transferred to the possession of the Government or acceptance by the Institute.

20. **TAXES** (a) **Except as may be otherwise provided on this order**, the contract price includes all applicable Federal, State, and local taxes and duties. With respect to transactions for which the

Institute may be exempt from any tax or duty, the Institute will provide, upon request, evidence to support its claim to such exemption. (b) The Institute will comply with all Federal and State income tax laws with respect to withholding and year-end tax reporting. (c) The Internal Revenue Service (IRS) requires the Institute to have on file a Taxpayer Identification Number (TIN) for every US person or US business that receives a payment, regardless if the payment is tax reportable or not. This information is provided on IRS Form W-9. US Citizens and Resident Aliens are required to complete a Form W-9 before receiving any payments from the Institute. A TIN can be any of the following: a Social Security Number (SSN) an Individual Taxpayer Identification Number (ITIN) or an Employer Identification Number (EIN). Failure to provide a TIN will result in delay of payment and/or backup withholding. (d) Foreign businesses providing services in the US for the Institute are required to provide the appropriate IRS Form W-8 (i.e., Form W-8BEN, W-8ECI, or W-8IMY). (e) Foreign individuals providing services in the US for the Institute are required to provide an IRS Form W-8BEN or IRS Form 8233 depending on the appropriate tax withholding treatment.

21. **TERMINATION** (a) **For Cause.** The Institute may terminate this Contract, or any part of it, for cause in the event of any default by the Supplier, or if the Supplier fails to comply with any Contract terms and conditions, or fails to provide the Institute, upon request, with adequate assurances of future performance. In the event of termination for cause, the Institute shall not be liable to the Supplier for any amount for supplies or services not accepted, and the Supplier shall be liable to the Institute for any and all rights and remedies provided by law. If it is determined that the Institute improperly terminated this Contract for cause, such termination shall be deemed a termination for convenience. (b) **For Convenience.** The Institute reserves the right to terminate this Contract, or any part hereof, for its sole convenience. In the event of such termination, the Supplier shall immediately stop all work hereunder and shall immediately cause any and all of its subcontractors to cease work. Subject to the terms of this Contract, the Supplier shall be paid a percentage of the Contract price reflecting the percentage of the work performed prior to the notice of termination, plus reasonable charges the Supplier can demonstrate to the satisfaction of the Institute, using its standard record keeping system, have resulted from the termination. The Supplier shall not be paid for any work performed or costs incurred which reasonably could have been avoided.

22. **WARRANTY** Supplier expressly warrants all goods and services delivered under this Contract to be free from defects in material and workmanship and to be of the quality, size and dimensions ordered. This express warranty shall not be waived by reason of the acceptance of the goods or services or payment by Institute. The Supplier shall provide the Institute with a copy of any standard warranty which is normally offered on a commercial product deliverable under this Contract. The commercial product warranty shall be deemed to be incorporated by reference and the Institute shall be entitled to all rights under such warranty.
23. **AUDIT AND RECORDS** Financial records, supporting documents, statistical records, and other records pertinent to this Contract shall be retained by the Supplier for a period of five years from acceptance by the Institute. Supplier agrees that the Institute, the National Science Foundation, the Comptroller General of the United States, or any of their duly authorized representatives, shall have access to any books, documents, papers and records of the Supplier which are directly pertinent to this Contract, for the purpose of making audits, examinations, excerpts and transcriptions.
24. **SITE VISITS** NSF and the Institute, through authorized representatives, have the right, at all reasonable times, to make site visits to review project accomplishments and management control systems and to provide such technical assistance as may be required. If any site visit is made by NSF or the Institute on the premises of the Supplier or a contractor under a subcontract, the Supplier shall provide and shall require its contractors to provide all reasonable facilities and assistance for the safety and convenience of the Institute or Government representatives in the performance of their duties. All site visits and evaluations shall be performed in such a manner that will not unduly delay the work.
25. **NONDISCRIMINATION** The Contract is subject to the provisions of Title VI of the Civil Rights Act of 1964 [42 U.S.C. § 2000d], Title IX of the Education Amendments of 1972 [20 USC §§ 1681 et seq.], the Rehabilitation Act of 1973 [29 U.S.C. § 794], the Age Discrimination Act of 1975 [42 U.S.C. §§ 6101 et seq], and all regulations and policies issued by NSF pursuant to these statutes. In accordance with these statutes, regulations, and policies, no person on the basis of race, color, national origin, sex, disability, or age shall be excluded from participation in, be denied the benefits of, or otherwise be subjected to discrimination under the Contract.
26. **EQUAL EMPLOYMENT OPPORTUNITY** This Contract is subject to the requirements of Executive Orders 11246 and 11375 and the rules and regulations or the Secretary of Labor (41 CFR Chapter 60) in promoting Equal Employment Opportunities.
27. **ANTI-KICKBACK ENFORCEMENT ACT OF 1986** This Contract is subject to the provisions of the Anti-Kickback Enforcement Act of 1986, Public Law 99-634 (41 U.S.C. 51-58). By accepting this order, Seller certifies that it has not paid kickbacks directly or indirectly to any Institute employee for the purpose of obtaining this or any other Institute purchase order or to obtain favorable treatment in an Institute matter.
28. **CLEAN AIR ACT AND THE FEDERAL WATER POLLUTION CONTROL ACT** – Should this Contract be for an amount in excess of \$100,000, Supplier agrees to comply with all applicable standards, orders or regulations issued pursuant to the Clean Air Act (42 U.S.C. 7401 et seq.) and the Federal Water Pollution Control Act as amended (33 U.S.C. 1251 et seq.). Further, Supplier agrees as follows:
- To comply with all the requirements of Section 114 of the Clean Air Act [42 U.S.C. §7414] and Section 308 of the Clean Water Act [33 U.S.C. § 1318], respectively, relating to inspection, monitoring, entry, reports and information, as well as other requirements specified in Section 114 and Section 308 of the Clean Air Act and the Clean Water Act, respectively, and all regulations and guidelines issued thereunder before the Contract.
 - That no portion of the work required by the Contract will be performed in a facility listed on the Environmental Protection Agency List of Violating Facilities on the date that the Contract was awarded unless and until EPA eliminates the name of such facility or facilities from such listing.
 - To use its best efforts to comply with clean air standards and clean water standards at the facility in which the Contract is being performed.
 - To insert the substance of the provisions of this article into any nonexempt subcontract.
29. **DEBARMENT AND SUSPENSION** – (a) Supplier shall fully comply with the requirements stipulated in 2 CFR Part 180, as modified by 45 CFR 620.330 and shall ensure that any lower tier covered transaction, as described in 2 CFR 180.220 and modified by 45 CFR 620.200 and 620.220 includes a term or condition requiring compliance with these requirements. The Supplier acknowledges that failing to disclose the information required under 45 CFR § 620.335 may result in the termination of the Contract, or pursuance of other available remedies, including suspension and debarment. Supplier may access the Excluded Parties List System at <http://epls.arnet.gov>. (b) No contract at any tier shall be made to parties listed on the General Services Administration's List

of Parties Excluded from Federal Procurement or Nonprocurement Programs in accordance with E.O.s 12549 and 12689, "Debarment and Suspension." This list contains the names of parties debarred, suspended, or otherwise excluded by agencies, and contractors declared ineligible under statutory or regulatory authority other than E.O. 12549. Supplier, whose Contract exceeds the small purchase threshold, shall provide the required certification regarding its exclusion status and that of its principal employees.

30. **[FOR CONTRACTS OF \$100,000 OR MORE] BYRD ANTI-LOBBYING AMENDMENT** - Supplier warrants that Supplier has applied or bid on a Contract of \$100,000 or more and has filed the required certification. Each subcontracting tier must certify to the tier above that it will not and has not used Federal appropriated funds to pay any person or organization for influencing or attempting to influence an officer or employee of any agency, a member of Congress, officer or employee of Congress, or an employee of a member of Congress in connection with obtaining any Federal contract, grant or any other award covered by 31 U.S.C. 1352. Each tier shall also disclose any lobbying with non-Federal funds that takes place in connection with obtaining any Federal award. Such disclosures are forwarded from tier to tier up to the recipient.
31. **[FOR CONSTRUCTION/REPAIR CONTRACTS >\$2000] Copeland "Anti-Kickback" Act (18 U.S.C. 874 and 40 U.S.C. 276c)** Supplier shall comply with the Copeland "Anti-Kickback" Act (18 U.S.C. 874), as supplemented by Department of Labor regulations (29 CFR part 3, "Contractors and Subcontractors on Public Building or Public Work Financed in Whole or in Part by Loans or Grants from the United States").
32. **[FOR CONSTRUCTION/REPAIR CONTRACTS >\$2000] Davis-Bacon Act, as amended (40 U.S.C. 276a to a-7)** Supplier shall comply with the Davis-Bacon Act (40 U.S.C. 276a to a-7) and as supplemented by Department of Labor regulations (29 CFR part 5, "Labor Standards Provisions Applicable to Contracts Governing Federally Financed and Assisted Construction").
33. **[FOR CONSTRUCTION/REPAIR CONTRACTS >\$500,000] Surety Bonds - If so directed**, the Supplier shall furnish separate bid guarantees, performance and payment bonds to the Institute. Each bond shall set forth a penal sum in an amount not less than the Contract Price. Each bond furnished by the Supplier shall incorporate by reference the terms of this Contract as fully as though they were set forth verbatim in such bonds. In the event the Contract Price is adjusted by Change Order executed by the Contractor, the

penal sum of both the performance bond and the payment bond shall be deemed increased by like amount. The performance and payment bonds furnished by the Supplier shall be in form suitable to Institute and shall be executed by a surety, or sureties, reasonably acceptable to the Institute.

34. **[For designated Experimental, Development or Research Work] Rights to Inventions** - For non-profit organizations and small business firms, patent rights shall be governed by 37 CFR part 401, titled "Rights to Inventions Made by Non-Profit Organizations and Small Business Firms under Government Grants, Contracts and Cooperative Agreements".
35. **[For designated Experimental, Development or Research Work] Patent Rights** – Bayh-Dole Act [35 U.S.C. 200 et seq.]



LIGO Laboratory / LIGO Scientific Collaboration

LIGO-Q0900001-v5

3 February 2010

Advanced LIGO Supplier Quality Requirements

Jeff Lewis, Bob Anderson, Calum Torrie

Distribution of this document:
LIGO Scientific Collaboration
and LIGO Suppliers

California Institute of Technology
LIGO Project – MS 18-34
1200 E. California Blvd.
Pasadena, CA 91125
Phone (626) 395-2129
Fax (626) 304-9834
E-mail: info@ligo.caltech.edu

Massachusetts Institute of Technology
LIGO Project – NW22-295
185 Albany St
Cambridge, MA 02139
Phone (617) 253-4824
Fax (617) 253-7014
E-mail: info@ligo.mit.edu

LIGO Hanford Observatory
P.O. Box 1970
Mail Stop S9-02
Richland WA 99352
Phone 509-372-8106
Fax 509-372-8137

LIGO Livingston Observatory
P.O. Box 940
Livingston, LA 70754
Phone 225-686-3100
Fax 225-686-7189

<http://www.ligo.caltech.edu/>

email: quality@ligo.caltech.edu

Contents

1. Scope	3
2. Supplier Quality System	3
2.1. Certified or Compliant	3
2.2. Calibration Program	3
3. Procurement Process	3
3.1. Pre-RFP/RFQ Supplier Visit	3
3.2. LIGO Procurement Documentation	3
3.3. Pre-Award Inspection	3
4. Manufacture, Assembly, and Inspection Requirements	4
4.1. Manufacturing Planning / Traveler	4
4.2. First Article Inspection	4
4.3. In-Process Inspection	4
4.4. Final Inspection	4
4.5. Source Inspection	4
4.6. Discrepant Material	4
4.7. Drawing and Specification Change Control	5
4.8. Welding Certifications	5
4.9. End Item Data Package	5

1. Scope

This document is intended for Suppliers and potential Suppliers to LIGO when specified on the Statement of Work (SOW). Supplier requirements are defined, including: the Supplier's Quality System; inspection, material handling, packaging and shipping procedures.

2. Supplier Quality System

2.1. Certified or Compliant

During the Request for Proposal (RFP) or Request for Quote (RFQ) process, preference will be given to potential and current suppliers who are currently ISO 9001, AS9100, or TS16949 certified. LIGO can still contract with suppliers who are not certified but those suppliers typically have ISO 9001 compliant Quality Systems. Potential suppliers having neither an ISO 9001 certified nor compliant Quality System will be required to create a quality document addressing the main points of ISO 9001 with respect to the LIGO work. Only potential suppliers lacking certification shall submit a copy of their Quality System along with the bid package for consideration.

2.2. Calibration Program

The supplier shall maintain an ISO 9001 compliant calibration program of all instruments and tools required for the inspection of all LIGO production parts and assemblies manufactured by the supplier or sub-contractor.

3. Procurement Process

3.1. Pre-RFP/RFQ Supplier Visit

A LIGO representative may conduct a visit or audit to gage a potential supplier's Quality System, facilities, equipment and personnel capabilities, and capacity. The LIGO representative can explain any LIGO specific requirements that are not clear.

3.2. LIGO Procurement Documentation

LIGO will provide the supplier with the following documentation in support of the bid process (if applicable):

- 3.2.1. Statement of Work (SOW)
- 3.2.2. Technical documents, drawings, and specifications, identified by revision. Solid Models are available on request.
- 3.2.3. On-line access to all applicable LIGO specifications

3.3. Pre-Award Inspection

Prior to contract award LIGO staff may perform an audit of the prospective supplier's Quality System. The audit scope includes but is not limited to:

- Understanding of the various LIGO requirements and specifications. This should be an opportunity for both parties to communicate.
- Supplier QA/QC program and how it will be implemented for Advanced LIGO contracts.
- Manufacturing methodologies, especially as regards cleanliness and use of approved materials and fluids.
- Cleaning and packaging methodologies compared to RFP/RFQ requirements.
- Critical worker certification levels (i.e., welding, electrical, CNC, etc.).

- Calibration program review.

4. Manufacture, Assembly, and Inspection Requirements

4.1. Manufacturing Planning / Traveler

Unless otherwise instructed, the supplier shall create planning for each manufacturing job which identifies the following components. This planning shall be available for review by LIGO before, during, or after manufacturing.

- The schedule of operations, including the type of process to be performed (ie, mill, lathe, deburr, outside processing, etc.)
- Machinist sign-off and date, including quantity conforming and non-conforming
- Identification and definition of the inspection points during the manufacturing process
- Inspector sign-off and date, including quantity conforming and non-conforming
- Identification of process specifications, as applicable, for internal and external processes
- Identification of operational constraints, as appropriate (ie, no abrasive metal removal techniques for parts destined for Ultra High Vacuum use.)

4.2. First Article Inspection

LIGO may wish to witness or inspect the First Article part before the rest of the order is completed. The requirement for this will be defined on the Statement of Work if applicable.

4.3. In-Process Inspection

In-process inspections shall be performed where subsequent assembly stages will prevent/limit inspection access, and to detect defects early in the process. In-process inspections shall be identified in the manufacturing planning (see Section 4.1 above).

4.4. Final Inspection

The Supplier shall conduct a Final Inspection of all component parts and assemblies to verify completion and conformance of the following items:

- Conformance to all applicable drawings, SOW, and specifications.
- End Item Data Package review (refer to SOW for complete list)
- LIGO property control documentation, when LIGO materials are in possession of a supplier.
- Evidence of safety requirements compliance, if applicable.
- Shipping documentation such as the manifest or shipper.
- Verification of the adequacy of the shipment packaging and weather protection.
- Verification that transportation environmental controls and monitoring requirements will be satisfied.

4.5. Source Inspection

Source inspection by LIGO personnel may be required. The supplier will be notified of this in advance of shipping the components.

4.6. Discrepant Material

Discrepant parts must be identified and segregated immediately upon detection. If the discrepant parts are required to complete an order and the parts can be reworked to comply with the drawing and/or specifications and with no effect on the delivery date

then LIGO does not need to be notified. If the parts can be reworked to comply with the drawing and/or specifications but the rework process will adversely affect the delivery date, then the LIGO Contracting Officer must be notified.

Please immediately contact LIGO to discuss discrepant parts that cannot be reworked to comply with the drawing and/or specification. Suppliers should use the LIGO form [Q110001 Request for Deviation](#) to formalize a request to submit or rework discrepant parts which will not comply to the drawing and/or specifications. Email the completed form to quality@ligo.caltech.edu for a disposition.

The supplier must retain records of any rework processes as part of the job traveler package.

4.7. Drawing and Specification Change Control

All drawings and specifications will be controlled by the suppliers Quality Assurance Department, including receipt and distribution. Upon receiving the order/contract, all drawings will be verified as to correct number and revision.

Controlled documents must be kept updated at every document change or engineering change. The contract administrator under the guidance of QA will insure that all controlled documents, whether in house or out, will be updated.

Occasionally, LIGO may need to revise drawings for design or manufacturing reasons after the purchase order has been issued. These changes are normally discussed with the supplier in advance of official notification to come to a common agreement on the feasibility and implications of the desired changes. When the change will have no adverse effect on the cost or delivery of the part(s) then a Technical Directive Memorandum will be issued by LIGO to formally document the change. If the change is estimated to affect either cost or delivery of the part(s), then a Change Request will be initiated and sent to the supplier, followed by a revised Purchase Order.

Upon receipt of drawing and specification changes, the supplier Quality Assurance or other appropriate personnel will remove obsolete drawing and/or specifications and issue the latest drawing and/or specification to proper personnel. Obsolete drawings shall either be marked "obsolete" if needed for records or destroyed.

4.8. Welding Certifications

Suppliers of parts or assemblies requiring welding which will be used in an Ultra High Vacuum environment must refer to LIGO specification [E0900048 Welding Specification for Weldments used within the Advanced LIGO Vacuum System](#). This specification details numerous welding specific requirements. The SOW will state if this specification is invoked for a certain part or order.

4.9. End Item Data Package

The end item data package is the set of required documents to be supplied to LIGO upon delivery of ordered parts or services. Refer to the Statement of Work (SOW) for the complete list of documents to be included.

**Acceptable Quality Level (AQL) for Inspection of LIGO Components**

AUTHOR(S)	DATE	Document Change Notice, Release or Approval
Jeff Lewis, Bob Anderson	2/11/2011	see LIGO DCC record Status

1 Scope

This document defines the number of components to be 100% inspected from a manufacturing lot of a particular size based on a specified AQL number.

2 Definition

The maximum percent defective (or the maximum number of defects per 100 units) that, for the purposes of sampling inspection, can be considered satisfactory as a process average.

3 Procedure**AQL Number**

Lot Size	0.25	0.4	0.65	1.0	1.5	2.5	4.0	6.5	10
2 to 8	*	*	*	*	*	5	3	2	2
9 to 15	*	*	*	13	8	5	3	2	2
16 to 25	*	*	20	13	8	5	3	3	2
26 to 50	*	32	20	13	8	5	5	5	3
51 to 90	50	32	20	13	8	7	6	5	4
91 to 150	50	32	20	13	12	11	7	6	5
151 to 280	50	32	20	20	19	13	10	7	6
281 to 500	50	48	47	29	21	16	11	9	7
501 to 1200	75	73	47	34	27	19	15	11	8
1201 to 3200	116	73	53	42	35	23	18	13	9
3201 to 10,000	116	86	68	50	38	29	22	15	9

* Denotes inspection of entire lot. Acceptance Criteria (C) = 0

Table 1. AQL Inspection Frequency.

Use Table 1. to determine the number of pieces from a manufacturing lot to 100% inspect for a specified AQL number. For example: a lot of 100 parts with an AQL number of 1.0 signifies that 13 parts shall be 100% inspected. With the Acceptance Criteria (C) = 0, then if one feature on one part is found to be non-conforming then the entire lot shall have that feature inspected.

The first and last part of a manufacturing lot must always be inspected.