

NOTES CONTINUED:

5 SCRIBE, ENGRAVE, LASER MARK OR MECHANICALLY STAMP (NO DYES OR INKS) A UNIQUE THREE DIGIT SERIAL NUMBER & REVISION NUMBER ON EACH PART. SERIAL NUMBERS START AT 001 FOR THE FIRST ARTICLE AND PROCEED CONSECUTIVELY. BAG AND TAG PARTS WITH THEIR DRAWING PART NUMBER, REVISION, VARIANT OR "TYPE" (IF APPLICABLE), AND QUANTITY. IF PARTS ARE TOO SMALL TO SCRIBE, BAGGING AND TAGGING ALONE IS SUFFICIENT.
 EXAMPLE (PART): 001-v1
 EXAMPLE (TAG): DXXXXXX-VY, TYPE-XX, QTY: TBD

- 6. APPROXIMATE WEIGHT = 0.031 LB.
- 7. MACHINE ALL SURFACES TO REMOVE OXIDES AND MILL FINISH. USE OF ABRASIVE REMOVAL TECHNIQUES IS NOT ALLOWED. REFER TO LIGO-E0900364
- 8. ALL PARTS SHALL BE MANUFACTURED IN ACCORDANCE WITH LIGO SPECIFICATION E0900364.
- 9. ALL MATERIAL IS TO BE VIRGIN MATERIAL (i.e. NO WELD REPAIRS, PLUGS OR RECYCLED MATERIAL). NO REPAIRS SHALL BE MADE UNLESS APPROVED IN ADVANCE, AND IN WRITING, BY LIGO LABORATORY. REFER TO LIGO-E0900364.

10 ENGRAVE "M2" 2 PLACES

REV.	DATE	DCN #	DRAWING TREE #
v1	9 MAR 2016	NOT RELEASED	-
v2	1 MAR 2017	E1700081-v1	-
v3	11 MAR 2017	E1700081-v2	-

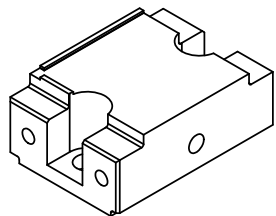
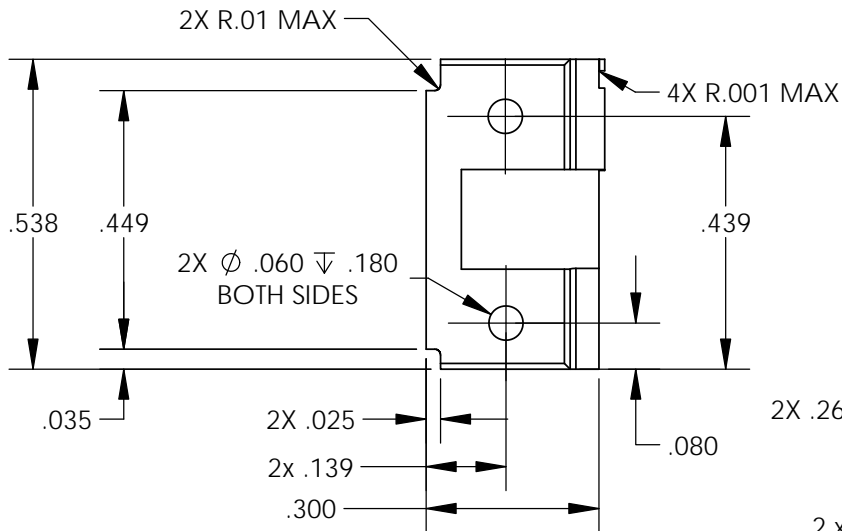

ISOMETRIC VIEW
Scale 3:2

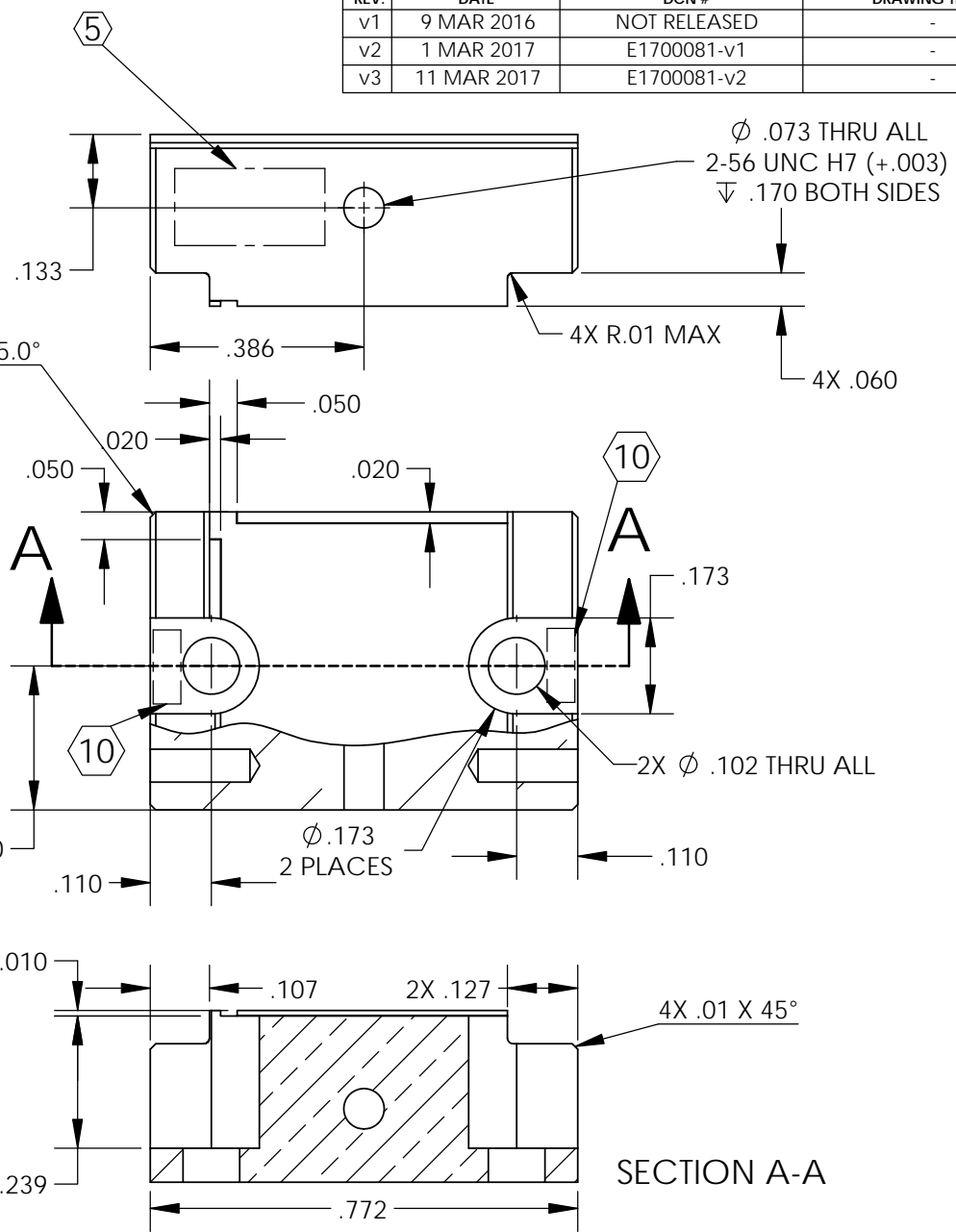

NOTES AND TOLERANCES: (UNLESS OTHERWISE SPECIFIED)

DIMENSIONS ARE IN INCHES

TOLERANCES:
 XX ± .015
 XXX ± .005

ANGULAR ± 0.5°

- 1. INTERPRET DRAWING PER ASME Y14.5-1994.
- 2. REMOVE ALL SHARP EDGES: .005-.015. FOR MACHINED PARTS.
- 3. DO NOT SCALE FROM DRAWING.
- 4. ALL MACHINING FLUIDS MUST BE FULLY SYNTHETIC, FULLY WATER SOLUBLE AND FREE OF SULFUR, SILICONE, AND CHLORINE.

MATERIAL: Copper 110 (Half-Hard)
 FINISH: 32 μinch

LIGO CALIFORNIA INSTITUTE OF TECHNOLOGY
 MASSACHUSETTS INSTITUTE OF TECHNOLOGY

SYSTEM: ADVANCED LIGO
 SUB-SYSTEM: SQZ
 NEXT ASSY: D1500300

PART NAME			SIZE		DWG. NO.	REV.	
Pelletier Bottom Bracket			A		D1600066	v3	
DESIGNER	F. Matchard	9 MAR 2016	CHECKER	F. Matchard	9 MAR 2017	APPROVAL	C. Torrie
SCALE: 3:1			PROJECTION:		SHEET 1 OF 1		