

# RF Leakage Studies & GPS Signal Jitter Analysis

John Schaefer

Mentor: Dick Gustafson and Keita Kawabe

October 14, 2017

## Abstract

RF signals are mainly responsible for putting the interferometer into lock, an important task that allows LIGO to be sensitive enough for gravitational events. However, RF signals can cause leakage that can interfere with other electronics. One culprit is DC ground isolation units. When performing a spectrum analysis using an RF analyzer and measuring cabling ground to cabling ground, it was found that there were significant signal leakages as high as 80 mV when it should ideally be 1 mV. Upon investigation and testing, it was determined that the leakages were due to small or absent capacitance along the units enclosures. After modifying the capacitance of the units and then testing for insertion loss and phase delay, an order of magnitude decrease in RF leakage was observed.

Timing, from both GPS and a cesium clock, is another important aspect of LIGO which dictates much of how measurements are taken. When several atomic clocks are tuned to be in phase with each other and triggered on a 1 PPS GPS signal, the clock signals jitter on the order of nanoseconds. Given that this is tested against multiple clocks, GPS must be the source of the jitters. This may not have a large effect on short term measurements, but for long term integrations such as continuous wave searches, this error may become a problem. After long term data acquisition and analysis, it was found there were distinct periodicities in the jitter. Further analysis was also done to determine whether these jitters were random or deterministic.

# 1 Introduction

The Laser Interferometer Gravitational-Wave Observatory (LIGO) is an experiment dedicated to the detection of gravitational waves. LIGO utilizes large-scale Michelson interferometers (IFOs) located in Hanford, Washington and Livingston, Louisiana. These IFOs have arms that are 4 km long that are oriented at right angles from each other. With a laser beam split to travel down the two arms and back, the interference pattern created by the rejoined beams tells us whether there are any differences in lengths between the two arms. In the presence of a gravitational wave, one the arms will contract and the other will extend due to the perturbation in space-time. Due to the nature of gravitational waves, even some of the universe's strongest waves (from binary black hole mergers) can only create differences in length on the order of  $10^{-19}$  m. This is about one ten-thousandth the size of a proton.

Detecting such an incredibly small fractional change requires an incredible amount of noise reduction. Sources of noise that are accounted for include seismic activity, building tilt due to wind, and vibrations in the fibers that suspend test masses. My two projects for the summer have also focused on noise reduction at the LIGO Hanford Observatory.

The first of these projects focuses on investigations of radio frequency (RF) leakage in the RF source cabling. These leakages have been suspected to be an underlying cause of frequent losses of laser lock. The main culprit investigated was our DC ground isolation units, or baluns. As the name implies, these devices are used to decouple DC grounds to prevent noise from appearing in the data. This was done through the use of a transformer. However, the transformer was not perfect and was prone to leaking RF signal. Thus, these baluns included a shield that RF shorts along. To keep the grounds from coupling, high-pass filters were applied to the shield. However, after measurement across cabling grounds, it was seen that the RF shields were far from perfect.

The second of these projects was investigation into the wandering in one of our atomic clocks in relation to a GPS 1 pulse per second (PPS) control system. GPS timing signal is important for making measurements with the interferometer. When taking several atomic clocks in tune with each other and triggering their signals against the 1 PPS GPS signal, it was seen that all of the signals were jittering in phase. Since all of the atomic clocks were tuned together, this meant that it was GPS that was jittering.

# 2 Methods

There have been several trips to the Laser and Vacuum Equipment Area (LVEA) with the purpose of investigating RF leakages. Using an Agilent 4396B RF Analyzer, spectrum analyses were performed on baluns mounted on the electronics racks. Measuring cabling ground to cabling ground across the balun, rather large RF leakages were observed with the largest peaks seen at frequencies supplied by the voltage control oscillator (VCO) that respective baluns were mounted on. One of the highest peaks observed was about -22 dBV at 80 MHz. In an attempt to fix this, several modifications were made on the baluns. With these modified baluns, performance tests were done which included measuring the loss in leakage for a replaced balun as well as its neighboring balun by comparing the spectrum before and after.

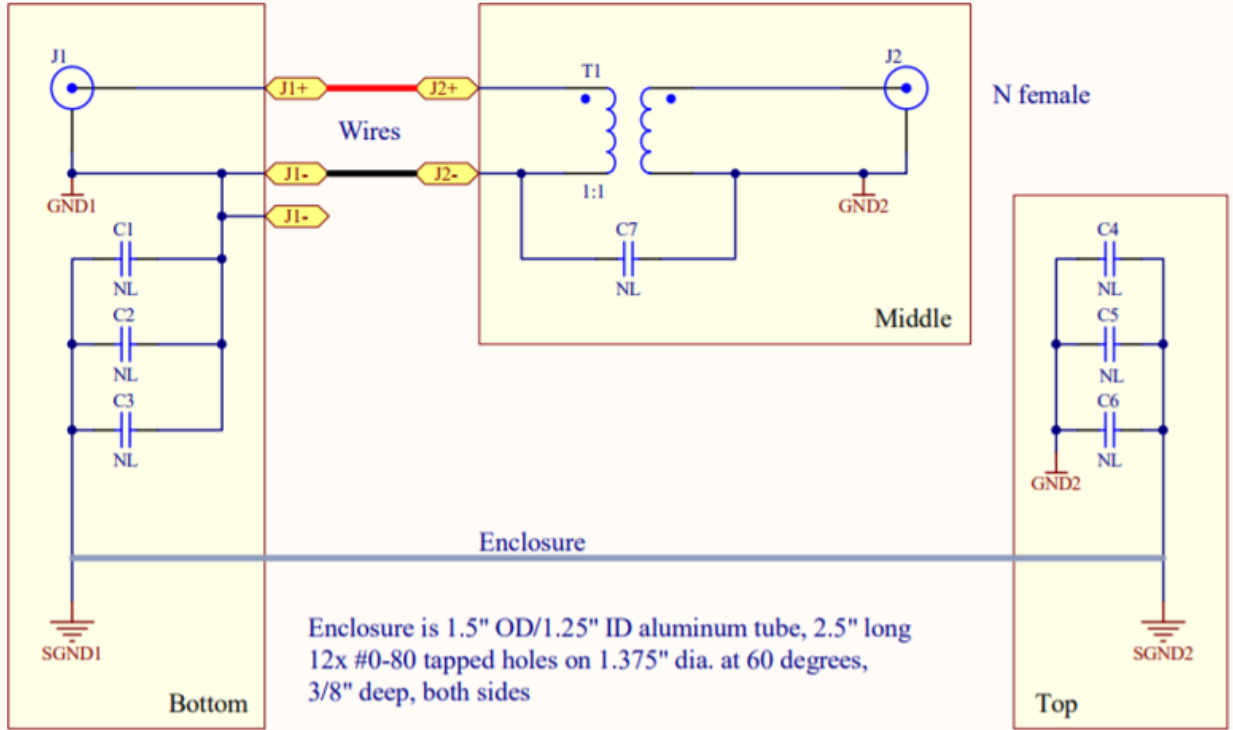

Figure 1: Balun circuit diagram (LIGO-D1101077-v2).

The modifications made were ultimately pertaining to the capacitance along the enclosure. From Figure 1, we can see that there are two groups of three 10 nF capacitors on either end of the balun. The individual groups are in parallel with each other giving an effective capacitance of 30 nF on each side. The problem is that the two groups are in series giving an overall effective capacitance of 15 nF. The latest version of this diagram does not have any capacitors on it. We want a large capacitance so that the voltage difference between the cabling grounds on either side of the balun becomes minute, reducing the RF leakage. This comes from the fact that the impedance  $Z$  of a capacitor in an AC circuit is  $Z = 1/(i\omega C)$  where  $\omega$  is the angular frequency of the oscillating voltage supply and  $C$  is the capacitance. The higher  $C$  is, the smaller  $Z$  is. And thus, the voltage difference is decreased as well by Ohms Law. The modifications made includes replacing one of the plates of three capacitors with a copper plate, a conducting material. This alone increases the effective capacitance to 60 nF. Then, the remaining plate was loaded with more capacitors placed in parallel with the existing ones, thereby increasing the capacitance even more. The decrease in leakage mentioned above was the result of adding three 1 F capacitors in parallel with the existing 10 nF ones. So far, baluns with three and five 47 F (20% tolerance) capacitors have been modified and tested.

Before testing these modified baluns on the electronics racks in the LVEA, the baluns were first tested to ensure that they were all within specification as detailed in the testing procedures (LIGO-E1100597-v2). The procedure consisted of measuring the transfer function of the balun and comparing it with the transfer function with a barrel in place of the balun. The parameters considered were insertion loss and phase delay. According to the procedures, only insertion losses of less than 3 dB and magnitude of 5 deg phase delay was allowed for frequencies ranging from 200 kHz to 100 MHz.

To measure the jitter in phase, a 5 MHz signal from a Model FS725 Rubidium Frequency Standard was triggered on the 1 PPS GPS signal. This was measured using a Tektronix TDS 3034C Digital Phosphor Oscilloscope. Since data from the atomic clock signal was captured once per second, there was a need to save the data for every capture. A Matlab program was then written to record data from the oscilloscope every second and determine the phase displacement. This was done using MatLab's Instrument Control Toolbox which sent commands from a computer to the oscilloscope using a VISA connection via Ethernet. The data was taken over the course of about 25 hours.

### 3 Results

As detailed in the methods section, the insertion loss and phase delay was measured according to the testing procedures (LIGO-E1100597-v2) and then compared to balun specifications (LIGO-T1100369-v1).

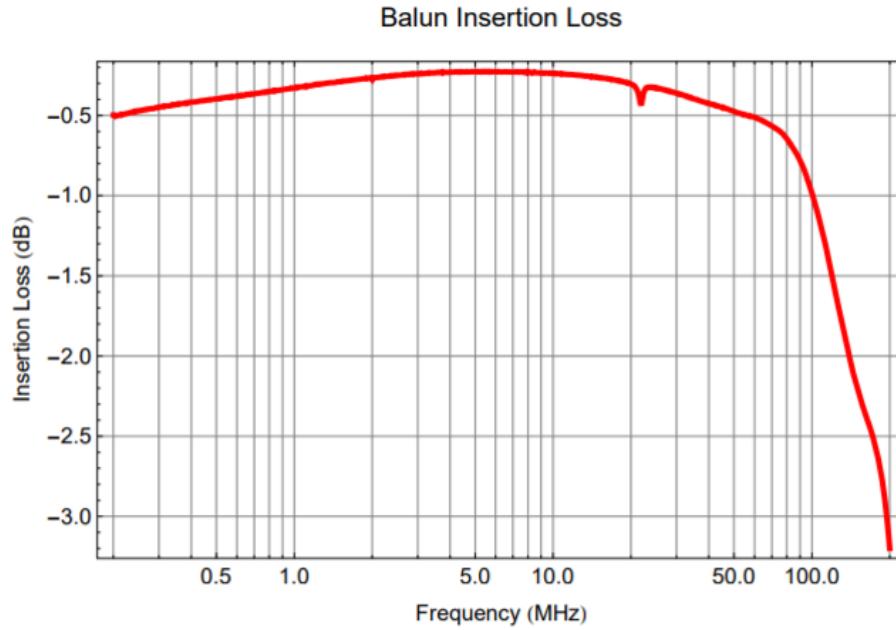

Figure 2: Balun insertion loss according to specifications (LIGO-T1100369-v1).

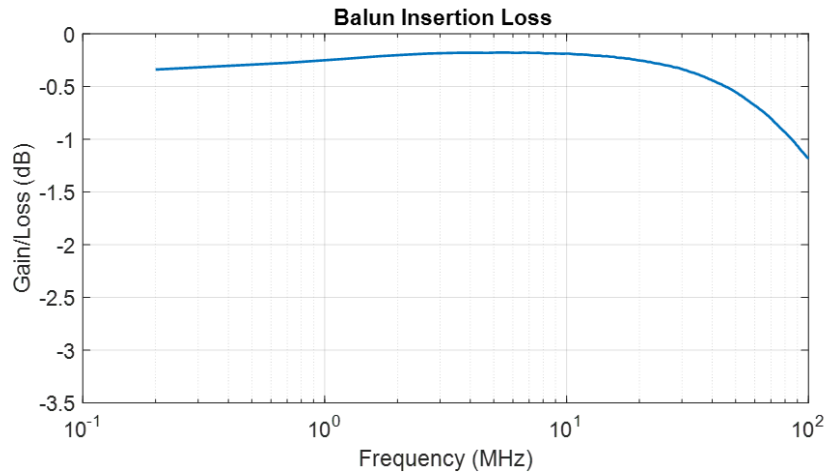

Figure 3: Insertion loss of modified balun.

From Figure 2 and 3, one can see the insertion loss of the modified was within 3 dB for frequencies between 200 kHz and 100 MHz.

Next, the results for the phase delay measurement was obtained according to the testing procedures (LIGO-E1100597-v2) and then compared to balun specifications (LIGO-T1100369-v1).

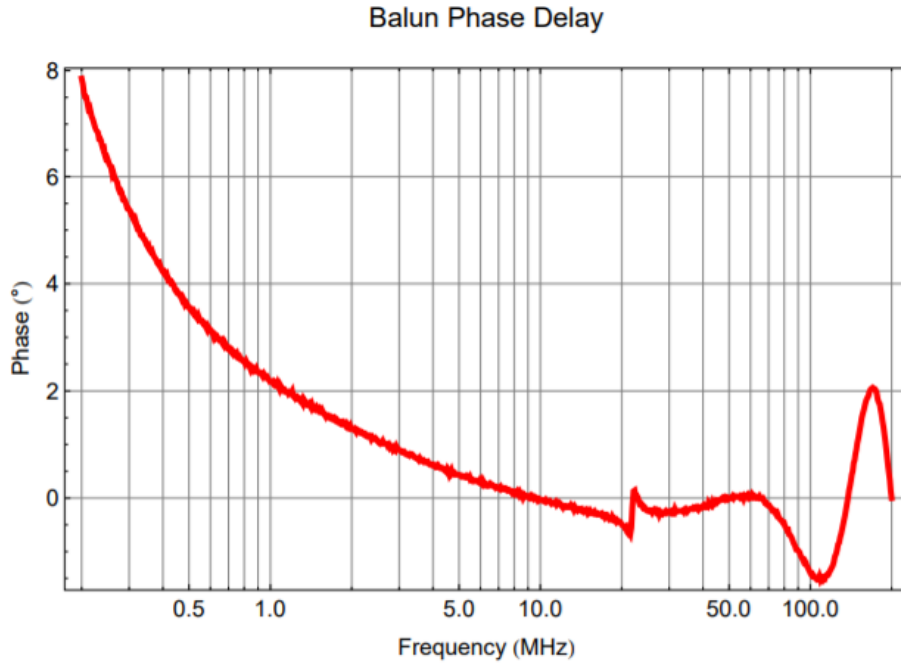

Figure 4: Balun phase delay according to specifications (LIGO-T1100369-v1).

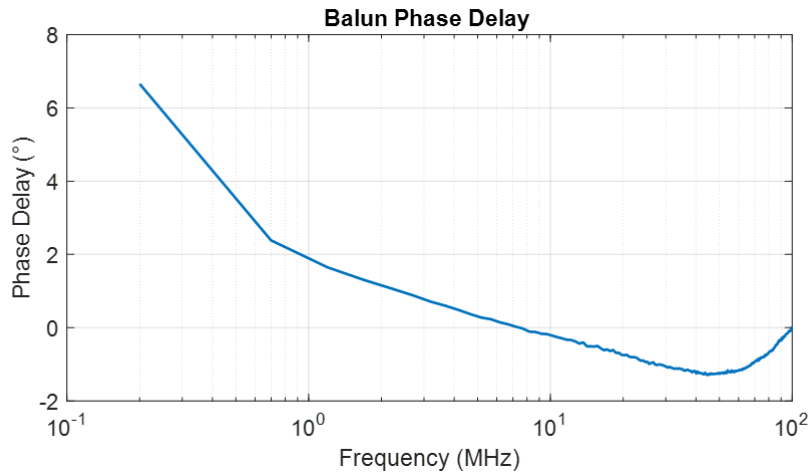

Figure 5: Phase delay of modified balun.

Like with the insertion loss, the modified baluns were within specifications for phase delay. From Figure 4 and 5, one can see the phase delay magnitude was within 5 deg.

With the baluns tested, the modified baluns were tested on the electronics racks in the LVEA. When replacing a balun carrying an 80 MHz signal, a drop in leakage of a factor of more than 250 was observed. This was a significant drop in leakage. Comparing the spectra before and after from the replaced balun and its neighbor yielded more interesting results.

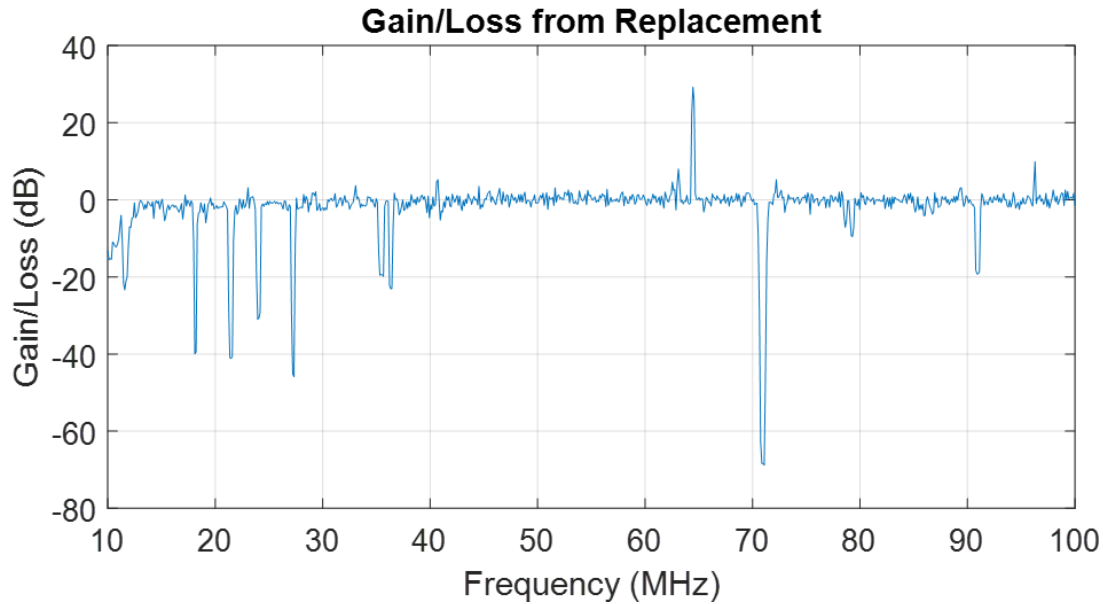

Figure 6: Gain/loss in leakage from replacing balun carrying 71 MHz signal with modified balun.

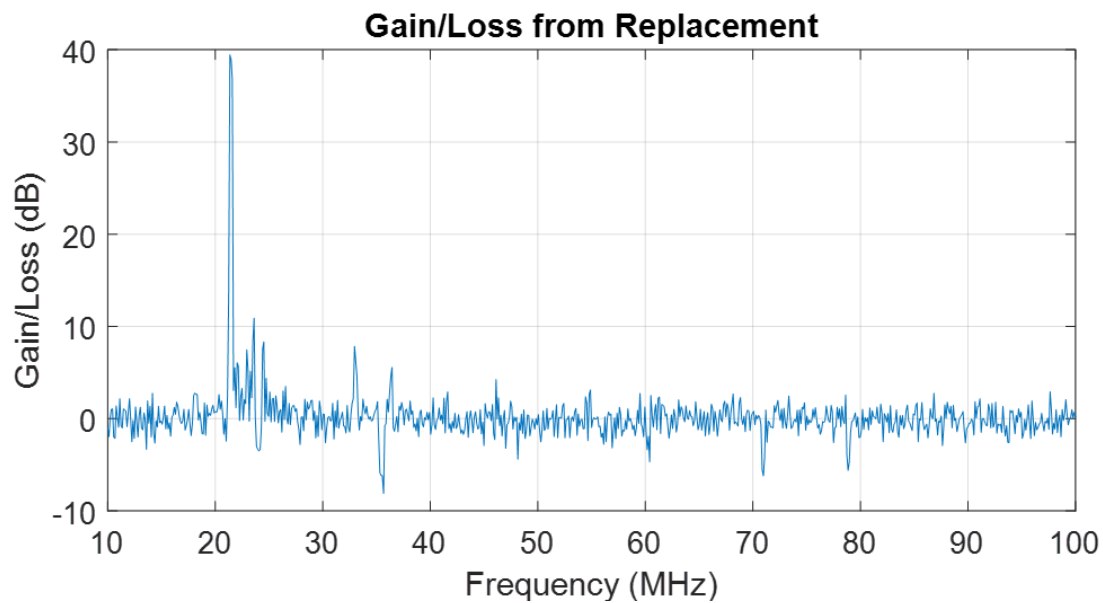

Figure 7: Gain/loss in leakage from replacing neighboring balun carrying 71 MHz signal with modified balun.

From Figure 6, one can see that there was a significant loss in leakage (about 75 dB) at about 71 MHz (the frequency carried) from replacing the balun with a modified one. There were several other losses, but what was interesting was that there were a couple small gains at different frequencies. From Figure 7, one can see that although there was a loss in leakage at 71 MHz in a balun neighboring that of the replaced balun, there was significant gains in leakage seen at lower frequencies.

As for the phase jitter analysis, data was taken over the course of about 25 hours. Due to the small difference in frequency between the atomic clock and GPS, a mean linear phase drift was expected. It was the residuals of the linear fit that was more interesting.

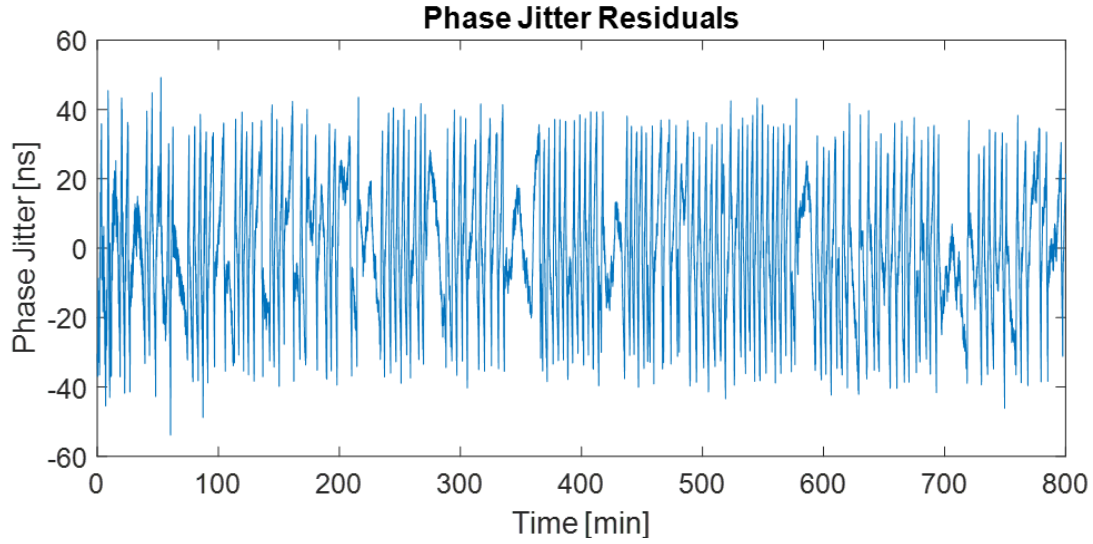

Figure 8: Phase jitter residuals from first 800 minutes of 25 hours of data acquisition.

From Figure 8, one can see that there seemed to be a periodic nature to the residuals. From this data, a periodogram was calculated which gave an idea of the periodicities underlying the residuals.

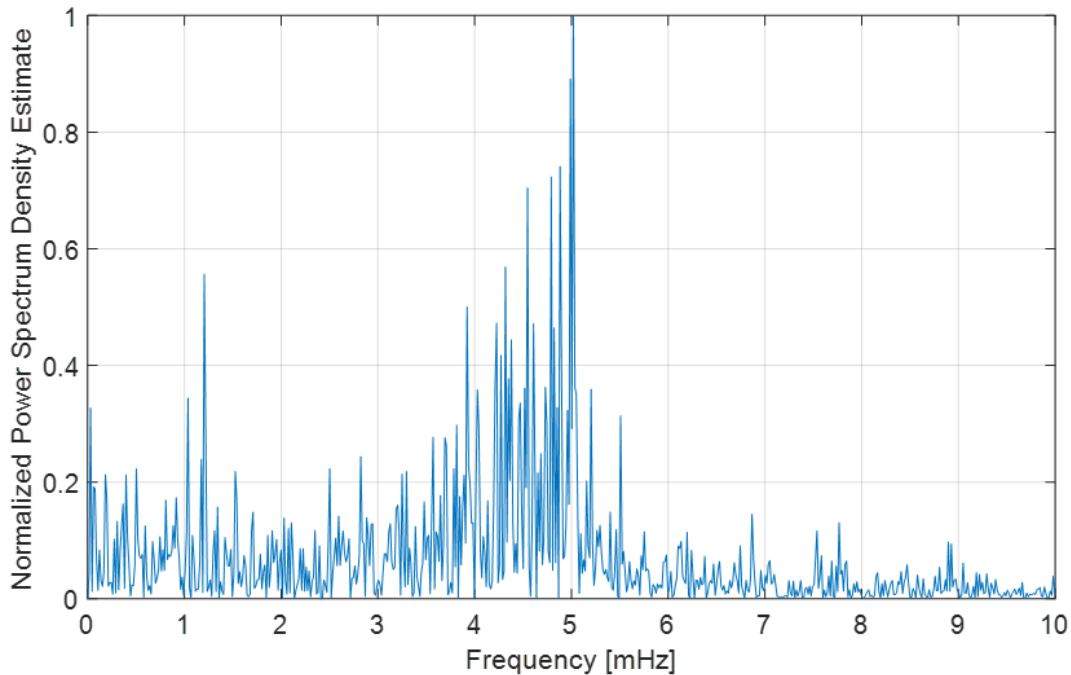

Figure 9: Periodogram of phase jitter residuals.

From Figure 9, one can see that there were two prominent groups of peaks. The one with the highest peaks has a maximum peak at 5.02 mHz. The smaller one has a highest peak at about 1.205 mHz. This periodogram suggested that there was an underlying periodicity associated with the phase jitter.

Another observation that was made, was the randomness of the jitter. From basic noise analysis, one can infer that the jitter was from random fluctuations if the noise was Gaussian.

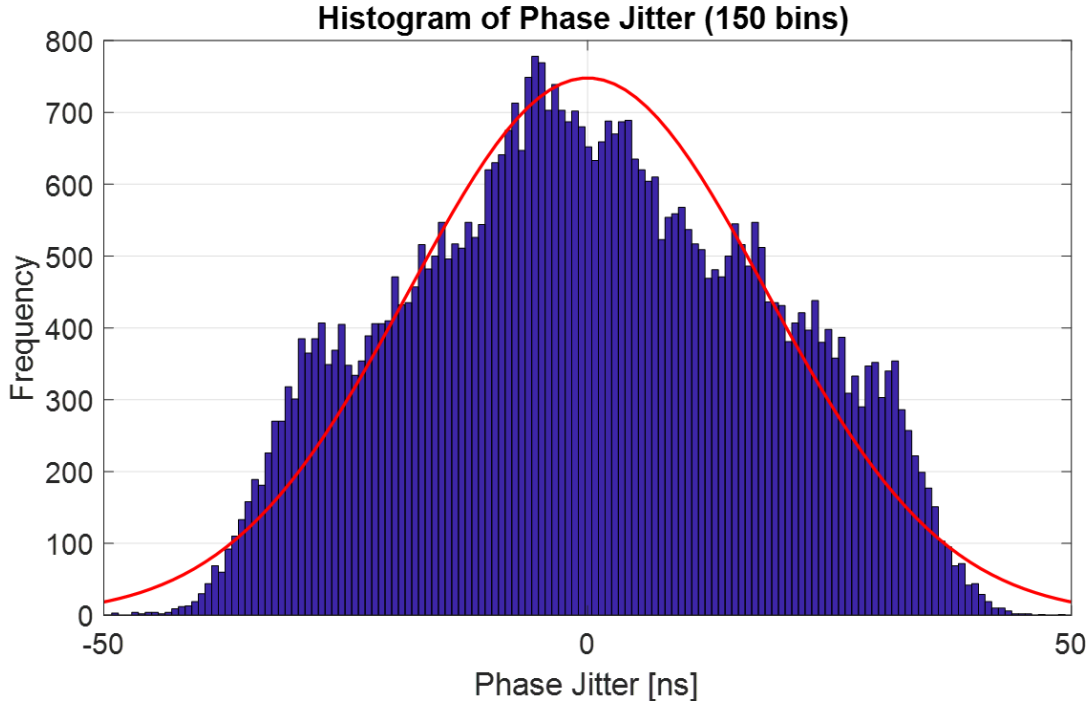

Figure 10: Histogram of phase jitter residuals with Gaussian fit.

From Figure 10, one can see that the Gaussian fit did not fit the data very well. This suggested that the jitter was not solely from random noise.

## 4 Conclusions

From the results in the RF leakage project, leakages appeared from various baluns mounted in the LVEA when measuring across cabling grounds. The modifications to the baluns were also seen to create significant losses as much as about 75 dB. However, there appeared to be some unappreciated nuances as to how the leakage propagated as seen by the gains in Figure 7. A more in-depth investigation of the electronics systems would be needed to determine why gains in leakage were seen. It is recommended that more robust solutions to RF leakage be researched as well. Overall, these leakages may indeed be a source of noise for the interferometer that can be readily mended.

From the results of the phase jitter analysis, it was shown that there was indeed jitter in GPS signal phase on the order of tens of nanoseconds. It was also seen that this jitter displayed some periodicity and did not follow a Gaussian distribution which suggested the jitter to be nonrandom in cause. Although the jitter's status as noise was not determined during the course of this project, it is recommended that careful investigation of the timing electronics be done to discern the source of the jitter.

## 5 Acknowledgments

First and foremost, I would like to thank my mentor Dick Gustafson for teaching me so much about electronics over the course of 10 weeks. I would like to also thank his wife, Mary, for taking care of me my first week in the Tri-cities. I want to thank everyone in the electronics lab for answering my trivial questions multiple times a day. Last, I want to thank everyone at LIGO Hanford Observatory for all that they helped me with, in one way or another.