



# Constructing a Balanced Homodyne Detector For Low Quantum Noise Gravitational Wave Interferometry

John Martyn, LIGO SURF 2018

Mentors: Andrew Wade, Kevin Kuns, Aaron Markowitz, Rana Adhikari

Caltech, LIGO

August 23, 2018

# A Brief Discussion of Noise

- Given a signal,  $y(t)$ , as a function of time, the noise spectral density of the signal,  $N_y(f)$ , is defined by

$$N_y(f) := \lim_{T \rightarrow \infty} \frac{2}{T} \left| \int_{-T/2}^{T/2} dt (y(t) - \bar{y}) e^{2\pi i f t} \right|^2$$

- This obeys
 
$$\int_0^\infty df N_y(f) = \sigma_y^2,$$
 and allows one to examine what frequencies contribute to a signal's variance.

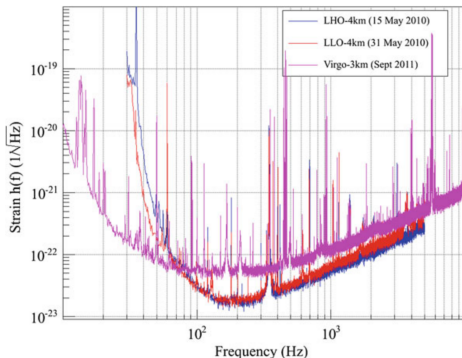

# Sources of Noise

## Sources of noise at LIGO:

- Extrinsic
  - Weather, human activity, electronic noise, etc.
  - Reduced by performing interferometry in vacuum chambers, vibration isolation systems, low noise circuits, etc.
- Intrinsic
  - Arises from the laws of quantum mechanics
  - Quite nontrivial to reduce

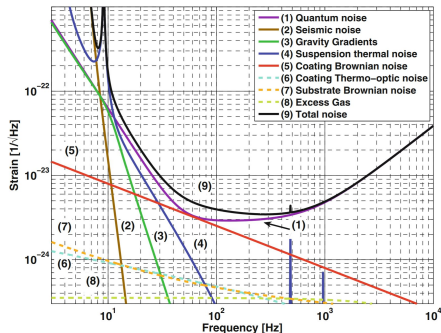

# Quantization and Noise

A source of noise, known as quantum noise, contributes to intrinsic noise that LIGO must combat.

- Due to quantum mechanics
- Recall the quantization of a mechanical system:

$$[\hat{x}, \hat{p}] = i\hbar \Rightarrow \sigma_x \sigma_p \geq \hbar/2 \quad (1)$$

- Nonzero uncertainties introduce noise into  $x$  and  $p$ 
  - For instance,  $\sqrt{\int_0^\infty df N_x(f)} = \sigma_x \neq 0 \Rightarrow N_x(f) \neq 0$

# EM field

How does this affect LIGO?  $\Rightarrow$  the light in the interferometer  
First consider a monochromatic plane wave:

- Its electric field:

$$\hat{\mathbf{E}}(\mathbf{r}, t) = E_0 \left( \hat{X}_1 \cos(\omega t) - \hat{X}_2 \sin(\omega t) \right) \mathbf{p}(\mathbf{r}, t)$$

$E_0 =$  amplitude,  $\mathbf{p}(\mathbf{r}, t) =$  polarization

- $\hat{X}_1$  and  $\hat{X}_2$ , the amplitude and phase quadratures, furnish a description of the wave.
- We wish to measure these quadratures to perform interferometry.

# Quantum Noise

- Unfortunately, quantum noise introduces shot noise and radiation pressure noise into monochromatic plane waves (by quantizing EM field).
- Quadratures become  

$$X_{1,2} = \text{classical field} + \text{noise} = X_{1,2}^0 + x_{1,2}$$
- This poses a serious difficulty for gravitational wave interferometers using monochromatic plane waves.

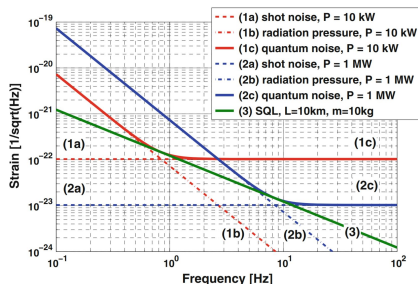

# Balanced Homodyne Detection

- Luckily, balanced homodyne detection (BHD) can accurately measure an arbitrary quadrature of light.
- BHD works by mixing a strong source of light known as the local oscillator (LO), with a weak signal (modulated light), and sending the combined light through a beam splitter.
- The signals exiting the beamsplitter are then subtracted, producing the homodyne signal.

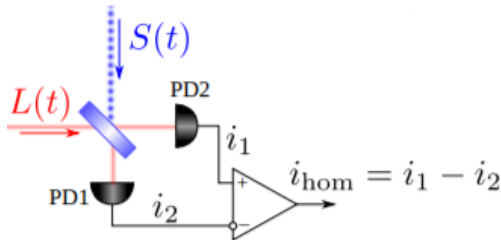

# Balanced Homodyne Detection

- $S_{c,s}(t)$  and  $L_{c,s}(t)$  (quadratures) contain effects due to quantum noise:

$$S_{c,s}(t) = S_{c,s}^0(t) + s_{c,s}(t), \quad L_{c,s}(t) = L_{c,s}^0(t) + l_{c,s}(t)$$

- We assume the local oscillator (LO) is more intense than the other fields:

$$L_{c,s}^0(t) \gg S_{c,s}^0(t), \quad s_{c,s}(t), \quad l_{c,s}(t)$$

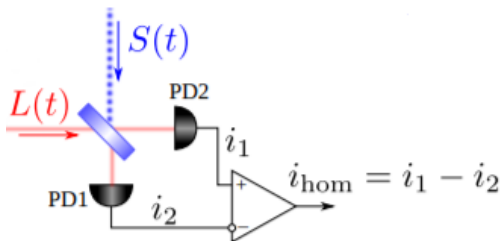



# Balanced Homodyne Detection

- Local oscillator (LO) is more intense than the other fields:

$$L_{c,s}^0(t) \gg S_{c,s}^0(t), s_{c,s}(t), l_{c,s}(t)$$

- Homodyne current: (Danilishin, Khalili, arXiv:1203.1706)

$$i_{\text{hom}} = i_1 - i_2 \propto L_c^0(S_c + s_c) + L_s^0(S_s + s_s)$$

- LO noise cancels out!  $i_{\text{hom}}$  depends only on signal noise.

- Can measure arbitrary quadratures  $\Rightarrow$  more information than LIGO's DC readout scheme
- Useful for experiments with squeezed light

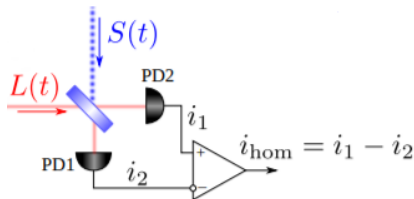

# The Goal

- The goal of this project is to construct the optical components and readout electronics for a balanced homodyne detector that may be used in various LIGO research labs performing experiments with non-classical light.

# Optics

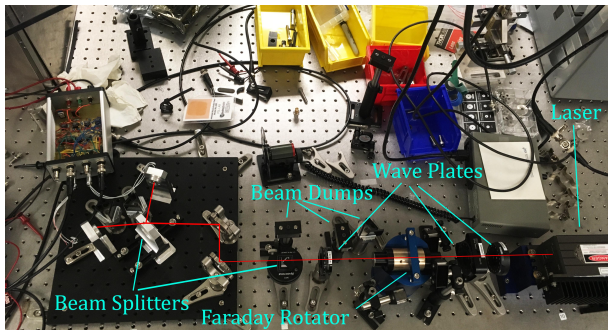

- Laser emits 1064 nm TEM<sub>00</sub> Gaussian mode
- Wave plates and Faraday rotator for power control.
- Steering mirrors for proper alignment

# Photodiodes

- Our BHD readout uses Laser Components InGaAs PIN photodiodes.
  - Model Number: IG17X3000G1i
  - 3 mm diameter
  - 1.55 nF capacitance
- We must characterize these to ensure they will perform well in the detector.

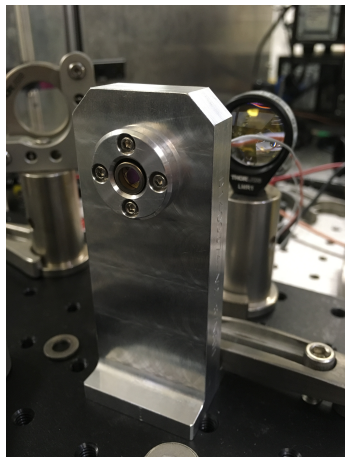

# Photodiodes

- Measured current to voltage transfer function at two different powers.
- Large gain, independent of power, displays roll off with corner frequency  $f_c \approx 300$  kHz.

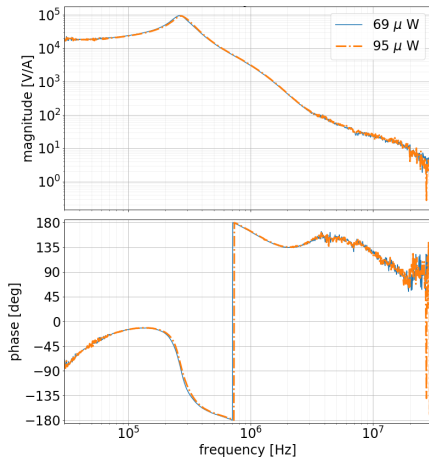

# Circuit Design

- Created two circuits (one for each photodiode), which feature buffers, AC and DC output, and differential output:

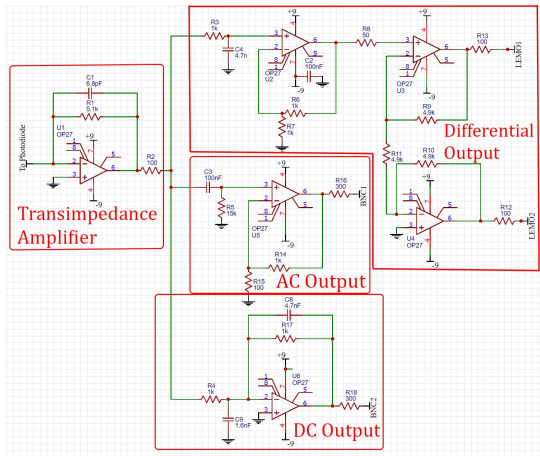

# Circuit Design

- Powered by 9V batteries
- Inputs from photodiode come from LEMO connectors that I attached to the photodiode
- Outputs are sent to BNC and LEMO connectors

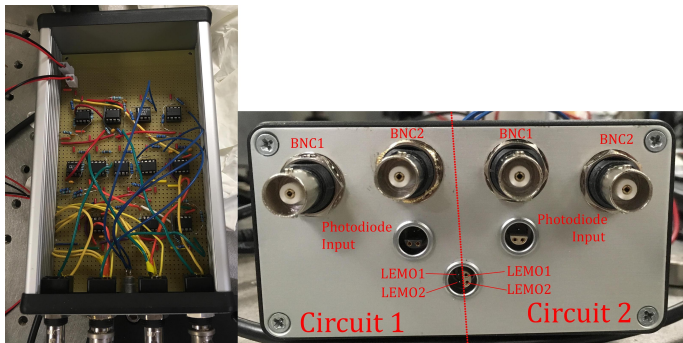

# ADC and Digital Subtraction

- Attached circuit inputs to photodiodes and performed subtraction via SR785 performed well
- Signals were discernible and noise reduced to noise floor
- Digital subtraction is more robust  $\Rightarrow$  connected DC outputs to an analog-to-digital converter

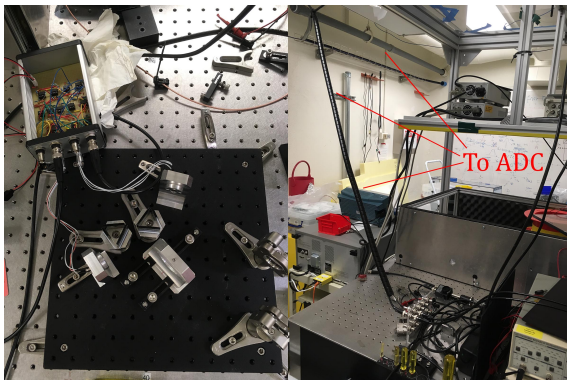

John Martyn

Constructing a Balanced Homodyne Detector



# ADC and Digital Subtraction

- As a test, I sent in AC (amplitude modulated) and DC signals from the laser and collected data from the ADC with a python script
- Homodyne readout was achieved by subtracting the data from the two photodiodes in appropriate quantities via a Jupyter notebook:
  - homodyne signal =  $H = \alpha(D_1 - \beta D_2)$
  - $\alpha$  = ADC counts to volts,  $\beta$  = relative gain,
  - $D_{1,2}$  = photodiode data from ADC (measured in counts)

# Measurements

- ADC noise is high, making it hard to discern a signal
- Likely a transmission of configuration issue

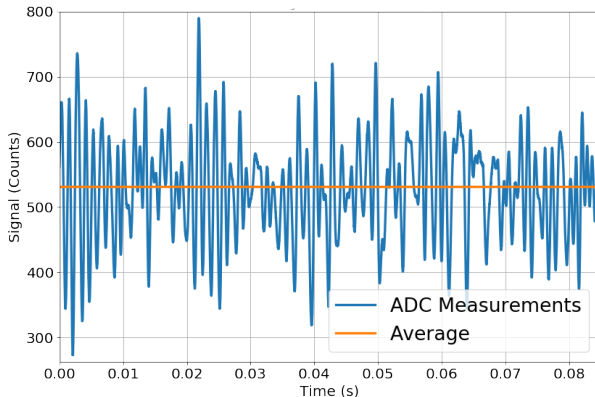

# Current Work

- Make changes to circuit to reduce noise (voltage regulators, shunt capacitors, new op amps)
- Some noise measurement agreement is fair, others is not
- Possible short circuit when changes were made?

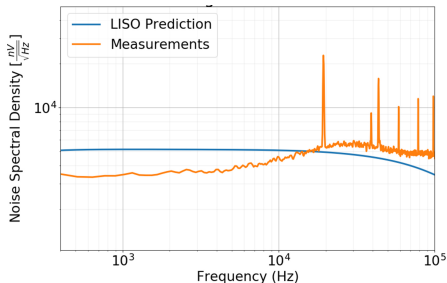
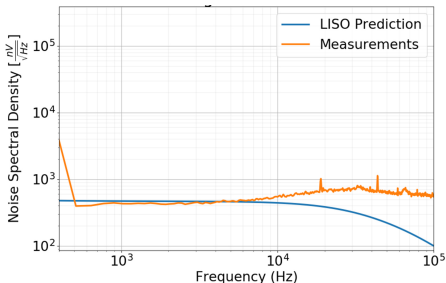

# Future Work

- Optimize noise
  - Use new op amps (OP37's in the mail!)
  - Reduce ADC noise (improve signal transmission to ADC (15m away), check configuration, use differential output)
- Use BHD setup in an interferometer or experiment

# Thank You

Thanks to:

- Andrew, Kevin, Aaron, Rana
- Johannes, Tom, Anchal, Gautam, Vinny, Koji, Aidan
- Caltech LIGO collaboration
- LIGO SURF

# References

- [1] A. I. Lvovsky, *Squeezed Light*. ArXiv e-prints (2016), arXiv:1401.4118v2 [quant-ph].
- [2] A. Zangwill, *Modern Electrodynamics*. (2013)
- [3] B. P. Abbott et al., *Observation of Gravitational Waves from a Binary Black Hole Merger*. Phys. Rev. Lett. **116**, 061102 (2016).
- [4] C. W. Misner, K. S. Thorne, and J. A. Wheeler, *Gravitation*. (1973).
- [5] H. Grote, et. al., *High power and ultra-low-noise photodetector for squeezed-light enhanced gravitational wave detectors*. Opt. Express, **24**, 20107-20118 (2016).
- [6] H. Kogelnik and T. Li, *Laser Beams and Resonators*. Appl. Opt. **5**, 1550-1567 (1966)
- [7] H. Miao, *Exploring Macroscopic Quantum Mechanics in Optomechanical Devices*. (2012).
- [8] H. W. Ott, *Noise Reduction Techniques in Electronic Systems*. (1988).
- [9] J. G. Graeme, *Photodiode Amplifiers: Op Amp Solutions*. (1995).
- [10] K. Thorne, *Ph237b: Gravitational Waves*. California Institute of Technology (2002).
- [11] K. Thorne and R. Blanford *Modern Classical Physics: Optics, Fluids, Plasmas, Elasticity, Relativity, and Statistical Physics*. (2017).
- [12] <https://www.ligo.caltech.edu/>
- [13] M. Bassan, et. al, *Advanced Interferometers and the Search for Gravitational Waves*. (2014).

# References

- [14] K. Nakamura and M. Fujimoto *Double balanced homodyne detection*. ArXiv e-prints (2018), arXiv:1711.03713v2 [quant-ph].
- [15] S. L. Danilishin and F. Y. Khalili, *Quantum Measurement Theory in Gravitational-Wave Detectors*. ArXiv e-prints (2012), arXiv:1203.1706v2 [quant-ph].
- [16] S. M. Carroll, *Spacetime and Geometry: An Introduction to General Relativity*. (2004).
- [17] W. Ketterle, *8.422 Atomic and Optical Physics II*. Spring 2013. Massachusetts Institute of Technology: MIT OpenCourseWare, <https://ocw.mit.edu>. License: Creative Commons BY-NC-SA.
- [18] G. Heinzel, NAO Mitaka, *LISO - Program for Linear Simulation and Optimization of analog electronic circuits – Version 1.7*. (1999), [http://www2.mpg.de/~ros/geo600\\_docu/soft/liso/manual.pdf](http://www2.mpg.de/~ros/geo600_docu/soft/liso/manual.pdf).
- [19] H. Hashemi, *Transimpedance Amplifiers (TIA): Choosing the Best Amplifier for the Job*. (2012), <http://www.tij.co.jp/jp/lit/an/snoa942a/snoa942a.pdf>.
- [20] A. Bhat, *Stabilize Your Transimpedance Amplifier*. (2012), <https://www.maximintegrated.com/en/app-notes/index.mvp/id/5129>.