



Third Time's a Charm:

A Status Report from the The LIGO
Detectors during their 3rd
Observation Run

J. Kissel, for the LIGO, VIRGO, and KAGRA Scientific
Collaboration

We are now an observatory

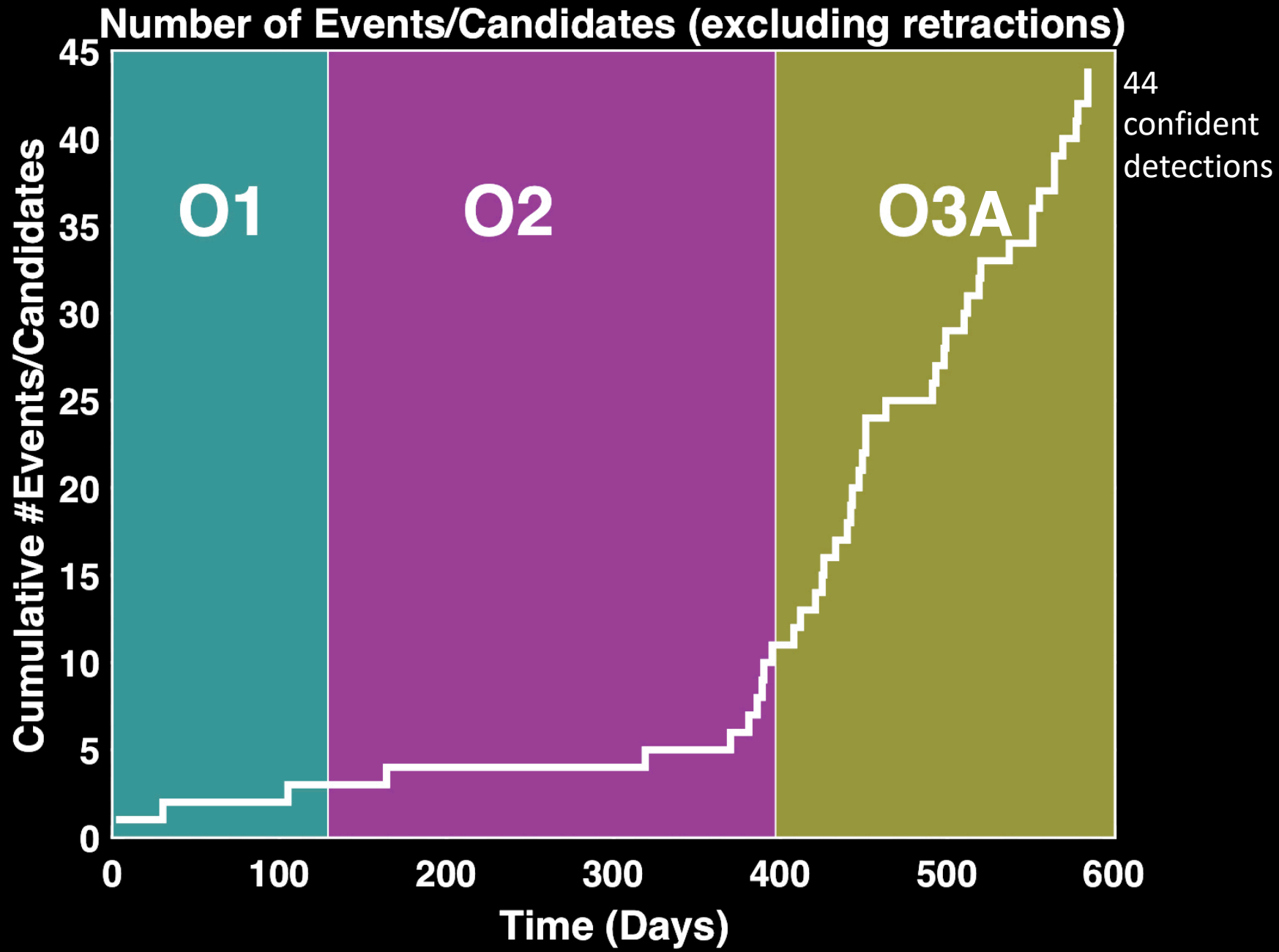

Improved between O2 and O3 at LIGO

- “Downgraded” noisy 180 W laser to quieter 70W laser (only using 35-40W anyways)
- Replaced some test masses
- Now using quantum mechanical tricks to improve phase noise – aka Squeezed Light
- Improved mitigation of “stray light”

The O3 Interferometer

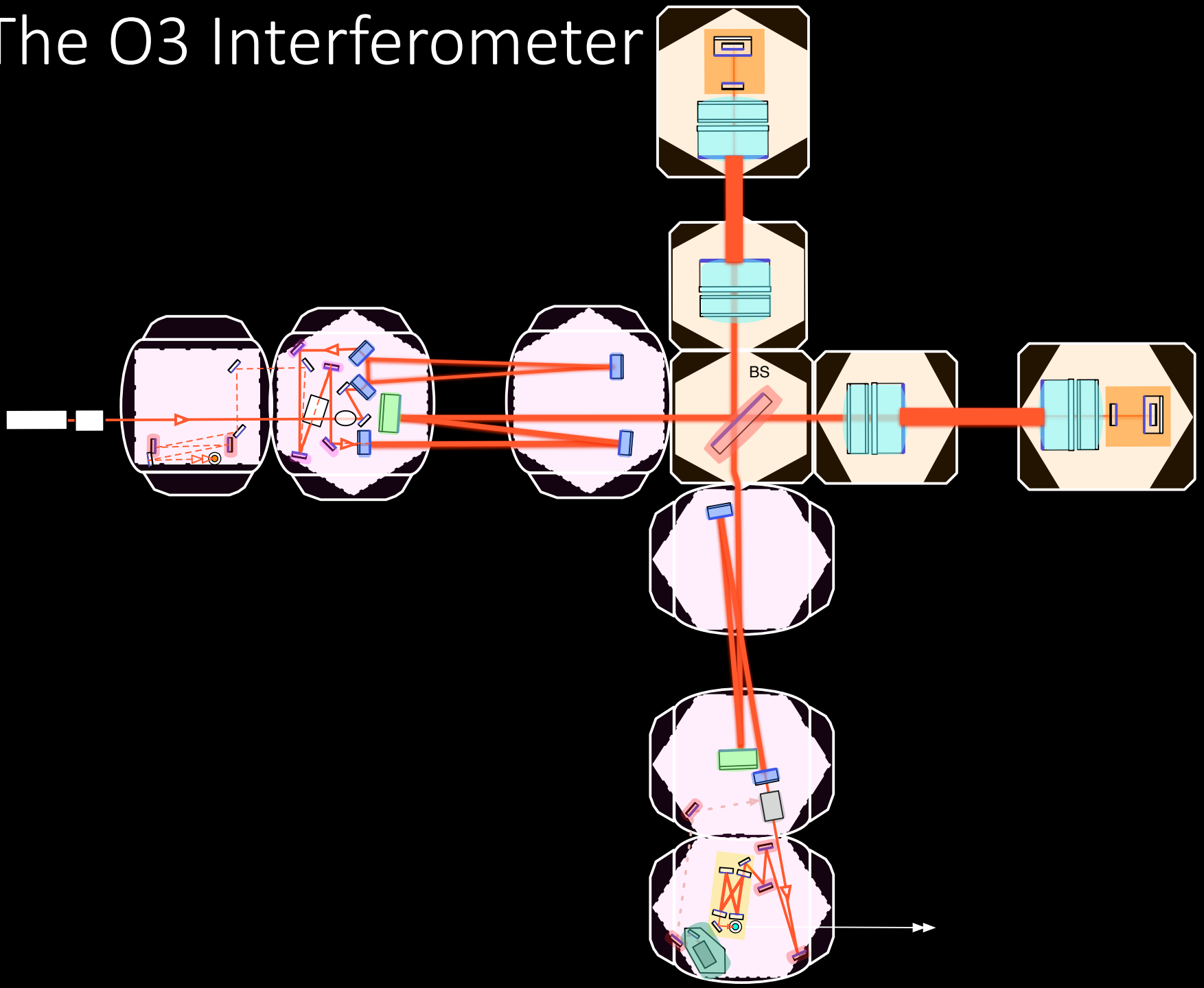

LIGO's Global Partners

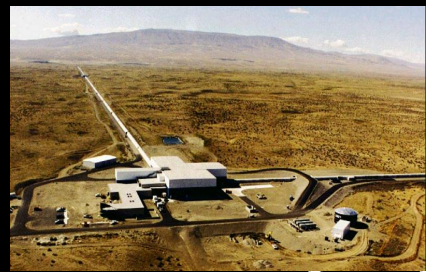

LIGO
Hanford



GEO600



KAGRA



LIGO
Livingston



VIRGO

LIGO India



With a network, you gain directional sensitivity!

Displacement Sensitivity

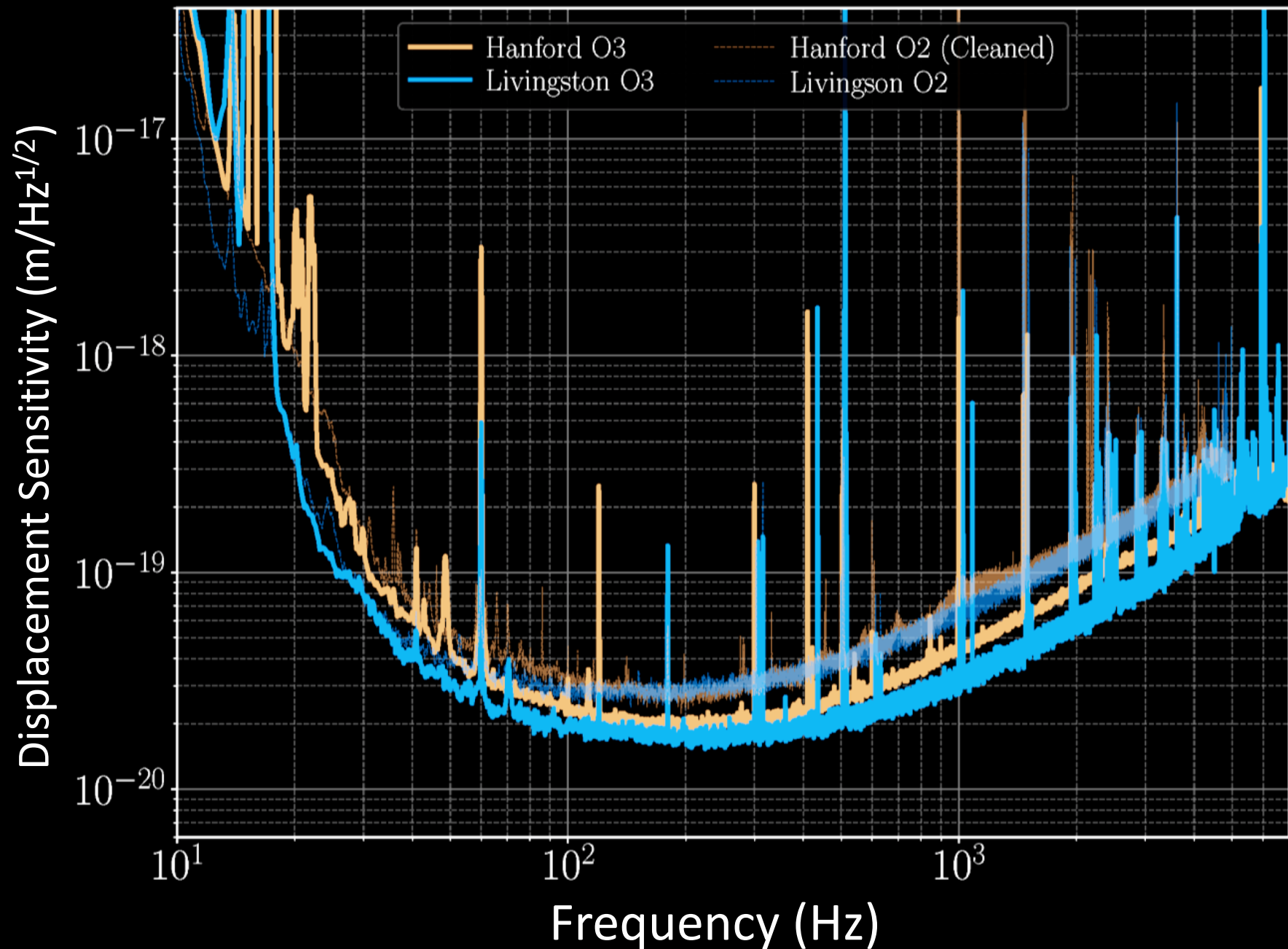

First 6 Months of O3

- 3 detector network:
LIGO Hanford, LIGO Livingston, VIRGO
- Apr 1 2019 to Oct 1 2019 (183 days)
- 3.2% total “dark” time
- Typical BNS Reach: (see next slide)
- 41 GW-only event candidates announced to the public in low latency
- **33 candidates still considered viable!**

Astrophysical Results



“Chirp” gravitational wave app

Available for iPhone and Android!

<http://chirp.sr.bham.ac.uk/alerts>

I wish I could tell you more!

Papers coming in April 2020

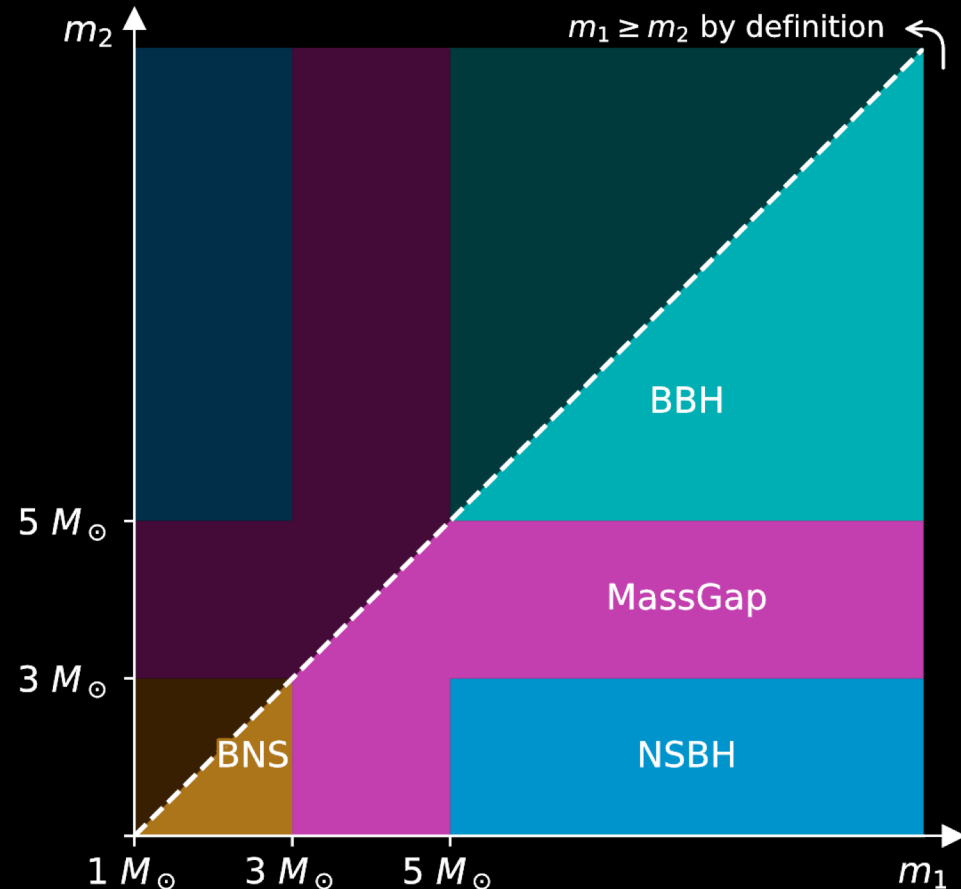

Binary Neutron Stars

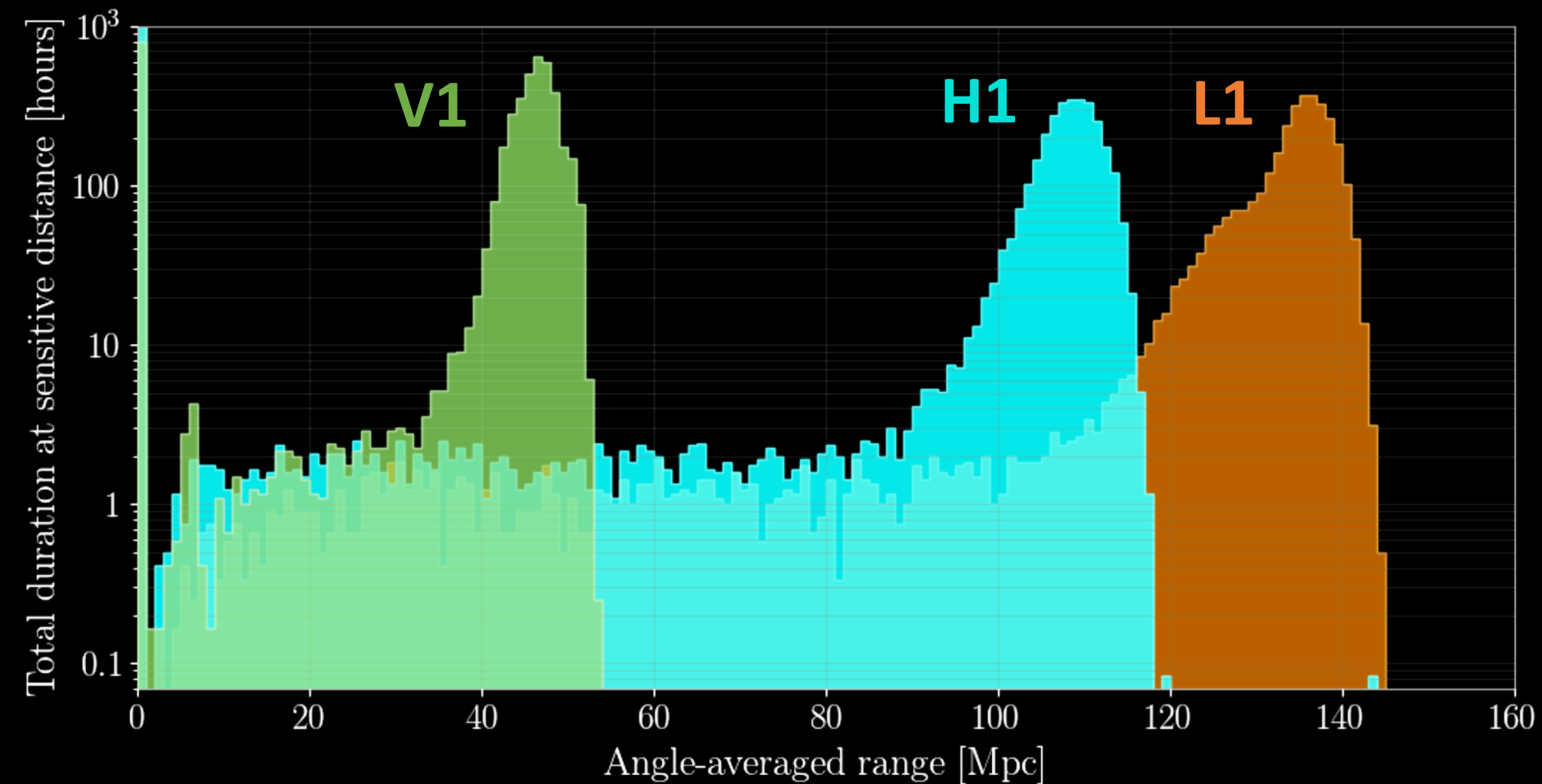

What is a point absorber?

- Localized small ($\sim 100\mu\text{m}$),
- highly absorbing ($> 1\text{E}4$ ppm)
- on test mass HR surface

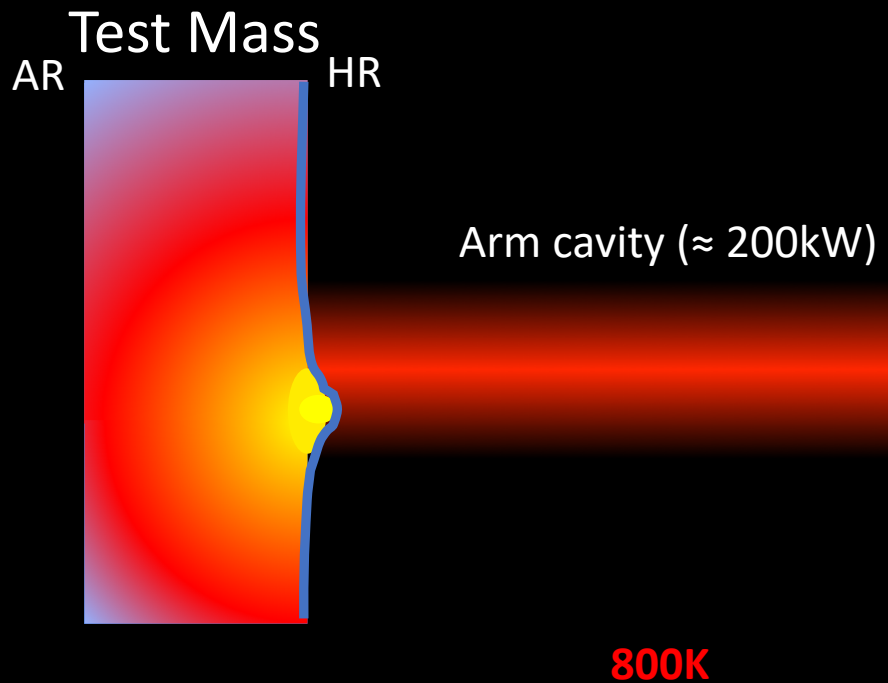

Resulting thermal lens/surface deformation

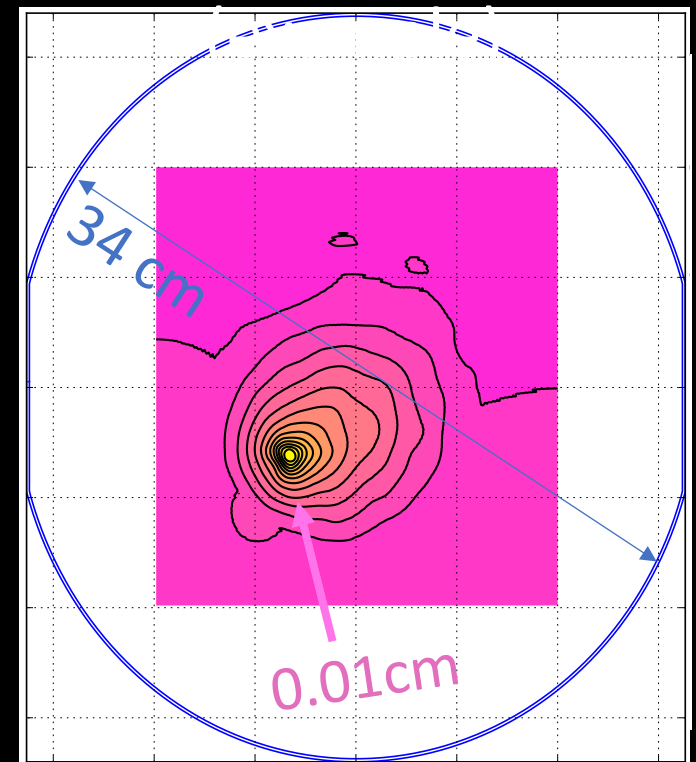

Absorber: 155 μm across bright center

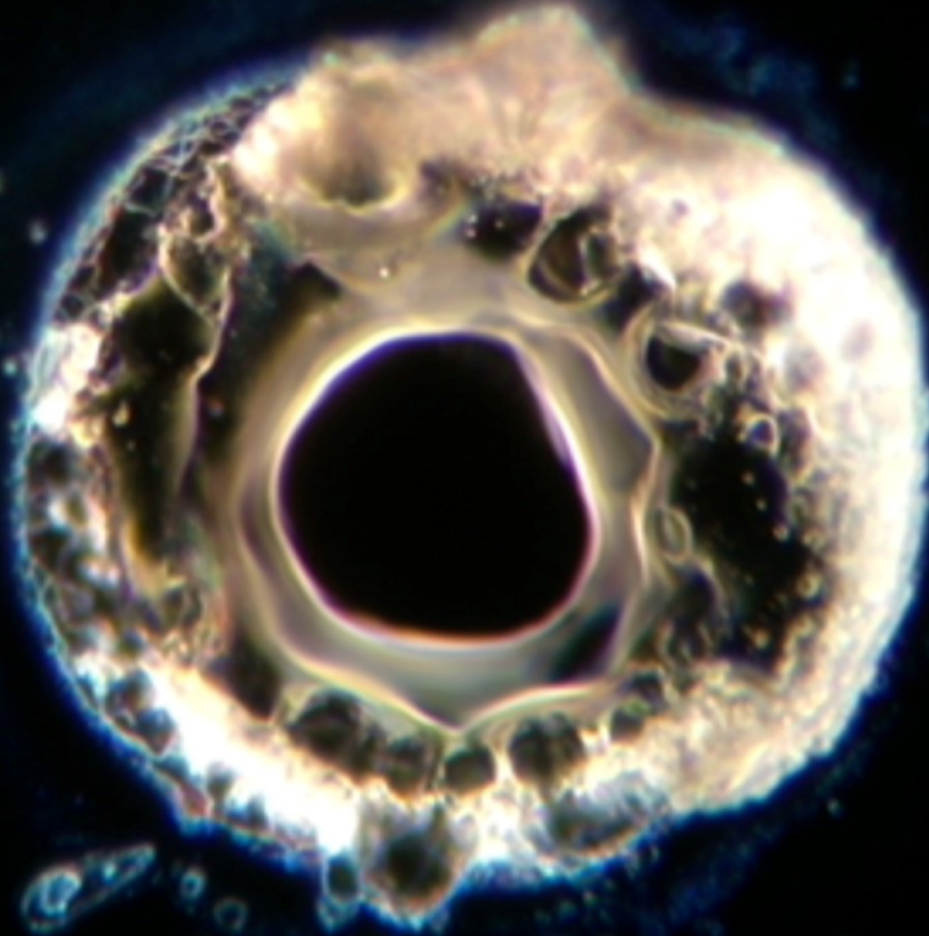

Forensics on one of H1's Input Test Mass; replaced between O2 and O3

Summary Test Masses at the end of O3a

L1

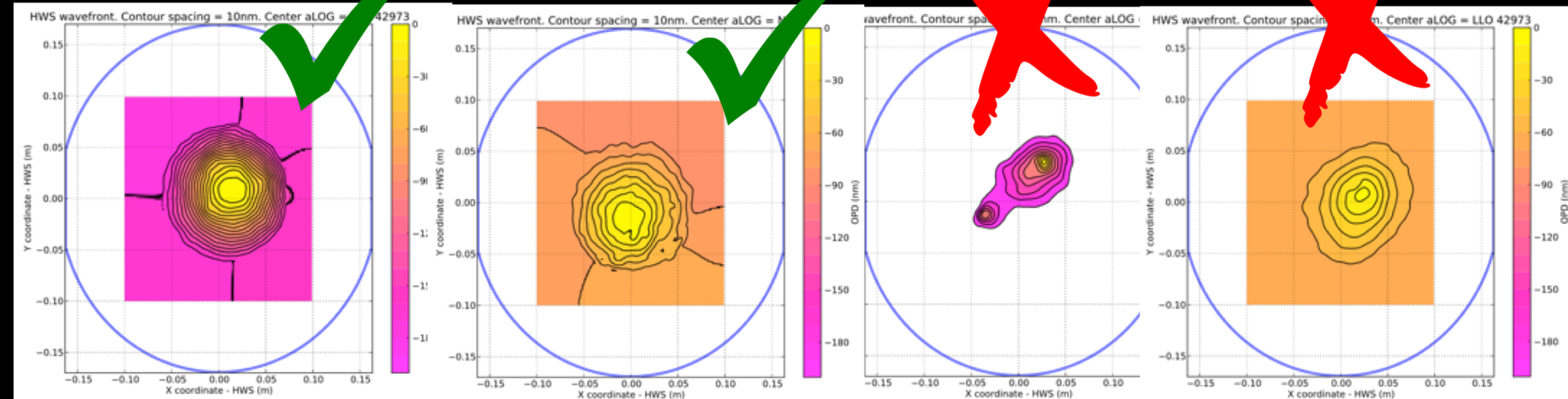

H1

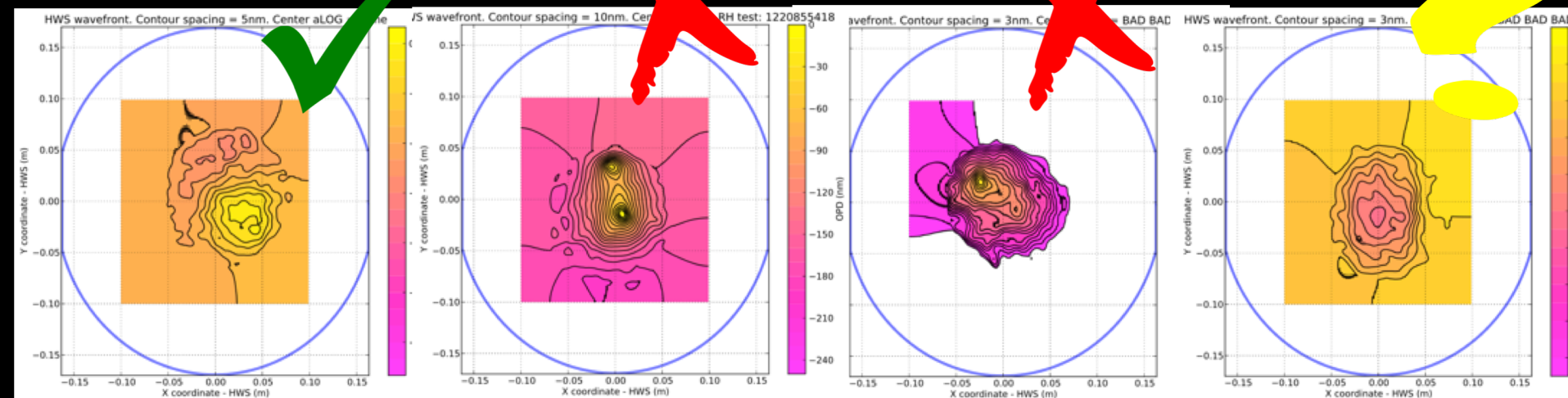

O3 Commissioning Break

Oct 2019 – Nov 2019

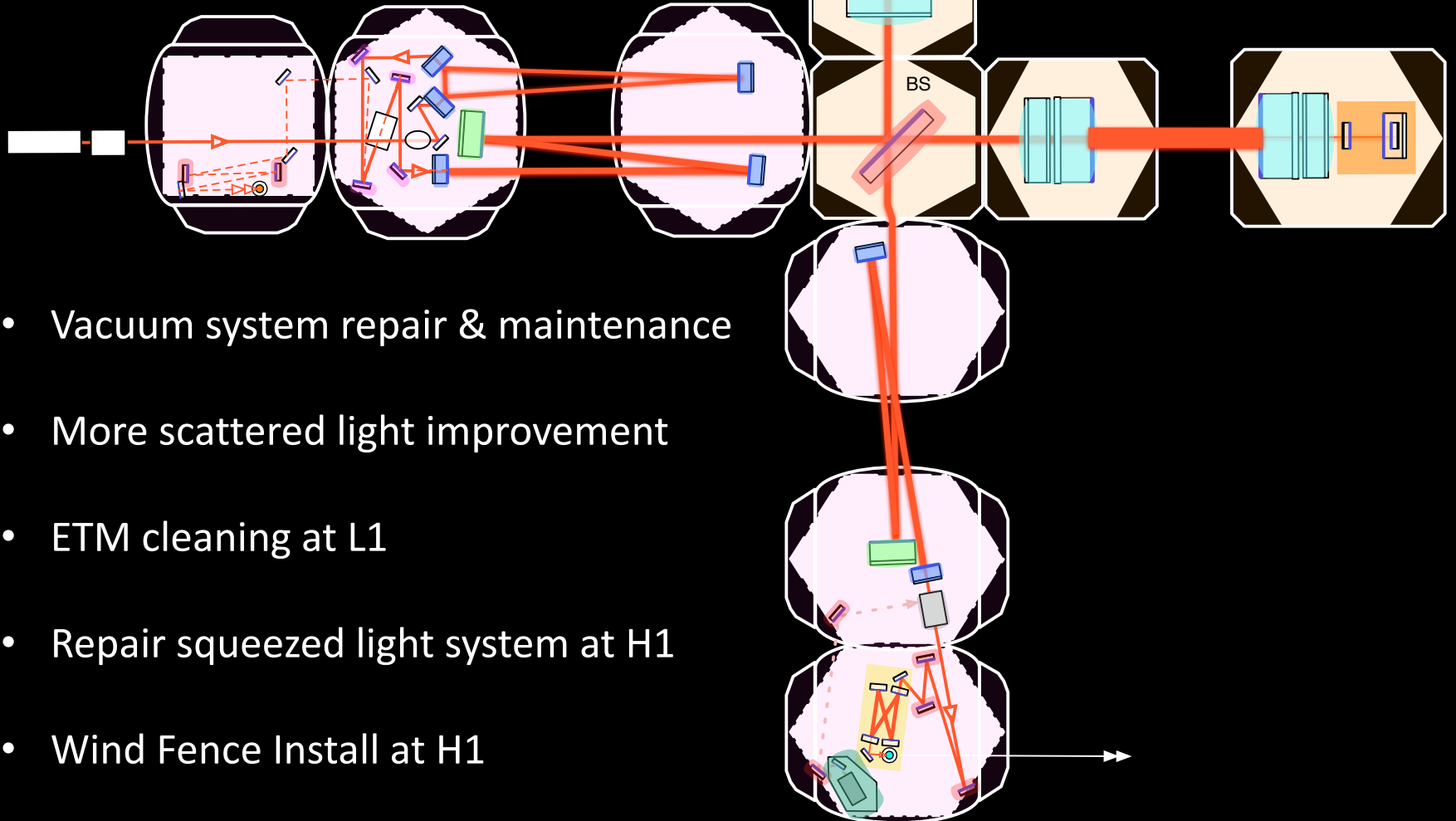

- Vacuum system repair & maintenance
- More scattered light improvement
- ETM cleaning at L1
- Repair squeezed light system at H1
- Wind Fence Install at H1

O3 Break, L1: New Shrouds

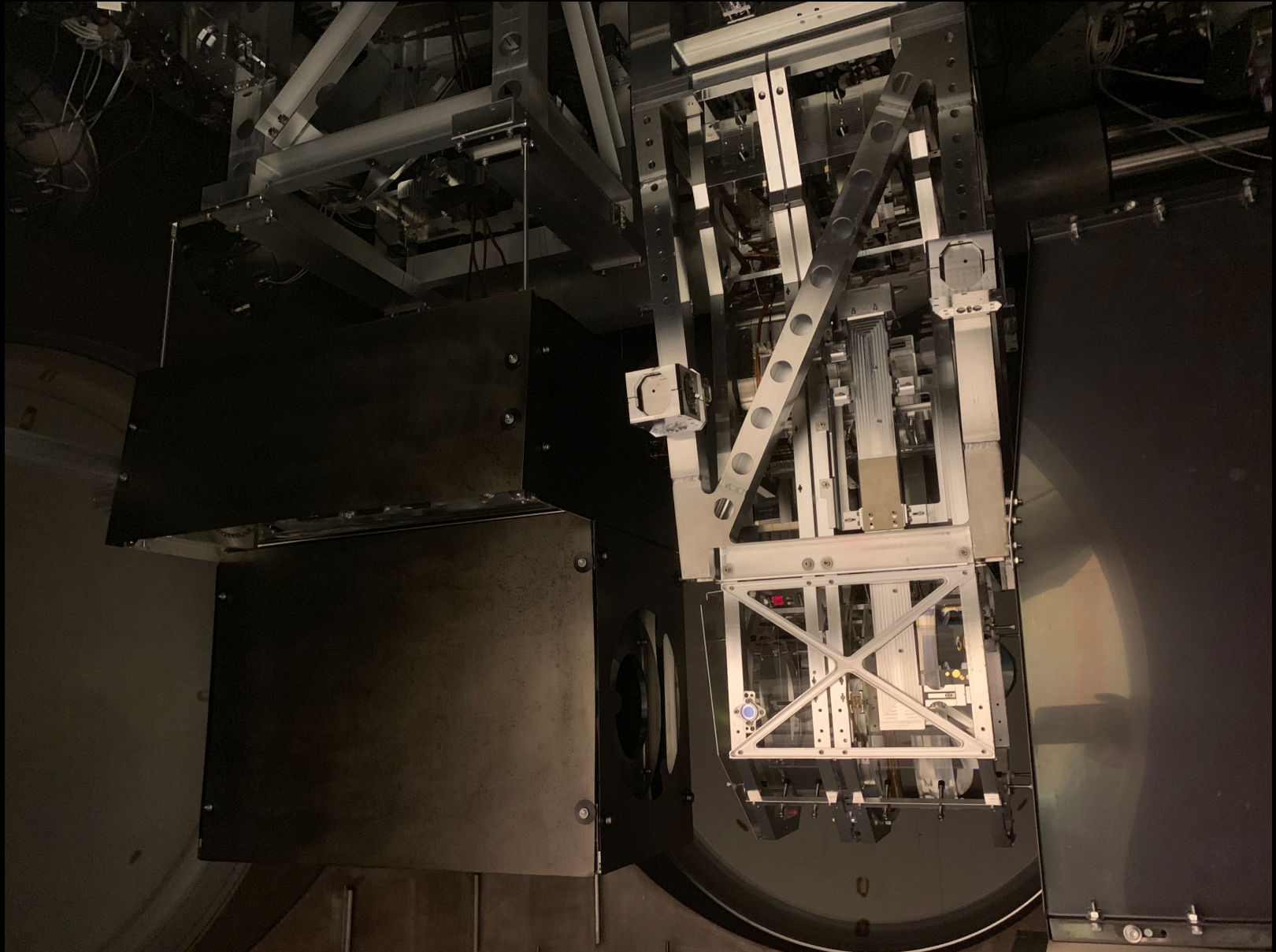

O3 Break, H1: Wind Fence



Nov 13th Picture of End-X
(Installation not yet finished!)

What we're already thinking about...

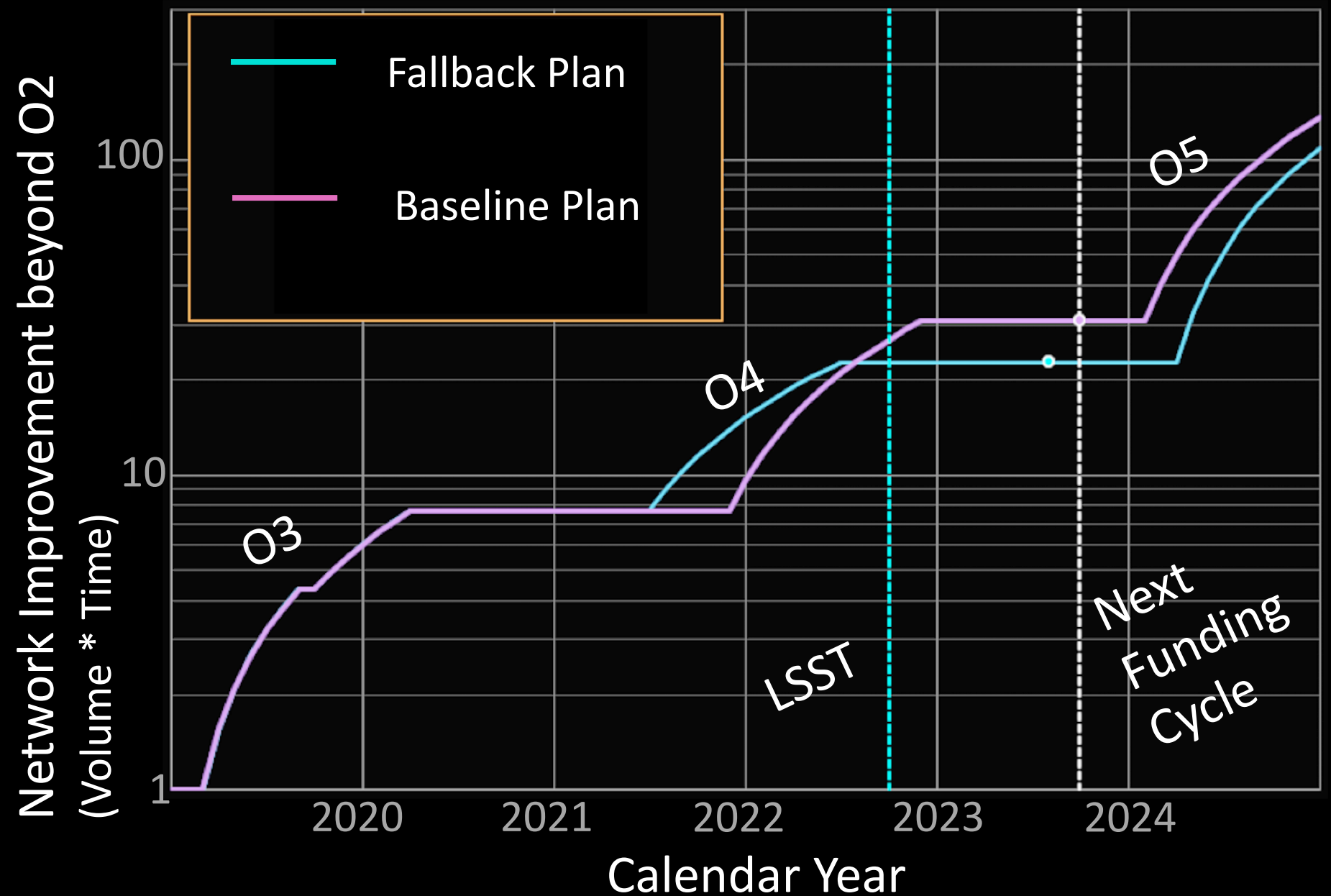

Conclusions

- O3 is already a wild success, tripling the number of detections
- The detectors are better, but there's still plenty to do
- O3 has resumed (2 events already in 2 weeks!)
- The detectors are already thinking about what they can do next!